

Ecological site R009XY032ID Riparian DECA5-CAREX

Last updated: 9/23/2020
 Accessed: 05/19/2024

General information

Provisional. A provisional ecological site description has undergone quality control and quality assurance review. It contains a working state and transition model and enough information to identify the ecological site.

Classification relationships

No data.

Associated sites

R009XY001ID	Shallow Stony Loam 16-22 PZ
R009XY002ID	North Slope Loamy 16-22 PZ
R009XY003ID	Loamy 16-22 PZ
R009XY008ID	Schist 16-22 PZ PSSPS-FEID
R009XY010ID	South Slope Schist 16-22 PZ PSSPS-POSE
R009XY017ID	Very Shallow 12-22 PZ PSSPS-POSE
R009XY031ID	Stony Riparian POBAT-ALNUS/ELYMU
R009XY033ID	Stony Bottomland SYAL/PSSP6

Similar sites

R009XY033ID	Stony Bottomland SYAL/PSSP6
-------------	-----------------------------

Table 1. Dominant plant species

Tree	Not specified
Shrub	Not specified
Herbaceous	Not specified

Physiographic features

This site occurs on gently sloping flood plains in drainageway on plateaus. Slopes are generally 0-3 percent. Elevations are 800 to 5000 feet (225-1525 meters).

Table 2. Representative physiographic features

Landforms	(1) Hill
Flooding duration	Very brief (4 to 48 hours) to brief (2 to 7 days)
Flooding frequency	Occasional to frequent
Ponding duration	Very brief (4 to 48 hours) to brief (2 to 7 days)

Ponding frequency	Rare to occasional
Elevation	244–1,524 m
Slope	0–3%
Ponding depth	5–15 cm
Water table depth	15–76 cm
Aspect	Aspect is not a significant factor

Climatic features

The elevation of MLRA 9 ranges from 2000 to 4000 feet with an average elevation of 3000 feet. Elevation along major streams averages only 650 feet above sea level. Average annual precipitation ranges from 20 to 25 inches with an average of 23 based on 9 long term climate stations located throughout the MLRA. Summers are relatively dry while precipitation is evenly distributed between fall, winter, and spring. The maximum average annual temperature is 58 degrees Fahrenheit while the average minimum temperature is 35 degrees F. The average annual temperature is 46.8 degrees F. The frost free period ranges from 107 to 134 days and the freeze free period ranges from 143 to 173 days.

Table 3. Representative climatic features

Frost-free period (average)	134 days
Freeze-free period (average)	173 days
Precipitation total (average)	660 mm

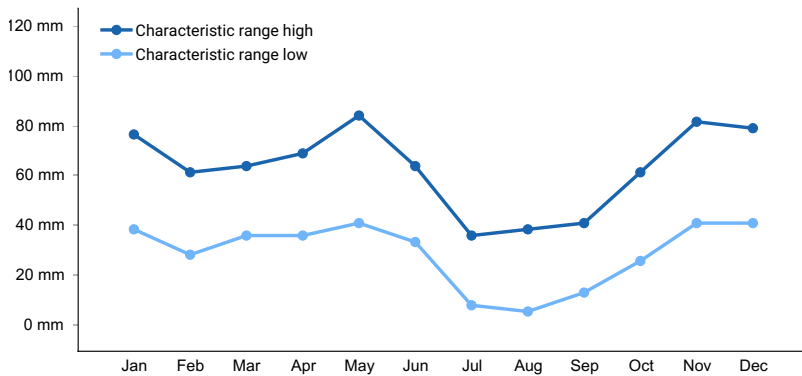

Figure 1. Monthly precipitation range

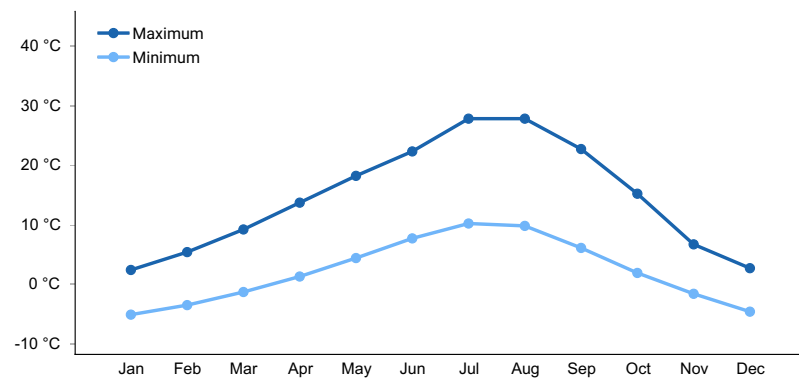

Figure 2. Monthly average minimum and maximum temperature

Influencing water features

This site is dependent on a water table above 30 inches. Some of the plants are dependent on poorly drained and non-aerated soils and others are dependent on aerated water in the profile.

Wetland Description: System Subsystem Class Sub-class
 Palustrine NA Forested Wetland
 Stream Type: Intermittent or perennial

Soil features

The soils in this site are usually somewhat poorly drained and have moderate to rapid permeability. They are associated with water courses. Soil depth varies from 40 inches to over 60 inches. The surface textures are mostly silt loams. Subsoils can be mixed gravelly and sandy alluvium. The soils usually have very little development. These soils are commonly flooded for short periods in the spring. They commonly have deposition of sediments during the floods. They are moist throughout the growing season. Plant growth depends more on the presence of the fluctuating water table and temperature than the moisture holding capacity of the soil.

The soils on this site typically have silt loam surface layers influenced by volcanic ash accumulations. They are moderately acid to neutral in reaction. These soils are associated with water courses and susceptible to gully formation which intercepts normal overflow patterns and results in site degradation. The soils are typically somewhat poorly drained and have a water table near the surface early in the spring. Runoff is low to very high, permeability is moderate to very slow and available water capacity is low to moderate. They have an aquic moisture regime and frigid temperature regime.

Soil Series Correlated to this Ecological Site.

Tombeal Aquolls
 Westlake Latchco
 Wilkins

Table 4. Representative soil features

Surface texture	(1) Ashy silt loam (2) Silty clay loam
Drainage class	Somewhat poorly drained to poorly drained
Permeability class	Moderately slow to very slow
Soil depth	102–152 cm
Surface fragment cover <=3"	0–8%
Surface fragment cover >3"	0%
Available water capacity (0-101.6cm)	14.99–20.57 cm
Calcium carbonate equivalent (0-101.6cm)	0%
Electrical conductivity (0-101.6cm)	0 mmhos/cm
Sodium adsorption ratio (0-101.6cm)	0
Soil reaction (1:1 water) (0-101.6cm)	5.6–7.3
Subsurface fragment volume <=3" (Depth not specified)	0–25%
Subsurface fragment volume >3" (Depth not specified)	0–12%

Ecological dynamics

This site is written broadly due to the variation in soils, moisture availability, aerated or non-aerated soil, and depth to the water table. This is a complex of sites. The dominant visual aspect of this riparian zone is shrubs with open

areas of grass and grass-like plants. This riparian zone commonly occurs in complex with dry meadow and meadow ecological sites. Composition by weight is approximately 40 to 60 percent grass, 15 to 25 percent forbs, and 25-35 percent shrubs.

During the last few thousand years, this site (zone) has evolved in a semi-arid climate characterized by dry summers and cold, wet winters. The site has evolved on flood plains that have occasional to frequent and brief to very brief flooding. This flooding scours some areas and deposits sediment in others. This disturbance is necessary to provide exposed moist mineral soil with full sunlight to germinate seedlings of willows and other species. Depositional areas can also bury parts of limbs and twigs to start new plants. Scouring can expose the roots of existing shrubs and this will cause them to sprout. A water table above 30 inches of depth is necessary to provide season long moisture for the growth of shrub species. Herbivory has historically occurred on this site at low levels of utilization. Herbivores include mule deer, white-tailed deer, and Rocky Mountain elk.

Fire has played a role in maintaining the plant community by also providing bare mineral soil with full sunlight to germinate willow species. Fire can cause shrub sprouting to provide regeneration. The fire frequency on the site is dependent on the frequency of fire on adjacent range sites and moisture in the fuels on the site. The normal fire frequency is 25-100 years.

The Reference State (State 1), moves through many phases depending on the natural and man-made forces that impact the community over time. State 1, described later, indicates some of these phases. The Reference Plant Community Phase is Phase A. The dominant shrubs are redosier dogwood, willows, black hawthorn, and common snowberry. The dominant grass species in the open areas are tufted hairgrass, sedges, rushes, bulrush, and slender wheatgrass. There are a variety of forbs that occur in minor amounts. The plant species composition of Phase A is listed later under "Reference Plant Community Phase Plant Species Composition".

The total annual production is 5000 pounds per acre (5600 kilograms per hectare) in a normal year. Production in a favorable year is 6000 pounds per acre (6720 kilograms per hectare). Unfavorable year production is about 4000 pounds per acre (4480 kilograms per hectare). Structurally, perennial cool season grasses and grass-like species are dominant followed by shrubs being greater than perennial forbs.

The riparian site (zone) is suited for livestock grazing in late spring, summer, and fall. This site is usually heavily used by livestock, particularly in the summer. Prescribed grazing must be planned to avoid site degradation. Special management should be used to protect the adjacent water courses and the associated values. This is an important site for wildlife for cover and food. If the site is associated with perennial streams, a fisheries resource could also be present. The site has high value for recreation such as camping and picnicking. Hunting opportunities are good where the site is isolated from human activity. Degradation of the site can occur with high recreational use, improper grazing management, and down cutting of the stream course or upper watershed conditions that alter the flood frequency or duration.

Impacts on the Plant Community:

Influence of fire:

This site can burn from wildfire. Burning usually occurs as a result of fire spreading from an adjacent range site when the fuel moisture levels are low on this site. Since the plant community on this site is strongly influenced by a water table which allows deep-rooted plants to grow throughout most of the summer, the fuels are often not dry enough to burn. The fire frequency is usually longer than adjacent range sites. Most of this site is associated with the grasslands and the normal fire frequency is estimated at 25-100 years. A wildfire can kill most of the above ground plant material. Most of the shrubs adapted to the site are root-sprouting plants and regenerate rapidly. The herbaceous layer has significant mortality but this provides exposed mineral soil for willows and other species to establish.

Influence of improper grazing management:

Season-long grazing and/or excessive utilization can be very detrimental to this site. Fall use, year after year, will result in excessive utilization on the willow regeneration. Tufted hairgrass will be reduced in the community and

remaining plants will be in low vigor. Uncontrolled beaver populations may eliminate willows and some other shrubs. Due to improper grazing management, other grasses, forbs, and shrubs can all decline in the plant community. Sedges and rushes will initially increase, but with continued improper grazing management, will die out.

Continued improper grazing management will result in a stand of forbs and Kentucky bluegrass with reduced vigor. The site then becomes susceptible to an invasion of invasive and noxious plants. When this occurs, the ability of the community to withstand seasonal flooding is reduced and down cutting of adjacent streams can result. This down cutting will lower the water table and thereby reduces the potential of the site. This site is particularly difficult to manage because animals seek out the site for shade and it is usually adjacent to water.

Proper grazing management that addresses frequency, duration, and intensity of grazing can maintain the integrity of the plant community and the water table on which it is dependent. Upstream watershed conditions must be maintained to have normal run-off events including moderate flooding.

Weather influences:

Because of the deep soils, the influence of the water table, seasonal flooding and run-on, the production of this site changes little during wet or dry precipitation years. The overall production can be adversely influenced with prolonged drought. Prolonged drought can increase fire frequency. The overall plant composition is normally not affected when perennials have good vigor.

Below normal temperatures in the spring can have an adverse impact on total production, regardless of the run-off and flooding. An early, hard freeze can occasionally kill some plants. An early frost can stop the growth of shrubs.

Influence of Insects and disease:

Periodic disease and insect outbreaks can affect vegetation health. An outbreak of a particular insect is usually influenced by weather but no specific data for this site is available.

Influence of noxious and invasive plants:

Annual and perennial invasive species can compete with desirable plants for moisture and nutrients. The result is reduced production and change in composition of the understory. There are several noxious or invasive plants that are adapted to this site.

Influence of wildlife:

This site is important for many species of mammals and birds for food and life cycles. Total numbers are seldom high enough to adversely affect the plant community. The site is primarily used in the late spring, summer, and fall by big game. Many birds use the site for food, nesting, or brood rearing in the late spring, summer, and fall.

Watershed:

The largest threat to degradation of this site is the lowering of the water table and changes in flooding characteristics either from incised channels or upstream conditions. Off-site conditions can affect the gradient of adjacent stream channels that can affect the water table. If the perennial grass, sedge, and shrub cover is depleted, down cutting can be accelerated within the site. High run-off events from the adjacent uplands can severely damage or change the normal stream channel on the site. As the water table is lowered, productive potential is lost. Eventually the water table is below the root zone of the adapted perennial grasses, shrubs, and trees. These are ultimately replaced by perennial forbs and shallow rooted grasses. Extreme down cutting and lowering of the water table can move the site across the threshold to a new, less productive site. Severe down-cutting can result in a plant community that resembles an upland site. Reducing the frequency of flooding can adversely affect the regeneration of willows, leading to a decadent overstory with no replacements.

Plant Community and Sequence:

Transition pathways between common vegetation states and phases:

State 1.

Phase A to B. Develops with much reduced flooding frequency.

Phase A to C. Develops with improper grazing management.

Phase A to D. Develops with wildfire.

Phase A to E. Develops with no fire and reduced flooding frequency.

Phase A to F. Develops with an uncontrolled beaver populations.

Phase B to A. This will occur with normal flooding frequency returning and prescribed grazing.

Phase C to A. This results from prescribed grazing.

Phase D to A. Results from no recent fires and prescribed grazing.

Phase E to A. This will occur with prescribed burning and prescribed grazing.

Phase F to A. Results from controlling the beaver population and prescribed grazing.

State 1 to State 2. This results from a deeply incised channel that reduces the water table and significantly reduces the flood frequency. The flood frequency can also be reduced from significant changes in the upper watershed that significantly changes runoff events, such as early seral plant communities, in-stream water diversions, and prolonged drought. Improper grazing management has continued. Uncontrolled beaver populations can take out all willows and some understory plants. Improper grazing management can cause down cutting which results in a lowered water table. There is reduced surface soil scouring and sediment deposition. The state is similar to early seral plant communities of Loamy Bottom ecological site. The site has crossed the threshold. This state cannot be returned to State 1 without raising the water table and restoring flood frequency. This might be done over time using structures or bio-engineering practices, but the plant community may take many years to approach the plant community in State 1.

Practice Limitations:

Use of equipment is usually not feasible for seeding. Hand seeding or aerial seeding can be considered following a fire. Brush management is not recommended. The brush has high value for stream bank stabilization and channel protection. Special management practices need to be used to protect this site from deterioration

State and transition model

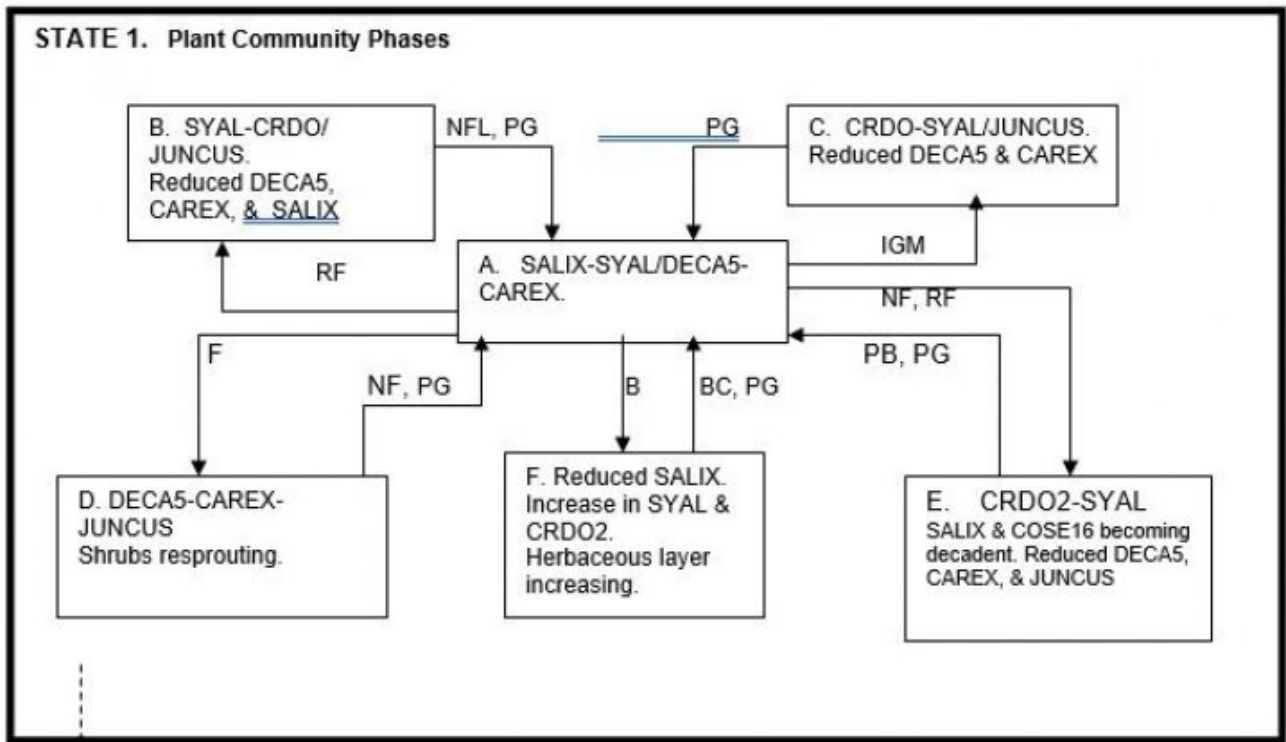

Deeply Incised channel with little or no flooding occurring and Water table lowered below 5 ft. Caused by continued IGM, Upper watershed conditions or uncontrolled beaver populations.

STATE 2. Dead shrubs and invasive species in the understory. No regeneration of SALIX.

PLANT LEGEND STATES 1 & 2

POBAT - Black Cottonwood
 SALIX - Willow
 DECA5 - Tufted hairgrass
 CAREX - Sedges
 JUNCUS- Rushes
 CRDO - Black hawthorn
 SYAL - Common snowberry
 COSE16- Redosier Dogwood

LEGEND

IGM- Improper grazing management
 PG- Prescribed grazing
 RF- Reduced flooding frequency
 NFL- Normal flooding frequency
 F - Fire
 NF- No Fire
 B - Uncontrolled beaver populations
 BC - Controlled beaver populations
 PB - Prescribed burning

———— Threshold
 —————> Community pathway (within states)
 - - - - - Reversible transition
 —————> Irreversible transition

**State 1
State 1 Phase A**

**Community 1.1
State 1 Phase A**

State1, Phase A. Reference Plant Community Phase. This plant community is dominated by a mixed age stand of willows and other shrubs. Other shrubs include various amounts of black hawthorn, redosier dogwood, and common snowberry. The herbaceous layer is dominated by tufted hairgrass and sedges. There are a wide variety of other grasses and forbs with none being dominate. The variety of shrubs, grasses, and forbs is due to the variability of soil textures and depths due to flooding deposition and/ or scouring. Flooding is frequent and the duration can be brief to prolonged. Fire can occur when adjacent sites burn and the normal fire frequency is estimated at 25-100 years.

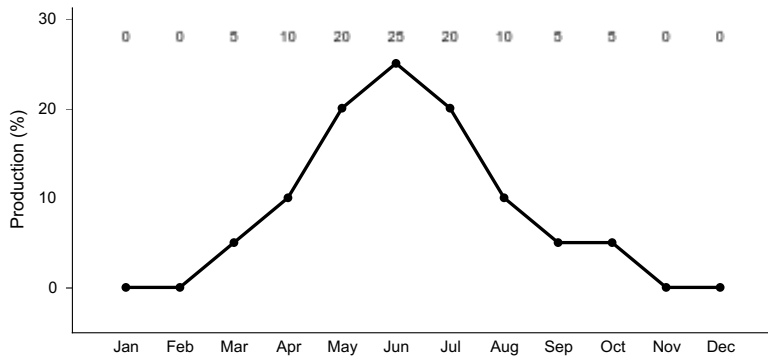

Figure 3. Plant community growth curve (percent production by month). ID0117, BLACK COTTONWOOD. STATE 1.

**State 2
State 1 Phase B**

**Community 2.1
State 1 Phase B**

State 1. Phase B. This plant community is dominated in the overstory with black hawthorn and common snowberry. Other shrubs are becoming decadent. Tufted hairgrass, sedges, and rushes have been reduced due to less moisture availability. There is little willow regeneration. This community has developed from much reduced flooding frequency due to channel down cutting, upstream water diversions or other upper watershed conditions. The water table is lower than in Phase A.

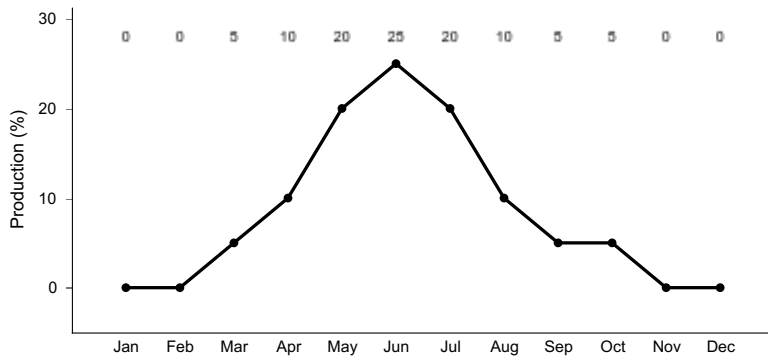

Figure 4. Plant community growth curve (percent production by month). ID0117, BLACK COTTONWOOD. STATE 1.

**State 3
State 1 Phase C**

**Community 3.1
State 1 Phase C**

State 1, Phase C. This plant community is dominated in the overstory with black hawthorn and common snowberry. Tufted hairgrass and sedges have been reduced. Rushes may have increased. The remaining shrubs and grasses have reduced vigor and shrubs may be skirted or tunneled. Production is reduced. Forbs are increasing. Some Kentucky bluegrass may have invaded the site. This community has developed with improper grazing management.

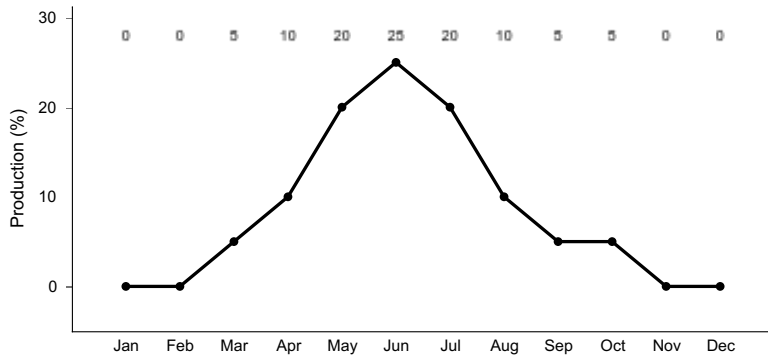

Figure 5. Plant community growth curve (percent production by month). ID0117, BLACK COTTONWOOD. STATE 1.

**State 4
State 1 Phase D**

**Community 4.1
State 1 Phase D**

State 1. Phase D. This plant community has an overstory of resprouting shrubs. Tufted hairgrass, sedges, and rushes are about the same as in Phase A but are invigorated due to the fire. This plant community has developed with a recent wildfire.

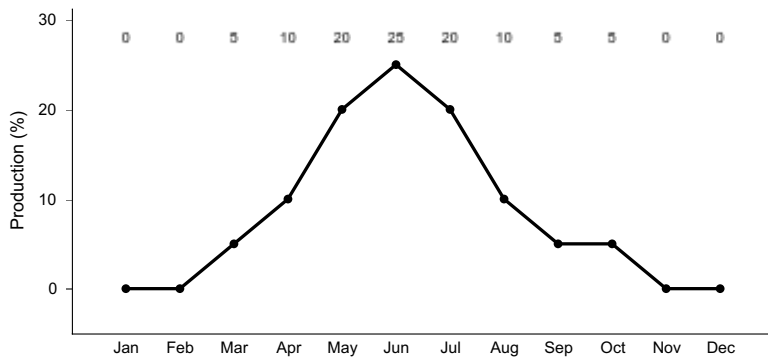

Figure 6. Plant community growth curve (percent production by month). ID0117, BLACK COTTONWOOD. STATE 1.

**State 5
State 1 Phase E**

**Community 5.1
State 1 Phase E**

State 1. Phase E. This plant community is dominated by willows and redosier dogwood that are becoming decadent. Black hawthorn and common snowberry may be increasing. Tufted hairgrass, sedges and rushes are reduced and starting to die out. There is little or no regeneration of willows. This plant community has developed with a significant reduction in flooding frequency and no fire.

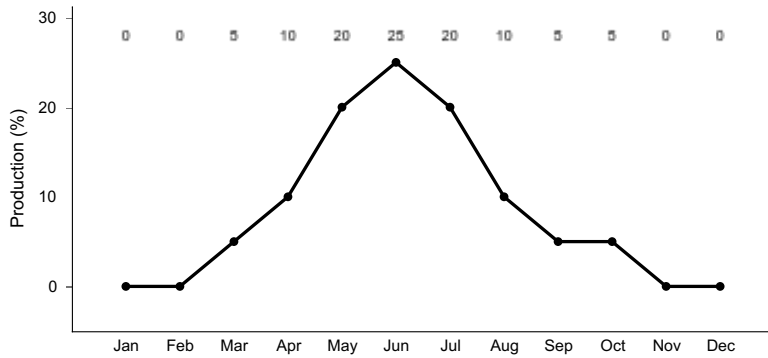

Figure 7. Plant community growth curve (percent production by month). ID0117, BLACK COTTONWOOD. STATE 1.

**State 6
State 1 Phase F**

**Community 6.1
State 1 Phase F**

State 1. Phase F. Willows have been significantly reduced. The regeneration of these plants has also been significantly reduced. Black hawthorn and common snowberry have increased. The herbaceous layer is about the same as in Phase A or may have increased slightly. This community is the result of uncontrolled beaver populations.

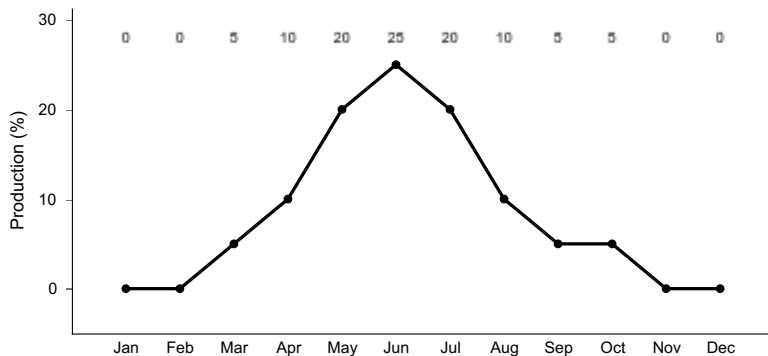

Figure 8. Plant community growth curve (percent production by month). ID0117, BLACK COTTONWOOD. STATE 1.

**State 7
State 2**

**Community 7.1
State 2**

State 2. This plant community has dead shrubs scattered throughout the site. There is no regeneration of willows and shrubs have been reduced significantly. Tufted hairgrass, sedges, and rushes and other dominate herbaceous species have been removed. Invasive and noxious plants are dominate. This plant community has developed through continued improper grazing management, lowered water table, and reduced frequency of flooding. The reduced water table and/or reduced flooding are caused by an incised channel and/or upstream conditions that have changed the flooding frequency. The community has crossed the threshold to a new state. This state cannot be returned to State 1 without raising the water table and restoring flood frequency. This might be done over time using structures or bio-engineering practices, but the plant community may take many years to approach the plant community in State 1.

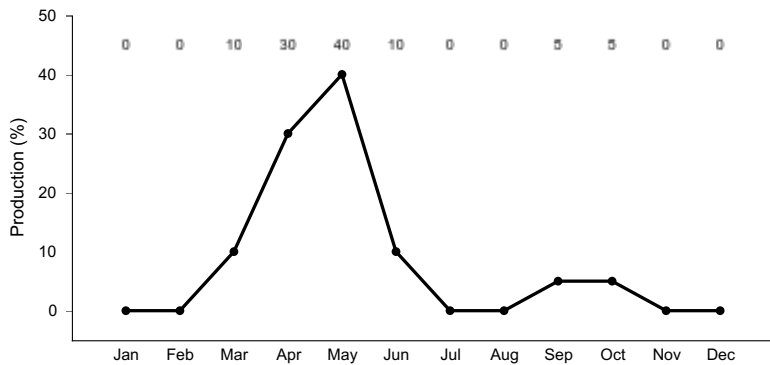

Figure 9. Plant community growth curve (percent production by month). ID0109, LOW SERAL, STATE 2.

Additional community tables

Animal community

Wildlife Interpretations.

Animal Community – Wildlife Interpretations

This riparian ecological site provides diverse habitat for wetland and upland wildlife species. The abundant forage and seasonal water attracts invertebrate and vertebrate animals to the ecological site. Important seasonal habitat is provided for over 80% of adjacent rangeland resident and migratory animals including western toad, western rattlesnake, shrews, bats, ground squirrels, beaver, mice, coyote, red fox, Swainson's hawk, northern harrier, dusky flycatcher, and yellow warbler. Large herbivore use of this ecological site includes mule deer, white-tailed deer, and elk. Native reptile and amphibians are reliant on these riparian sites throughout the year. Loss of site hydrology significantly reduces habitat value of the riparian site and adjacent ecological sites. Streams are associated with this site and provide a native fishery. Area sensitive species include Woodhouse's toad, ring-necked snake, Coeur d'Alene salamander, mountain quail, steelhead trout, sand roller, and west-slope cutthroat. The site provides critical travel corridors for all animal species. Open water is seasonal being provided by seasonal runoff, ponding, flooding, seasonal high water table, natural springs, and adjacent streams.

State 1 Phase 1.1 –Willows/ Common Snowberry/ Tufted Hairgrass/ Sedges Reference Plant Community (RPC): The RPC provides a diversity of herbaceous and woody plants used by native insect communities who assist in pollination. The insects are food for the many predator species utilizing the site. The reptile and amphibian community may include western rattlesnake, gopher snake, Woodhouse's toad, Coeur d'Alene salamander, western skink, ring-necked snake, rubber boa, terrestrial gartersnake, western toad, Columbia spotted frog, and northern leopard frog. A diverse amphibian population is a key indicator of good ecological health on this site. Loss of hydrology will limit or exclude amphibians from this ecological site. Fish species in adjacent streams can include rainbow trout, brook trout, west-slope cutthroat, steelhead trout, and sand roller. Woody vegetation adds horizontal and vertical structure for nesting and roosting sites for resident and migratory avian species. Bird species can include willow flycatcher, common yellowthroat, yellow warbler, black-capped chickadee, MacGillivray's warbler, fox sparrow, song sparrow, mountain quail, and common snipe, utilizing the plant community for breeding, resting, and nesting cover. The plant community provides year round forage for mule deer, white-tailed deer, moose, and elk. Thermal cover and young of year cover for large herbivores is provided by woody vegetation within the plant community. A small mammal population including deer mouse, western jumping mouse, beaver, and muskrat may utilize available habitat on a seasonal basis.

State 1 Phase 1.2- Common Snowberry/ Black Hawthorn/ Rushes Plant Community: This community has developed due to a much reduced flooding frequency due to channel down cutting, upstream water diversions, or other upper watershed conditions. The reduction of hydrology may reduce habitat value for amphibians identified in State 1 Phase 1.1. The reptile community may be similar to the State 1 Phase 1.1 reptile community. Quality of fishery habitat is lowered due to poor streamside plant condition, resulting in less instream food and cover. Fish species may be dominated by non-native brook trout and rainbow trout. Bird species can include black-capped chickadee, MacGillivray's warbler, fox sparrow, song sparrow, mountain quail, and common snipe, although

degradation of willow and sedge community will lower quality of habitat. Quality of thermal cover and young of year cover for ungulates is reduced due to losses of willows. Forage for mule deer, white-tailed deer, moose, and elk is reduced in the summer, fall, and winter. A small mammal population including deer mouse, montane vole, and western jumping mouse may utilize available habitat on a seasonal basis. The reduction of willows would lower the quality of habitat for beaver.

State 1 Phase 1.3- Black Hawthorn/ Common Snowberry/ Rushes Plant Community: This community has developed with improper grazing management. Insect diversity will be similar to that in State 1, Phase 1.1 but populations may be reduced due to reduced vigor and production of willows, grasses, and sedges. The amphibian community will be similar to the State 1, Phase 1.1 community. Fish species in adjacent streams can include rainbow trout, brook trout, west-slope cutthroat, steelhead trout, and sand roller. Habitat may begin to favor non-native fish species. Bird species can include willow flycatcher, common yellowthroat, yellow warbler, black-capped chickadee, MacGillivray's warbler, fox sparrow, song sparrow, mountain quail, and common snipe, utilizing the plant community for breeding, resting, and nesting cover. The plant community provides year round forage for mule deer, white-tailed deer, elk, and moose. Thermal cover and young of year cover for large herbivores is provided by woody vegetation within the plant community. Small mammal populations include deer mouse, meadow vole, montane vole, and western jumping mouse.

State 1 Phase 1.4- Tufted Hairgrass/ Sedges/ Rushes Plant Community: This plant community has developed with recent wildfire. The animal community would be represented by species similar to State 1 Phase 1.1 community but at reduced populations. The quality of habitat for species that favor grass and woody plants would decrease. Habitat quality for mountain quail and beaver may decline. Forage for large herbivores would be provided, although quality of thermal cover and young of year cover would decrease until shrubs mature. Under proper management as woody plants re-establish, you could expect the animal community to return to the diversity and populations exhibited in State 1 Phase 1.1. The loss of shrubs would fragment the historic travel corridor for small and large mammals, amphibians, reptiles, and birds.

State 1 Phase 1.5- Black Hawthorn/ Common Snowberry Plant Community: This plant community has developed with a significant reduction in flooding frequency and no fire. The animal community can be expected to be similar to the State 1, Phase 1.2 animal community.

State 1 Phase 1.6- Common Snowberry/ Black Hawthorn/ Willow Species Plant Community: This community is the result of uncontrolled beaver populations. The animal community would be represented by species similar to that in the State 1 Phase 1.1 community. The increase in shrubs (common snowberry and black hawthorn) and insects may increase habitat quality for the yellow warbler, American redstart, and a variety of flycatchers. The insect, amphibian, and fish community may be favored with the increase in flooded conditions. Large herbivore use would be similar to that in State 1, Phase 1.1 . You could expect beaver activity to create ponded sites suitable for native and non-native fish

State 2 – Dead Willows/ Invasive Plant Community: This plant community has developed through continued improper grazing management, lowered water table, and reduced frequency of flooding. Loss of historic hydrology has reduced the habitat value for many animals present in State 1. The invasive plant community would not provide pollinator habitat in all seasons. The loss of historic hydrology will limit or exclude use of the site by amphibians and many reptiles. Quality of fishery habitat is lowered due to poor streamside plant condition, resulting in poor water quality and reduced instream food and cover. Fish species may now be dominated by non-native brook trout. With continued improper grazing management the loss of vertical and horizontal structure would reduce diversity and populations of species of birds identified in State 1. With the loss of shrubs the site would be more suitable for killdeers, western meadowlark, and horned larks. Birds of prey (northern harrier and Cooper's hawk) may range throughout this area looking for prey species. With improper grazing management, forage for large herbivores would be available for a shorter duration in the summer and fall. Small mammal diversity would favor grass seed eating species (deer mouse). Predation on small mammals would increase due to poor quality cover. The loss of shrubs would fragment the historic travel corridor for small and large mammals, amphibians, reptiles, and birds.

Grazing Interpretations.

This site is suited for livestock grazing in late spring, summer, and fall. This site is usually heavily used by livestock,

particularly in the summer. Prescribed grazing must be planned to avoid degradation of the site. Special management should be used to protect the adjacent water courses and the associated values. Estimated initial stocking rate will be determined with the landowner or decision-maker. They will be based on the inventory which includes species, composition, similarity index, production, past use history, season of use, and seasonal preference. Calculations used to determine estimated initial stocking rate will be based on forage preference ratings.

Hydrological functions

The soils in this site are in hydrologic group B and C. They have moderately low to moderately high runoff potential.

Recreational uses

This site has high value for recreation such as camping, picnicking, hunting, and possibly fishing. This site provides visual diversity to the range ecosystem.

Wood products

None.

Other products

None.

Other information

Field Offices

Grangeville, ID
Craigmont, ID
Orofino, ID
Lewiston, ID
Moscow, ID
St. Maries, ID
Coeur d'Alene, ID

Inventory data references

Information presented here has been derived from NRCS clipping and other inventory data. Also, field knowledge of range-trained personnel was used. Those involved in developing this site description include:

Dave Franzen, co-owner, Intermountain Rangeland Consultants, LLC
Jacy Gibbs, co-owner, Intermountain Rangeland Consultants, LLC
Jim Cornwell, Range Management Specialist, IASCD
Brendan Brazee, State Rangeland Management Specialist, NRCS, Idaho
Bruce Knapp, Resource Soil Scientist, NRCS, Idaho
Lee Brooks, Range Management Specialist, IASCD

Other references

USDA Forest Service, Rocky Mountain Research Station. 2004. Restoring Western Ranges and Wildlands. General Technical Report RMRS-GTR-136-vols. 1-3.

USDA, NRCS. 2001. The PLANTS Database, Version 3.1 (<http://plants.usda.gov>). National Plant Data Center, Baton Rouge, LA 70874-4490 USA.

USDA, Forest Service, Fire Effects Information Database. 2004. www.fs.fed.us/database.

USDI Bureau of Land Management, US Geological Survey; USDA Natural Resources Conservation Service, Agricultural Research Service; Interpreting Indicators of Range Health. Technical Reference 1734-6; Version 4-2005.

Approval

Kendra Moseley, 9/23/2020

Rangeland health reference sheet

Interpreting Indicators of Rangeland Health is a qualitative assessment protocol used to determine ecosystem condition based on benchmark characteristics described in the Reference Sheet. A suite of 17 (or more) indicators are typically considered in an assessment. The ecological site(s) representative of an assessment location must be known prior to applying the protocol and must be verified based on soils and climate. Current plant community cannot be used to identify the ecological site.

Author(s)/participant(s)	Dave Franzen and Jacy Gibbs Intermountain Range Consultants 17700 Fargo Rd. Wilder, ID 83676
Contact for lead author	Brendan Brazee, State Rangeland Management Specialist USDA-NRCS 9173 W. Barnes Drive, Suite C, Boise, ID 83709
Date	04/20/2009
Approved by	Kendra Moseley
Approval date	
Composition (Indicators 10 and 12) based on	Annual Production

Indicators

- 1. Number and extent of rills:** rills do not occur on this site.

- 2. Presence of water flow patterns:** water flows over and through the plant community due to frequent flooding. Flows can scour the soil surface or deposit sediments. Rarely are flows detrimental to the tree components of the plant community. These plants have adapted or evolved with this occurrence. Understory species can be damaged, removed, or buried.

- 3. Number and height of erosional pedestals or terracettes:** neither occurs on this site as classically defined. Scouring can expose some roots. Tree species have evolved with this occurrence and will sprout from the roots. Deposition areas can give a hummocky surface.

- 4. Bare ground from Ecological Site Description or other studies (rock, litter, lichen, moss, plant canopy are not bare ground):** data is not available. On sites in mid-seral status bare ground may range from 2-10 percent. Immediately following a significant flood event, bare ground may be as high as 40-50 percent.

- 5. Number of gullies and erosion associated with gullies:** does not exist.

- 6. Extent of wind scoured, blowouts and/or depositional areas:** does not occur from wind. Scouring and deposition areas do occur from flooding.

7. **Amount of litter movement (describe size and distance expected to travel):** fine litter in the interspaces may move 6 feet or more or off the site due to seasonal flooding. Coarse litter can move within the site or off the site due to flooding. Some debris may hang up or be deposited in piles within the site.
-
8. **Soil surface (top few mm) resistance to erosion (stability values are averages - most sites will show a range of values):** values should range from 4 to 6 but needs to be tested.
-
9. **Soil surface structure and SOM content (include type of structure and A-horizon color and thickness):** The thickness of the A or A1 horizon ranges from 4 to 8 inches and structure of the surface layer ranges from weak fine platy to moderate very fine and fine granular. Soil organic matter (SOM) ranges from 3 to 7 percent.
-
10. **Effect of community phase composition (relative proportion of different functional groups) and spatial distribution on infiltration and runoff:** a mixed age stand of shrubs is needed to slow run-off and increase infiltration. The plant community is more dependent on moisture from the fluctuating water table than on infiltration. The water table controls rooting depth.
-
11. **Presence and thickness of compaction layer (usually none; describe soil profile features which may be mistaken for compaction on this site):** not present.
-
12. **Functional/Structural Groups (list in order of descending dominance by above-ground annual-production or live foliar cover using symbols: >>, >, = to indicate much greater than, greater than, and equal to):**
- Dominant: perennial grasses
- Sub-dominant: shrubs
- Other: forbs
- Additional:
-
13. **Amount of plant mortality and decadence (include which functional groups are expected to show mortality or decadence):** normal mortality of grass, grass-like and forbs occur with scouring and deposition from flooding. Decadence and mortality of shrubs can occur with age, disease and possible beaver activity. Disease can increase as a result of damage from flooding. Most shrubs re-sprout below or at the damaged area.
-
14. **Average percent litter cover (%) and depth (in):** additional litter cover data is needed but is expected to be ___percent to a depth of 0.5-1.5 inches at the end of the growing season, but maybe removed following flooding.
-
15. **Expected annual annual-production (this is TOTAL above-ground annual-production, not just forage annual-production):** is 5000 pounds per acre (5600 Kg/ha) in a year with normal precipitation and temperatures. Perennial grasses and sedges produce 40 to 60 percent of the total production, forbs 15 to 25 percent and shrubs 25 to 35 percent.

-
16. **Potential invasive (including noxious) species (native and non-native).** List species which **BOTH** characterize degraded states and have the potential to become a dominant or co-dominant species on the ecological site if their future establishment and growth is not actively controlled by management interventions. Species that become dominant for only one to several years (e.g., short-term response to drought or wildfire) are not invasive plants. Note that unlike other indicators, we are describing what is **NOT** expected in the reference state for the ecological site: includes whitetop, leafy spurge, dock, Canadian thistle, reed canarygrass, foxtail barley, perennial pepperweed, and teasel. Other invasive species may include meadow foxtail, redbud, and Kentucky bluegrass.
-

17. **Perennial plant reproductive capability:** all functional groups have the potential to reproduce in most years. Many of the plants reproduce vegetatively. Willows require flooding to scour the surface or provide sediment deposition to germinate seeds.
-