

## **Ecological site R010XY006ID Churning Clay 8-16 PZ ARTRX/PSSPS**

Last updated: 9/23/2020  
 Accessed: 04/12/2024

---

### General information

**Provisional.** A provisional ecological site description has undergone quality control and quality assurance review. It contains a working state and transition model and enough information to identify the ecological site.

### Classification relationships

*Artemisia vaseyana* "xericensis"/ *Agropyron spicatum* HT in "Hironaka, M., M.A. Fosberg, A. H. Winward. 1983. Sagebrush- Grass Habitat Types of Southern Idaho. University of Idaho. Moscow, Idaho. Bulletin Number 35".

### Associated sites

R010XY001ID	<b>North Slope Loamy 12-16 PZ FEID-PSSPS</b>
R010XY007ID	<b>Loamy 12-16 PZ</b>
R010XY019ID	<b>South Slope Loamy 12-16 PZ ARTRX/PSSPS</b>

### Similar sites

R010XY007ID	<b>Loamy 12-16 PZ</b>
-------------	-----------------------

**Table 1. Dominant plant species**

Tree	Not specified
Shrub	Not specified
Herbaceous	Not specified

### Physiographic features

This site occurs on nearly level to very steep slopes on all aspects, with the dominant aspect being south. Slopes usually range from 2 to 20 percent. Elevation ranges from 2000 to 3000 feet (600-900 m).

**Table 2. Representative physiographic features**

Landforms	(1) Hill (2) Landslide (3) Lava plain
Flooding frequency	None
Ponding frequency	None
Elevation	2,000–3,000 ft
Slope	2–60%
Aspect	SE, S, SW

### Climatic features

The elevation of MLRA 10 ranges from 1791 feet to 9236 feet, with a mean of 4602 feet. Overall, elevation increases from west to east. However, average annual precipitation decreases from west to east, ranging from 16.59 inches to 22.17 inches, with a mean of 19.56 inches, based on 7 long term climate stations throughout the MLRA. In general, precipitation peaks in December and January, with a steady decline to a low in July and August, then a steep increase during the autumn months. Most of the winter precipitation falls as snow, and maximum annual snowfalls of up to 82 inches have been recorded.

There is considerable variation in temperature throughout the year. Temperatures as low as -52° Fahrenheit and as high as 117° Fahrenheit are on record. Some areas have recorded the occurrence of more than 50 days with temperatures above 90° Fahrenheit. The average maximum annual temperature is 63 degrees F, while the average minimum temperature is 36.2 degrees F. The frost-free period can range from 128 to 152 days, while the freeze-free period can be from 164 to 189 days.

Both the average morning and average afternoon relative humidity values are lowest in July and August, and are below the national average. The number of clear, sunny days peaks during this same period, and is higher than the national average. During the Spring and Summer months high-intensity convective thunderstorms are not unusual.

**Table 3. Representative climatic features**

Frost-free period (average)	152 days
Freeze-free period (average)	189 days
Precipitation total (average)	22 in

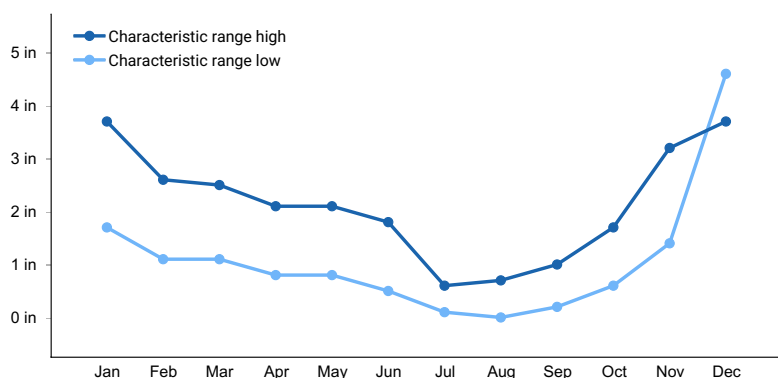

**Figure 1. Monthly precipitation range**

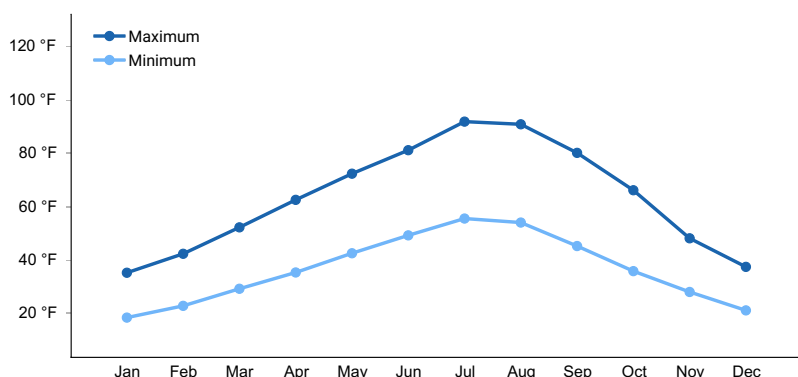

**Figure 2. Monthly average minimum and maximum temperature**

## Influencing water features

This site is not influenced by adjacent wetlands, streams or run on.

## Soil features

The soils are moderately deep to deep vertisols. The soils are easily distinguished by a granular surface appearance (when dry) or by large cracks which reach at least 18 inches into the profile. The soils are well drained, with very slow permeability or impermeable. Runoff is medium to very high. Available water holding capacity (AWC)

is low to moderate. The erosion hazard is slight to severe. The soil texture is clay with high shrink-swell capacity. Infiltration and internal water movement is slow to very slow. These soils are characterized by a xeric soil moisture regime. Soil temperature regime is mesic.

**Table 4. Representative soil features**

Surface texture	(1) Extremely stony clay loam (2) Very stony clay (3) Silty clay loam
Drainage class	Well drained
Permeability class	Very slow
Soil depth	20–60 in
Surface fragment cover <=3"	0–14%
Surface fragment cover >3"	0–65%
Available water capacity (0-40in)	3.3–7.2 in
Electrical conductivity (0-40in)	0–2 mmhos/cm
Sodium adsorption ratio (0-40in)	0–5
Soil reaction (1:1 water) (0-40in)	6.1–8.4
Subsurface fragment volume <=3" (Depth not specified)	0–14%
Subsurface fragment volume >3" (Depth not specified)	0–14%

## Ecological dynamics

The dominant visual aspect is foothills sagebrush, bluebunch wheatgrass and Sandberg bluegrass. Composition by weight is approximately 40-50% grasses, 20-30% forbs and 20-30% shrubs.

In the last few thousand years, this site has evolved in a semi-arid climate characterized by dry summers and cold, wet winters. Herbivory has historically occurred on this site at low levels of utilization. Herbivores include mule deer, lagomorphs and small rodents.

Fire has historically occurred on the site at intervals of 50-70 years. The Reference Plant Community Phase is dominated by bluebunch wheatgrass and Sandberg bluegrass in the understory and foothills sagebrush in the overstory. Subdominant species include bottlebrush squirreltail, Hooker's balsamroot, tapertip hawksbeard and biscuitroot. Total annual production is 500 pounds per acre (560 kilograms per hectare) in a normal year. Production in a favorable year is 700 pounds per acre (784 kilograms per hectare). Production in an unfavorable year is 400 pounds per acre (448 kilograms per hectare). Structurally, cool season deep-rooted perennial bunchgrasses are very dominant, followed by tall shrubs being co-dominant with perennial forbs while shallow rooted bunchgrasses are subdominant.

The Reference State (State 1), moves through many phases depending on the natural and man-made forces that impact the community over time. State 1, described later, indicates some of these phases. The Reference Plant Community Phase is Phase A. The plant species composition of Phase A is listed later under "Reference Plant Community Phase Plant Species Composition".

Impacts on the Plant Community:

#### Influence of fire:

In the absence of normal fire frequency, foothill sagebrush can gradually increase on the site. Grasses and forbs decrease as shrubs increase. With the continued absence of fire, foothill sagebrush can displace most of the primary understory species.

When fires become more frequent than historic levels (50-70 years), foothills sagebrush is reduced significantly. Medusahead is likely to invade following fire. Rabbitbrush can increase slightly. With continued short fire frequency, foothills sagebrush can be completely eliminated along with many of the desirable understory species such as bluebunch wheatgrass. These species may be replaced by a variety of annual and perennial forbs including noxious and invasive plants. These fine fuels will increase the fire frequency.

#### Influence of improper grazing management:

Season-long grazing, excessive utilization, and grazing when the soils are wet can be very detrimental to this site. This type of management leads to reduced vigor of the bunchgrasses. With reduced vigor, recruitment of these species declines. As these species decline, the plant community becomes susceptible to increase in foothills sagebrush and noxious and invasive plants.

Continued improper grazing management influences fire frequency by increasing fine fuels. If cheatgrass and/or medusahead increase due to improper grazing management and they become co-dominant with Sandberg bluegrass and other annuals, fires become more frequent.

Proper grazing management that addresses frequency, duration, and intensity of grazing can also keep fine fuels from developing, thereby reducing fire frequency. This can lead to gradual increases in foothills sagebrush. A planned grazing system can be developed to intentionally accumulate fine fuels in preparation for a prescribed burn. Any brush management should be carefully planned, as a reduction in shrubs without a suitable understory of perennial bunchgrasses can increase cheatgrass and medusahead which will lead to more frequent fire intervals.

#### Weather influences:

Above normal precipitation in March, April and May can dramatically increase total annual production of the plant community. These weather patterns can also increase viable seed production of desirable species to provide for recruitment. Likewise, below normal precipitation during these spring months can significantly reduce total annual production and be detrimental to viable seed production. Overall plant composition is normally not affected when perennials have good vigor.

Below normal temperatures in the spring can have an adverse impact on total production regardless of the precipitation. An early, hard freeze can occasionally kill some plants.

Prolonged drought adversely affects this plant community in several ways. Vigor, recruitment, and production are usually reduced. Mortality can occur. Prolonged drought can lead to a reduction in fire frequency.

#### Influence of Insects and disease:

Insect and disease outbreaks can affect vegetation health, but no specific data is available for this site. Grasshopper and Mormon cricket outbreaks occur sporadically. Since the outbreak usually occurs for only one year, their impact causes little mortality on the vegetation.

#### Influence of noxious and invasive plants:

Medusahead can be a very invasive plant on this site. This species and other invasive plants add to the fine-fuel component and lead to increased fire frequency. Perennial and annual invasive species compete with desirable plants for moisture and nutrients. The result is reduced production and change in composition of the understory.

#### Influence of wildlife:

Big game, primarily mule deer make use of this site in the spring, summer, fall, and winter. Their numbers are seldom high enough to adversely affect the plant community. Pronghorn antelope use this site very little due to the height of foothills sagebrush.

Watershed:

Decreased infiltration and increased runoff occur with an increase in foothills sagebrush. Desired understory species can be reduced. This composition change can affect nutrient and water cycles. Increased runoff also causes sheet and rill erosion. Abnormally short fire frequency also gives the same results, but to a lesser degree. The long term effect is a transition to a different state.

Plant Community and Sequence:

Transition pathways between common vegetation states and phases:

State 1.

Phase A to B. Develops with improper grazing management and no fire.

Phase A to C. Develops with fire.

Phase B to A. Develops with prescribed grazing.

Phase C to A. Develops with prescribed grazing and no fire.

State 1 Phase C to State 2. Develops through frequent fire or continued improper grazing management. This site has crossed the threshold. It is not economically feasible to move it back towards the HCPC.

State 2 to unknown site. Excessive soil loss and changes in the hydrologic cycle caused by continued improper grazing management and/or frequent fire cause this state to cross a threshold and regress to a new site with reduced potential. It is not economically feasible to move it back towards the HCPC.

Practice Limitations.

Severe limitations exist for seeding on this site, especially at the lower end of the precipitation range due to adverse soil textures and structure. Late winter to early spring seedings offer the best opportunity for successful establishment. Few limitations exist for brush management on this site.

## **State and transition model**

## STATE 1. Plant Community Phases

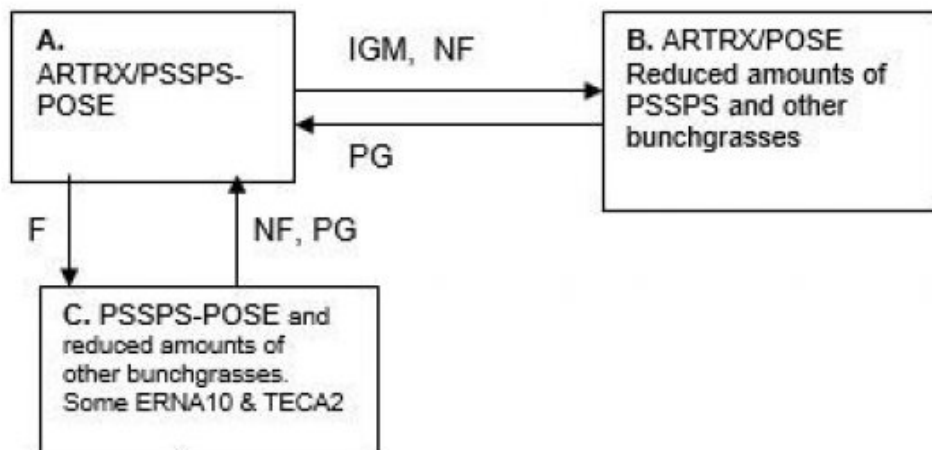

FF  
or  
IGM

STATE 2.  
POSE-TACA8-BRTE-ANNUALS

IGM and/or FF

UNKNOWN AND  
NEW SITE

### LEGEND

IGM- Improper grazing management  
PG- Prescribed grazing  
FF- Frequent fire  
NF- No fire  
F- Fire

→ Community pathway (within states)

- - - - - Reversible transition

— Threshold

⇒ Irreversible transition

### Plant Legend States 1 & 2

ARTRX - Foothills Sagebrush  
PSSPS - Bluebunch Wheatgrass  
POSE - Sandberg Bluegrass  
TACA8 - Medusahead Rye  
BRTE - Cheatgrass  
ERNA10 - Tall Gray Rabbitbrush  
TECA2 - Gray Horsebrush

## State 1

### State 1 Phase A

### Community 1.1

### State 1 Phase A

State 1, Phase A, Reference Plant Community Phase. This plant community has foothills sagebrush in the overstory

with bluebunch wheatgrass and Sandberg bluegrass dominating the understory. Bottlebrush squirreltail , Hooker's balsamroot, biscuitroot and tapertip hawksbeard are sub-dominant species. Natural fire frequency is 50-70 years.

**Table 5. Ground cover**

Tree foliar cover	0%
Shrub/vine/liana foliar cover	0%
Grass/grasslike foliar cover	0%
Forb foliar cover	0%
Non-vascular plants	0%
Biological crusts	0%
Litter	30-60%
Surface fragments >0.25" and <=3"	0%
Surface fragments >3"	0%
Bedrock	0%
Water	0%
Bare ground	0%

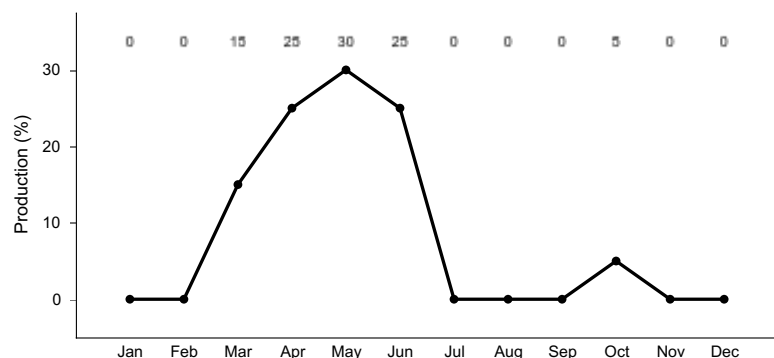

**Figure 3. Plant community growth curve (percent production by month). ID0905, D25ARTRV South. State 1.**

## State 2 State 1 Phase B

### Community 2.1 State 1 Phase B

State 1, Phase B. This plant community is dominated by foothills sagebrush with reduced amounts of bluebunch wheatgrass and Sandberg bluegrass. All deep-rooted bunchgrasses are typically in low vigor. Foothills sagebrush is increasing. This state has developed due to improper grazing management and no fire. Some medusahead and cheatgrass may have invaded the site.

**Table 6. Ground cover**

Tree foliar cover	0%
Shrub/vine/liana foliar cover	0%
Grass/grasslike foliar cover	0%
Forb foliar cover	0%
Non-vascular plants	0%
Biological crusts	0%
Litter	30-60%

Surface fragments >0.25" and <=3"	0%
Surface fragments >3"	0%
Bedrock	0%
Water	0%
Bare ground	0%

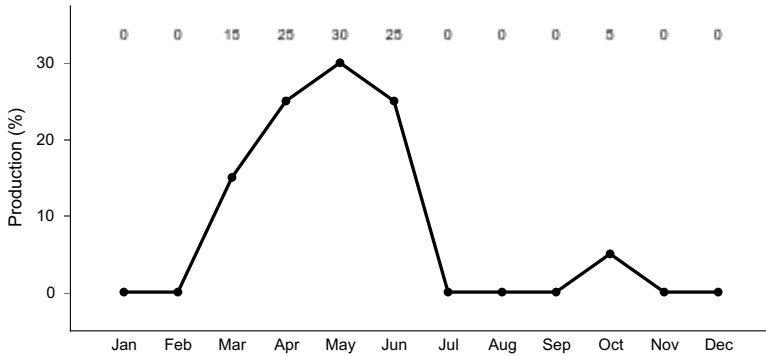

Figure 4. Plant community growth curve (percent production by month). ID0905, D25ARTRV South. State 1.

### State 3 State 1 Phase C

#### Community 3.1 State 1 Phase C

State 1, Phase C. This plant community is dominated by bluebunch wheatgrass and Sandberg bluegrass. Forbs remain about in the same proportion as Phase A. Very little foothills sagebrush is present due to wildfire, but some rabbitbrush and horsebrush are present due to sprouting. Some medusahead and cheatgrass may have invaded the site. This plant community is the result of wildfire.

Table 7. Ground cover

Tree foliar cover	0%
Shrub/vine/liana foliar cover	0%
Grass/grasslike foliar cover	0%
Forb foliar cover	0%
Non-vascular plants	0%
Biological crusts	0%
Litter	30-60%
Surface fragments >0.25" and <=3"	0%
Surface fragments >3"	0%
Bedrock	0%
Water	0%
Bare ground	0%



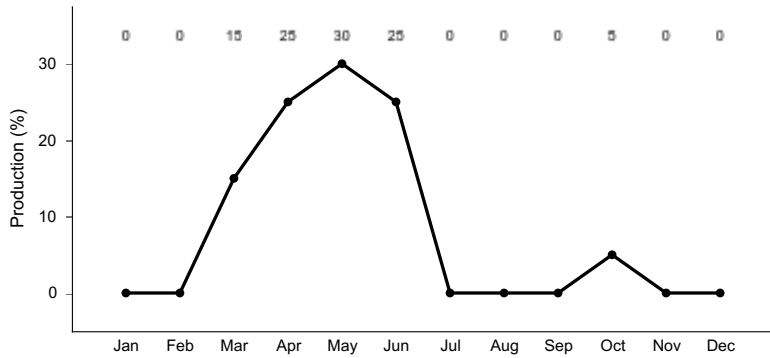

Figure 5. Plant community growth curve (percent production by month). ID0905, D25ARTRV South, State 1.

**State 4**  
**State 2**

**Community 4.1**  
**State 2**

State 2. This plant community is dominated by Sandberg bluegrass, medusahead, cheatgrass and other annuals. Root sprouting shrubs such as rabbitbrush and horsebrush can be present, dependent upon, how frequent, fire has occurred. Some soil loss has occurred. This state has developed primarily due to frequent fires but improper grazing management can accelerate the transition to the unknown site. This plant community has crossed the threshold. It is not economically feasible to move this state back towards State 1.

Table 8. Ground cover

Tree foliar cover	0%
Shrub/vine/liana foliar cover	0%
Grass/grasslike foliar cover	0%
Forb foliar cover	0%
Non-vascular plants	0%
Biological crusts	0%
Litter	30-60%
Surface fragments >0.25" and <=3"	0%
Surface fragments >3"	0%
Bedrock	0%
Water	0%
Bare ground	0%

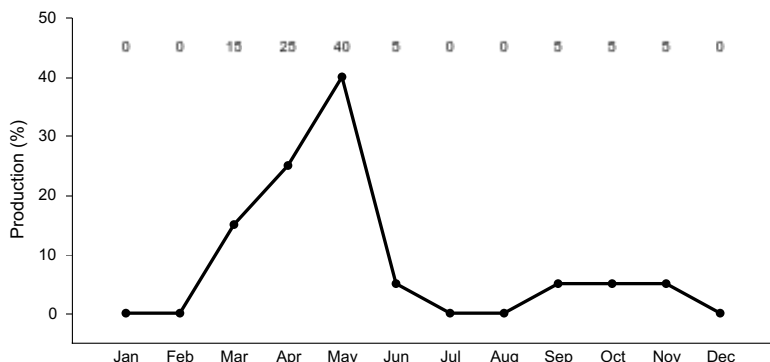

Figure 6. Plant community growth curve (percent production by month). ID0911, D25 POSE/BRTE/ANNUALS.

## State 5

## State 3

### Community 5.1

## State 3

Table 9. Ground cover

Tree foliar cover	0%
Shrub/vine/liana foliar cover	0%
Grass/grasslike foliar cover	0%
Forb foliar cover	0%
Non-vascular plants	0%
Biological crusts	0%
Litter	30-60%
Surface fragments >0.25" and <=3"	0%
Surface fragments >3"	0%
Bedrock	0%
Water	0%
Bare ground	0%

### Additional community tables

#### Animal community

Wildlife Interpretations:

#### Animal Community – Wildlife Interpretations

This rangeland ecological site provides diverse habitat for many native wildlife species. Large herbivore use of this ecological site is dominated by mule deer and to a lesser extent elk. Important seasonal habitat is provided for resident and migratory animals including western toad, sagebrush lizard, western rattlesnake, shrews, bats, jackrabbits, ground squirrels, mice, coyote, red fox, badger, sage-grouse, Ferruginous hawk, prairie falcon, horned lark and western meadowlark. Changes in the plant community composition can reduce the number and diversity of wildlife species in the area. With reduced shrub cover, shrub obligate avian species become rare including sage-grouse, brewer's sparrow and sage thrasher. Encroachment of noxious and invasive plant species (cheatgrass, Medusahead) can replace native plant species which provide critical feed, brood-rearing and nesting cover for a variety of native wildlife. The loss of herbaceous understory vegetation has a negative impact on ground nesting birds, while the loss of shrub cover negatively affects both ground and shrub nesting avians. Water features are sparse provided by seasonal streams, artificial water catchments and springs.

State 1 Phase 1.1 - Foothills Big Sagebrush/ Bluebunch Wheatgrass/ Sandberg Bluegrass Reference Plant Community (RPC): This plant community provides a diversity of grasses, forbs and shrubs used by native insect communities that assist in pollination. The reptile and amphibian community is represented by leopard lizard, short horned lizard, sagebrush lizard, western skink, western rattlesnake, western toad, boreal chorus frog and northern leopard frog. Amphibians are associated with springs and isolated water bodies adjacent to this plant community. Spring developments that capture all available water would preclude the use of these sites by amphibians. The plant community provides habitat for prey species and cover for these resident reptiles and amphibians. Shrub-steppe obligate avian species include the Brewer's sparrow, sage sparrow, sage thrasher and sage-grouse. Critical habitat (lek sites, nesting areas, winter cover and food) for sage-grouse is provided by this diverse plant community. The plant community supports the needs of large mammals (mule deer and elk) providing forage and cover on a seasonal basis. A diverse small mammal population including golden-mantled ground squirrels, chipmunks, yellow-bellied marmots, and pygmy rabbits utilize this plant community.

State 1 Phase 1.2 – Foothills Big Sagebrush/Sandberg Bluegrass/ Bottlebrush Squirreltail Plant Community: This state has developed due to improper grazing management and no fire. An increase in canopy cover of sagebrush contributes to a sparse herbaceous understory. Grasses, forbs and shrubs, are used by native insects that assist in pollination but the reduced herbaceous understory results in lower diversity and numbers of insects. The reptile community is represented by leopard lizard, short horned lizard, sagebrush lizard, western skink and western rattlesnake. Diversity and population of the reptile community would decline due to a reduced understory and associated loss of invertebrate habitat. Spring developments that capture all available water would preclude the use of these sites by amphibians. Key shrub-steppe obligate avians include Brewer's sparrow, sage sparrow, sage thrasher and sage-grouse. Reduced herbaceous understory is a key factor in limiting the use of this plant community by avian species. Critical habitat (lek sites, nesting areas, winter cover and food) for sage grouse is limited due to a less diverse herbaceous plant community. The plant community supports the needs of large mammals (mule deer and elk) providing forage and cover on a seasonal basis. A diverse small mammal population including golden-mantled ground squirrels, chipmunks, deer mouse and yellow-bellied marmots would utilize the habitat.

State 1 Phase 1.3 - Bluebunch Wheatgrass/ Sandberg Bluegrass Plant Community: This plant community is the result of fire. The plant community, dominated by herbaceous vegetation with little or no sagebrush provides less vertical structure for wildlife. Insect diversity would be reduced but a diverse native forb plant community would still support select pollinators. Reptile use including short horned lizard, sagebrush lizard and western rattlesnakes, would be limited or excluded due to the absence of sagebrush. The dominance of herbaceous vegetation with reduced sagebrush canopy cover would eliminate the use of these areas for nesting by Brewer's sparrow, sage sparrow, sage thrasher, and sage-grouse. This plant community provides limited brood- rearing habitat for sage-grouse when sagebrush cover is adjacent to the site. Sage-grouse would not use the area for wintering habitat. The dominant herbaceous vegetation improves habitat for grassland avian species (horned lark and western meadowlark). Large mammal (mule deer and elk) forage use would be seasonal and the site would offer little thermal cover and young of year cover. The populations of small mammals would be dominated by open grassland species like the Columbian ground squirrel.

State 2 – Sandberg Bluegrass/ Medusahead Rye/ Cheatgrass/ Annual Plant Community: This state has developed primarily due to frequent fires but improper grazing management can accelerate the. The loss of the native shrub and herbaceous plant community would not support a diverse insect community. Most native reptilian species are not supported with food, water or cover. This plant community does not support the habitat requirements for sage-grouse, sage thrasher, Brewer's sparrow or sage sparrow. Diversity of grassland avian species is reduced due to poor cover and food. Birds of prey including hawks and falcons may range throughout these areas looking for prey species. Large mammals may utilize the herbaceous vegetation in the early part of the year when the invasive annuals (cheatgrass) are more palatable. At other times of the year large mammals would not regularly utilize these areas due to poor food and cover conditions. The populations of small mammals would be dominated by open grassland species like the Columbian ground squirrel.

#### Grazing Interpretations:

This site is suited for early summer to fall grazing by domestic livestock. Grazing should not be allowed when soils are wet which can cause trampling damage. Some hazard exists for sheep or small calves due to large cracks which can occur under dry conditions.

Estimated initial stocking rate will be determined with the landowner or decision-maker. They will be based on the inventory which includes species, composition, similarity index, production, past use history, season of use and seasonal preference. Calculations used to determine estimated initial stocking rate will be based on forage preference ratings

#### Hydrological functions

The soils in this site are in hydrologic group D. When hydrologic conditions of the vegetation cover are good, natural erosion hazard is moderate.

## Recreational uses

This site has poor to fair values for recreation and aesthetics. The churning clay soils severely limit camping and picnic areas along with building construction.

## Wood products

None

## Other products

None

## Other information

Field Offices:

Weiser, ID

Emmett, ID

Mountain Home, ID

Meridian, ID

Cascade, ID

## Inventory data references

Information presented here has been derived from NRCS clipping and other inventory data. Also, field knowledge of range-trained personnel was used. Those involved in developing this site description include:

Dave Franzen, co-owner, Intermountain Rangeland Consultants, LLC

Jacy Gibbs, co-owner, Intermountain Rangeland Consultants, LLC

Jim Cornwell, Range Management Specialist, IASCD

Brendan Brazee, State Rangeland Management Specialist, NRCS, Idaho

Lee Brooks, Range Management Specialist, IASCD

Leah Juarros, Resource Soil Scientist, NRCS, Idaho

## Type locality

Location 1: Washington County, ID
-----------------------------------

## Other references

Hironaka, M., M.A. Fosberg, A. H. Winward. 1983. Sagebrush- Grass Habitat Types of Southern Idaho. University of Idaho. Moscow, Idaho. Bulletin Number 35

USDA Forest Service, Rocky Mountain Research Station. 2004. Restoring Western Ranges and Wildlands. General Technical Report RMRS-GTR-136-vols. 1-3.

USDA, NRCS.2001. The PLANTS Database, Version 3.1 (<http://plants.usda.gov>). National Plant Data Center, Baton Rouge, LA 70874-4490 USA

USDA, Forest Service, Fire Effects Information Database. 2004. [www.fs.fed.us/database](http://www.fs.fed.us/database).

USDI Bureau of Land Management, US Geological Survey; USDA Natural Resources Conservation Service, Agricultural Research Service; Interpreting Indicators of Rangeland Health. Technical Reference 1734-6; version 4-2005.

## Approval

Kendra Moseley, 9/23/2020

## Rangeland health reference sheet

Interpreting Indicators of Rangeland Health is a qualitative assessment protocol used to determine ecosystem

condition based on benchmark characteristics described in the Reference Sheet. A suite of 17 (or more) indicators are typically considered in an assessment. The ecological site(s) representative of an assessment location must be known prior to applying the protocol and must be verified based on soils and climate. Current plant community cannot be used to identify the ecological site.

Author(s)/participant(s)	Dave Franzen and Jacy Gibbs Intermountain Range Consultants 17700 Fargo Rd. Wilder, ID 83676
Contact for lead author	Brendan Brazee, State Rangeland Management Specialist USDA-NRCS 9173 W. Barnes Drive, Suite C, Boise, ID 83709
Date	03/24/2008
Approved by	Kendra Moseley
Approval date	
Composition (Indicators 10 and 12) based on	Annual Production

## Indicators

1. **Number and extent of rills:** Do not occur on this site due to the relatively flat slopes. If rills do develop, they are broken up by the churning action of the soil.  

---
2. **Presence of water flow patterns:** Do not occur on this site due to the relatively flat slopes. If water flow patterns do develop, they are broken up by the churning action of the soil.  

---
3. **Number and height of erosional pedestals or terracettes:** Are rare on this site. In areas of greater than 25% slopes where flow patterns and/or rills are present, a few pedestals and terracettes may be expected.  

---
4. **Bare ground from Ecological Site Description or other studies (rock, litter, lichen, moss, plant canopy are not bare ground):** Ranges from 40-60 percent.  

---
5. **Number of gullies and erosion associated with gullies:** Do not occur on this site.  

---
6. **Extent of wind scoured, blowouts and/or depositional areas:** Does not occur.  

---
7. **Amount of litter movement (describe size and distance expected to travel):** Fine litter in the interspaces may move up to 3 feet or further following a significant run-off event. Cracks in the soil surface that occur during the summer and fall trap litter. Coarse litter generally does not move.  

---
8. **Soil surface (top few mm) resistance to erosion (stability values are averages - most sites will show a range of values):** Values should range from 4 to 6 but needs to be tested.  

---

9. **Soil surface structure and SOM content (include type of structure and A-horizon color and thickness):** The A or A1 horizon is typically 1 to 6 inches thick. Structure ranges from weak thin platy to strong medium granular. Soil organic matter (SOM) ranges from 0.5 to 5 percent.
- 
10. **Effect of community phase composition (relative proportion of different functional groups) and spatial distribution on infiltration and runoff:** Bunchgrasses, especially deep-rooted perennials, slow run-off and increase infiltration. Shrubs accumulate snow in the interspaces.
- 
11. **Presence and thickness of compaction layer (usually none; describe soil profile features which may be mistaken for compaction on this site):** Does not occur.
- 
12. **Functional/Structural Groups (list in order of descending dominance by above-ground annual-production or live foliar cover using symbols: >>, >, = to indicate much greater than, greater than, and equal to):**
- Dominant: Cool season deep-rooted perennial bunchgrasses.
- Sub-dominant: Tall shrubs> perennial forbs> shallow rooted grasses.
- Other:
- Additional:
- 
13. **Amount of plant mortality and decadence (include which functional groups are expected to show mortality or decadence):** Foothills sagebrush becomes decadent in the absence of fire and ungulate grazing. Mortality of grasses and forbs occurs from the shrinking and swelling of the soil.
- 
14. **Average percent litter cover (%) and depth ( in):** Annual litter cover in the interspaces will be 5-10 percent to a depth of <0.1 inches. Under the mature shrubs litter is greater than 0.5 inches. Fine litter falls or blows into the surface cracks in the soil.
- 
15. **Expected annual annual-production (this is TOTAL above-ground annual-production, not just forage annual-production):** 500 lbs. per acre in a year with normal precipitation and temperatures. Perennial grasses produce 40-50 percent of the total, forbs 20-30 percent, and shrubs 20-30 percent.
- 
16. **Potential invasive (including noxious) species (native and non-native). List species which BOTH characterize degraded states and have the potential to become a dominant or co-dominant species on the ecological site if their future establishment and growth is not actively controlled by management interventions. Species that become dominant for only one to several years (e.g., short-term response to drought or wildfire) are not invasive plants. Note that unlike other indicators, we are describing what is NOT expected in the reference state for the ecological site:** Medusahead is the most troublesome invasive plant on this site. Other ones that may be found on the site include cheatgrass, bulbous bluegrass, rush skeletonweed, scotch thistle, spotted and diffuse knapweed.
-

17. **Perennial plant reproductive capability:** All functional groups have the potential to reproduce in normal years.

---