

Ecological site R010XY018ID Shallow South Stony 14-18 PZ PSSPS-POSE

Last updated: 9/23/2020
 Accessed: 04/24/2024

General information

Provisional. A provisional ecological site description has undergone quality control and quality assurance review. It contains a working state and transition model and enough information to identify the ecological site.

Classification relationships

None.

Associated sites

R010XY019ID	South Slope Loamy 12-16 PZ ARTRX/PSSPS
R010XY025ID	Shallow Stony Loam 12-20 PZ ARTRX/PSSPS

Similar sites

R010XY016ID	Shallow South Stony 12-16 PZ ARTRX/PSSPS
-------------	---

Table 1. Dominant plant species

Tree	Not specified
Shrub	Not specified
Herbaceous	Not specified

Physiographic features

This site occurs from valley bottoms to mountain ridgetops generally with southerly exposures. Slopes range from 30-75 percent. Elevation ranges between 2400-5000 feet (732-1525 m).

This site occurs on rolling to very steep slopes up to 90 percent, generally with southerly exposures. Slopes most commonly range from 30 to 75 percent. Elevation ranges between 2400-5000 feet (732-1525 m).

Table 2. Representative physiographic features

Landforms	(1) Hill (2) Structural bench (3) Mountain slope
Elevation	2,400–5,000 ft
Slope	30–75%
Water table depth	60 in
Aspect	S

Climatic features

The elevation of MLRA 10 ranges from 1791 feet to 9236 feet, with a mean of 4602 feet. Overall, elevation increases from west to east. However, average annual precipitation decreases from west to east, ranging from 16.59 inches to 22.17 inches, with a mean of 19.56 inches, based on 7 long term climate stations throughout the MLRA. In general, precipitation peaks in December and January, with a steady decline to a low in July and August, then a steep increase during the autumn months. Most of the winter precipitation falls as snow, and maximum annual snowfalls of up to 82 inches have been recorded.

There is considerable variation in temperature throughout the year. Temperatures as low as -52° Fahrenheit and as high as 117° Fahrenheit are on record. Some areas have recorded the occurrence of more than 50 days with temperatures above 90° Fahrenheit. The average maximum annual temperature is 63 degrees F, while the average minimum temperature is 36.2 degrees F. The frost-free period can range from 128 to 152 days, while the freeze-free period can be from 164 to 189 days.

Both the average morning and average afternoon relative humidity values are lowest in July and August, and are below the national average. The number of clear, sunny days peaks during this same period, and is higher than the national average. During the Spring and Summer months high-intensity convective thunderstorms are not unusual.

Table 3. Representative climatic features

Frost-free period (average)	152 days
Freeze-free period (average)	189 days
Precipitation total (average)	22 in

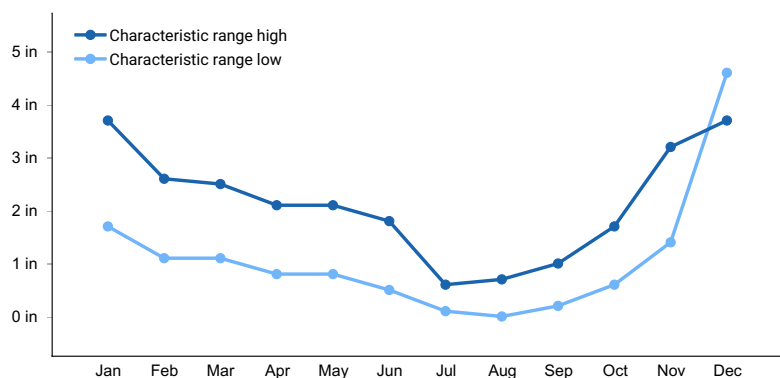

Figure 1. Monthly precipitation range

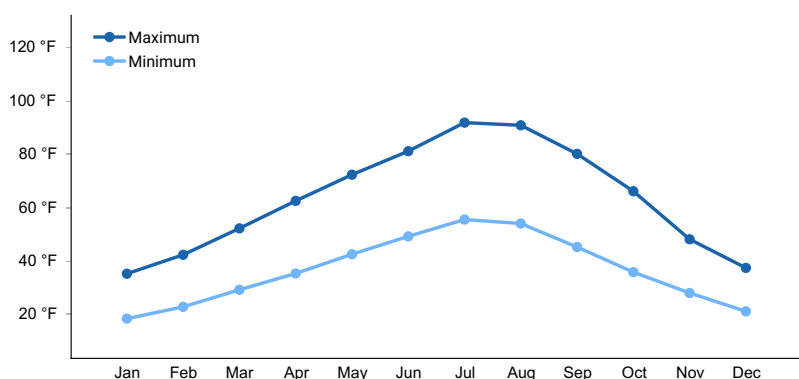

Figure 2. Monthly average minimum and maximum temperature

Influencing water features

This site is not influenced by adjacent wetlands, streams or run on.

Soil features

The soils supporting this site are very shallow to shallow underlain with bedrock. The soils on this site are well drained, with moderately slow to moderate permeability. Runoff is medium to very high. The erosion hazard is moderate to very severe by water. The available water capacity is very low. The surface texture is very stony or very

gravelly loam. These soils are characterized by a xeric soil moisture. Soil temperature regime is mesic.

Soil Series Correlated to this Ecological Site

Gwin Flybow

Table 4. Representative soil features

Surface texture	(1) Very stony loam (2) Very gravelly (3) Gravelly
Drainage class	Well drained
Permeability class	Moderately slow to moderate
Soil depth	4–20 in
Surface fragment cover <=3"	20–45%
Surface fragment cover >3"	0–30%
Available water capacity (0-40in)	0.4–2.2 in
Calcium carbonate equivalent (0-40in)	0%
Electrical conductivity (0-40in)	0 mmhos/cm
Sodium adsorption ratio (0-40in)	0
Soil reaction (1:1 water) (0-40in)	6.1–7.3
Subsurface fragment volume <=3" (Depth not specified)	0%
Subsurface fragment volume >3" (Depth not specified)	55–75%

Ecological dynamics

The dominant visual aspect of this site is grassland with bluebunch wheatgrass most dominant. Composition by weight is approximately 75-85 percent grasses, 10-15 percent forbs and T-3 percent shrubs. Disturbance leading to cover deterioration opens this site to Sandberg bluegrass and annual grass and forb increase or invasion.

In the last few thousand years, this site has evolved in a semi-arid climate characterized by dry summers and cold, wet winters. Herbivory has historically occurred on this site at low levels of utilization. Herbivores include mule deer, Rocky Mountain elk and lagomorphs and small rodents. Fire has historically occurred on the site at intervals of 50-70years. The Reference Plant Community Phase of this site is dominated by bluebunch wheatgrass and Sandberg bluegrass. Subdominant species include arrowleaf balsamroot, buckwheat, low fleabane, longleaf phlox, antelope bitterbrush and rabbitbrush. Total annual production is 600 pounds per acre (672 kilograms per hectare) in a normal year. Production in a favorable year is 800 pounds per acre (896kilograms per hectare). Production in an unfavorable year is 400 pounds per acre (448 kilograms per hectare). Structurally, cool season deep-rooted perennial bunchgrasses and shallow-rooted bunchgrasses are co-dominant, followed by perennial forbs being sub-dominant.

The Reference State (State 1) moves through many phases depending on the natural and man-made forces that impact the community over time. State 1, described later, indicates some of these phases. The Reference Plant Community Phase is Phase A. The plant species composition of Phase A is listed later under "Reference Plant community Phase Plant Species Composition".

This site is suited for late spring, fall and early winter grazing by livestock. Mule deer and Rocky Mountain elk use the site during the same period. Upland game birds such as chukars and Hungarian partridge use the site for feeding, nesting, and roosting. Due to the stony soils the site is fairly resistant to forces that may degrade it.

Impacts on the Plant Community.

Influence of fire:

In the absence of normal fire frequency, antelope bitterbrush can gradually increase on the site. A slight decrease in grasses and forbs would be expected as shrubs increase

When fires become more frequent than historic levels (50-70 years), bitterbrush is reduced significantly. Rabbitbrush can increase slightly. With continued short fire frequency, bitterbrush can be completely eliminated along with many of the desirable understory species such as bluebunch wheatgrass. These species may be replaced by Sandberg bluegrass and bulbous bluegrass along with a variety of annual and perennial forbs including noxious and invasive plants. Cheatgrass and medusahead will invade the site. These fine fuels will increase the fire frequency.

Influence of improper grazing management:

Season-long grazing and/or excessive utilization can be very detrimental to this site. This type of management leads to reduced vigor of the bunchgrasses. With reduced vigor, recruitment of these species declines. As these species decline, the plant community becomes susceptible to increase in Sandberg bluegrass and noxious and invasive plants.

Continued improper grazing management influences fire frequency by increasing fine fuels. If cheatgrass and/or medusahead increase due to improper grazing management and become co-dominant with Sandberg bluegrass and other annuals, fires become more frequent.

Proper grazing management that addresses frequency, duration, and intensity of grazing over time, can also keep fine fuels from developing, thereby reducing fire frequency. A planned grazing system can be developed to intentionally accumulate fine fuels in preparation of a prescribed burn. Any brush management should be carefully planned, as a reduction in shrubs without a suitable understory of perennial bunchgrasses can increase cheatgrass and/or medusahead which will lead to more frequent fire intervals.

Weather influences:

Above normal precipitation in March, April and May can dramatically increase total annual production of the plant community. These weather patterns can also increase viable seed production of desirable species to provide for recruitment. Likewise, below normal precipitation during these spring months can significantly reduce total annual production and be detrimental to viable seed production. Overall plant composition is normally not affected when perennials have good vigor.

Below normal temperatures in the spring can have an adverse impact on total production regardless of the precipitation. An early, hard freeze can occasionally kill some plants.

Prolonged drought adversely affects this plant community in several ways. Vigor, recruitment, and production are usually reduced. Mortality can occur. Prolonged drought can lead to a reduction in fire frequency.

Influence of insects and disease:

Outbreaks of insects and disease can affect vegetation health. Outbreaks of the black grass bug can reduce the vigor of bluebunch wheatgrass and reduce its palatability. Outbreaks of Mormon crickets and grasshoppers can reduce the vigor of bluebunch wheatgrass if their numbers are high in two or more consecutive years.

Influence of noxious and invasive plants:

Many of these species add to the fine-fuel component and lead to increased fire frequency.

Perennial and annual invasive species compete with desirable plants for moisture and nutrients. The result is reduced production and change in composition of the understory.

Influence of wildlife:

Big game animals utilize this site in late spring, fall and early winter. Their numbers are seldom high enough to adversely affect the plant community. Herbivory can be detrimental to bitterbrush when livestock grazing and browsing by big game occurs at the same time and season. This will occur when both kinds of animal are using the plant in the late summer or fall. The adverse impact is excessive use of the current year's leader growth.

Watershed:

Decreased infiltration and increased runoff occur with a decrease in bluebunch wheatgrass. This composition change can affect nutrient and water cycles. Increased runoff also causes sheet and rill erosion. Abnormally short fire frequency also gives the same results, but to a lesser degree. The long term effect is a transition to a different state.

Plant Community and Sequence:

Transition pathways between common vegetation states and phases:

State 1.

Phase A to B. Develops with improper grazing management and in the absence of fire.

Phase A to C. Develops with fire.

Phase B to A. Develops with prescribed grazing and no fire.

Phase C to A. Develops with prescribed grazing and no fire.

State 1 Phase C to State 2. Develops through frequent fire or improper grazing management. Invasive grasses and weeds are dominating the plant community and result in frequent fires. Erosion is increasing. The site has crossed the threshold. It is not economically feasible to move this state back towards State 1.

State 2 to unknown site. Excessive soil loss and changes in the hydrologic cycle caused by continued improper grazing management and/or frequent fire cause this state to retrogress to a new site with reduced potential. It is not economically feasible to move this state back towards State 1.

Practice Limitations.

Only slight limitations exist on this site for implementation of vegetation management practices. Domestic livestock can generally move freely across the site, however, on steeper slopes movement is somewhat limited. Due to steep slopes and shallow stony soils, installation of facilitating practices is difficult. Severe limitations exist for seeding by ground moving equipment due to the shallow, steep, and stony soils.

State and transition model

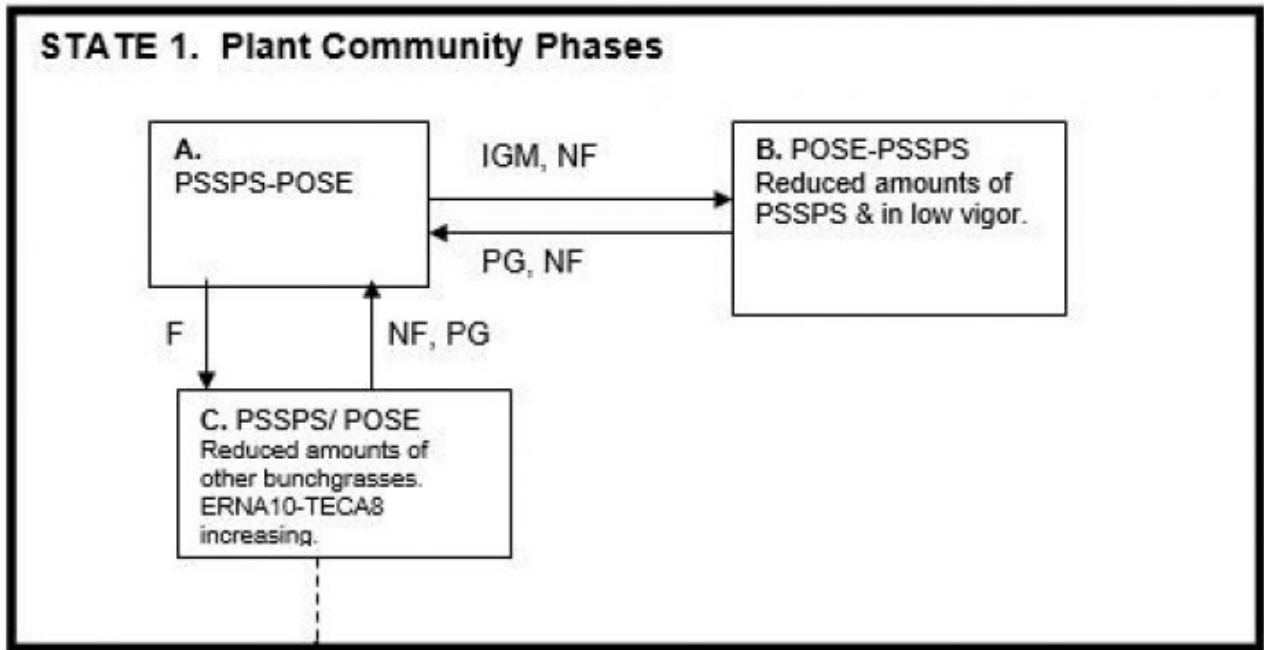

Plant Legend States 1 & 2

- PSSPS - Bluebunch Wheatgrass
- POSE - Sandberg Bluegrass
- ERNA10- Tall Gray Rabbitbrush
- TECA2 - Gray Horsebrush
- BRTE - Cheatgrass

**State 1
State 1 Phase A**

**Community 1.1
State 1 Phase A**

State 1, Phase A, Reference Plant Community Phase. This plant community has bluebunch wheatgrass and Sandberg bluegrass as co-dominants in the overstory. Few shrubs occur on the site. Prominent forbs include buckwheat, arrowleaf balsamroot and longleaf phlox. Natural fire frequency is 50-70 years.

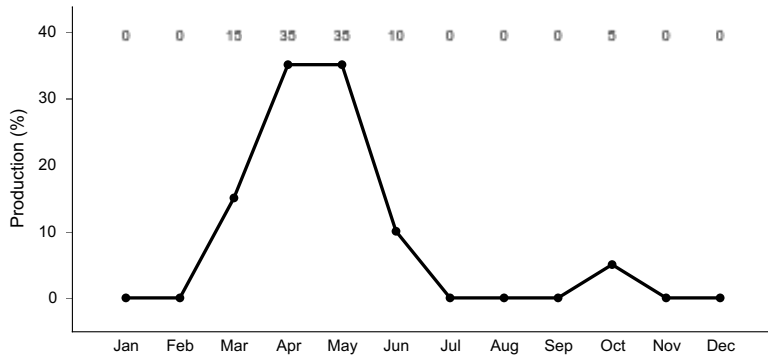

Figure 3. Plant community growth curve (percent production by month). ID0907, ARTRW8/PSSPS LOW PRECIP..

State 2
State 1 Phase B

Community 2.1
State 1 Phase B

State 1, Phase B. This plant community is dominated by Sandberg bluegrass. Bluebunch wheatgrass is still present in the plant community but is in low vigor. Cheatgrass, medusahead and noxious invasive species may be increasing. This state has developed due to improper grazing management and lack of fire.

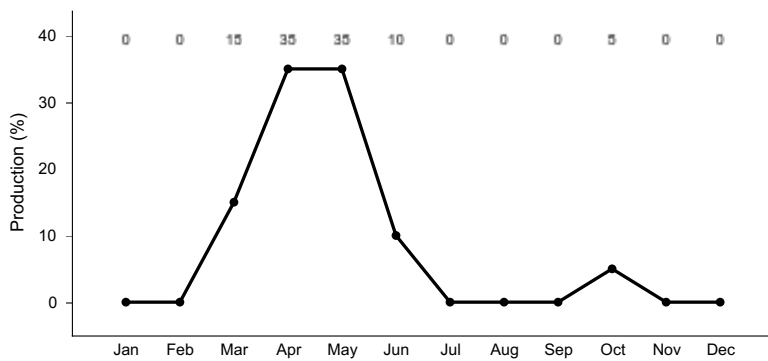

Figure 4. Plant community growth curve (percent production by month). ID0907, ARTRW8/PSSPS LOW PRECIP..

State 3
State 1 Phase C

Community 3.1
State 1 Phase C

State 1, Phase C. This plant community is dominated by bluebunch wheatgrass and Sandberg bluegrass. Forbs remain about in the same proportion as Plant Community A. Rabbitbrush and horsebrush are increasing. Some cheatgrass, medusahead and noxious species may have invaded the site. This plant community is the result of wildfire.

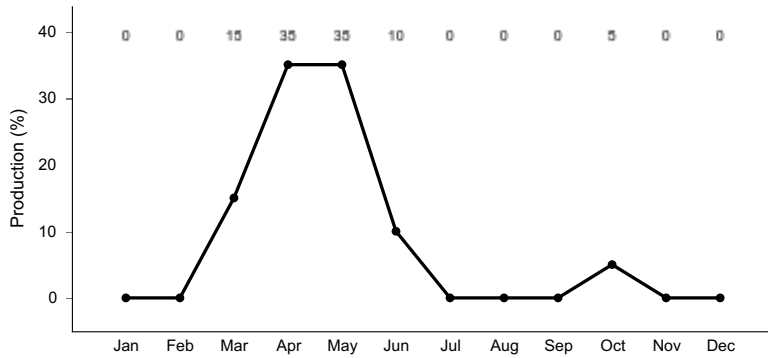

Figure 5. Plant community growth curve (percent production by month). ID0907, ARTRW8/PSSPS LOW PRECIP..

**State 4
State 2**

**Community 4.1
State 2**

State 2. This plant community is dominated by Sandberg bluegrass, cheatgrass and other annuals. Root sprouting shrubs such as rabbitbrush and horsebrush can be present, dependent upon, how frequent, fire has occurred. Some soil loss has occurred. This state has developed due to frequent fires or improper grazing management. The site has crossed the threshold. It is not economically feasible to move this state back towards State 1.

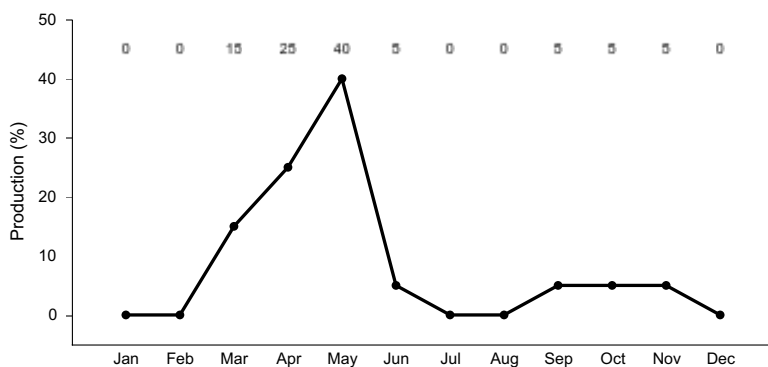

Figure 6. Plant community growth curve (percent production by month). ID0911, D25 POSE/BRTE/ANNUALS.

**State 5
State 3**

**Community 5.1
State 3**

Additional community tables

Animal community

Wildlife Interpretations.
Animal Community – Wildlife Interpretations

This rangeland ecological site provides diverse habitat for many native wildlife species. The plant community dominated by herbaceous vegetation favors grazers like elk and pronghorn antelope. Important seasonal habitat is provided for resident and migratory animals including western toad, western rattlesnake, shrews, jackrabbits, ground squirrels, mice, coyote, red fox, badger, sage-grouse, Ferruginous hawk, prairie falcon, horned lark and western meadowlark. Changes in the plant community composition can reduce the numbers and diversity of wildlife species in the area. Encroachment of noxious and invasive plant species (cheatgrass and medusahead) can

replace native plant species which provide critical feed, brood-rearing and nesting cover for a variety of native wildlife. Water features are sparse provided by seasonal streams, artificial water catchments and springs.

State 1 Phase 1.1 - Bluebunch Wheatgrass/ Sandberg Bluegrass/ Arrowleaf Balsamroot Reference Plant Community (RPC): This plant community provides a diversity of grasses and forbs, used by native insect communities that assist in pollination. The reptile and amphibian community is represented by leopard lizard, short horned lizard, western skink, western rattlesnake, western toad, boreal chorus frog and northern leopard frog. Amphibians are associated with springs and isolated water bodies adjacent to this plant community. Spring developments that capture all available water would preclude the use of this site by amphibians. The plant community supports a variety of migratory and resident avian species that specialize in grassland plant communities for food, brood-rearing and nesting cover. They include savannah sparrow, grasshopper sparrow, vesper sparrow, horned lark and western meadowlark. This plant community provides brood-rearing habitat for sage-grouse when adjacent to suitable sagebrush cover. The plant community supports seasonal needs of large mammals (mule deer, antelope, and elk) providing forage and cover on a seasonal basis. Bluebunch wheatgrass is preferred forage for elk, antelope and deer. The south facing slopes would offer a longer foraging season for mule deer and elk. A diverse small mammal population including voles, kangaroo rats, jackrabbits, deer mouse, badger and yellow-bellied marmots would utilize this community.

State 1 Phase 1.2 - Sandberg Bluegrass/ Bluebunch Wheatgrass Plant Community: This phase has developed due to improper grazing management and no fire. The site is less attractive to Phase 1.1 wildlife due to the change in dominance of grasses and reduced structural diversity. Insect diversity and numbers are assumed to be similar to Phase 1.1. The reptile community is represented by leopard lizard, short horned lizard, western skink, western rattlesnake, and western toad. Amphibians may include boreal chorus frog and northern leopard frog where springs are present. Spring developments that capture all available water would preclude the use of the area by amphibians. The plant community supports a variety of migratory and resident avian species that specialize in grassland plant communities for food, brood-rearing and nesting cover. Avian species present would be similar to Phase 1.1 species when under proper grazing management. The change in dominance of the community to sandberg bluegrass provides limited forage habitat (early spring and fall) for a shorter period of time, for mule deer, antelope, and elk. Small mammal population would be similar to Phase 1.1.

State 1 Phase 1.3 - Bluebunch Wheatgrass/ Sandberg Bluegrass Plant Community: This plant community is the result of fire. Insect diversity would be similar to Phase 1.1 plant community. An increase in rabbitbrush would add fall pollinator habitat. The reptile community would be similar to Phase 1.1, including short horned lizard, western skink and western rattlesnakes. This plant community provides brood-rearing habitat for sage-grouse when adjacent to suitable sagebrush cover. The change in herbaceous vegetation improves habitat for grassland avian species (horned lark and western meadowlark).

The change in plant species would shorten seasonal forage use by elk, antelope and mule deer. South facing slopes would offer a longer foraging season for mule deer and elk. The increase in shrubs would add limited young of year cover and thermal cover for large mammals. A diverse small mammal population including voles, kangaroo rats, jackrabbits, deer mouse, badger and yellow-bellied marmots would utilize this community.

State 2 – Sandberg Bluegrass/ Cheatgrass/ Annual Grasses/ Invasive Plant Community: This state has developed due to frequent fires and/or improper grazing management. The plant community supports harmful insects, such as grasshoppers with favorable breeding conditions. The plant community would support a very limited population of pollinators. Most reptilian species are not supported with food, water or cover. Diversity of grassland avian species is reduced due to poor cover and food. Birds of prey including hawks and falcons may range throughout these areas looking for prey species. Large mammals may utilize the herbaceous vegetation in the early part of the year when the invasive annuals (cheatgrass) are more palatable. At other times of the year large mammals would not regularly utilize these areas due to poor forage and cover conditions. The populations of small mammals would be dominated by open grassland species like the Columbian ground squirrel.

Grazing Interpretations.

This site is suitable for late spring, fall and early winter grazing by livestock.

Estimated initial stocking rate will be determined with the landowner or decision-maker. They will be based on the inventory which includes species, composition, similarity index, production, past use history, season of use and seasonal preference. Calculations used to determine estimated initial stocking rate will be based on forage preference ratings

Hydrological functions

The soils in this site are in hydrologic group D. When hydrologic conditions of the vegetative cover are good, natural erosion hazard is slight to moderate.

Recreational uses

This site has slight recreational or aesthetic value. Hunting for mule deer, Rocky Mountain elk chukars and Hungarian partridge is popular on this site.

Wood products

None.

Other products

None.

Other information

Field Offices

Weiser, ID

Emmett, ID

Mountain Home, ID

Meridian, ID

Cascade, ID

Inventory data references

Information presented here has been derived from NRCS clipping and other inventory data. Also, field knowledge of range-trained personnel was used. Those involved in developing this site description include:

Dave Franzen, co-owner, Intermountain Rangeland Consultants, LLC

Jacy Gibbs, co-owner, Intermountain Rangeland Consultants, LLC

Jim Cornwell, Range Management Specialist, IASCD

Brendan Brazee, State Rangeland Management Specialist, NRCS, Idaho

Lee Brooks, Range Management Specialist, IASCD

Leah Juarros, Resource Soil Scientist, NRCS, Idaho

Type locality

Location 1: Washington County, ID	
Township/Range/Section	T15N R4W S13
General legal description	SW 1/4 Section 13

Other references

Hironaka, M., M.A. Fosberg, A. H. Winward. 1983. Sagebrush- Grass Habitat Types of Southern Idaho. University of Idaho. Moscow, Idaho. Bulletin Number 35

USDA Forest Service, Rocky Mountain Research Station. 2004. Restoring Western Ranges and Wildlands. General Technical Report RMRS-GTR-136-vols. 1-3.

USDA, NRCS.2001. The PLANTS Database, Version 3.1 (<http://plants.usda.gov>). National Plant Data Center, Baton Rouge, LA 70874-4490 USA

USDA, Forest Service, Fire Effects Information Database. 2004. www.fs.fed.us/database.

USDI Bureau of Land Management, US Geological Survey; USDA Natural Resources Conservation Service, Agricultural Research Service; Interpreting Indicators of Rangeland Health. Technical Reference 1734-6; version 4-

2005.

Approval

Kendra Moseley, 9/23/2020

Rangeland health reference sheet

Interpreting Indicators of Rangeland Health is a qualitative assessment protocol used to determine ecosystem condition based on benchmark characteristics described in the Reference Sheet. A suite of 17 (or more) indicators are typically considered in an assessment. The ecological site(s) representative of an assessment location must be known prior to applying the protocol and must be verified based on soils and climate. Current plant community cannot be used to identify the ecological site.

Author(s)/participant(s)	Dave Franzen and Jacy Gibbs Intermountain Range Consultants 17700 Fargo Rd. Wilder, ID 83676
Contact for lead author	Brendan Brazee, State Rangeland Management Specialist USDA-NRCS 9173 W. Barnes Drive, Suite C, Boise, ID 83709
Date	04/22/2009
Approved by	Kendra Moseley
Approval date	
Composition (Indicators 10 and 12) based on	Annual Production

Indicators

- Number and extent of rills:** can occur on this site due to steep slopes, limited water-holding capacity and percent bare ground. Gravel and stones on the surface reduces erosion

- Presence of water flow patterns:** water flow patterns are common on this site. When they occur they may be long, continuous and extensive

- Number and height of erosional pedestals or terracettes:** both are common on this site. Terracettes develop uphill from the large bunchgrasses and surface stones

- Bare ground from Ecological Site Description or other studies (rock, litter, lichen, moss, plant canopy are not bare ground):** ranges from 15-25 percent

- Number of gullies and erosion associated with gullies:** do not occur on this site.

- Extent of wind scoured, blowouts and/or depositional areas:** usually does not occur.

- Amount of litter movement (describe size and distance expected to travel):** fine litter in the interspaces may move

up to 5 feet or further following a significant run-off event. Terracettes and rocks can trap fine litter. Coarse litter generally does not move

8. **Soil surface (top few mm) resistance to erosion (stability values are averages - most sites will show a range of values):** Values should range from 4 to 6 but needs to be tested
-

9. **Soil surface structure and SOM content (include type of structure and A-horizon color and thickness):** the A or A1 horizon is typically 5 inches thick.
Structure ranges from weak very fine granular to strong coarse granular. Soil organic matter (SOM) ranges from 0.5 to 5 percent.
-

10. **Effect of community phase composition (relative proportion of different functional groups) and spatial distribution on infiltration and runoff:** bunchgrasses, especially deep-rooted perennials, slow run-off and increase infiltration. Terracettes provide a favorable micro-site for vegetation establishment which further increases infiltration
-

11. **Presence and thickness of compaction layer (usually none; describe soil profile features which may be mistaken for compaction on this site):** not present.
-

12. **Functional/Structural Groups (list in order of descending dominance by above-ground annual-production or live foliar cover using symbols: >>, >, = to indicate much greater than, greater than, and equal to):**

Dominant: cool season deep-rooted perennial bunchgrasses

Sub-dominant: perennial forbs>shallow rooted bunchgrasses

Other:

Additional:

13. **Amount of plant mortality and decadence (include which functional groups are expected to show mortality or decadence):** bitterbrush may become decadent in the absence of ungulate browsing. Bluebunch wheatgrass may become decadent in the absence of fire and large ungulate grazing
-

14. **Average percent litter cover (%) and depth (in):** annual litter cover in the interspaces will be 5-10 percent to a depth of <0.1. Fine litter can accumulate on the terracettes and behind surface stones
-

15. **Expected annual annual-production (this is TOTAL above-ground annual-production, not just forage annual-production):** is 600 lbs. per acre in a year with normal precipitation and temperatures. Production is normally low due to low infiltration, steep south aspect and moderate water holding capacity. Perennial grasses produce 75-85percent of the total, forbs 10-15 percent, and shrubs T-3 percent
-

16. **Potential invasive (including noxious) species (native and non-native).** List species which **BOTH** characterize degraded states and have the potential to become a dominant or co-dominant species on the ecological site if their future establishment and growth is not actively controlled by management interventions. Species that become dominant for only one to several years (e.g., short-term response to drought or wildfire) are not invasive plants. Note that unlike other indicators, we are describing what is **NOT** expected in the reference state for the ecological site: Cheatgrass, medusahead, bulbous bluegrass, rush skeletonweed, scotch thistle, spotted and diffuse knapweed
-

17. **Perennial plant reproductive capability:** all functional groups have the potential to reproduce in favorable years
-