

Ecological site R026XF010CA

Wet Meadow

Last updated: 4/10/2024
Accessed: 04/25/2024

General information

Provisional. A provisional ecological site description has undergone quality control and quality assurance review. It contains a working state and transition model and enough information to identify the ecological site.

MLRA notes

Major Land Resource Area (MLRA): 026X–Carson Basin and Mountains

The area lies within western Nevada and eastern California, with about 69 percent being within Nevada, and 31 percent being within California. Almost all this area is in the Great Basin Section of the Basin and Range Province of the Intermontane Plateaus. Isolated north-south trending mountain ranges are separated by aggraded desert plains. The mountains are uplifted fault blocks with steep side slopes. Most of the valleys are drained by three major rivers flowing east across this MLRA. A narrow strip along the western border of the area is in the Sierra Nevada Section of the Cascade-Sierra Mountains Province of the Pacific Mountain System. The Sierra Nevada Mountains are primarily a large fault block that has been uplifted with a dominant tilt to the west. This structure leaves an impressive wall of mountains directly west of this area. This helps create a rain shadow affect to MLRA 26. Parts of this eastern face, but mostly just the foothills, mark the western boundary of this area. Elevations range from about 3,806 feet (1,160 meters) on the west shore of Pyramid Lake to 11,653 feet (3,552 meters) on the summit of Mount Patterson in the Sweetwater Mountains.

Valley areas are dominantly composed of Quaternary alluvial deposits with Quaternary playa or alluvial flat deposits often occupying the lowest valley bottoms in the internally drained valleys, and river deposited alluvium being dominant in externally drained valleys. Hills and mountains are dominantly Tertiary andesitic flows, breccias, ash flow tuffs, rhyolite tuffs or granodioritic rocks. Quaternary basalt flows are present in lesser amounts, and Jurassic and Triassic limestone and shale, and Precambrian limestone and dolomite are also present in very limited amounts. Also of limited extent are glacial till deposits along the east flank of the Sierra Nevada Mountains, the result of alpine glaciation.

The average annual precipitation in this area is 5 to 36 inches (125 to 915 millimeters), increasing with elevation. Most of the rainfall occurs as high-intensity, convective storms in spring and autumn. Precipitation is mostly snow in winter. Summers are dry. The average annual temperature is 37 to 54 degrees F (3 to 12 degrees C). The freeze-free period averages 115 days and ranges from 40 to 195 days, decreasing in length with elevation.

The dominant soil orders in this MLRA are Aridisols and Mollisols. The soils in the area dominantly have a mesic soil temperature regime, an aridic or xeric soil moisture regime, and mixed or smectitic mineralogy. They generally are well drained, are clayey or loamy and commonly skeletal, and are very shallow to moderately deep.

This area supports shrub-grass vegetation characterized by big sagebrush. Low sagebrush and Lahontan sagebrush occur on some soils. Antelope bitterbrush, squirreltail, desert needlegrass, Thurber needlegrass, and Indian ricegrass are important associated plants. Green ephedra, Sandberg bluegrass, Anderson peachbrush, and several forb species also are common. Juniper-pinyon woodland is typical on mountain slopes. Jeffrey pine, lodgepole pine, white fir, and manzanita grow on the highest mountain slopes. Shadscale is the typical plant in the drier parts of the area. Sedges, rushes, and moisture-loving grasses grow on the wettest parts of the wet flood plains and terraces. Basin wildrye, alkali sacaton, saltgrass, buffaloberry, black greasewood, and rubber rabbitbrush grow on the drier sites that have a high concentration of salts.

Some of the major wildlife species in this area are mule deer, coyote, beaver, muskrat, jackrabbit, cottontail, raptors, pheasant, chukar, blue grouse, mountain quail, and mourning dove. The species of fish in the area include trout and catfish. The Lahontan cutthroat trout in the Truckee River is a threatened and endangered species.

LRU notes

The Mono-Adobe-Long Valleys LRU is comprised of the basins surrounding Mono Lake, Adobe Valley, and Long Valley to the southeast. Pleistocene and Holocene age alluvium and lacustrine deposits predominate. Ash layers occur from eruptions of the numerous volcanic domes that are mostly in adjacent LRUs. Soil temperature regimes are mesic and soil moisture regimes are aridic. Elevations range from 1310 to 2680 meters and slopes are typically less than 10 percent, however there are some ecological sites within the Mono-Adobe-Long Valleys LRU that are greater than 10 percent. Frost free days (FFD) range from 97-125.

Ecological site concept

The Wet Meadow site occurs in a bottom location, but not associated with a stream. Elevations are 6000 to 7200 feet. Slopes range from 0 to 8 percent. The soils that characterize this site are very deep and poorly drained and not influenced by salt. They formed in alluvium from mixed rock sources and volcanic ash. Surface textures are sandy loams. Water tables are from 6 to 48 inches.

Associated sites

R026XF016CA	Wet Sodic Meadow Site is located on salt influenced soils.
R026XF007CA	Sodic Meadow Site is located on salt influenced soils and has a deeper water table.

Similar sites

R026XF017CA	Moist Floodplain Site is associated with streams.
-------------	---

Table 1. Dominant plant species

Tree	Not specified
Shrub	Not specified
Herbaceous	(1) <i>Carex</i> (2) <i>Deschampsia cespitosa</i>

Physiographic features

This site occurs on stream, alluvial fan and lake terraces in bottom locations. Slopes range from 0 to 8 percent.

Table 2. Representative physiographic features

Landforms	(1) Alluvial fan (2) Stream terrace (3) Lake terrace
Runoff class	Very low to low
Flooding duration	Brief (2 to 7 days)
Flooding frequency	Occasional to frequent
Elevation	6,000–7,200 ft
Slope	0–8%
Water table depth	6–48 in

Climatic features

The climate on this site is characterized by cold winters (20 to 45 degrees F) and warm, mostly dry summers (40 to 85 degrees F). The average annual precipitation ranges from 8 to 16 inches, with most falling as snow from November to March.

Table 3. Representative climatic features

Frost-free period (characteristic range)	25-87 days
Freeze-free period (characteristic range)	58-116 days
Precipitation total (characteristic range)	8-16 in
Frost-free period (average)	56 days
Freeze-free period (average)	87 days
Precipitation total (average)	13 in

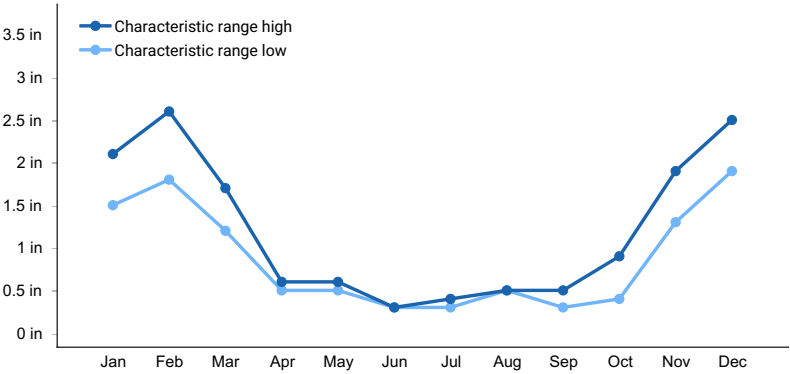

Figure 1. Monthly precipitation range

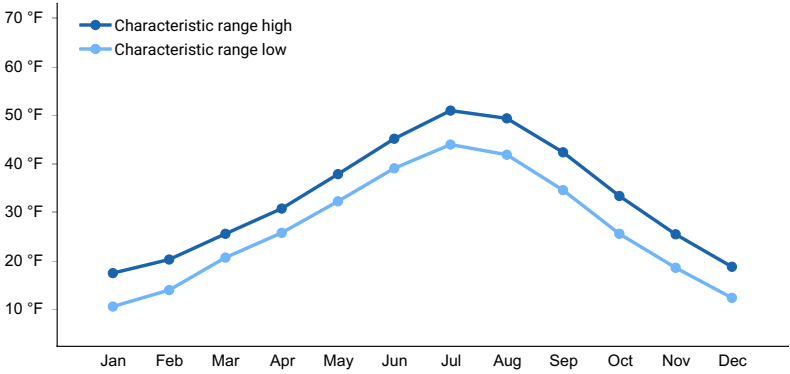

Figure 2. Monthly minimum temperature range

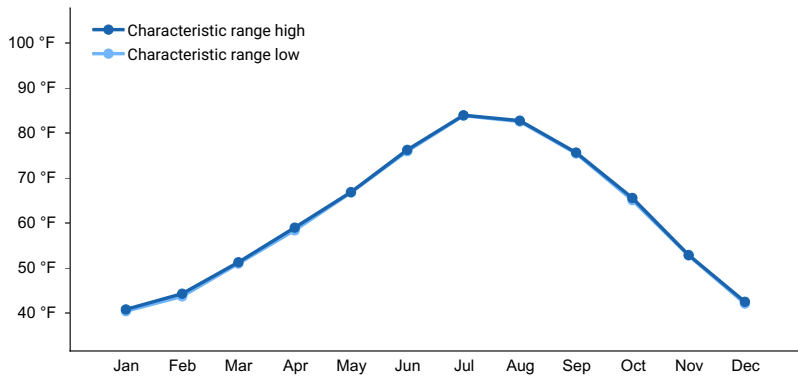

Figure 3. Monthly maximum temperature range

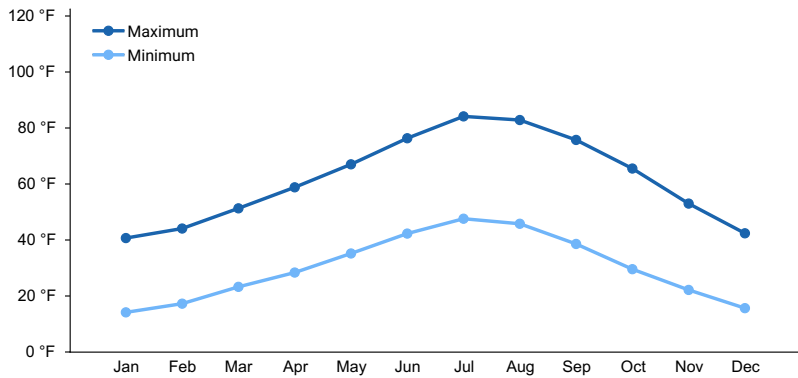

Figure 4. Monthly average minimum and maximum temperature

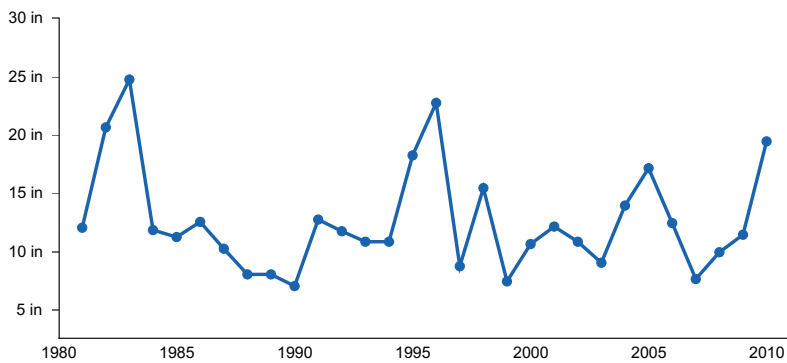

Figure 5. Annual precipitation pattern

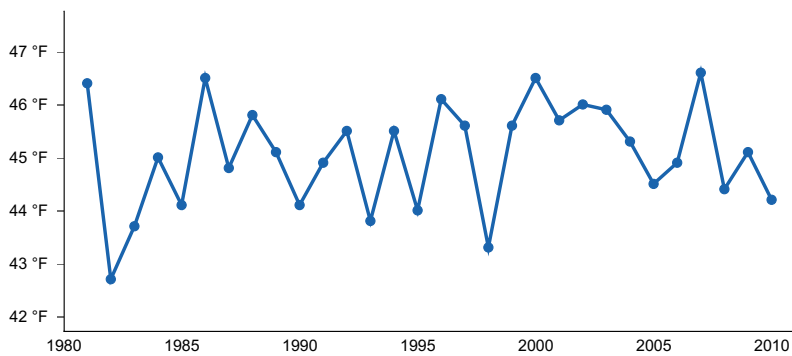

Figure 6. Annual average temperature pattern

Climate stations used

- (1) LEE VINING [USC00044881], Lee Vining, CA
- (2) BRIDGEPORT [USC00041072], Bridgeport, CA

Influencing water features

The Wet Meadow site occurs next to stream or wetland water features and is occasionally to frequently flooded for brief periods of time.

Soil features

The soils that characterize this site are very deep and poorly drained. They formed in alluvium from mixed rock sources and volcanic ash. Surface textures are sandy loams. Available water capacity is moderate and the hazard of water erosion is slight. Wind erosion hazard is slight. Effective rooting depth is 60 inches or more. Water tables are from 6 to 48 inches.

Soil Survey Areas, Soil Component (Mapunit Symbol):

CA 686: Aquandic Cryaquolls (5000); Longdrive (5020, 6060); Nohope (7010)

CA732: Aquents (169bo); Conway (104bo, 169bo, 170bo, 172bo, 354bo); Dehy (186bo); Watterson (169bo, 172bo, 227bo, 351bo, 354bo)

CA740: Watterson (227bo)

CA802: Aquents (169); Conway (104, 168, 169, 170, 172, 354); Dehy (186); Watterson (169, 172, 227, 351, 354)

The Watterson soil series is not a good fit for this ecological site and will need to be updated.

Table 4. Representative soil features

Parent material	(1) Volcanic ash (2) Alluvium
Surface texture	(1) Sandy loam
Drainage class	Poorly drained
Permeability class	Moderate to moderately rapid
Surface fragment cover <=3"	8–24%
Surface fragment cover >3"	0%
Available water capacity (Depth not specified)	2.3–4.1 in
Calcium carbonate equivalent (Depth not specified)	0%
Electrical conductivity (Depth not specified)	0 mmhos/cm
Sodium adsorption ratio (Depth not specified)	0
Soil reaction (1:1 water) (Depth not specified)	6.1–8.4
Subsurface fragment volume <=3" (Depth not specified)	13–30%
Subsurface fragment volume >3" (Depth not specified)	0%

Ecological dynamics

Nebraska sedge forms nearly pure stands where water flows over the soil surface but does not pond. On wetter areas, Nebraska sedge mixes with beaked sedge, and on drier sites, it can be found with tufted hairgrass and a host of other species.

Where management results in over use by livestock, tufted hairgrass, Nevada bluegrass, and the other palatable grasses and sedges decrease, while rush, wild iris, and other forbs become dominant. Species likely to invade this site include thistles, Kentucky bluegrass, and other annual grasses. Where stream channels become entrenched,

the water table is lowered allowing for the establishment of more drought-tolerant vegetation such as sagebrush and rabbitbrush.

State and transition model

Ecosystem states

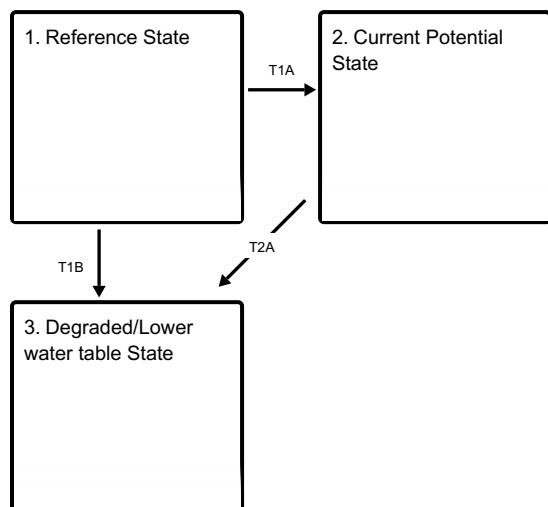

State 1 submodel, plant communities



State 2 submodel, plant communities

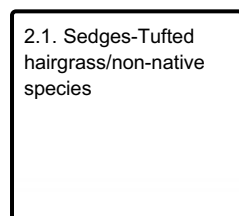

State 3 submodel, plant communities

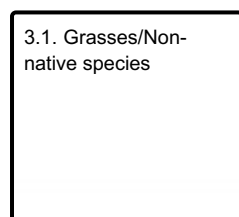

State 1 Reference State

The Reference State represents the plant communities that are adapted to a high water table under a natural disturbance regime. The water table is quite variable across this site and the depth of the available water will largely determine the plants present on the site. Drier locations will have plants adapted to drier soil conditions, while wetter locations will have plants adapted to wetter soil conditions (sedge/rushes).

Community 1.1 Sedges-Tufted hairgrass

The reference plant community is dominated by sedges and tufted hairgrass. Potential vegetation composition is

about 85 percent grasses and grass-like plants and 15 percent perennial forbs. Approximate ground cover (basal and crown) is 80 to 90 percent.

Dominant plant species

- willow (*Salix*), shrub
- Woods' rose (*Rosa woodsii*), shrub
- tufted hairgrass (*Deschampsia cespitosa*), grass
- sedge (*Carex*), grass

State 2

Current Potential State

The Current Potential State is similar to the Reference State except the plant communities have non-native species present. The presence of non-native species, especially those that are invasive, lowers the resistance and resiliency of the state. Invasive/non-native plants that can come in with a high water table are meadow foxtail (*Alopecurus arundinaceus*), quackgrass (*Elymus repens*), reed canarygrass (*Phalaris arundinacea*), and Kentucky bluegrass (*Poa pratensis*). These species are also more tolerant of grazing and can increase and may become dominant on the site.

Community 2.1

Sedges-Tufted hairgrass/non-native species

Community Phase 2.1 is similar to Community Phase 1.1 with the exception of non-native plants establishment in the plant community.

State 3

Degraded/Lower water table State

The Degraded/Lower water table State develops after a permanent lowering of the water table. This can occur from excessive grazing that can cause meadow downcutting or through artificial meadow drainage to decrease soil saturation. State 1 and State 2 can transition to this state. The site has crossed the threshold. This state cannot be returned to State 1 without raising the water table.

Community 3.1

Grasses/Non-native species

Plants that are adapted to drier soil conditions are present in this community phase.

Transition T1A

State 1 to 2

Non-native species establishment. Often concurrent with over use by livestock.

Transition T1B

State 1 to 3

This transition can occur with artificial drainage of the site, which reduces the availability of water and reduces soil moisture.

Transition T2A

State 2 to 3

This transition can occur with artificial drainage of the site, which reduces the availability of water and reduces soil moisture.

Additional community tables

Inventory data references

NASIS data for CA686, CA732, CA740, and CA802

Type locality

Location 1: Mono County, CA	
Township/Range/Section	T4S R29E S9
General legal description	Along lakeshore of Crowley Lake.

Contributors

P.Novak/V.Burlingame/J.Hanson

Approval

Kendra Moseley, 4/10/2024

Rangeland health reference sheet

Interpreting Indicators of Rangeland Health is a qualitative assessment protocol used to determine ecosystem condition based on benchmark characteristics described in the Reference Sheet. A suite of 17 (or more) indicators are typically considered in an assessment. The ecological site(s) representative of an assessment location must be known prior to applying the protocol and must be verified based on soils and climate. Current plant community cannot be used to identify the ecological site.

Author(s)/participant(s)	
Contact for lead author	
Date	04/25/2024
Approved by	Kendra Moseley
Approval date	
Composition (Indicators 10 and 12) based on	Annual Production

Indicators

1. **Number and extent of rills:**

2. **Presence of water flow patterns:**

3. **Number and height of erosional pedestals or terracettes:**

4. **Bare ground from Ecological Site Description or other studies (rock, litter, lichen, moss, plant canopy are not bare ground):**

5. **Number of gullies and erosion associated with gullies:**

-
6. **Extent of wind scoured, blowouts and/or depositional areas:**
-
7. **Amount of litter movement (describe size and distance expected to travel):**
-
8. **Soil surface (top few mm) resistance to erosion (stability values are averages - most sites will show a range of values):**
-
9. **Soil surface structure and SOM content (include type of structure and A-horizon color and thickness):**
-
10. **Effect of community phase composition (relative proportion of different functional groups) and spatial distribution on infiltration and runoff:**
-
11. **Presence and thickness of compaction layer (usually none; describe soil profile features which may be mistaken for compaction on this site):**
-
12. **Functional/Structural Groups (list in order of descending dominance by above-ground annual-production or live foliar cover using symbols: >>, >, = to indicate much greater than, greater than, and equal to):**
- Dominant:
- Sub-dominant:
- Other:
- Additional:
-
13. **Amount of plant mortality and decadence (include which functional groups are expected to show mortality or decadence):**
-
14. **Average percent litter cover (%) and depth (in):**
-
15. **Expected annual annual-production (this is TOTAL above-ground annual-production, not just forage annual-production):**
-
16. **Potential invasive (including noxious) species (native and non-native). List species which BOTH characterize degraded states and have the potential to become a dominant or co-dominant species on the ecological site if their future establishment and growth is not actively controlled by management interventions. Species that become dominant for only one to several years (e.g., short-term response to drought or wildfire) are not**

invasive plants. Note that unlike other indicators, we are describing what is NOT expected in the reference state for the ecological site:

17. Perennial plant reproductive capability:
