

Ecological site R026XF018CA Streambank

Last updated: 4/10/2024
Accessed: 04/25/2024

General information

Provisional. A provisional ecological site description has undergone quality control and quality assurance review. It contains a working state and transition model and enough information to identify the ecological site.

MLRA notes

Major Land Resource Area (MLRA): 026X–Carson Basin and Mountains

The area lies within western Nevada and eastern California, with about 69 percent being within Nevada, and 31 percent being within California. Almost all this area is in the Great Basin Section of the Basin and Range Province of the Intermontane Plateaus. Isolated north-south trending mountain ranges are separated by aggraded desert plains. The mountains are uplifted fault blocks with steep side slopes. Most of the valleys are drained by three major rivers flowing east across this MLRA. A narrow strip along the western border of the area is in the Sierra Nevada Section of the Cascade-Sierra Mountains Province of the Pacific Mountain System. The Sierra Nevada Mountains are primarily a large fault block that has been uplifted with a dominant tilt to the west. This structure leaves an impressive wall of mountains directly west of this area. This helps create a rain shadow affect to MLRA 26. Parts of this eastern face, but mostly just the foothills, mark the western boundary of this area. Elevations range from about 3,806 feet (1,160 meters) on the west shore of Pyramid Lake to 11,653 feet (3,552 meters) on the summit of Mount Patterson in the Sweetwater Mountains.

Valley areas are dominantly composed of Quaternary alluvial deposits with Quaternary playa or alluvial flat deposits often occupying the lowest valley bottoms in the internally drained valleys, and river deposited alluvium being dominant in externally drained valleys. Hills and mountains are dominantly Tertiary andesitic flows, breccias, ash flow tuffs, rhyolite tuffs or granodioritic rocks. Quaternary basalt flows are present in lesser amounts, and Jurassic and Triassic limestone and shale, and Precambrian limestone and dolomite are also present in very limited amounts. Also of limited extent are glacial till deposits along the east flank of the Sierra Nevada Mountains, the result of alpine glaciation.

The average annual precipitation in this area is 5 to 36 inches (125 to 915 millimeters), increasing with elevation. Most of the rainfall occurs as high-intensity, convective storms in spring and autumn. Precipitation is mostly snow in winter. Summers are dry. The average annual temperature is 37 to 54 degrees F (3 to 12 degrees C). The freeze-free period averages 115 days and ranges from 40 to 195 days, decreasing in length with elevation.

The dominant soil orders in this MLRA are Aridisols and Mollisols. The soils in the area dominantly have a mesic soil temperature regime, an aridic or xeric soil moisture regime, and mixed or smectitic mineralogy. They generally are well drained, are clayey or loamy and commonly skeletal, and are very shallow to moderately deep.

This area supports shrub-grass vegetation characterized by big sagebrush. Low sagebrush and Lahontan sagebrush occur on some soils. Antelope bitterbrush, squirreltail, desert needlegrass, Thurber needlegrass, and Indian ricegrass are important associated plants. Green ephedra, Sandberg bluegrass, Anderson peachbrush, and several forb species also are common. Juniper-pinyon woodland is typical on mountain slopes. Jeffrey pine, lodgepole pine, white fir, and manzanita grow on the highest mountain slopes. Shadscale is the typical plant in the drier parts of the area. Sedges, rushes, and moisture-loving grasses grow on the wettest parts of the wet flood plains and terraces. Basin wildrye, alkali sacaton, saltgrass, buffaloberry, black greasewood, and rubber rabbitbrush grow on the drier sites that have a high concentration of salts.

Some of the major wildlife species in this area are mule deer, coyote, beaver, muskrat, jackrabbit, cottontail, raptors, pheasant, chukar, blue grouse, mountain quail, and mourning dove. The species of fish in the area include trout and catfish. The Lahontan cutthroat trout in the Truckee River is a threatened and endangered species.

LRU notes

The Bodie Hills LRU straddles the California-Nevada state boundary, just north of Mono Lake. The area is underlain by late Miocene age volcanic fields with upper Miocene and Pliocene sedimentary deposits over top. The youngest faults in the area are north and north-east striking. Extensive zones of hydrothermally altered rocks and large mineral deposits, including gold and silver rich veins, formed during hydrothermally active periods of the Miocene (John et al. 2015). A primary distinguishing factor between the Bodie Hills and other hills in MLRA 26 is the dominance of volcanic parent material. Elevations range from 2170 to 2650 meters and slopes typically range from 5 to 35 percent. FFD range from 75-105.

Ecological site concept

The Streambank site occurs along perennial streams of mountain valleys on stream terraces and floodplains. The soil is deep and very cobbly on the surface. The Streambank site can be flooded by adjacent streams very long to brief intervals. The water table depth is between 0 and 18 inches. The dominant vegetation is yellow willow (*Salix lutea*) and sedges (*Carex*).

Table 1. Dominant plant species

Tree	Not specified
Shrub	(1) <i>Salix lutea</i>
Herbaceous	(1) <i>Carex</i>

Physiographic features

The Streambank site occurs on stream terraces and flood plains of perennial streams in mountain valleys. Slopes range from 0 to 8 percent.

Table 2. Representative physiographic features

Landforms	(1) Stream terrace (2) Flood plain
Flooding duration	Brief (2 to 7 days) to very long (more than 30 days)
Flooding frequency	None to frequent
Elevation	6,000–8,800 ft
Slope	0–8%
Water table depth	0–18 in
Aspect	Aspect is not a significant factor

Climatic features

The Streambank site receives additional moisture from the close proximity to a stream.

Table 3. Representative climatic features

Frost-free period (characteristic range)	1-3 days
Freeze-free period (characteristic range)	8-31 days
Precipitation total (characteristic range)	10-11 in
Frost-free period (actual range)	0-4 days

Freeze-free period (actual range)	2-37 days
Precipitation total (actual range)	10-12 in
Frost-free period (average)	2 days
Freeze-free period (average)	20 days
Precipitation total (average)	11 in

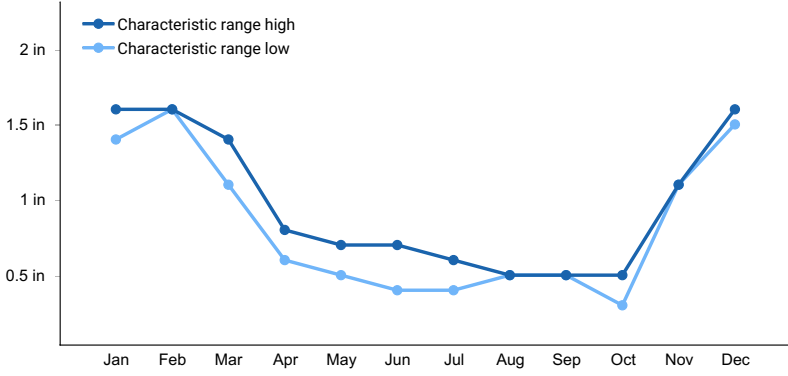

Figure 1. Monthly precipitation range

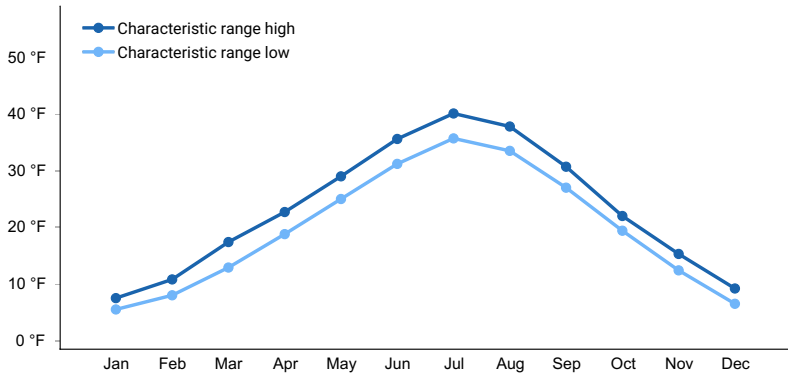

Figure 2. Monthly minimum temperature range

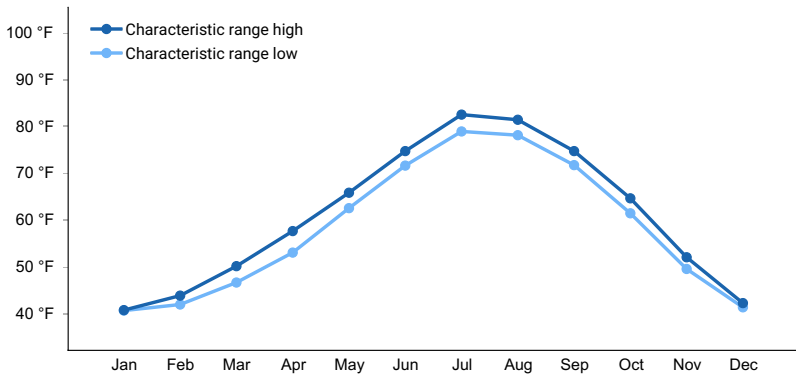

Figure 3. Monthly maximum temperature range

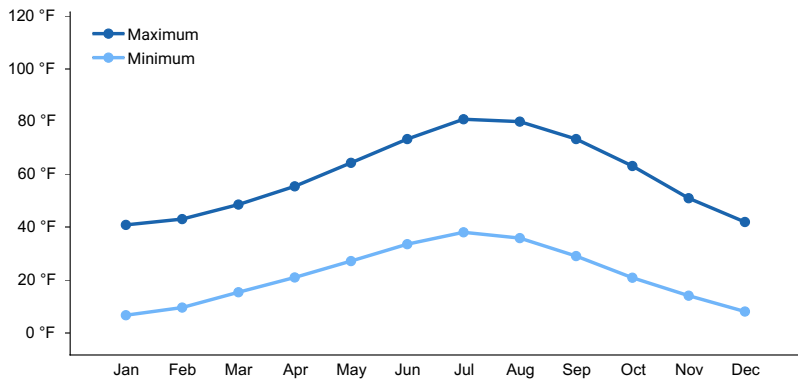

Figure 4. Monthly average minimum and maximum temperature

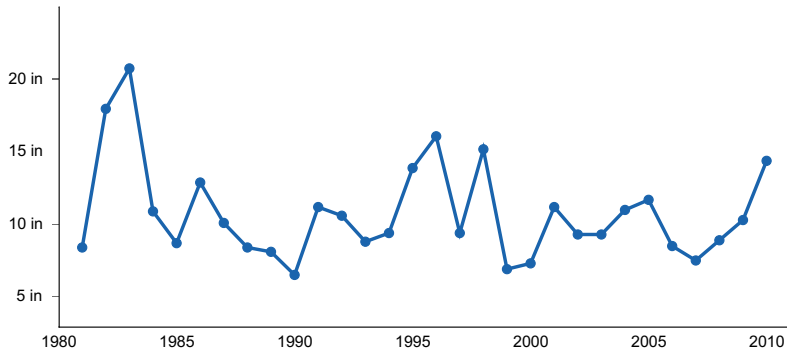

Figure 5. Annual precipitation pattern

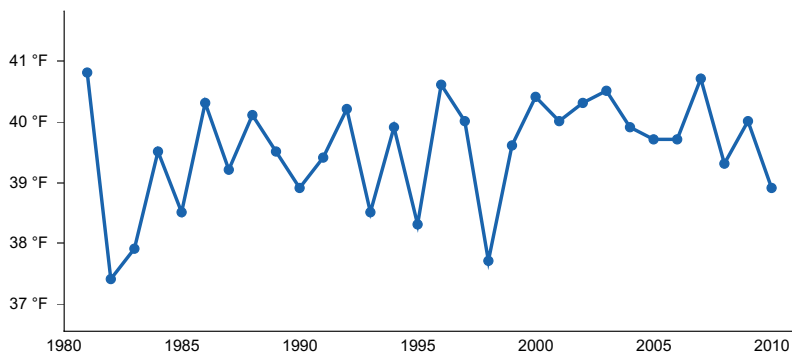

Figure 6. Annual average temperature pattern

Climate stations used

- (1) BODIE CA ST HISTORIC PARK [USC00040943], Bridgeport, CA
- (2) BRIDGEPORT [USC00041072], Bridgeport, CA

Influencing water features

The Streambank site occurs on stream terraces and flood plains and may be flooded during high runoff in the spring.

Soil features

The soils are deep and very poorly on flood plains to well drained on stream terraces. The soil was formed in volcanic ash and/or alluvium derived from mixed rocks. The water holding capacity is low to moderate. The soil surface texture is very cobbly sandy loam/loamy sand or loam.

Table 4. Representative soil features

Parent material	(1) Volcanic ash (2) Alluvium
Surface texture	(1) Very cobbly loamy sand (2) Very cobbly sandy loam (3) Loam
Family particle size	(1) Ashy-skeletal
Drainage class	Very poorly drained to well drained
Permeability class	Moderate to moderately rapid
Surface fragment cover <=3"	13–27%
Surface fragment cover >3"	0–25%
Available water capacity (Depth not specified)	1.1–4.7 in
Calcium carbonate equivalent (Depth not specified)	0–5%
Clay content (Depth not specified)	6–20%
Electrical conductivity (Depth not specified)	0 mmhos/cm
Sodium adsorption ratio (Depth not specified)	0
Soil reaction (1:1 water) (Depth not specified)	5.6–7.8
Subsurface fragment volume <=3" (Depth not specified)	13–41%
Subsurface fragment volume >3" (Depth not specified)	0–22%

Ecological dynamics

The Streambank site is dominated by willow and grasses/grass-like. Willows are able to withstand flooding because of flexible stems and they are generally tolerant of saturated soil. A artificial lowering of the water table could alter the vegetation by increasing plant species that are more tolerant to dry soil conditions.

State and transition model

Ecosystem states

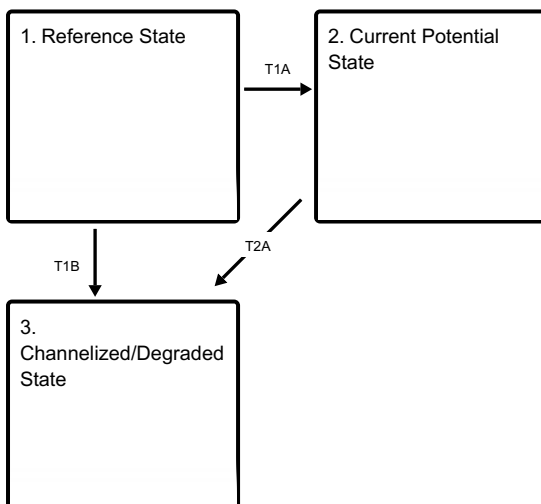

State 1 submodel, plant communities

1.1.
Willows/graminoids

State 2 submodel, plant communities

2.1. Native and Non-
native
shrubs/graminoids

State 3 submodel, plant communities

3.1. Degraded
Community Phase

State 1 Reference State

The Reference State has one main community phase. The community phase is dominated by willow and sedges.

Community 1.1 Willows/graminoids

The primary plant community in the Reference State is dominated by willows and sedges.

State 2 Current Potential State

The Current Potential State is similar to the Reference State with the exception of non-native plants. Non-native thistles may invade this site.

Community 2.1 Native and Non-native shrubs/graminoids

Tamarisk may also occur and take the place of native willows. Kentucky bluegrass is effective at invading wet to semiwet sites and may dominate the understory.

State 3 Channelized/Degraded State

The Channelized/Degraded state is characterized by an adjacent stream that has been channelized. Most seasonal floodwaters remain in the channel and do not inundate the flood plain. This may reduce soil moisture on the site allowing species that are more tolerant to dry conditions to establish.

Community 3.1 Degraded Community Phase

The plant community at this phase may look like a drier ecological site with sagebrush or rabbitbrush. This phase

may also be converted to a agricultural field or urban development.

Transition T1A

State 1 to 2

Introduction of non-native species.

Transition T1B

State 1 to 3

Reduced soil moisture and altered hydrology of the site. Urbanization and agriculture uses may be present.

Transition T2A

State 2 to 3

Reduced soil moisture and altered hydrology of the site. Urbanization and agriculture uses may be present.

Additional community tables

Contributors

P.Novak

Approval

Kendra Moseley, 4/10/2024

Rangeland health reference sheet

Interpreting Indicators of Rangeland Health is a qualitative assessment protocol used to determine ecosystem condition based on benchmark characteristics described in the Reference Sheet. A suite of 17 (or more) indicators are typically considered in an assessment. The ecological site(s) representative of an assessment location must be known prior to applying the protocol and must be verified based on soils and climate. Current plant community cannot be used to identify the ecological site.

Author(s)/participant(s)	
Contact for lead author	
Date	04/25/2024
Approved by	Kendra Moseley
Approval date	
Composition (Indicators 10 and 12) based on	Annual Production

Indicators

1. **Number and extent of rills:**

2. **Presence of water flow patterns:**

3. **Number and height of erosional pedestals or terracettes:**

4. **Bare ground from Ecological Site Description or other studies (rock, litter, lichen, moss, plant canopy are not bare ground):**
-
5. **Number of gullies and erosion associated with gullies:**
-
6. **Extent of wind scoured, blowouts and/or depositional areas:**
-
7. **Amount of litter movement (describe size and distance expected to travel):**
-
8. **Soil surface (top few mm) resistance to erosion (stability values are averages - most sites will show a range of values):**
-
9. **Soil surface structure and SOM content (include type of structure and A-horizon color and thickness):**
-
10. **Effect of community phase composition (relative proportion of different functional groups) and spatial distribution on infiltration and runoff:**
-
11. **Presence and thickness of compaction layer (usually none; describe soil profile features which may be mistaken for compaction on this site):**
-
12. **Functional/Structural Groups (list in order of descending dominance by above-ground annual-production or live foliar cover using symbols: >>, >, = to indicate much greater than, greater than, and equal to):**
- Dominant:
- Sub-dominant:
- Other:
- Additional:
-
13. **Amount of plant mortality and decadence (include which functional groups are expected to show mortality or decadence):**
-
14. **Average percent litter cover (%) and depth (in):**
-
15. **Expected annual annual-production (this is TOTAL above-ground annual-production, not just forage annual-production):**

16. **Potential invasive (including noxious) species (native and non-native). List species which BOTH characterize degraded states and have the potential to become a dominant or co-dominant species on the ecological site if their future establishment and growth is not actively controlled by management interventions. Species that become dominant for only one to several years (e.g., short-term response to drought or wildfire) are not invasive plants. Note that unlike other indicators, we are describing what is NOT expected in the reference state for the ecological site:**

17. **Perennial plant reproductive capability:**
