

Ecological site R026XY001NV MOIST FLOODPLAIN

Last updated: 4/10/2024
Accessed: 04/25/2024

General information

Provisional. A provisional ecological site description has undergone quality control and quality assurance review. It contains a working state and transition model and enough information to identify the ecological site.

MLRA notes

Major Land Resource Area (MLRA): 026X–Carson Basin and Mountains

The area lies within western Nevada and eastern California, with about 69 percent being within Nevada, and 31 percent being within California. Almost all this area is in the Great Basin Section of the Basin and Range Province of the Intermontane Plateaus. Isolated north-south trending mountain ranges are separated by aggraded desert plains. The mountains are uplifted fault blocks with steep side slopes. Most of the valleys are drained by three major rivers flowing east across this MLRA. A narrow strip along the western border of the area is in the Sierra Nevada Section of the Cascade-Sierra Mountains Province of the Pacific Mountain System. The Sierra Nevada Mountains are primarily a large fault block that has been uplifted with a dominant tilt to the west. This structure leaves an impressive wall of mountains directly west of this area. This helps create a rain shadow affect to MLRA 26. Parts of this eastern face, but mostly just the foothills, mark the western boundary of this area. Elevations range from about 3,806 feet (1,160 meters) on the west shore of Pyramid Lake to 11,653 feet (3,552 meters) on the summit of Mount Patterson in the Sweetwater Mountains.

Valley areas are dominantly composed of Quaternary alluvial deposits with Quaternary playa or alluvial flat deposits often occupying the lowest valley bottoms in the internally drained valleys, and river deposited alluvium being dominant in externally drained valleys. Hills and mountains are dominantly Tertiary andesitic flows, breccias, ash flow tuffs, rhyolite tuffs or granodioritic rocks. Quaternary basalt flows are present in lesser amounts, and Jurassic and Triassic limestone and shale, and Precambrian limestone and dolomite are also present in very limited amounts. Also of limited extent are glacial till deposits along the east flank of the Sierra Nevada Mountains, the result of alpine glaciation.

The average annual precipitation in this area is 5 to 36 inches (125 to 915 millimeters), increasing with elevation. Most of the rainfall occurs as high-intensity, convective storms in spring and autumn. Precipitation is mostly snow in winter. Summers are dry. The average annual temperature is 37 to 54 degrees F (3 to 12 degrees C). The freeze-free period averages 115 days and ranges from 40 to 195 days, decreasing in length with elevation.

The dominant soil orders in this MLRA are Aridisols and Mollisols. The soils in the area dominantly have a mesic soil temperature regime, an aridic or xeric soil moisture regime, and mixed or smectitic mineralogy. They generally are well drained, are clayey or loamy and commonly skeletal, and are very shallow to moderately deep.

This area supports shrub-grass vegetation characterized by big sagebrush. Low sagebrush and Lahontan sagebrush occur on some soils. Antelope bitterbrush, squirreltail, desert needlegrass, Thurber needlegrass, and Indian ricegrass are important associated plants. Green ephedra, Sandberg bluegrass, Anderson peachbrush, and several forb species also are common. Juniper-pinyon woodland is typical on mountain slopes. Jeffrey pine, lodgepole pine, white fir, and manzanita grow on the highest mountain slopes. Shadscale is the typical plant in the drier parts of the area. Sedges, rushes, and moisture-loving grasses grow on the wettest parts of the wet flood plains and terraces. Basin wildrye, alkali sacaton, saltgrass, buffaloberry, black greasewood, and rubber rabbitbrush grow on the drier sites that have a high concentration of salts.

Some of the major wildlife species in this area are mule deer, coyote, beaver, muskrat, jackrabbit, cottontail, raptors, pheasant, chukar, blue grouse, mountain quail, and mourning dove. The species of fish in the area include trout and catfish. The Lahontan cutthroat trout in the Truckee River is a threatened and endangered species.

LRU notes

The Semiarid Fans and Basins LRU includes basins, alluvial fans and adjacent hill slopes immediately east of the Sierra Nevada mountain range and are affected by its climate or have its granitic substrate. Elevations range from 1355 to 1920 meters and slopes range from 0 to 30 percent, with a median value of 6 percent. Frost free days range from 121 to 170.

Ecological site concept

The Moist Floodplain site is found on flood plains and stream terraces at slopes less than 2 percent. The soil is deep and somewhat poorly to poorly drained. The soil texture is various from clay loam to sandy loam. The site is rarely flooded for very brief periods. The water table is between 30 and 60 inches deep. The dominant plants are beardless wildrye (*Leymus triticoides*) and basin wildrye (*Leymus cinereus*).

Associated sites

R026XY004NV	SALINE BOTTOM
R026XY012NV	DRY FLOODPLAIN 8-10 P.Z.
R026XY013NV	SODIC FLOODPLAIN

Similar sites

F026XY059NV	Sandy Flood Plain 8-10 P.Z POFR2 dominant plant; Fremont cottonwood woodland.
R026XY012NV	DRY FLOODPLAIN 8-10 P.Z. LECI4 dominant grass; less productive site
R026XY003NV	WET MEADOW 10-14 P.Z. PONE3 dominant grass

Table 1. Dominant plant species

Tree	Not specified
Shrub	Not specified
Herbaceous	(1) <i>Leymus triticoides</i> (2) <i>Leymus cinereus</i>

Physiographic features

This site occurs on broad axial-stream floodplains along major stream drainages. Slopes are generally from 0 to less than 2 percent. Elevations are 4000 to 5000 feet.

Table 2. Representative physiographic features

Landforms	(1) Flood plain (2) Stream terrace
Flooding duration	Very brief (4 to 48 hours)
Flooding frequency	Rare
Elevation	4,000–5,000 ft
Slope	0–2%
Water table depth	30–60 in

Aspect	Aspect is not a significant factor
--------	------------------------------------

Climatic features

The climate associated with this site is semiarid, characterized by cool, moist winters and warm, dry summers. Average annual precipitation is 8 to 12 inches. mean annual air temperature is 49 to 50 degrees F. The average growing season is about 100 to 120 days.

Nevada's climate is predominantly arid, with large daily ranges of temperature, infrequent severe storms, heavy snowfall in the higher mountains, and great location variations with elevation. Three basic geographical factors largely influence Nevada's climate: continentality, latitude, and elevation. Continentality is the most important factor. The strong continental effect is expressed in the form of both dryness and large temperature variations. Nevada lies on the eastern, lee side of the Sierra Nevada Range, a massive mountain barrier that markedly influences the climate of the State. The prevailing winds are from the west, and as the warm moist air from the Pacific Ocean ascend the western slopes of the Sierra Range, the air cools, condensation occurs and most of the moisture falls as precipitation. As the air descends the eastern slope, it is warmed by compression, and very little precipitation occurs. The effects of this mountain barrier are felt not only in the West but throughout the state, with the result that the lowlands of Nevada are largely desert or steppes. The temperature regime is also affected by the blocking of the inland-moving maritime air. Nevada sheltered from maritime winds, has a continental climate with well-developed seasons and the terrain responds quickly to changes in solar heating.

Nevada lies within the mid-latitude belt of prevailing westerly winds which occur most of the year. These winds bring frequent changes in weather during the late fall, winter and spring months, when most of the precipitation occurs. To the south of the mid-latitude westerlies, lies a zone of high pressure in subtropical latitudes, with a center over the Pacific Ocean. In the summer, this high-pressure belt shifts northward over the latitudes of Nevada, blocking storms from the ocean. The resulting weather is mostly clear and dry during the summer and early fall, with scattered thundershowers. The eastern portion of the state receives significant summer thunderstorms generated from monsoonal moisture pushed up from the Gulf of California, known as the North American monsoon. The monsoon system peaks in August and by October the monsoon high over the Western U.S. begins to weaken and the precipitation retreats southward towards the tropics (NOAA 2004).

Table 3. Representative climatic features

Frost-free period (characteristic range)	
Freeze-free period (characteristic range)	
Precipitation total (characteristic range)	8-12 in
Frost-free period (average)	110 days
Freeze-free period (average)	
Precipitation total (average)	10 in

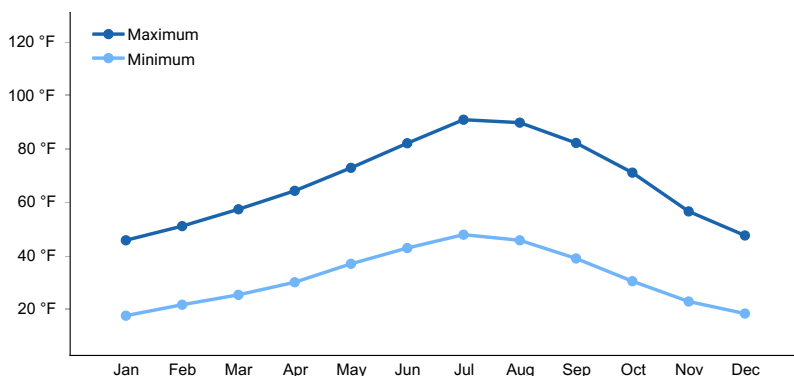

Figure 1. Monthly average minimum and maximum temperature

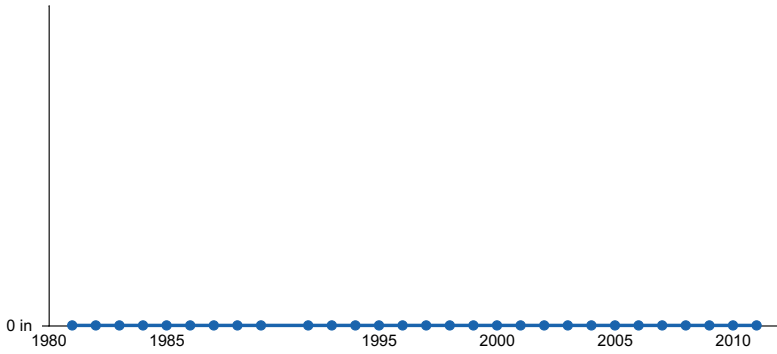

Figure 2. Annual precipitation pattern

Influencing water features

This site occurs on broad axial-stream floodplains along major stream drainages and receives additional moisture during spring runoff and convective summer storms.

Soil features

The soils associated with this site are deep to very deep, poorly drained and have a high available water capacity. The water table ranges at or near the soil surface during the spring runoff period but may drop below 60 inches during the late summer when stream flow is at its lowest. The soils are subject to flooding on an average of at least one year in three and often receive deposition of new soil materials. Because of frequent overland flow, these soils are highly susceptible to gullyng.

Table 4. Representative soil features

Parent material	(1) Alluvium
Surface texture	(1) Sandy loam (2) Loam (3) Clay loam (4) Silt loam
Drainage class	Somewhat poorly drained to poorly drained
Permeability class	Slow to moderately rapid
Surface fragment cover <=3"	0–9%
Surface fragment cover >3"	0–2%
Available water capacity (Depth not specified)	3.1–7.7 in
Calcium carbonate equivalent (Depth not specified)	0–5%
Electrical conductivity (Depth not specified)	0–16 mmhos/cm
Sodium adsorption ratio (Depth not specified)	0–12
Soil reaction (1:1 water) (Depth not specified)	6.1–8.4
Subsurface fragment volume <=3" (Depth not specified)	0–19%
Subsurface fragment volume >3" (Depth not specified)	0–10%

Ecological dynamics

As ecological condition declines, willows, rushes, and wild iris become more dominant. Plant species adapted to moist and moderately saline affected soils of this site thrive. In some locations the soils have been partially drained by stream entrenchment and xerophytic plant species invade the site.

Fire Ecology:

Grassland vegetation types experienced both short fire intervals of less than 35 years as well as intervals ranging from 35 to 100 years, depending on climate and ignition sources. Creeping wildrye is top-killed by fire. Creeping wildrye is generally tolerant of fire but may be damaged by early season fire combined with dry soil conditions. Basin wildrye is top-killed by fire. Older basin wildrye plants with large proportions of dead material within the perennial crown can be expected to show higher mortality due to fire than younger plants having little debris. Basin wildrye is generally tolerant of fire but may be damaged by early season fire combined with dry soil conditions. Nevada bluegrass is generally unharmed by fire. It produces little litter, and its small bunch size and sparse litter reduces the amount of heat transferred to perennating buds in the soil.

State and transition model

Ecosystem states

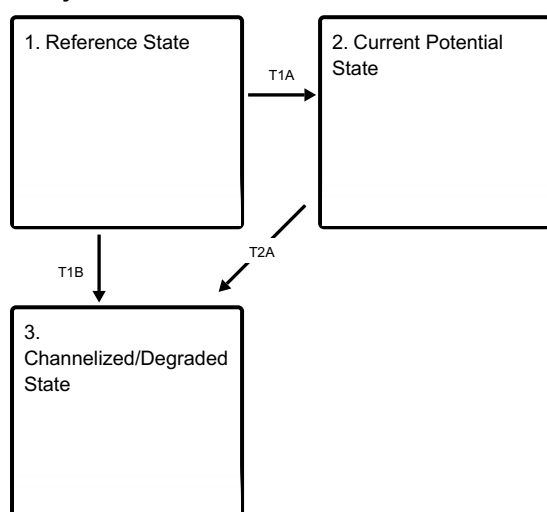

State 1 submodel, plant communities

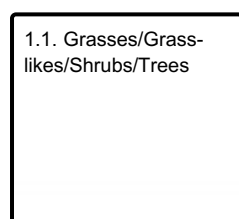

State 2 submodel, plant communities

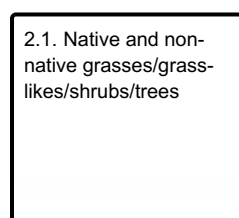

State 3 submodel, plant communities

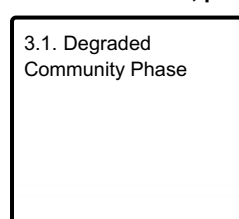

State 1 Reference State

The Reference State concept has one identified community phase influenced by time since disturbance (flooding, fire, etc.). The primary plants in this site are grasses and grasslikes, however there is a small component of shrubs and trees. Cottonwood seeds will be left behind after a seasonal flood event. The cottonwood seedlings will germinate if the soil conditions are right (moist and bare). These seedlings, if left undisturbed, will mature to trees that can be sparse on this site. Understory plants, like rhizomatous willow and graminoids are less influenced by seasonal flooding and may remain intact after seasonal flooding.

Community 1.1 Grasses/Grass-likes/Shrubs/Trees

The reference plant community is dominated by creeping wildrye and basin wildrye. Potential vegetative composition is about 80% grasses and grass-like plants, 10% forbs and 10% shrubs and trees.

Table 5. Annual production by plant type

Plant Type	Low (Lb/Acre)	Representative Value (Lb/Acre)	High (Lb/Acre)
Grass/Grasslike	3040	3600	4800
Forb	380	450	600
Shrub/Vine	266	315	420
Tree	114	135	180
Total	3800	4500	6000

State 2 Current Potential State

The Current Potential State occurs after non-native plant species introduction. The species can range from trees, shrubs, to herbaceous. Russian olive, tamarisk, Kentucky bluegrass, and thistles are common non-native plants that can establish on this site.

Community 2.1 Native and non-native grasses/grass-likes/shrubs/trees

Non-native trees, like Russian olive are present and may dominate the tree canopy. Tamarisk may also occur and take the place of native willows. Kentucky bluegrass is effective at invading wet to semiwet sites and may dominate the understory.

State 3 Channelized/Degraded State

The Channelized/Degraded state is characterized by a adjacent stream that has been channelized. Most seasonal floodwaters remain the in channel and do not inundate the flood plain. This reduces cottonwood recruitment and may reduce soil moisture on the site allowing species that are more tolerant to dry conditions to establish.

Community 3.1 Degraded Community Phase

The plant community at this phase may look like a drier ecological site with sagebrush or rabbitbrush. This phase may also be converted to a agricultural field or urban development.

Transition T1A State 1 to 2

Introduction of non-native plants.

Transition T1B

State 1 to 3

Channelization of the adjacent stream channel. Or artificial lowering of the water table. Or a combination of these two disturbances.

Transition T2A

State 2 to 3

Reduced soil moisture and altered hydrology of the site. Urbanization and agriculture uses may be present.

Additional community tables

Table 6. Community 1.1 plant community composition

Group	Common Name	Symbol	Scientific Name	Annual Production (Lb/Acre)	Foliar Cover (%)
Grass/Grasslike					
1	Primary Perennial Grasses			1890–2760	
	beardless wildrye	LETR5	<i>Leymus triticoides</i>	1575–2025	–
	basin wildrye	LECI4	<i>Leymus cinereus</i>	225–375	–
2	Secondary Perennial Grasses			225–450	
	sedge	CAREX	<i>Carex</i>	23–90	–
	saltgrass	DISP	<i>Distichlis spicata</i>	23–90	–
	thickspike wheatgrass	ELLA3	<i>Elymus lanceolatus</i>	23–90	–
	western wheatgrass	PASM	<i>Pascopyrum smithii</i>	23–90	–
Forb					
3	Perennial			225–675	
	saltgrass	DISP	<i>Distichlis spicata</i>	23–90	–
	yarrow	ACHIL	<i>Achillea</i>	23–90	–
	Rocky Mountain iris	IRMI	<i>Iris missouriensis</i>	23–90	–
	cinquefoil	POTEN	<i>Potentilla</i>	23–90	–
	ragwort	SENEC	<i>Senecio</i>	23–90	–
	clover	TRIFO	<i>Trifolium</i>	23–90	–
Shrub/Vine					
4	Secondary Shrubs			90–450	
	basin big sagebrush	ARTRT	<i>Artemisia tridentata ssp. tridentata</i>	23–135	–
	rubber rabbitbrush	ERNAN5	<i>Ericameria nauseosa ssp. nauseosa var. nauseosa</i>	23–135	–
	currant	RIBES	<i>Ribes</i>	23–135	–
	Woods' rose	ROWO	<i>Rosa woodsii</i>	23–135	–
	willow	SALIX	<i>Salix</i>	23–135	–
	greasewood	SAVE4	<i>Sarcobatus vermiculatus</i>	23–135	–
	silver buffaloberry	SHAR	<i>Shepherdia argentea</i>	23–135	–
	sedge	CAREX	<i>Carex</i>	23–90	–
Tree					
5	Deciduous			23–135	
	Fremont cottonwood	POFR2	<i>Populus fremontii</i>	23–135	–

Animal community

Livestock Interpretations:

This site is suited for livestock grazing. Grazing management should be keyed to creeping wildrye, basin wildrye and perennial grass production. Creeping wildrye can be used for forage and is very palatable to all livestock. Once established it is very rhizomatous and maintains stands for many years. The early growth and abundant production of basin wildrye make it a valuable source of forage for livestock. It is important forage for cattle and is readily grazed by cattle and horses in early spring and fall. Though coarse-textured during the winter, basin wildrye may be utilized more frequently by livestock when snow has covered low shrubs and other grasses. Bluegrass is a widespread forage grass. It is one of the earliest grasses in the spring and is sought by domestic livestock and

several wildlife species. Nevada bluegrass is a palatable species, but its production is closely tied to weather conditions. It produces little forage in drought years, making it a less dependable food source than other perennial bunchgrasses.

Stocking rates vary over time depending upon season of use, climate variations, site, and previous and current management goals. A safe starting stocking rate is an estimated stocking rate that is fine tuned by the client by adaptive management through the year and from year to year.

Wildlife interpretations:

Creeping wildrye and basin wildrye are important forage species for several wildlife species. They provide winter forage for mule deer, though use is often low compared to other native grasses. Creeping wildrye and basin wildrye provide summer forage for black-tailed jackrabbits. Because creeping wildrye and basin wildrye remains green throughout early summer, it remains available for small mammal forage for longer time than other grasses. They provide important forage especially in the winter when snow has covered low shrubs and other grasses. Nevada bluegrass is also an important forage species for several wildlife species.

Recreational uses

Aesthetic value is derived from the diverse floral and faunal composition and the colorful flowering of wild flowers and shrubs during the spring and early summer. This site offers rewarding opportunities to photographers and for nature study. This site is used for camping and hiking and has potential for upland and big game hunting.

Other products

Basin wildrye was used as bedding for various Native American ceremonies, providing a cool place for dancers to stand.

Type locality

Location 1: Douglas County, NV	
Township/Range/Section	T13N R19E S2
General legal description	Approximately 1½ miles northeast of Genoa, Carson River floodplain, Douglas County, Nevada.

Other references

Fire Effects Information System (Online; <http://www.fs.fed.us/database/feis/plants/>).

USDA-NRCS Plants Database (Online; <http://www.plants.usda.gov>).

Contributors

DK/FR/GKB

Approval

Kendra Moseley, 4/10/2024

Rangeland health reference sheet

Interpreting Indicators of Rangeland Health is a qualitative assessment protocol used to determine ecosystem condition based on benchmark characteristics described in the Reference Sheet. A suite of 17 (or more) indicators are typically considered in an assessment. The ecological site(s) representative of an assessment location must be known prior to applying the protocol and must be verified based on soils and climate. Current plant community

cannot be used to identify the ecological site.

Author(s)/participant(s)	
Contact for lead author	
Date	04/25/2024
Approved by	Kendra Moseley
Approval date	
Composition (Indicators 10 and 12) based on	Annual Production

Indicators

1. **Number and extent of rills:**

2. **Presence of water flow patterns:**

3. **Number and height of erosional pedestals or terracettes:**

4. **Bare ground from Ecological Site Description or other studies (rock, litter, lichen, moss, plant canopy are not bare ground):**

5. **Number of gullies and erosion associated with gullies:**

6. **Extent of wind scoured, blowouts and/or depositional areas:**

7. **Amount of litter movement (describe size and distance expected to travel):**

8. **Soil surface (top few mm) resistance to erosion (stability values are averages - most sites will show a range of values):**

9. **Soil surface structure and SOM content (include type of structure and A-horizon color and thickness):**

10. **Effect of community phase composition (relative proportion of different functional groups) and spatial distribution on infiltration and runoff:**

11. **Presence and thickness of compaction layer (usually none; describe soil profile features which may be mistaken for compaction on this site):**

-
12. **Functional/Structural Groups (list in order of descending dominance by above-ground annual-production or live foliar cover using symbols: >>, >, = to indicate much greater than, greater than, and equal to):**

Dominant:

Sub-dominant:

Other:

Additional:

13. **Amount of plant mortality and decadence (include which functional groups are expected to show mortality or decadence):**
-

14. **Average percent litter cover (%) and depth (in):**
-

15. **Expected annual annual-production (this is TOTAL above-ground annual-production, not just forage annual-production):**
-

16. **Potential invasive (including noxious) species (native and non-native). List species which BOTH characterize degraded states and have the potential to become a dominant or co-dominant species on the ecological site if their future establishment and growth is not actively controlled by management interventions. Species that become dominant for only one to several years (e.g., short-term response to drought or wildfire) are not invasive plants. Note that unlike other indicators, we are describing what is NOT expected in the reference state for the ecological site:**
-

17. **Perennial plant reproductive capability:**
-