

Ecological site R035XA128AZ Tephra Uplands, Loamy 10-14" p.z

Accessed: 04/28/2024

General information

Provisional. A provisional ecological site description has undergone quality control and quality assurance review. It contains a working state and transition model and enough information to identify the ecological site.

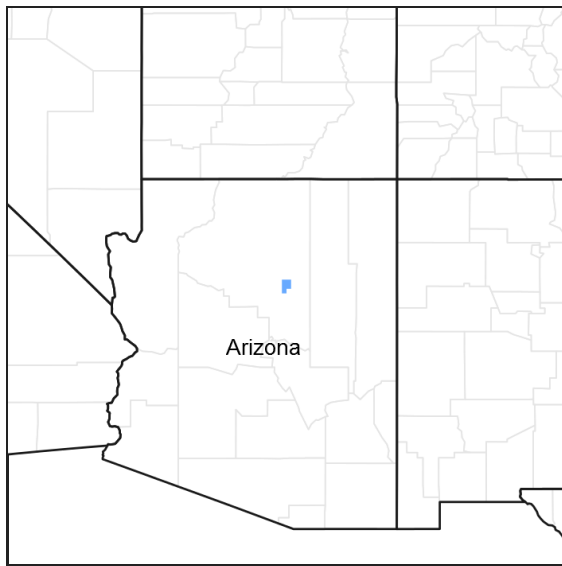

Figure 1. Mapped extent

Areas shown in blue indicate the maximum mapped extent of this ecological site. Other ecological sites likely occur within the highlighted areas. It is also possible for this ecological site to occur outside of highlighted areas if detailed soil survey has not been completed or recently updated.

MLRA notes

Major Land Resource Area (MLRA): 035X–Colorado Plateau

This ecological site occurs in Common Resource Area 35.1 - the Colorado Plateau Mixed Grass Plains

Elevations range from 4800 to 6300 feet and precipitation averages 10 to 14 inches per year. Vegetation includes *Stipa* species, Indian ricegrass, galleta, and blue grama, fourwing saltbush, winterfat, and cliffrose. The soil temperature regime is mesic and the soil moisture regime is ustic aridic. This unit occurs within the Colorado Plateau Physiographic Province and is characterized by a sequence of flat to gently dipping sedimentary rocks eroded into plateaus, valleys and deep canyons. Sedimentary rock classes dominate the plateau with volcanic fields occurring for the most part near its margin.

Table 1. Dominant plant species

Tree	Not specified
Shrub	(1) <i>Atriplex canescens</i>
Herbaceous	(1) <i>Bouteloua eriopoda</i> (2) <i>Bouteloua gracilis</i>

Physiographic features

This site occurs on uplands of fan remnants, structural benches, footslopes of hills and cinder cones. This site does not suffer from excessive runoff or benefit from run-in moisture. Moisture infiltration is good because of the coarse textures of the soil. Some available moisture is lost on steeper slopes. Slopes generally range from 0-15% with occasional steeper slopes.

Table 2. Representative physiographic features

Landforms	(1) Fan remnant (2) Hill (3) Cinder cone
Flooding frequency	None
Ponding frequency	None
Elevation	1,463–1,920 m
Slope	0–15%
Aspect	Aspect is not a significant factor

Climatic features

50-60% of moisture falls as rain Jul-Sep and is the most effective moisture for plant growth. The remaining moisture comes as snow during the winter.

Mean temperature for the hottest month (Jul) is 72 F; for the coldest month (Jan) is 32 F. Extreme temperatures of 105 F and -28F have been recorded. Long periods with little or no effective moisture are relatively common.

Cool season plants begin growth in early spring and mature early summer. Warm season plants take advantage of summer rains and are growing and nutritious Jul-Sep.

Table 3. Representative climatic features

Frost-free period (average)	160 days
Freeze-free period (average)	180 days
Precipitation total (average)	330 mm

Influencing water features

Soil features

The soils on this site are shallow over cinders or cemented cinders. The surface horizons, about 2 to 10 inches thick, generally have textures of gravelly to very gravelly loam. The subsurface horizons have textures of gravelly to very gravelly loams over a cinders or cemented cinders. Permeability is moderate to moderately slow but the soils on level slopes can absorb and hold all the moisture the climate can supply. On steeper slopes some moisture is lost in runoff. The soil reaction ranges from slightly to moderately alkaline (pH 7.4-8.4).

Typical taxonomic units include:

Little Colorado River SSA707 MU's-Wilaha 65, Wukoki 67 & 68, Wupatki 68;

Table 4. Representative soil features

Parent material	(1) Cinders–pyroclastic rock
Surface texture	(1) Gravelly loam (2) Very gravelly loam
Family particle size	(1) Loamy

Drainage class	Well drained to somewhat excessively drained
Permeability class	Moderately slow to moderately rapid
Soil depth	25–51 cm
Surface fragment cover <=3"	15–55%
Surface fragment cover >3"	0–25%
Available water capacity (0-101.6cm)	3.3–8.89 cm
Calcium carbonate equivalent (0-101.6cm)	0–25%
Electrical conductivity (0-101.6cm)	0–2 mmhos/cm
Sodium adsorption ratio (0-101.6cm)	0–2
Soil reaction (1:1 water) (0-101.6cm)	7.4–8.4

Ecological dynamics

The plant communities found on an ecological site are naturally variable. Composition and production will vary with yearly conditions, location, aspect, and the natural variability of the soils. The historical climax plant community represents the natural potential plant communities found on relict or relatively undisturbed sites. Other plant communities described here represent plant communities that are known to occur when the site is disturbed by factors such as grazing, fire, or drought.

Production data provided in this site description is standardized to air-dry weight at the end of the summer growing season. The plant communities described in this site description are based on near normal rainfall years.

NRCS uses a Similarity Index to compare existing plant communities to the plant communities described here. Similarity Index is determined by comparing the production and composition of a plant community to the production and composition of a plant community described in this site description. To determine Similarity Index, compare the production (air-dry weight) of each species to that shown in the plant community description. For each species, count no more than the maximum amount shown for the species, and for each group, count no more than the maximum shown for the group. Divide the resulting total by the total normal year production shown in the plant community description. If rainfall has been significantly above or below normal, use the total production shown for above or below normal years. If field data is not collected at the end of the summer growing season, then the field data must be corrected to the end of the year production before comparing it to the site description. The growth curve can be used as a guide for estimating production at the end of the summer growing season.

The State and Transition model shows the most common occurring plant communities likely to be encountered on this ecological site. This model may not show every possible plant community, but only those that are most prevalent and observed through field inventory. As more data is collected and research is available, these plant communities may be revised, removed, and even added to reflect the ecological dynamics of this site.

State and transition model

**35.1AZ Cinder Uplands 10-14" p.z.
(R035XA128AZ)**

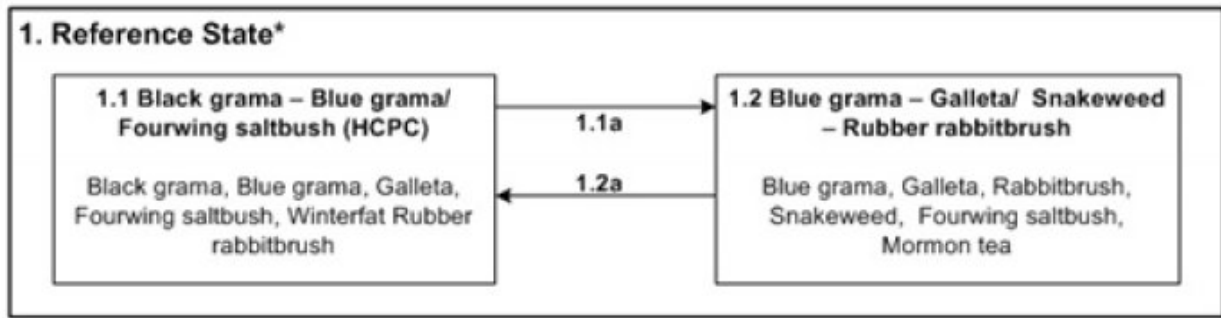

*introduced annuals may or not be present in minor amounts

Figure 4. State and Transition Model - R035XA128AZ

**State 1
Reference State**

The reference state and the reference (climax) plant community has been determined by study of relict areas or areas protected from excessive disturbances. Trends in plant communities unmanaged grazed areas to managed grazed areas, seasonal use pastures and historical accounts have also been used. The reference state is characterized as a grassland community of mid and short grasses with a moderate percentage of shrubs and half shrubs.

**Community 1.1
Black grama - Blue grama/ Fourwing saltbush**



Figure 5. Cinder Hills 10-14" p.z.

This plant community is made up primarily of mid and short grasses with a relatively small percentage of shrubs, half shrubs and forbs. The plant community may have an occasional juniper at higher elevations. There is a mixture of both cool and warm season grasses. Plants most likely to invade or increase on this site when it deteriorates are broom snakeweed, wooly groundsel, annuals, cacti, juniper and rabbitbrush. Unmanaged grazing during the winter and spring periods will decrease the cool season grasses, which are replaced by warm season, lower forage value grasses and shrubs. In this plant community there may be a trace of non-native annuals present. They do not change the sites ecological processes in these minor amounts

Table 5. Annual production by plant type

Plant Type	Low (Kg/Hectare)	Representative Value (Kg/Hectare)	High (Kg/Hectare)
Grass/Grasslike	275	460	633
Shrub/Vine	45	73	101
Forb	17	22	28
Tree	–	–	11
Total	337	555	773

Community 1.2

Blue grama - Galleta/ Snakeweed - Rubber rabbitbrush

Plant community is made up primarily of mid and short grasses and scattered large and half shrubs with a relatively small percentage of forbs and trees. It has an open overstory of scattered junipers. There is a mixture of both cool and warm season grasses. Plants most likely to invade or increase on this site when it deteriorates are broom snakeweed, wooly groundsel, annuals, cacti, juniper and rabbitbrush. Unmanaged grazing during the winter and spring periods will decrease the cool season grasses, which are replaced by warm season, lower forage value grasses and shrubs. The plant community composition for this site is 45-65% grasses, 30-40% shrubs, 1-10% forbs and 1-5% trees. In this plant community there may be trace amounts of non-native annuals present. They do not change the sites ecological processes in these minor amounts

Pathway 1.1a

Community 1.1 to 1.2

Drought, Unmanaged grazing

Pathway 1.2a

Community 1.2 to 1.1

Prescribed grazing, favorable climate or periods of good precipitation

Additional community tables

Table 6. Community 1.1 plant community composition

Group	Common Name	Symbol	Scientific Name	Annual Production (Kg/Hectare)	Foliar Cover (%)
Grass/Grasslike					
1	Dominant Grasses			336–527	
	black grama	BOER4	<i>Bouteloua eriopoda</i>	112–224	–
	blue grama	BOGR2	<i>Bouteloua gracilis</i>	56–168	–
	James' galleta	PLJA	<i>Pleuraphis jamesii</i>	28–84	–
	sideoats grama	BOCU	<i>Bouteloua curtipendula</i>	28–84	–
2	Other Grasses			56–135	
	needle and thread	HECO26	<i>Hesperostipa comata</i>	17–39	–
	common wolfstail	LYPH	<i>Lycurus phleoides</i>	17–39	–
	squirreltail	ELELE	<i>Elymus elymoides ssp. elymoides</i>	6–28	–
	muttongrass	POFE	<i>Poa fendleriana</i>	6–28	–
	spike dropseed	SPCO4	<i>Sporobolus contractus</i>	6–28	–
	sand dropseed	SPCR	<i>Sporobolus cryptandrus</i>	6–28	–
	Grass, perennial	2GP	<i>Grass, perennial</i>	0–17	–
	threeawn	ARIST	<i>Aristida</i>	0–17	–
	vine mesquite	PAOB	<i>Panicum obtusum</i>	0–17	–
	Grass, annual	2GA	<i>Grass, annual</i>	0–11	–
Forb					
3	Forbs			6–28	
	Forb, annual	2FA	<i>Forb, annual</i>	0–11	–
	Forb, perennial	2FP	<i>Forb, perennial</i>	0–11	–
	globemallow	SPHAE	<i>Sphaeralcea</i>	0–6	–
Shrub/Vine					
4	Dominant Shrubs			28–84	
	fourwing saltbush	ATCA2	<i>Atriplex canescens</i>	28–56	–
	jointfir	EPHED	<i>Ephedra</i>	22–45	–
	winterfat	KRLA2	<i>Krascheninnikovia lanata</i>	22–45	–
5	Other Shrubs			28–84	
	prairie sagewort	ARFR4	<i>Artemisia frigida</i>	0–28	–
	Greene's rabbitbrush	CHGR6	<i>Chrysothamnus greenei</i>	0–28	–
	yellow rabbitbrush	CHV18	<i>Chrysothamnus viscidiflorus</i>	0–28	–
	rubber rabbitbrush	ERNA10	<i>Ericameria nauseosa</i>	0–28	–
	woolly groundsel	PACA15	<i>Packera cana</i>	0–17	–
	yerba de pasmo	BAPT	<i>Baccharis pteronioides</i>	0–17	–
	pricklypear	OPUNT	<i>Opuntia</i>	0–11	–
	Whipple cholla	CYWH	<i>Cylindropuntia whipplei</i>	0–11	–
Tree					
6	Trees			0–11	
	oneseed juniper	JUMO	<i>Juniperus monosperma</i>	0–11	–

Table 7. Community 1.2 plant community composition

Group	Common Name	Symbol	Scientific Name	Annual Production (Kg/Hectare)	Foliar Cover (%)
-------	-------------	--------	-----------------	--------------------------------	------------------

Animal community

This site is suitable for grazing at any time of the year by all livestock types. Planned grazing systems can be readily adapted for use on this site. Mechanical improvement practices, such as chaining, pitting or seeding would not be adaptable to this site; however, this site will respond relatively fast to good management.

The nearly level to steeper topography adds habitat diversity to the site. Juniper stands have developed in many areas as a result of fire exclusion and overgrazing. These tree forms increase diversity of wildlife.

Recreational uses

Winters are cold, but summers are quite warm and attractive for recreational use.

Uses include cross country travel, photography, wildlife observation, hunting, and rock collecting.

Wood products

Even though Juniper can develop on this site as a result of fire exclusion and overgrazing there is not enough production for commercial firewood harvesting or posts.

Type locality

Location 1: Apache County, AZ	
General legal description	Near old highway 666, seven miles northwest of Springerville, AZ

Other references

Updates and revisions for this ESD were conducted as part of a 2007-2012 Interagency Technical Assistance Agreement between the Bureau of Indian Affairs–Navajo Region and the NRCS-Arizona.

This site was originally included with the Cinder Hills (R035XA102AZ), but was separated to capture the lower slopes with more soil development, the shallow slopes overlying cinders or duripan of lime-cemented cinders with higher vegetation production.

Contributors

Ken Gishi

Kenneth Gishi

Rangeland health reference sheet

Interpreting Indicators of Rangeland Health is a qualitative assessment protocol used to determine ecosystem condition based on benchmark characteristics described in the Reference Sheet. A suite of 17 (or more) indicators are typically considered in an assessment. The ecological site(s) representative of an assessment location must be known prior to applying the protocol and must be verified based on soils and climate. Current plant community cannot be used to identify the ecological site.

Author(s)/participant(s)	Kenneth Gishi
Contact for lead author	State Rangeland Management Specialist, NRCS-Arizona State Office, Phoenix, AZ
Date	09/13/2012
Approved by	Byron Lambeth
Approval date	
Composition (Indicators 10 and 12) based on	Annual Production

Indicators

1. **Number and extent of rills:** None. Due to high content of gravels and cobbles along with loamy textures no rills would be expected.

2. **Presence of water flow patterns:** None Expected.

3. **Number and height of erosional pedestals or terracettes:** None expected.

4. **Bare ground from Ecological Site Description or other studies (rock, litter, lichen, moss, plant canopy are not bare ground):** Bare ground ranges from 15-30%.

5. **Number of gullies and erosion associated with gullies:** None.

6. **Extent of wind scoured, blowouts and/or depositional areas:** None.

7. **Amount of litter movement (describe size and distance expected to travel):** None.

8. **Soil surface (top few mm) resistance to erosion (stability values are averages - most sites will show a range of values):** High amounts of vegetation production (mostly grasses) along with high surface rock content yields moderate to high resistance to water erosion and wind resistance. Expected stability values range from 1-2. The site is fairly stable due to the cindery surface.

9. **Soil surface structure and SOM content (include type of structure and A-horizon color and thickness):** Soil structure is typically weak very fine granular structure or weak thick platy structure. Surface thickness ranges from 2-10 inches thick. Colors are typically brown (10YR 5/3) or grayish brown (10YR 5/2). See the local soil survey report for specific soils information.

10. **Effect of community phase composition (relative proportion of different functional groups) and spatial distribution on infiltration and runoff:** There is a fairly even distribution of grasses with scattered shrubs and a small amount of forbs. This plant community on this site is moderately effective at capturing and storing moisture.

11. **Presence and thickness of compaction layer (usually none; describe soil profile features which may be mistaken for compaction on this site):** None. These soils are gravelly to very gravelly with cinders.

12. **Functional/Structural Groups (list in order of descending dominance by above-ground annual-production or live**

foliar cover using symbols: >>, >, = to indicate much greater than, greater than, and equal to):

Dominant: Warm season colonizing grasses > Warm season bunch grasses >

Sub-dominant: Cool season bunch grasses > Large shrubs > Half shrubs >

Other: Forbs > Trees

Additional:

13. **Amount of plant mortality and decadence (include which functional groups are expected to show mortality or decadence):** In a normal year up to 10% of grasses and shrubs die off. During and after drought years there can be from 10 to 20% die off of shrubs and grasses. Severe winter droughts affect shrubs, trees and cool season grasses the most. Severe summer droughts affect the warm season grasses the most.
-

14. **Average percent litter cover (%) and depth (in):**
-

15. **Expected annual annual-production (this is TOTAL above-ground annual-production, not just forage annual-production):** Average annual production on this site is expected to be 450 to 550 lbs/ac. in a year of average annual precipitation.
-

16. **Potential invasive (including noxious) species (native and non-native). List species which BOTH characterize degraded states and have the potential to become a dominant or co-dominant species on the ecological site if their future establishment and growth is not actively controlled by management interventions. Species that become dominant for only one to several years (e.g., short-term response to drought or wildfire) are not invasive plants. Note that unlike other indicators, we are describing what is NOT expected in the reference state for the ecological site:** Snakeweed, rabbitbrush, junipers, wooly groundsel, and cacti all have the potential to increase and invade the site with disturbance. Non-native annuals, such as cheatgrass and Russian thistle also have the potentials to invade the site with or without disturbance.
-

17. **Perennial plant reproductive capability:** All plants native to this site are adapted to the climate and are capable of producing seeds, stolons and rhizomes except during the most severe droughts.
-