

## Ecological site F043BP702WY Shallow Cool Woodland Group

Last updated: 3/01/2024  
Accessed: 05/17/2024

---

### General information

**Provisional.** A provisional ecological site description has undergone quality control and quality assurance review. It contains a working state and transition model and enough information to identify the ecological site.

### MLRA notes

Major Land Resource Area (MLRA): 043B–Central Rocky Mountains

Major Land Resource Area (MLRA): 043B–Central Rocky Mountains

043B – Central Rocky Mountains – This MLRA is extensive including Montana, Idaho, Wyoming and a small portion in Utah. This MLRA consists of the major chains of Mountain Ranges with the corresponding valleys. Cartographic standards limited the ability to capture the foothills as a separate MLRA, so revisions of the MLRA boundaries in 2006 led to the inclusion of the foothills with the mountains for much of Wyoming.

Further information regarding MLRAs, refer to: United States Department of Agriculture, Natural Resources Conservation Service. 2006. Land Resource Regions and Major Land Resource Areas of the United States, the Caribbean, and the Pacific Basin. U.S. Department of Agriculture Handbook 296.  
Available electronically at: [http://www.nrcs.usda.gov/wps/portal/nrcs/detail/soils/ref/?cid=nrcs142p2\\_053624#handbook](http://www.nrcs.usda.gov/wps/portal/nrcs/detail/soils/ref/?cid=nrcs142p2_053624#handbook).

### LRU notes

LRU P: PES (Provisional Ecological Site or Group - PEG) A PROVISIONAL ECOLOGICAL SITE is a conceptual grouping of soil map unit components within a Major Land Resource Area (MLRA) based on the similarities in response to management. Although there may be wide variability in the productivity of the soils grouped into a Provisional Site, the soil vegetation interactions as expressed in the State and Transition Model are similar and the management actions required to achieve objectives, whether maintaining the existing ecological state or managing for an alternative state, are similar. Provisional Sites are likely to be refined into more precise concept during the process of meeting the APPROVED ECOLOGICAL SITE DESCRIPTION criteria.

This PROVISIONAL ECOLOGICAL SITE has been developed to meet the standards established in the National Ecological Site Handbook. The information associated with this ecological site does not meet the Approved Ecological Site Description Standard, but it has been through a Quality Control and Quality Assurance processes to assure consistency and completeness. Further investigations, reviews and correlations are necessary before it becomes an Approved Ecological Site Description.

### Classification relationships

Other Classifications:

PSME/PHMA habitat type (Steele Et.Al. 1983)  
PSME/ACGL habitat type (Steele Et.Al. 1983)  
PSME/SYAL habitat type (Steele Et.Al. 1983)  
PSME/CARU habitat type (Steele Et.Al. 1983)  
PSME/BERE habitat type (Steele Et.Al. 1983)  
PSME/SPBE habitat type (Steele Et.Al. 1983)

PSME/JUCOD habitat type (Steele Et.Al. 1983)  
 PSME/ARCO habitat type (Steele Et.Al. 1983)  
 PIFL2/JUCOD habitat type (Steele Et.Al. 1983)

## Ecological site concept

- Site does not receive any additional water
- Soils are
  - o Generally not saline or saline-sodic
  - o Shallow
  - o Typically less than 5% stone and boulder on surface (<15%)
  - o Soil surface texture ranges from sandy loam to clay loam in surface mineral 4"

## Associated sites

F043BP710WY	<b>Upland Cool Woodland Group</b> Upland Cool Woodland can be found in slightly concave or deeper soils below or around the Shallow Cool Woodlands.
F043BP707WY	<b>Subirrigated Cool Woodland Group</b> Subirrigated Cool Woodlands will occur below or at the foot of the Shallow Cool Woodlands, generally associated with the valley floor or low-lying flatter positions with the slopes coming up from the floor being the Shallow Cool Woodlands.
F043BP708WY	<b>Upland Aspen Woodland Group</b> Upland Aspen Woodland can be intermixed with the Shallow Cool Woodland, especially in snow melt pockets or seeps occurring near or below rock outcrops, with the Shallow Cool woodlands occurring on the upper edges or sides associated with the rock outcrops.

## Similar sites

R043BY260WY	<b>Shallow Igneous Foothills and Mountains West</b> Shallow Igneous 15-19
R043BY360WY	<b>Shallow Igneous (Swlg) 15-19" Foothills and Mountains East Precipitation Zone</b> Shallow Igneous 15-19
R043BY262WY	<b>Shallow Loamy Foothills and Mountains West</b> Shallow Loamy 15-19
F043BP704WY	<b>Shallow Warm Woodland Group</b> Shallow Warm Woodlands have the same general site concept, except occurs on lower elevations or western aspect slopes across the Mountains. The warmer temperature affects both the tree species as well as the understory species.
R043BY362WY	<b>Shallow Loamy (SwLy) 15-19" Foothills and Mountains East Precipitation Zone</b> Shallow Loamy 15-19

Table 1. Dominant plant species

Tree	(1) <i>Pseudotsuga menziesii</i> (2) <i>Pinus contorta</i>
Shrub	(1) <i>Symphoricarpos occidentalis</i> (2) <i>Spiraea betulifolia</i>
Herbaceous	(1) <i>Calamagrostis rubescens</i> (2) <i>Carex geyeri</i>

## Physiographic features

This site occurs on most slopes and along ridge tops. Rock outcrops are common in association with this ecological site.

**Table 2. Representative physiographic features**

Geomorphic position, mountains	(1) Mountainflank (2) Free face (3) Mountaintop
Landforms	(1) Mountains > Mountain slope (2) Mountains > Moraine (3) Mountains > Ridge
Runoff class	Low to very high
Elevation	1,829–3,048 m
Slope	15–80%
Aspect	Aspect is not a significant factor

## Climatic features

Annual precipitation ranges from 15-19 inches per year. June is generally the wettest month. July, August, and September are somewhat less with daily amounts rarely exceeding one inch. Wide fluctuations may occur in yearly precipitation and result in more dry years than those with more than normal precipitation.

Temperatures show a wide range between summer and winter and between daily maximums and minimums. This is predominantly due to the high elevation and dry air, which permits rapid incoming and outgoing radiation. Cold air outbreaks in winter move rapidly from northwest to southeast and account for extreme minimum temperatures.

Snowfall is quite heavy in the area. Annual snowfall averages about 150 inches. Extreme storms may occur during the winter, but most severely affect ranch operations during late winter and spring.

Prevailing winds are from the southwest, because of the varied topography, the wind will vary considerably for different parts of the area. The wind is usually much lighter at the lower elevations and in the valleys as compared with the higher terrain. Occasional storms, however, can bring brief periods of high winds with gusts exceeding 50 mph. Growth of native cool season plants begins about May 15 and continues to about September 15.

The following information is from the "Jackson", "Cooke City 2W", and "Burgess Junction" climate stations, at the lower end of this precipitation zone. Climate Data is limited and is being extrapolated from the nearest stations.

**Table 3. Representative climatic features**

Frost-free period (characteristic range)	4-7 days
Freeze-free period (characteristic range)	42-52 days
Precipitation total (characteristic range)	457-584 mm
Frost-free period (actual range)	3-7 days
Freeze-free period (actual range)	39-54 days
Precipitation total (actual range)	432-610 mm
Frost-free period (average)	5 days
Freeze-free period (average)	47 days
Precipitation total (average)	533 mm

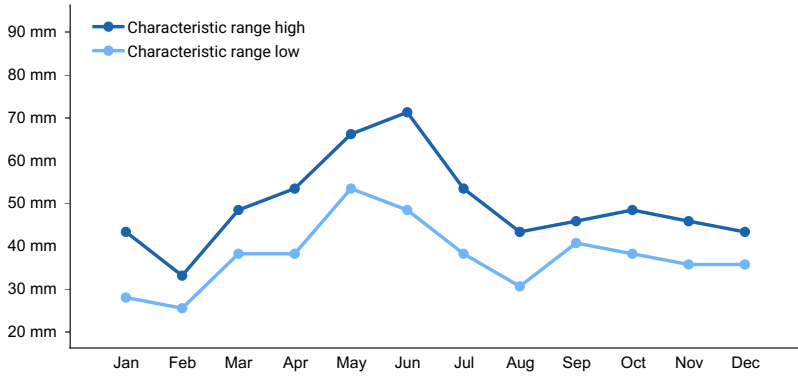

**Figure 1. Monthly precipitation range**

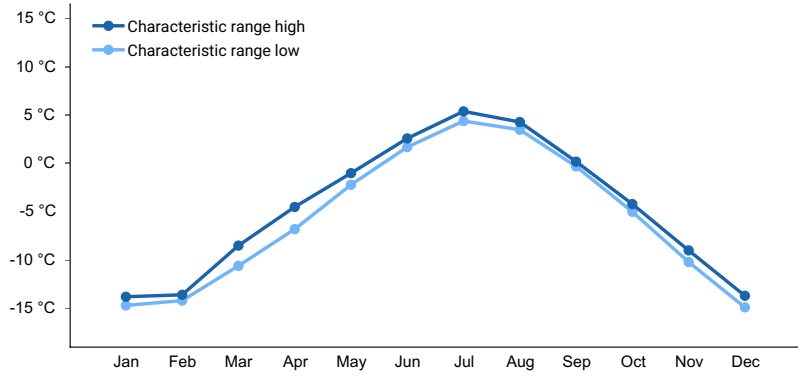

**Figure 2. Monthly minimum temperature range**

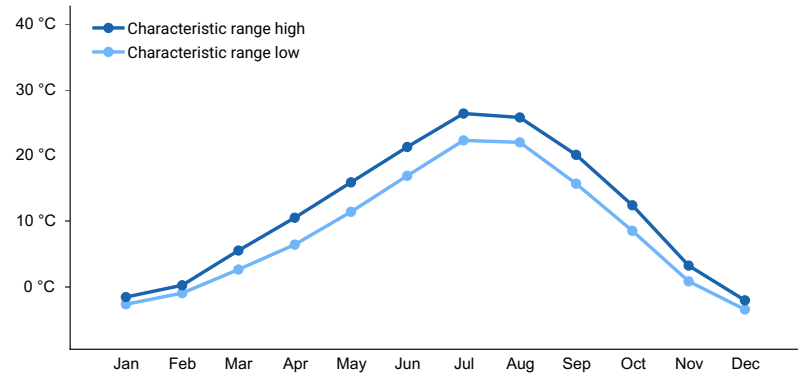

**Figure 3. Monthly maximum temperature range**

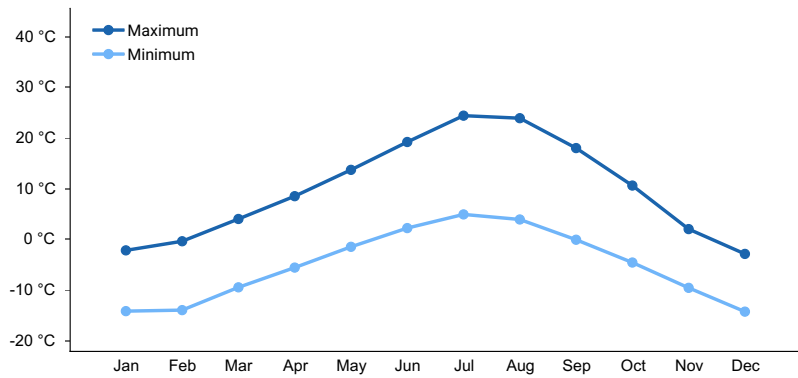

**Figure 4. Monthly average minimum and maximum temperature**

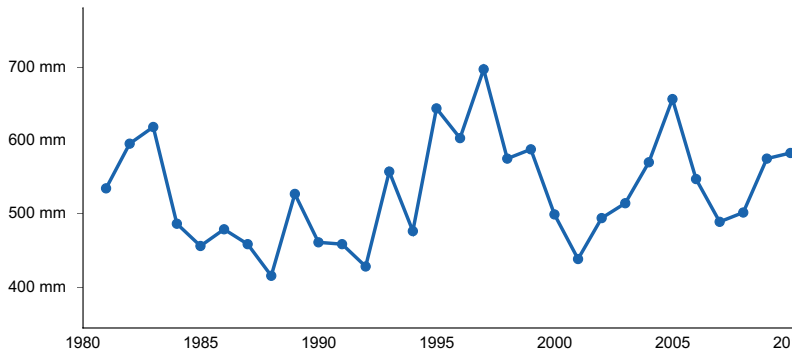

**Figure 5. Annual precipitation pattern**

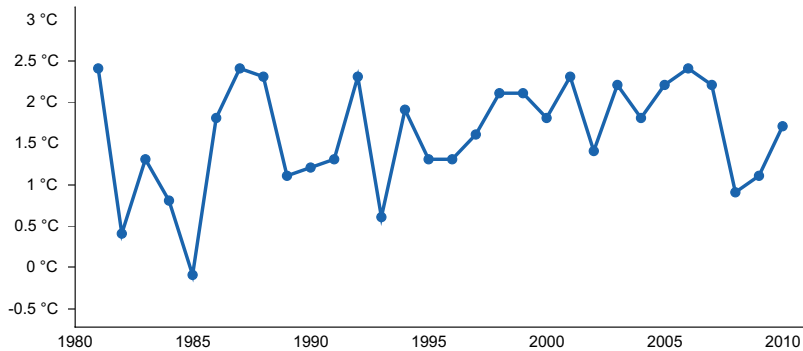

**Figure 6. Annual average temperature pattern**

### **Climate stations used**

- (1) COOKE CITY 2 W [USC00241995], Gardiner, MT
- (2) JACKSON [USC00484910], Jackson, WY
- (3) BURGESS JUNCTION [USC00481220], Dayton, WY

### **Influencing water features**

This site is not associated with any type of surface water feature. Snow drift impact is moderate.

### **Soil features**

The soils associated with this site were derived from calcareous sandstone, limestone, quartzite-sandstone mixes, or granitics. These soils are generally less than 20" in depth and virtually impermeable to plant roots. Pockets of deep soil may occur in this site and are moderately acidic. The bedrock will include igneous, metamorphic and sedimentary material. The soil characteristic having the most influence on the plant community is the shallow depth and slope. Soil temperature regime is found on the upper extent of frigid and the lower extent of cryic; while, soil moisture regime is typic ustic to typic udic.



Figure 7. Hand excavated pit in the Shallow Cool Woodland ecological site.

Table 4. Representative soil features

Parent material	(1) Colluvium–limestone and dolomite (2) Residuum–granite and gneiss (3) Slope alluvium–sedimentary rock (4) Quartzite
Surface texture	(1) Stony, bouldery sandy loam (2) Clay loam (3) Loam (4) Silty clay loam
Drainage class	Well drained
Permeability class	Slow to rapid
Depth to restrictive layer	25–51 cm
Soil depth	25–51 cm
Surface fragment cover <=3"	0–20%
Surface fragment cover >3"	5–15%
Calcium carbonate equivalent (Depth not specified)	0–5%
Electrical conductivity (Depth not specified)	0–2 mmhos/cm
Soil reaction (1:1 water) (Depth not specified)	5.4–7
Subsurface fragment volume <=3" (Depth not specified)	0–20%
Subsurface fragment volume >3" (Depth not specified)	0–15%

## Ecological dynamics

### State and transition model

#### Ecosystem states

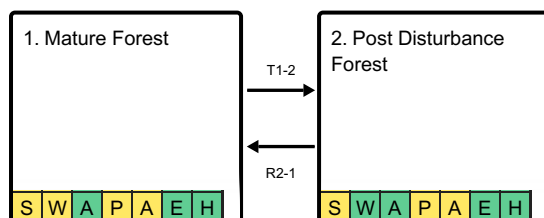

**T1-2** - Post disturbance impacts reducing the Douglas-fir stands, including increased fire frequency, disease, insect pestilence, and clear-cut logging.

**R2-1** - Time, management of desired species, and possibly the use of nursery stock or seeding will allow the timber stand to recover.

### State 1 submodel, plant communities

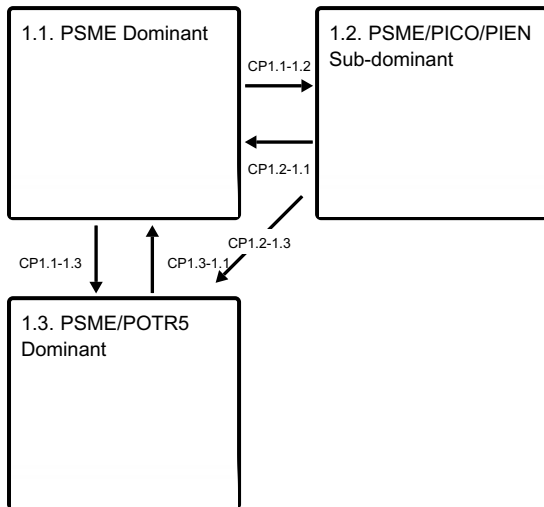

**CP1.1-1.2** - Natural processes of aging, fire, insects and disease will allow the movement to a mixed timber stand. Selective timber harvest and controlled burns will also assist in this process.

**CP1.1-1.3** - Natural or applied techniques to open the canopy of Douglas-fir can encourage quaking aspen when the hydrologic conditions and nursery stalk is present.

**CP1.2-1.1** - Lack of timber management, with fire or other techniques, will lead to a mature nearly monoculture stand of Douglas-fir.

**CP1.2-1.3** - Removal or opening of current conifer stands encourages the re-establishment of quaking aspen.

**CP1.3-1.1** - Lack of fire and the impacts of disease and insect damage to quaking aspen lead to the loss of aspen and the increase of conifers.

### State 2 submodel, plant communities

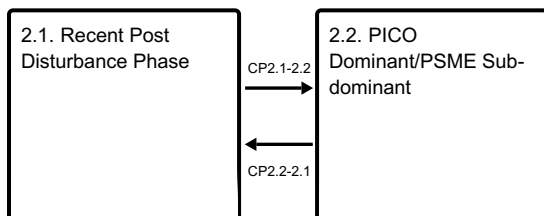

**CP2.1-2.2** - Natural succession or with stand management and plantings, mixed conifer growth will become the dominant cover on this site.

**CP2.2-2.1** - Fire or other disturbances that remove the woody canopy allowing the under-story to become dominant on the site.

## State 1 Mature Forest

Natural succession of the forest stand is driven by fire or other tools to maintain canopy and stand health. The successional forest communities that are identified generally include three main community phases. The post fire shrub community is not captured in this state, but is captured in the post disturbance state.

**Characteristics and indicators.** The dominance of Douglas-fir in the Mature phase is followed by an opening of the canopy by fire allowing a sub-dominance of either lodge pole pine (or limber pine in lower elevations) or of quacking aspen. A variety of under story compositions can be described for this state.

**Resilience management.** Fire is a natural component for stand replacement and tree health. The frequency and intensity of these fires are the driving factors in the transition within and out of this state.

### Dominant plant species

- Douglas-fir (*Pseudotsuga menziesii*), tree

- lodgepole pine (*Pinus contorta*), tree
- limber pine (*Pinus flexilis*), tree
- mountain mahogany (*Cercocarpus*), shrub
- chokecherry (*Prunus virginiana*), shrub
- common snowberry (*Symphoricarpos albus*), shrub
- bluebunch wheatgrass (*Pseudoroegneria spicata*), grass
- Geyer's sedge (*Carex geyeri*), grass
- spike fescue (*Leucopoa kingii*), grass
- arnica (*Arnica*), other herbaceous
- western meadow-rue (*Thalictrum occidentale*), other herbaceous
- feathery false lily of the valley (*Maianthemum racemosum*), other herbaceous

### Dominant resource concerns

- Sheet and rill erosion
- Classic gully erosion
- Organic matter depletion
- Wildfire hazard from biomass accumulation
- Terrestrial habitat for wildlife and invertebrates

## Community 1.1 PSME Dominant



Figure 8. Mature Douglas-fir community on a cool shallow site.

Mature stands of primarily Douglas-fir with limited under story growth are the dominant canopy for this community phase. The main under story species are arnica, ninebark, snowberry and a variety of other tall shrubs. This community phase is a distinct old growth timber stand with a significant duff layer and woody litter.

**Resilience management.** Fire plays a major role in the function and cycle of this plant community.

### Dominant plant species

- Douglas-fir (*Pseudotsuga menziesii*), tree
- mallow ninebark (*Physocarpus malvaceus*), shrub
- western snowberry (*Symphoricarpos occidentalis*), shrub
- Geyer's sedge (*Carex geyeri*), grass
- spike fescue (*Leucopoa kingii*), grass
- bluebunch wheatgrass (*Pseudoroegneria spicata*), grass
- arnica (*Arnica*), other herbaceous
- western meadow-rue (*Thalictrum occidentale*), other herbaceous

## Community 1.2 PSME/PICO/PIEN Sub-dominant





Figure 9. Lodge pole pine, Englemann spruce and Douglas-fir community impacted by beetle kill.

Following fire, the regeneration of less dominant species, such as lodge pole pine and Englemann spruce increase initially until Douglas-fir increase in density. With a diversity of woody species, and before the canopy closes, a mixture of grasses and forbs will be prominent in the under story.

**Resilience management.** Maturing of the woody canopy is a natural progression of this community. Fire plays a role in maintaining an open canopy or a more diverse composition.

### Dominant plant species

- Douglas-fir (*Pseudotsuga menziesii*), tree
- lodgepole pine (*Pinus contorta*), tree
- Englemann spruce (*Picea engelmannii*), tree
- twinflower (*Linnaea borealis*), shrub
- russet buffaloberry (*Shepherdia canadensis*), shrub
- common juniper (*Juniperus communis*), shrub
- pinegrass (*Calamagrostis rubescens*), grass
- spike fescue (*Leucopoa kingii*), grass
- Geyer's sedge (*Carex geyeri*), grass
- feathery false lily of the valley (*Maianthemum racemosum*), other herbaceous
- Nuttall's violet (*Viola nuttallii*), other herbaceous
- western meadow-rue (*Thalictrum occidentale*), other herbaceous

### Community 1.3 PSME/POTR5 Dominant



Figure 10. Pockets of Aspen intermixed with Douglas-fir.

In select positions within the landscape of Douglas-fir, quaking aspen will maintain a strong community. Sedges, reed grass, fescues and other herbaceous species will be prominent in this community.

**Resilience management.** Encroachment of spruce and fir will crowd the aspen community, shading the aspen out over time with the lack of fire. Disease and insects are also detrimental to the aspen stands, and fire helps to maintain the health of the stand with time.

**Dominant plant species**

- quaking aspen (*Populus tremuloides*), tree
- Douglas-fir (*Pseudotsuga menziesii*), tree
- chokecherry (*Prunus virginiana*), shrub
- russet buffaloberry (*Shepherdia canadensis*), shrub
- snowbrush ceanothus (*Ceanothus velutinus*), shrub
- pinegrass (*Calamagrostis rubescens*), grass
- Idaho fescue (*Festuca idahoensis*), grass
- bluebunch wheatgrass (*Pseudoroegneria spicata*), grass
- arnica (*Arnica*), other herbaceous
- feathery false lily of the valley (*Maianthemum racemosum*), other herbaceous
- Nuttall's violet (*Viola nuttallii*), other herbaceous

**Pathway CP1.1-1.2  
Community 1.1 to 1.2**

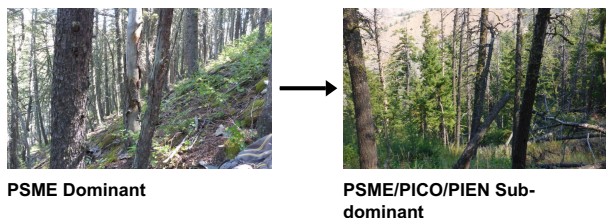

Replacement fires, controlled or wild, to reduce the canopy of the Douglas-fir and to encourage the lodge pole pine and englemann's spruce transitions this timber stand to Community 1.2. The under story responds to the increased light exposure, and micro-climate shifts. The use of selective timber harvest methods as well as natural insect and disease cycles will help this to occur naturally. Aging of timber stands will also see this natural transition.

**Pathway CP1.1-1.3  
Community 1.1 to 1.3**

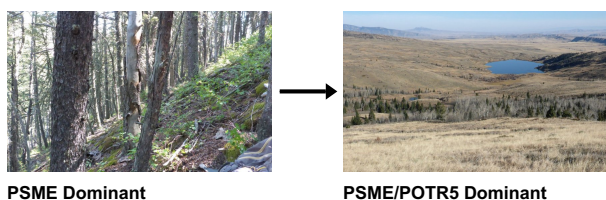

Replacement fire to reduce the fuel loads, open the canopy and improve water movement through the canopy to the soil encourages the growth and establishment of quaking aspen stands. Continued control of the overstory of conifers helps to maintain this mixed timber stand.

**Context dependence.** The needed increase in hydrology with seeps or snow catch as well as the nursery source is needed to encourage this transition in the timber stand.

**Conservation practices**

Patch-burning to enhance wildlife habitat
Wildlife corridors
Forest stand improvement pre-treating vegetation and fuels
Forest Stand Improvement, Prescribed burning
Forest Stand Improvement to Reduce Wildfire Risk

## Pathway CP1.2-1.1 Community 1.2 to 1.1

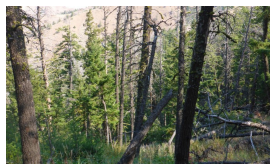

PSME/PICO/PIEN Sub-dominant

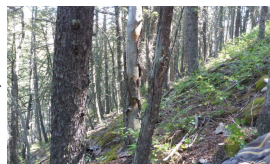

PSME Dominant

With the reduced fire frequency, lack of timber management and no major impacts to the timber stand, Douglas-fir will increase in density, crowding out lodge pole pine and englemann's spruce, leaving a mature and dense stand of Douglas-fir over time.

## Pathway CP1.2-1.3 Community 1.2 to 1.3

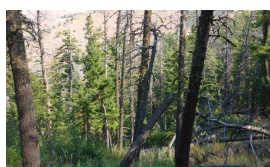

PSME/PICO/PIEN Sub-dominant



PSME/POTR5 Dominant

Fire frequency for stand replacement opens the canopy, recovering hydrology in select areas encouraging the re-establishment of quaking aspen where nursery sources are available. Timber management with selective harvest or falling timber to create protective niches for aspen to establish or techniques to encourage this transition.

**Context dependence.** The necessary seeps or snow pack driven hydrology is necessary as well as nursery stock to allow this transition to occur.

### Conservation practices

Upland Wildlife Habitat Management
Forest Stand Improvement
Forest stand improvement for habitat and soil quality
Forest stand improvement pre-treating vegetation and fuels
Forest Stand Improvement, Prescribed burning
Forest Stand Improvement to Reduce Wildfire Risk

## Pathway CP1.3-1.1 Community 1.3 to 1.1



PSME/POTR5 Dominant

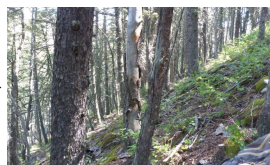

PSME Dominant

The lack of fire, timber management or other disturbances will allow Douglas-fir to crowd out quaking aspen and the stand will transition to a mature Douglas-fir dominant stand. Disease and insect impacts are significant risks to quaking aspen and the lack of rejuvenation can accelerate the loss of aspen and increase in conifers.

## State 2 Post Disturbance Forest



Stand replacement initiated by a disturbance, specifically logging or fire with additional disturbance post-fire, produces a secondary successional forest community that can broadly be described in two main community phases.

**Characteristics and indicators.** The dominance of the community by shrubs with a scattering (less than 10% cover) of young saplings, generally of lodge pole pine is the initial community phase. As the phase matures, the forest community shifts to a lodge pole pine forest stand with a minor component of Douglas-fir.

**Resilience management.** Fire is a natural component for stand replacement and tree health; however, disturbance following fire creates the transitions found in this state. Fire will continue to be a tool for forest health management within this stand.

### Dominant plant species

- lodgepole pine (*Pinus contorta*), tree
- Engelmann spruce (*Picea engelmannii*), tree
- Douglas-fir (*Pseudotsuga menziesii*), tree
- russet buffaloberry (*Shepherdia canadensis*), shrub
- spirea (*Spiraea*), shrub
- snowbrush ceanothus (*Ceanothus velutinus*), shrub
- pinegrass (*Calamagrostis rubescens*), grass
- spike fescue (*Leucopoa kingii*), grass
- Idaho fescue (*Festuca idahoensis*), grass
- arnica (*Arnica*), other herbaceous
- fireweed (*Chamerion angustifolium*), other herbaceous
- feathery false lily of the valley (*Maianthemum racemosum*), other herbaceous

### Dominant resource concerns

- Sheet and rill erosion
- Classic gully erosion
- Organic matter depletion
- Aggregate instability
- Wildfire hazard from biomass accumulation
- Terrestrial habitat for wildlife and invertebrates

## Community 2.1

### Recent Post Disturbance Phase



Figure 11. Post disturbance herbaceous under story. This site was logged and then was impacted by wildfire.

Following a quick fire return interval, significant insect or disease impacts, or other major disturbances, saplings of lodge pole pines will be the main woody species to re-establish within a prominent under story of tall shrubs and herbaceous species within this community phase.

**Resilience management.** Lodge pole pine will increase and become dense mature stands in the absence of fire or if no further disturbance occurs on this site.

### **Dominant plant species**

- lodgepole pine (*Pinus contorta*), tree
- snowbrush ceanothus (*Ceanothus velutinus*), shrub
- western snowberry (*Symphoricarpos occidentalis*), shrub
- chokecherry (*Prunus virginiana*), shrub
- pinegrass (*Calamagrostis rubescens*), grass
- spike fescue (*Leucopoa kingii*), grass
- Idaho fescue (*Festuca idahoensis*), grass
- fireweed (*Chamerion angustifolium*), other herbaceous
- arnica (*Arnica*), other herbaceous

## **Community 2.2**

### **PICO Dominant/PSME Sub-dominant**

As natural succession of the post disturbance community occurs, lodge pole pine increase in canopy and a minor cover of Douglas-fir can be found commonly intermixed. Herbaceous species and some shrubs will decrease with the increasing woody canopy.

**Resilience management.** Fire is the key to maintaining a healthy mixed stand of trees. In the absence of fire, or significant disease and insect pressure, the woody species will become the dominant cover and will restrict the under story significantly.

### **Dominant plant species**

- lodgepole pine (*Pinus contorta*), tree
- Douglas-fir (*Pseudotsuga menziesii*), tree
- creeping barberry (*Mahonia repens*), shrub
- common juniper (*Juniperus communis*), shrub
- western snowberry (*Symphoricarpos occidentalis*), shrub
- pinegrass (*Calamagrostis rubescens*), grass
- Geyer's sedge (*Carex geyeri*), grass
- arnica (*Arnica*), other herbaceous
- western meadow-rue (*Thalictrum occidentale*), other herbaceous

## **Pathway CP2.1-2.2**

### **Community 2.1 to 2.2**

Natural succession following fire especially, but with any disturbance, these forest stands will increase with conifer saplings with time. Management to reduce decimation of select conifer species may be needed in heavy corridor or use areas. Control of the frequency of fires may be necessary in areas where there is still a heavy fuels load to allow establishment of the woody species.

### **Conservation practices**

Critical Area Planting
Upland Wildlife Habitat Management
Early Successional Habitat Development/Management
Fuel Break
Prescribed Forestry
Patch-burning to enhance wildlife habitat
Forest stand improvement for habitat and soil quality
Forest stand improvement pre-treating vegetation and fuels

Forest Stand Improvement, Prescribed burning
Forest Stand Improvement to Reduce Wildfire Risk
Forest stand improvement pre-treating vegetation and fuels preceding a prescribed fire

**Pathway CP2.2-2.1**  
**Community 2.2 to 2.1**

Natural fire cycles, controlled burns, clear-cutting or selective timber harvest can open up areas that allow the under story vegetation to become dominant on the site. Insect, disease and other major shifts in the natural cycle or man induced disturbances can also reduce the canopy transitioning the site to a herbaceous dominated phase.

**Transition T1-2**  
**State 1 to 2**

Disturbances such as increased frequency of fires, insect pestilence, disease, and clear-cut logging reduces Douglas-fir and increases the density of other tree species, including lodge pole pine and englemann's spruce.

**Constraints to recovery.** The lack of recovery time between disturbances, loss of viable seed sources, and climatic impacts, recovery of this site is impacted.

**Context dependence.** This ecological site description is a broad description and the variability of species shifts from the northern to southern extent and eastern compared to western continental divide shifts in species will vary the exact plant species, wildlife impacts, and climatic variables influencing this site.

**Restoration pathway R2-1**  
**State 2 to 1**

With fire management, insect and disease control, and revegetation practices following timber harvest or other cover disturbances provides the recovery time to allow the natural processes to occur. In the instance that the needed seed sources or nursery crops are not present, planting or seeding may be required.

**Conservation practices**

Prescribed Burning
Critical Area Planting
Fuel Break
Patch-burning to enhance wildlife habitat
Forest stand improvement for habitat and soil quality
Wildlife corridors
Forest stand improvement pre-treating vegetation and fuels
Forest Stand Improvement, Prescribed burning

**Additional community tables**

**Animal community**

This site and plant community complex has minimal livestock grazing capacity in the old stand forests. In new growth or following logging or fire, this site may offer some livestock forage. This site is common habitat for elk, mule deer, bear, wolf, mountain lion, and a variety of other wildlife.

**Hydrological functions**

Water is the principal factor limiting forage production on this site. This site is highly variable and is dominated by soils in hydrologic group B and C, with localized areas in hydrologic group D. Infiltration ranges from slow to very

rapid. Runoff potential for this site varies from moderate to high depending on soil hydrologic group, depth and degree of bedrock fracturing, slope, and ground cover (refer to Part 630, NRCS National Engineering Handbook for detailed hydrology information.)

Rills and gullies may be present, but should be small. Water flow patterns should be barely distinguishable. Pedestals are only slightly present in association with bunchgrasses such as bluebunch wheatgrass. Litter typically falls in place, and signs of movement are not common. Chemical and physical crusts are rare to non-existent. Cryptogamic crusts are present, but only cover 1-2% of the soil surface.

## **Recreational uses**

This site provides hunting opportunities for large ungulates and fur bearing species. Limited for upland game bird species.

Hiking is limited by density of tree stands and slope of site.

## **Wood products**

Timber harvest for lumber and firewood, as well as post and pole cuttings are common on this forest type. Christmas tree harvest occurs on lower extents of this forest type.

## **Other products**

Berry harvest from understory species as well as medicinal plants can be found within this ecological site. Fungi (mushroom) harvest can also occur in specific locations.

## **Inventory data references**

Information presented here has been derived from NRCS data and other inventory data.

Field observations from range trained personnel were also used. Those involved in developing this site include: Bill Christensen, Range Management Specialist, NRCS; Karen Clause, Range Management Specialist, NRCS; and Everet Bainter, Range Management Specialist, NRCS. Other sources used as references include: USDA NRCS Water and Climate Center, USDA NRCS National Range and Pasture Handbook, and USDA NRCS Soil Surveys from various counties.

## **Other references**

Steele, Robert; Cooper, Stephen V.; Ondov, David M.; Roberts, David W.; Pfister, Robert D. 1983. Forest Habitat Types of Eastern Idaho-Western Wyoming. General Technical Report INT-144. Ogden, UT: U.S. Department of Agriculture, Forest Service, Intermountain Forest and Range Experiment Station. 122 p.

## **Contributors**

Karen Clause, Multi-County Rangeland Management Specialist, USDA-NRCS

Marji Patz, Ecological Site Specialist, USDA-NRCS

Bryan Christensen, Ecological Site Specialist, USDA-NRCS

## **Approval**

Kirt Walstad, 3/01/2024

## **Rangeland health reference sheet**

Interpreting Indicators of Rangeland Health is a qualitative assessment protocol used to determine ecosystem condition based on benchmark characteristics described in the Reference Sheet. A suite of 17 (or more) indicators are typically considered in an assessment. The ecological site(s) representative of an assessment location must be known prior to applying the protocol and must be verified based on soils and climate. Current plant community cannot be used to identify the ecological site.

Author(s)/participant(s)	
Contact for lead author	
Date	05/17/2024
Approved by	Kirt Walstad
Approval date	
Composition (Indicators 10 and 12) based on	Annual Production

## Indicators

1. **Number and extent of rills:**

---

2. **Presence of water flow patterns:**

---

3. **Number and height of erosional pedestals or terracettes:**

---

4. **Bare ground from Ecological Site Description or other studies (rock, litter, lichen, moss, plant canopy are not bare ground):**

---

5. **Number of gullies and erosion associated with gullies:**

---

6. **Extent of wind scoured, blowouts and/or depositional areas:**

---

7. **Amount of litter movement (describe size and distance expected to travel):**

---

8. **Soil surface (top few mm) resistance to erosion (stability values are averages - most sites will show a range of values):**

---

9. **Soil surface structure and SOM content (include type of structure and A-horizon color and thickness):**

---

10. **Effect of community phase composition (relative proportion of different functional groups) and spatial distribution on infiltration and runoff:**

---

11. **Presence and thickness of compaction layer (usually none; describe soil profile features which may be mistaken for compaction on this site):**

---



12. **Functional/Structural Groups (list in order of descending dominance by above-ground annual-production or live foliar cover using symbols: >>, >, = to indicate much greater than, greater than, and equal to):**

Dominant:

Sub-dominant:

Other:

Additional:

---

13. **Amount of plant mortality and decadence (include which functional groups are expected to show mortality or decadence):**
- 

14. **Average percent litter cover (%) and depth ( in):**
- 

15. **Expected annual annual-production (this is TOTAL above-ground annual-production, not just forage annual-production):**
- 

16. **Potential invasive (including noxious) species (native and non-native). List species which BOTH characterize degraded states and have the potential to become a dominant or co-dominant species on the ecological site if their future establishment and growth is not actively controlled by management interventions. Species that become dominant for only one to several years (e.g., short-term response to drought or wildfire) are not invasive plants. Note that unlike other indicators, we are describing what is NOT expected in the reference state for the ecological site:**
- 

17. **Perennial plant reproductive capability:**
-