

Ecological site R044AH040MT

Loamy Steep Seeley, Swan, Flathead and Tobacco Valleys

Last updated: 9/07/2023
Accessed: 04/19/2024

General information

Provisional. A provisional ecological site description has undergone quality control and quality assurance review. It contains a working state and transition model and enough information to identify the ecological site.

MLRA notes

Major Land Resource Area (MLRA): 044A–Northern Rocky Mountain Valleys

This ecological site currently resides in the Major Land Resource Area (MLRA) 44A Northern Rocky Mountain Valleys. The area of MLRA 44A is huge and is in the process of being restructured into a new MLRAs further divided into new Land Resource Units (LRU). A detailed description of MLRA 44A can be found at: https://www.nrcs.usda.gov/wps/portal/nrcs/detail/soils/ref/?cid=nrcs142p2_053624

LRU notes

This LRU includes the Flathead Valleys, with the predominant landscape as valleys with landforms including floodplains, stream terraces, outwash, lacustrine terraces, foothills, glacial moraines. The estimated acres are 1,412,271 and it is primarily private lands. Land use is development and agriculture. Climatically, this LRU has a cryic/frigid soil temperature regime and a xeric/udic soil moisture regime. It has a mean annual air temperature of 6, mean frost free days of 94 and mean annual precipitation of 590 and REAP of 58. Elevations range 751-1835m. Vegetation is predominantly Douglas Fir-Ponderosa Pine-Lodgepole Pine Forest and Woodland. Minor Engelmann Spruce-Subalpine Fir, open water, developed areas and agriculture. Trace Western Redcedar and Western Hemlock and Grand Fir. The geology is predominantly fluvial and bedform topography related to Cordilleran glaciation. Rock types are dominantly metasedimentary of the Belt Supergroup (Ravalli group) with some Tertiary sediments, eolian deposits, open water, Glacial lake deposits. The soils are dominantly very deep well developed soils formed in alluvium, lacustrine deposits, glacial outwash and till from metasedimentary parent materials. These tend to be well drained, neutral to moderately alkaline soils with both skeletal and non-skeletal sandy loam, loam and clay loam textures. Poorly drained soils are present as well but are generally confined to areas along riparian corridors. Volcanic ash influenced soils occur here as well, but tend to be limited to stable footslope positions marginal to the valley floor.

This is related to the EPA land classification framework of: Level 3 the Northern Rockies and includes numerous Level 4 including: Stillwater-Swan Wooded Valley, Tobacco Plains, Flathead Valley, a small part of the Western Canadian Rockies (Level 3 is Canadian Rockies) and a small part of the rattlesnake-Blackfoot-south Swan-Northern Garnet-Sapphire Mountains and the Foothill Potholes (both in the Middle Rockies Level 3 subdivision). This area is related predominantly to the USFS Provinces: Predominantly resides in the northern portion in M333Bc (Flathead River Valley), the middle portion of in M333Cb (Canadian Rockies-Whitefish-Swan Mountains) and the southern portion in M332Bp (Avon-Nevada Valleys).

Classification relationships

NPS Plant Community Name:

Festuca campestris-*Festuca idahoensis*-*Geranium viscosissimum* Herbaceous Vegetation (CEGL005870)

Physiognomic Class Herbaceous Vegetation (V)

Physiognomic Subclass Perennial graminoid vegetation (V.A.)

Physiognomic Group Temperate or subpolar grassland (V.A.5.)

Physiognomic Subgroup Natural/Semi-natural temperate or subpolar grassland (V.A.5.N.)

Formation Medium-tall bunch temperate or subpolar grassland (V.A.5.N.d.)

Alliance *Festuca idahoensis* Herbaceous Alliance (A.1251)

Alliance (English name) Idaho Fescue Herbaceous Alliance

Association *Festuca campestris* - *Festuca idahoensis* - *Geranium viscosissimum* Herbaceous Vegetation

Association (English name) Prairie Fescue - Idaho Fescue - Sticky Geranium Herbaceous Vegetation

ECOLOGICAL SYSTEM(S): Northern Rocky Mountain Lower Montane, Foothill and Valley Grassland

(CES306.040)

Festuca campestris-(*Festuca idahoensis*)-*Achnatherum richardsonii* Herbaceous Vegetation (CEGL005869)

Physiognomic Class Herbaceous Vegetation (V)

Physiognomic Subclass Perennial graminoid vegetation (V.A.)

Physiognomic Group Temperate or subpolar grassland (V.A.5.)

Physiognomic Subgroup Natural/Semi-natural temperate or subpolar grassland (V.A.5.N.)

Formation Medium-tall bunch temperate or subpolar grassland (V.A.5.N.d.)

Alliance *Festuca idahoensis* Herbaceous Alliance (A.1251)

Alliance (English name) Idaho Fescue Herbaceous Alliance

Association *Festuca campestris* - (*Festuca idahoensis*) - *Achnatherum richardsonii* Herbaceous Vegetation

Association (English name) Prairie Fescue - (Idaho Fescue) - Richardson's Needlegrass Herbaceous Vegetation

ECOLOGICAL SYSTEM(S): Northern Rocky Mountain Lower Montane, Foothill and Valley Grassland

(CES306.040)

This vegetation community keys out to and is described by the Mueggler classification system (1980) as rough fescue-Idaho fescue which is a bunchgrass habitat types dominated by rough fescue, with different associated grasses, forbs and shrubs. The rough fescue-Idaho fescue habitat type (Mueggler, 1980) is described as usually dominated by rough fescue and Idaho fescue and bluebunch wheatgrass and shrubs are low in cover and may be absent. Timber oatgrass, western needlegrass and sedges are more prevalent. There is a diverse mixture of forbs including sticky geranium, prairie smoke, northern bedstraw, silky lupine and bluebells. Productive pothole grasslands in western Montana exhibit a high range in production, ranging from an average of 1125 to 2278 pounds per acre annually (Mueggler, 1980). Total biomass was dominated by graminoids (70-90%) with the remaining was in forbs and shrubs. Rough fescue dominated the graminoid biomass (30-85%) with Idaho fescue the next important grass, then bluebunch wheatgrass, western needlegrass and sticky geranium. Mueggler (1980) found that the effects of grazing depending on the intensity. Rough fescue declined with grazing, while Idaho fescue sometimes declined, but generally increased. Therefore, in heavily grazed areas rough fescue declined and Idaho fescue increased to dominance. Other increaser species included prairie Junegrass, threadleaf sedge, old man's whiskers and timber oatgrass. Cattle grazing in this community type should be keyed to the vigor of rough fescue, while sheep grazing to sticky geranium vigor. This is due to the fact that cattle preferentially graze rough fescue and sheep sticky geranium. On the drier end of this ecological site, the vegetation community resembles Mueggler's classification rough fescue-bluebunch wheatgrass. This is dominated by these bunchgrasses and has needle-and-thread, prairie Junegrass, variety of perennial forbs and scattered ponderosa pine and rose shrubs present. Generally, grasslands prevail over coniferous forests when precipitation is at or below 15 inches. Ponderosa pine has a competitive advantage over other coniferous species in its ability to rapidly elongate the root system in an environment of high moisture deficiency, but a period of low rainfall and high evapotranspiration during the hottest months prevents the establishment of full forests (Daubenmire, 1968).

Ecological site concept

Ecological Site Concept

- Site is found at low elevations, ranging from 800-1000 meters high, on moderate to steep slopes with all aspects on hillslopes or backslope or side slope positions on drumlins in larger valley landscapes
- Sites do not receive additional effective moisture
- Slopes are equal to or greater than 15%
- Stones and/or boulders do not cover more than 15% of surface area
- Vegetation is dominated by native, perennial, cool-season tufted bunch grasses. It is generally dominated by rough fescue (*Festuca campestris*), but can occur as mixtures with Idaho fescue (*Festuca idahoensis*), bluebunch wheatgrass (*Pseudoroegneria spicata*), and prairie Junegrass (*Koeleria macrantha*)
- Soils are:
 - o moderately deep, deep or very deep
 - o not saline or saline-sodic
 - o not skeletal within 20" of soil surface

- o not strongly or violently effervescent in surface mineral 4”
- o Clay content is <32% in surface mineral 4”,
- o argillic horizon if present has <35% clay of mineral soil
- o mollic epipedon is present
- o Surface textures usually range from very fine sandy loam to clay loam

Associated sites

R044AH036MT	Droughty Seeley, Swan, Flathead and Tobacco Valleys The Droughty ecological site is associated with the Loamy Steep ecological site and is found on lower slope positions with drier site conditions and more drought tolerant vegetation composition.
R044AH038MT	Droughty Steep Seeley, Swan, Flathead and Tobacco Valleys This Loamy steep ecological site is associated with the Droughty Steep ecological site that resides in drier site conditions with droughty soils.
R044AH032MT	Loamy Seeley, Swan, Flathead and Tobacco Valleys This steep ecological site is associated with the flatter Loamy ecological site, having similiar site conditons and soils.

Similar sites

R044AH032MT	Loamy Seeley, Swan, Flathead and Tobacco Valleys This ecological site is similar in soils, both of which are loamy, but differs in slope, in which this ecological site has moderate to steep slopes.
-------------	---

Table 1. Dominant plant species

Tree	Not specified
Shrub	Not specified
Herbaceous	(1) <i>Festuca campestris</i> (2) <i>Castilleja lutescens</i>

Physiographic features

This ecological site is found at low elevations, ranging from 2624 to 3280 feet high, on moderate to steep slopes with all aspects on hillslopes or backslope or side slope positions on drumlins in larger valley landscapes.



Figure 1.

Table 2. Representative physiographic features

Landforms	(1) Valley > Drumlin (2) Valley > Hillslope
-----------	--

Elevation	2,624–3,280 ft
Slope	15–55%
Water table depth	60 in
Aspect	W, NW, N, NE, E, SE, S, SW

Climatic features

The dissected northern Rocky Mountain Valleys are considered to have a maritime climate. Precipitation is fairly evenly distributed throughout the year with less than about 35 percent of the annual precipitation occurring during the growing season in Montana. Rainfall occurs as high-intensity, convective thunderstorms in the spring and fall. Most of the precipitation in the winter is snow or rain on fully or partially frozen ground. Average precipitation is 14 to 19 inches, and the frost-free period averages 60 to 100 days. The soil moisture regime is xeric and the soil temperature regime is frigid. The majority of precipitation comes early in the form of snow and spring rain. Summers are usually dry. The growing season is short and cool; primary growth typically occurs between May and July, and dominant plants are those that have adapted to these conditions. There is abundant moisture available during the cooler months and very little during the period of mid-to late summer drought conditions, many native bunchgrasses and forbs are dormant in summer but photosynthetically active from autumn through spring. For example, throughout all the valleys of western Montana, the months with higher precipitation average were November to January and May to June.

Mean Average Precipitation Range 14-19 inches
 Mean Average Annual Temperature Range 33-58 degrees
 Frost free days Range: 60-100

Table 3. Representative climatic features

Frost-free period (characteristic range)	61-90 days
Freeze-free period (characteristic range)	111-132 days
Precipitation total (characteristic range)	16-21 in
Frost-free period (actual range)	23-94 days
Freeze-free period (actual range)	93-133 days
Precipitation total (actual range)	15-22 in
Frost-free period (average)	71 days
Freeze-free period (average)	119 days
Precipitation total (average)	18 in

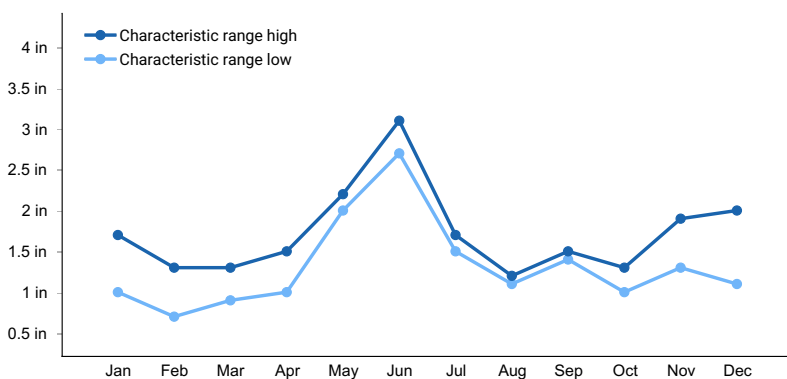

Figure 2. Monthly precipitation range

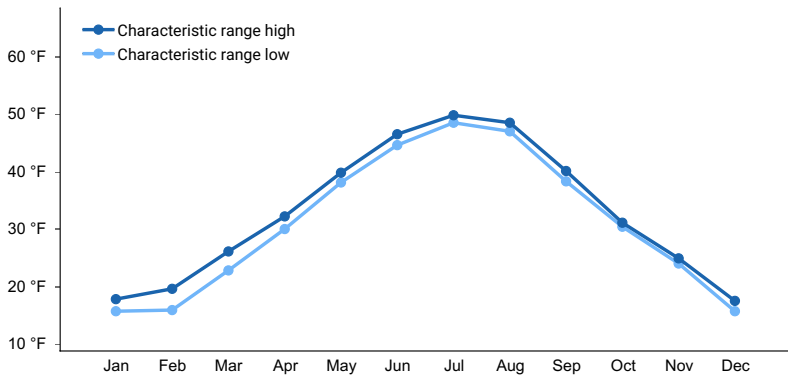

Figure 3. Monthly minimum temperature range

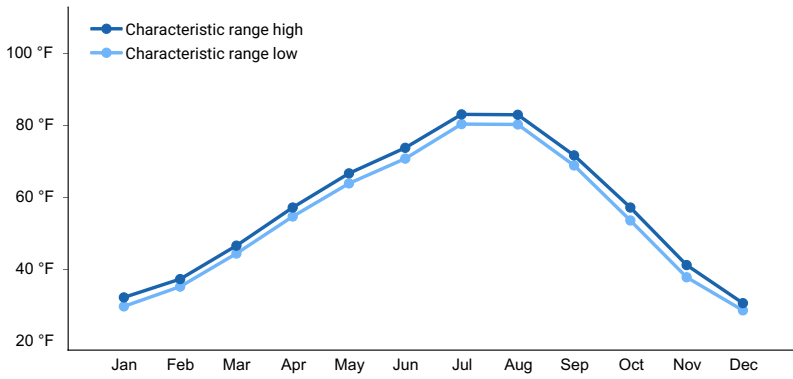

Figure 4. Monthly maximum temperature range

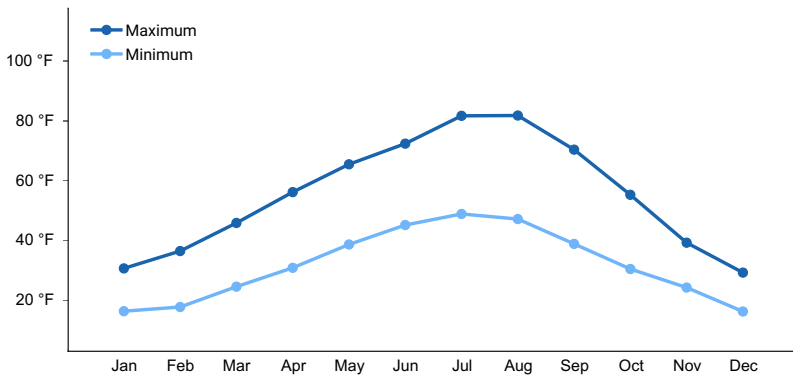

Figure 5. Monthly average minimum and maximum temperature

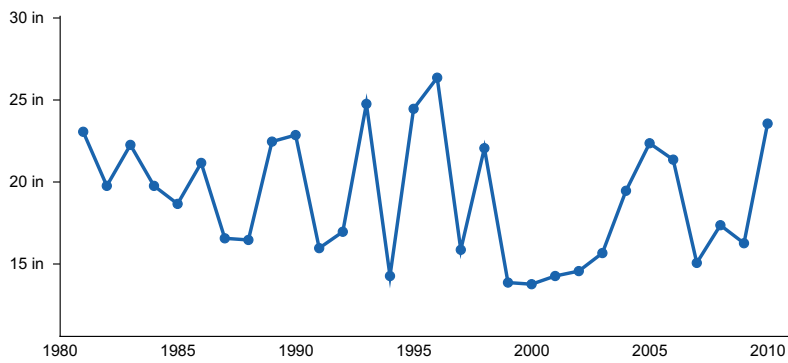

Figure 6. Annual precipitation pattern

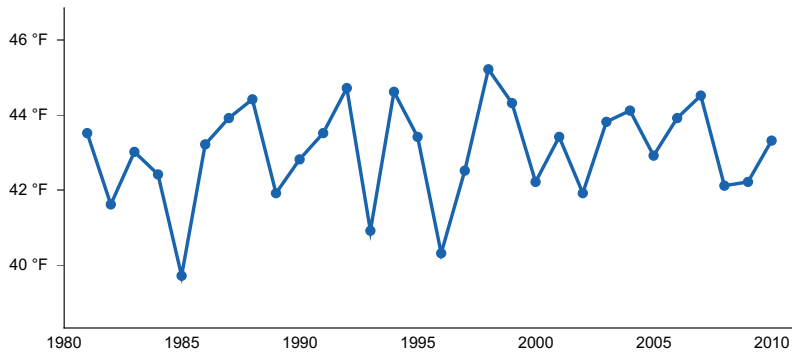

Figure 7. Annual average temperature pattern

Climate stations used

- (1) EUREKA RS [USC00242827], Eureka, MT
- (2) FORTINE 1 N [USC00243139], Eureka, MT
- (3) OLNEY [USC00246218], Whitefish, MT
- (4) WHITEFISH [USC00248902], Whitefish, MT
- (5) KALISPELL 9 NNE [USC00244560], Kalispell, MT
- (6) CRESTON [USC00242104], Kalispell, MT

Influencing water features

No water features associated.

Soil features

This ecological site has soils that are very deep, well drained, and formed predominantly from glacial till parent materials. These soils typically have a gravelly loam or gravelly silt loam surface and gravelly sandy clay loam subsurface textures. The rock fragment content does not exceed an average of 35 percent by volume in the 10 to 20 inch layer. Surface textures (less than 2 mm) usually range from very fine sandy loam to clay loam and the typical clay content is less than or equal to 32 percent. Thin argillic horizons, if present, are generally not considered to be diagnostic and have less than 35 percent clay. The deep dark surface horizon with high base saturation, called a mollic epipedon, that is present in these soils indicate that they have consistently supported grassland vegetation over time. Their dark color is due to the incorporation of organic matter into the soil from the roots of grass and forb species and is indicative of productive rangeland sites. These soils are classified as Mollisols, and the thickness of the dark mollic surface layer averages 38 cm (26 to 62 cm). Many of these soils have a zone of weak development or cambic diagnostic horizon that overlies a zone of accumulation of calcium carbonate called a calcic diagnostic horizon and are classified as Calcic Haploxerolls. Surface organic layers when present are usually less than 5 cm thick. Diagnostic features include a mollic epipedon and a cambic and calcic subsurface horizons (Soil Survey Staff, 2015).

The soils of the loamy steep ecological site represent the productive and solar-sheltered aspects of the glacial valley features such as drumlins. South-facing solar gaining slopes tend to experience more erosive forces over time and typically have an ecological site of droughty steep, whereas, more northerly-facing solar-sheltered aspects tend to have a greater accumulation of fines, more incorporation and retention of soil organic matter and higher vegetative diversity and production.

For more information on soil taxonomy, please follow this link:

http://www.nrcs.usda.gov/wps/portal/nrcs/detail/soils/survey/class/?cid=nrcs142p2_053580



Figure 8.

Table 4. Representative soil features

Parent material	(1) Till–metasedimentary rock
Surface texture	(1) Loam (2) Gravelly loam
Family particle size	(1) Loamy
Drainage class	Well drained
Permeability class	Moderately slow to moderately rapid
Soil depth	60–100 in
Surface fragment cover <=3"	0–3%
Surface fragment cover >3"	0%
Available water capacity (4-7.5in)	Not specified
Calcium carbonate equivalent (0-20in)	Not specified
Electrical conductivity (0-1in)	Not specified
Sodium adsorption ratio (0-4in)	Not specified
Soil reaction (1:1 water) (6-8.2in)	Not specified

Ecological dynamics

The Loamy Steep ecological site is dominated by native, perennial, cool-season tufted bunch grasses. It is generally dominated by rough fescue (*Festuca campestris*), but can occur as mixtures with Idaho fescue (*Festuca idahoensis*), bluebunch wheatgrass (*Pseudoroegneria spicata*), and prairie Junegrass (*Koeleria macrantha*). While highly dominated by grass species, forb species do occur in high frequency but low cover including stiff yellow Indian paintbrush (*Castilleja lutescens*), silky lupine (*Lupinus sericea*) and blanketflower (*Gaillardia aristata*). Other associated montane forbs include yarrow (*Achillea millefolium*), old man's whiskers (*Geum triflorum*), western stoneseed (*Lithospermum ruderale*), largeflower triteleia (*Triteleia grandiflora*), subshrubs including rosy pussytoes (*Antennaria rosea*). Shrubs with very low cover occur, including Woods rose (*Rosa woodsii*), and common snowberry (*Symphoricarpos albus*).

There is scant historical references for the Loamy Steep ecological site. The most similar ecological site with historical reference is the Loamy ecological site. A literature reference (Ross et al, 1974) for pristine Loamy ecological sites in the 15 to 19 inch precipitation range in western Montana (Rocky Mountain Area) is recorded as having the following percent composition by weight for species: rough fescue 17 to 92 percent, Idaho fescue trace

to 40 percent, basin wildrye 0 to 20 percent, prairie junegrass trace to 5 percent, needle-and-thread grass 0 to 2 percent, western wheatgrass/slender wheatgrass/thickspike wheatgrass 0 to 2 percent, Richardson's needlegrass 0 to 10 percent, Columbia needlegrass a trace to 1 percent, timber oatgrass 0 to 1 percent, perennial forbs 5 to 20 percent and shrubs a trace to 8 percent. Shrubs at this site include yellow rabbitbrush, shrubby cinquefoil, big sagebrush, threetip sagebrush and white sagebrush. In a comparison of non-grazed and grazed sites for the Loamy 15 to 19 inch precipitation range, Ross (1974) found that at four sites, rough fescue and basin wildrye composition was greatly reduced, shrubs were greatly increased and perennial forbs were reduced. Other grasses increased with grazing as rough fescue decreased. The particular species of increaser depended on what was present in the community before grazing including Sandberg bluegrass, Kentucky bluegrass, Richardson's and Columbia needlegrasses, Idaho fescue, prairie Junegrass, timber oatgrass and threadleaf sedge.

This grassland is considered intermediate between the Pacific Northwest Bunchgrasses in the Columbia Basin and the Mixed Prairie of the Great Plains. It has species that are representative of both of these vegetation communities. The rough fescue community is where the climate shifts from the Columbia Basin with summer low but winter high precipitation to the Great Plains with summer high but winter low precipitation. This is a very productive grassland due to the soils and climate of the area.

These grasslands are adapted to a frequent fire regime that reduced the encroachment of woody shrubs and trees. Historically, the fire frequency is difficult to determine but is thought to average 20 to 30 years. These fires were generally from lightning strikes during the hot mid-to-late summer months. The bunchgrasses and perennial forbs of this vegetation community are tolerant of fire by resprouting and from underground roots and tubers. In general, the bunchgrasses and native perennial forbs complete their life cycles by the onset of summer drought and enter a dormant state (aestivation) which coincides with the fire season. These fires are less harmful since the plants are dormant. Fire is essential to this community as it prevents woody invasion and removes heavy accumulation of litter that suppresses biodiversity. Rough fescue is adapted to periodic burning by their growth form of dense, tufted bunch that insulates perennating buds located near the ground surface. It recovers from fire by tillering, sprouting from residual plants and from on-site and off-site wind-dispersed seed. Rough fescue is initially top-killed, but then recovers to pre-fire coverage usually in 2 to 3 years. There may be reductions in plant vigor following fires in the growing season more so than in dormant season burns. When fire suppression has occurred, rough fescue accumulates heavy litter within large diameter crowns and survival may be severely inhibited as crowns tend to continue to long after the passage of the flame front. If a hot fire occurs during the growing season and there is heavy litter accumulation, then fire effects can be severe. Spring burns can reduce seed production in rough fescue although fall burns have no effect. Fall burns may have reduced fire effects from elevated soil moisture, but may increase the chance of wind or water erosion, leaving rough fescue more susceptible to frost damage. Fires are most damaging when native bunchgrasses are actively growing in late fall, winter and early spring.

SPECIES DESCRIPTIONS OF DOMINANT GRASSES

Rough fescue is a native, cool-season, perennial bunchgrass that produces thick mats of persistent sheath and stem bases and culms that grow to 3.5 feet, and leaf tufts that grow to 16 inches in height (Cronquist, 1977). It has extensive fibrous roots to a depth of 4 feet, 73 percent of which are concentrated in the top 6 inches of soil (Coupland, 1953). Rough fescue regenerates from seed, tillers, and sometimes creeping rhizomes (Pavlick, 1984). It is well adapted to a short growing season by initiating growth following snowmelt, and completes growth before the onset of summer drought and can have fall regrowth. It is very productive and highly palatable to livestock and wildlife. Rough fescue is used by bighorn sheep, mule deer, elk, and bison (Lesica and Cooper, 1997). Rough fescue is highly palatable forage. It is prime winter forage: plants cure well on the stalk and retain high nutrient levels during dormancy. It is resistant to moderate grazing, but heavy grazing can result in severely decreased root depth and biomass (Aiken, 1990). Grazing can cause a general decline in rough fescue coverage, and it is one of the first species to decline (along with thickspike wheatgrass and Richardson's needlegrass) with a concomitant increase of common increaser species, such as Idaho fescue, other needlegrass species, prairie Junegrass, prairie junegrass and Parry's oatgrass (Mueggler, 1980).

Rough fescue and elk sedge are considered very resistant to human trampling due to its tough core, according to D. Cole of the USFS in his study of recreational human trampling effects on habitat types in western Montana. The majority of the loss of cover, a reduction of 50 percent, occurred in the first 400 passes. Thereafter, cover loss was stabilized from 400-800 passes. The community of rough fescue-timber oatgrass is considered very resistant to both light and heavy trampling (Cole, 1987).

Rough fescue is well adapted to periodic burning and resistant to light severity fire because of their dense, tufted

habit. It sprouts from surviving residual plants and colonizes from off-site wind-dispersed seed. Fire may top-kill plants, but normal cover and production usually is attained in 2-3 years post-fire. Severe damage can occur by hot, mid-summer wildfires (Wright, 1982).

Bluebunch wheatgrass is a native, cool-season, perennial grass that is densely tufted and is among the most drought-resistant native bunchgrasses. It is capable of an unusually broad range of osmoregulation, which helps it survive under a range of moisture conditions. It thrives best in the 14-17 inch precipitation zone in the Intermountain West, but can be found as low as the 10 inch precipitation zone. It requires excellent drainage and mostly full sun. It is considered one of the most important forage grasses for both livestock and wildlife, although it is not necessarily the most highly preferred species. It is also nutritionally sufficient for some animals for only part of the year. It is moderately grazing tolerant only during its non-growing season and extremely sensitive to defoliation during active growth. It is susceptible to competition from weedy invasives including diffuse and spotted knapweed, crested and desert wheatgrass. Bluebunch wheatgrass survives fires because its buds are protected by soil and/or plant foliage. It can be top-killed, but generally does not usually result in plant mortality. Burning stimulates flowering and seed setting. The timing of burning affects mortality in that more are killed in spring growing season and less in summer dormancy. Recovery post fire usually requires one to three years, with availability of soil moisture as an important factor determining time.

Idaho fescue is a long-lived native perennial cool-season bunchgrass. It is densely tufted with fine leaves. The root system is strong and can extend 16 inches deep (Hanson, 1959). In well drained soils, the root biomass is greatest at depths of 2 to 4 cm. Reproduction is from seeds and tillers, although seed production is variable (Stubbendieck, 1992). Idaho fescue is found in more mesic grasslands and is considered a climax species. It can survive fires of light severity, but usually is harmed by more severe fires (Smith, 1981). Rapid tillering of Idaho fescue occurs where root crowns are not suppressed and soil moisture is favorable. Plants may re-establish from seed after fire if the burn temperatures are low enough to allow for survival of seed in the soil. Idaho fescue can decrease with heavy grazing or severe fire and be succeeded by native and non-native increaser species including bluegrass and needlegrass grass species, sagebrush, lupine, phlox, and the invasive timothy (*Phleum pratense*) (Eckert, 1987). Idaho fescue is an important forage species for livestock (cattle, sheep, and horses) and wildlife species including elk and mule deer (Mueggler, 1980). It is particularly important in elk diets throughout the Rocky Mountain region.

Hansen et al. (1995) found that Idaho fescue is good forage for cattle, horse, and sheep: it has high energy value and medium protein values in the fall and winter. Sticky geranium is good sheep forage, but only fair for cattle and horses: it has low energy and protein values in fall and winter. Sticky geranium also is considered good food value for elk and whitetail and mule deer, but poor for antelope and for bird species. Old man's whiskers (*Geum triflorum*) is considered fair to poor forage for cattle, sheep, and horses. It contains low energy and protein values in fall and winter. It has fair to poor food value for elk, whitetail and mule deer, and antelope, and also for bird species.

Prairie junegrass is a cool season perennial bunchgrass that is loosely-tufted, shallow-rooted and of small stature with long, mostly basal leaves. The leaves are drought resistant and persist under dry conditions. The roots are moderately long, 13-30 inches and root density decreases after 12 inches, with the greatest concentration in the upper 1.2 inches. Regeneration is from seed, which ripens late summer to fall and by sprouting from residual plants. It develops rapidly in early spring, flowers in Montana from May to July, and it avoids growth in driest summer months. Prairie junegrass occurs in numerous prairie and grassland habitats, at least in a small percentage. Preferred sites are cool, semi-arid or xeric infertile grasslands and rock outcrops with annual precipitation range from 16 to 21 inches. Livestock and several wildlife species utilize it as it provides good, early spring forage although due to its scattered distribution it is not a significant role in most wildlife species. Prairie junegrass sustains little to moderate damage from fire due to its small clump size and coarsely textured foliage which burn quickly and perennating buds near or below the soil surface which are insulated against fast moving fires. Damage is dependent on fire severity, physiological state of plant, soil moisture and season of burn. Survival strategy is through seed germination and residual plant survival.

Needle and thread grass is a cool-season, native, perennial bunchgrass that is moderately to highly drought resistant and recovers well from drought. It has small and widely spaced bunches that are shallow to medium-rooted and produce numerous fibrous roots. It reproduces by seed, which are long-lived, and tillers. It is common on dry hills and plains and on stony and sandy soils with slightly high pH, low water holding capacity, low clay percentage and high bulk density. In Montana, it grows best in the 10 to 18 inch precipitation zone. It is generally considered early or mid-seral species. It begins growth in spring and becomes dormant during hot weather. It can

be important to livestock and wildlife, in Montana cattle, mule deer and pronghorn, especially in early spring. In summer, the fruit has a sharp awn that may injure grazing animals. It is considered severely damaged by fire, depending on the severity of fire. After fire, needle and thread grass sprouts from the caudex, if heat has not been sufficient to kill the underground plant parts. It recovers in 2 to 10 years from fire.

Columbia needlegrass is a native, cool-season, perennial bunchgrass that grows in dense, leafy tufts and is long-lived and drought tolerant, with slow to moderate seedling growth rate and medium herbage volume, with deep and fibrous roots. Columbia needlegrass reproduces by seed and tillers (though this has been disputed). Columbia needlegrass has a sharp pointed callus (a hard projection at the base of a floret, spikelet, or inflorescence segment) which aids in dispersal but causes it to be avoided for forage, which promotes stand replenishment. In Montana, it is good forage for cattle, horses and mule deer. Columbia needlegrass prefers well-drained, fine-textured soils with clay loam to sandy loam surface texture and has low fertility requirements and good heat tolerance, can grow on shallows soils, moderately tolerant of salinity, and can grow on dry, rocky infertile sites. Columbia needlegrass grows on a wide variety of middle and upper elevation sites. Columbia needlegrass begins growth during the early spring is most seriously injured by midsummer fires and less by late spring or fall burns. It is among the least fire resistant bunchgrasses due to its densely tufted stems but because it has relatively few culms per clump, it ranges only slightly to moderately damaged by fire.

Richardson's needlegrass is a native perennial cool-season bunchgrass with fine stems. It is shallow-rooted and clay accumulation can restrict roots (Lackschewitz, 1991). Richardson's needlegrass becomes dormant following the depletion of surface soil moisture during the latter part of the growing season (Nimlos, 1968). It reproduces by seed and is wind- and animal-dispersed (Tyser, 1990). Richardson's needlegrass is considered a climax codominant species, meaning that while it is found in the climax community, it is usually co-dominant with rough fescue (Koterba, 1971). In general, perennial needlegrasses are among the least fire-resistant of the bunchgrasses, especially with midsummer burns: the accumulated dead culm and leaves makes them more susceptible to burning. Perennial needlegrasses often survive low-intensity fires as the heat is not transferred below the soil surface, only top-killing plants (Wright, 1965). Richardson's needlegrass is an important forage species for livestock and wildlife especially deer, bighorn sheep, and elk.

EFFECTS OF LAND MANAGEMENT PRACTICES ON ECOLOGICAL DYNAMICS AND INVASIVE SPECIES INVASION THEORY

There are threats to the mesic rough fescue grasslands include habitat fragmentation, habitat degradation from weed invasion, improper livestock grazing, and alteration of fire regime and herbicide drift (Hill and Gray, 2004). Habitat fragmentation is caused by development, roads, agriculture or other human activities that create small patches of the vegetation community. The effects of creating small patches of vegetation are to limit pollinators associated with plant species, limit genetic mobility of species with inbreeding depression and other genetic pressures associated with small population size. Habitat degradation is a decline in habitat that alters the structure, function, and composition of the habitat. Improper livestock grazing can cause changes to plant community through preferential grazing of certain species, changes to soil and hydrology function. A grazing induced change in vegetation community structure away from native bunchgrasses that have high canopy cover and therefore lower bare soil cover can increase soil erosion. Trampling of vegetation by livestock can also reduce plant vigor. Livestock can introduce non-native species into the native community. Variation in fire regimes from historical occurrence can cause vegetation community dynamics to change, particularly when fires occur in different season than was common under the historic frequency. Fire suppression can cause potentially devastating and severe fires due to litter accumulation after longer time between fires. Suppression can also allow for encroachment by woody shrub and tree species. An increase in fire cycles can also be detrimental to bluebunch wheatgrass-Idaho fescue grasslands by reducing the post-fire recovery time and native plants may be vulnerable to alien competition. As well, fires that are out of season to historic fire cycles, can cause higher mortality if occurring during the growing season. Herbicide drift from adjoining agricultural lands to mesic rough fescue grasslands can negatively impact the vegetation community of bunchgrasses and perennial forbs with lower vigor or mortality.

Invasion of weedy species into native vegetation communities requires an understanding of the processes and mechanisms by which an invasion occurs. Weedy species degrade native habitat by altering its structure, composition and function. Weedy species often outcompete, invade and displace native plant communities. Weedy invasions reduce canopy cover of large perennial plants and increase the cover of bare ground. Bare ground can result in increased soil erosion resulting in changes in soil structure and chemical composition and alter microclimate. Weedy species can also change ecological processes of the native community such as productivity, soil water, nutrient dynamics, community successional patterns and disturbance cycles. Resistance and resilience of the native community are essential elements in predicting the success of the invasion. There are two counter

point theories on invasive species. The driver theory considers the invasive species to be driving species decline while the passenger model sees the invading species as filling in empty niches left by habitat alteration (Didham, 2005). The passenger model suggests that disturbance is the cause and if stopped, invasion can be reversed. Potential mechanisms of invasion include theories such as novel weapons, enemy release, competitive superiority, and manipulation of environment. "Weedy species can outcompete native species if they have rapid germination and growth, relatively short maturation times, high reproductive and seed output, a large seedbank and efficient dispersal mechanisms that can facilitate their spread". Novel weapons include biological weapons or associations with micro-organisms that allow the invader species to either access new resources or steal them from indigenous plants (Tannas, 2011). Specifically, arbuscular mycorrhizal fungi may provide a substantial competitive advantage to spotted knapweed by carbon parasitism (Carey, 2004). In these cases, the invader uses these weapons to drive the invasion process. Enemy release describes the concept that once invader species are released from their native predator species or chemical warfare within their original community, they are more aggressive in their new community (Blumenthal 2006, Callaway and Aschelhoug 2000). The invader species may have characteristics that allow it to be more competitive than resident plant species such as grazing resistance, adaption to a harsh environment or another competitive ability (Tannas, 2011). Invading species can manipulate the environment to their advantage through resource competition. Mechanisms include modifying light interception, water uptake efficiency or change in soil water holding capacity, nutrient uptake and cycling (D'Antonio and Vitousek, 1992). The final outcome of invasion is establishment of the invading species which occurs as either dominance, coexistence, or exclusion from the indigenous plant community (Seabloom, 2003). D'Antonio and Vitousek (1992) stated grass invasions are of particular concern because they are actively moved by humans, exotic grasses compete effectively with native species, they may change nutrient cycling, modify regional microclimates and can alter fire dynamics.

INVASIVE SPECIES DESCRIPTIONS

Specifically, scientific literature on invasions by Kentucky bluegrass, smooth brome, spotted knapweed, leafy spurge and Canada thistle into rough fescue grasslands in Canada and Montana will be reviewed. Species in bold are on the Montana State listed Noxious Weeds List (Montana Department of Agriculture, 2003): spotted knapweed (*Centaurea stoebe*), leafy spurge (*Euphorbia esula*), and Canada thistle (*Cirsium arvense*). Kentucky bluegrass invasion into rough fescue grasslands can take multiple pathways. Heavy grazing of rough fescue which reduces litter amount combined with timing of defoliation, winter versus growing season and abiotic factors like seasonal variation in soil moisture content can make native grasslands less resistant to invasion (Douwes, 2012, Tannas, 2012). Resilience of the native grassland is dependent on vigor and density of rough fescue and restoration establishment is more successful with cuttings and plugs than seeding (Tannas, 2011).

Although, seeding rough fescue as a monoculture is effective (Sherritt, 2012). A study of grazing effects on a rough fescue at Stavely grassland, a Canadian research station, found that heavy grazing pressure by cattle resulted changes in plant species composition to an increase in shallow rooted species, less productive overall, but more resistant to grazing (Dormaar, 1990). In a study of seasonal biomass changes, Willms (1996) found that with grazing intensity the vegetation community composition shifted from one dominated by rough fescue to one dominated by parry oatgrass-Kentucky bluegrass in moderately grazed pastures to Kentucky bluegrass-sedge species in heavily grazed pastures. The rough fescue dominated community had the greatest forage value compared to communities resulting from moderate, heavy and severe grazing (Willms, 1996). More than 20 years of drastically reduced stocking rates were required to enable recovery (Willms, 1985). Soils associated with heavy grazing were transformed to a soil more characteristic of a drier microclimate (Johnston, 1962 and 1971), by reducing the thickness of Ah horizon, reducing percent organic matter and soil moisture and increasing soil temperature with grazing intensity. Heavy grazing also reduced the fertility and soil water holding capacity (Dormaar, 1998).

Soil organic matter, and nutrient cycling differed between grazed and ungrazed rough fescue grasslands (Willms, 1988). At a watershed scale, heavy grazing lead to larger summer storm and spring snow melt runoff compared to watersheds with less grazing (Chanasyk, 2002). The quantity and quality of surface runoff from these watersheds showed that grazing posed little risk of nutrient contamination of adjacent streams (Mapfumo, 2002).

There was less snow accumulation in heavily and moderately grazed watersheds (Willms, 2006). A study on the effects of grazing on germinable seeds found that soil disturbance in fescue grassland is more likely to lead to a seral community dominated by annual broad-leafed plants, than a rough fescue dominated grassland (Willms, 1995). Skim grazing (light, once-over-spring defoliation) by cattle was not conducive to rough fescue conservation (Moisey, 2005). Rough fescue tolerated light winter-early spring elk grazing but not heavy grazing (Thrift, 2013). A rough fescue grassland in Rumsey Block, Alberta Canada tolerated moderate grazing which resulted in a

community co-dominated with shortbristle needle and thread while heavy grazing and/or moderate to major oil and gas disturbance crossed a threshold requiring complete eradication of species and reseeding (Desserud, 2014). A study of effects of human caused disturbance in rough fescue grasslands in Manitoba Canada, found it depends on invasive species introduction history (Gifford, 2013). Kentucky bluegrass tolerates grazing and can increase in abundance after heavy grazing. Therefore, Kentucky bluegrass resided in historically grazed areas, while smooth brome occurred along roads. In a study of smooth brome on rough fescue grasslands in Saskatchewan Canada, found that it is likely the combination of traits of smooth brome (higher productivity, abundant production of lower quality litter, clonal growth, and greater nutrient uptake capability) that allows it to invade native prairie (Piper, 2015). Smooth brome had a consistent negative impact on community structure and function across 8 grasslands in Alberta Canada with the impact on native species richness higher in species rich areas, while impact on native biomass was larger in productive, warmer and more variable sites (Stotz, 2016).

The noxious weed spotted knapweed was found to strongly reduce the final biomass and reproduction of native Idaho fescue grasslands. An insect biocontrol agent had little effect on spotted knapweed, while a native fungal pathogen killed it in a common garden experiment in Missoula Montana (Ridenour, 2003). Invasion of grasslands by spotted knapweed are mediated by root exudation of catechin, a potent phytotoxin Perry (2005). Catechin resistance was positively correlated with mean seed mass for eight species identified as resistant: Mountain brome, curlycup gumweed, needle and thread grass, basin wildrye, cicer milkvetch, boreal sweetvetch, common blanketflower, and alfalfa. Perry (2005) further found that residual soil catechin may interfere with reestablishment of native grassland species even after spotted knapweed populations are controlled.

Leafy spurge has an extensive rhizomatous root system, a deep root system up to 30 feet that can access water sources not available to many native plants, potential allelopathic properties and all parts contain high starch latex which seals wounds and is a possible deterrent against insect attacks. Areas with leafy spurge invasion that have been treated with herbicide application and mechanical removal still had higher bare ground area, significantly lower soil arthropod densities and lower plant species richness and cover (Pritekel, 2006). Jordan (2008) found that invasive plants, specifically leafy spurge, smooth brome and crested wheatgrass, are capable of modifying soil microbiota to facilitate further invasion by conspecifics and other invasive species. These soil alterations have the potential to impede restoration of native communities after removal of an invasive species. Successional management may require repeated treatments to achieve a desired outcome. Pokorny (2009) found that while broadleaf herbicide applications decreased hoary cress, Canada thistle and undesired forbs within a leafy spurge invaded site, the results were temporary and seeding was necessary for native species establishment. Leafy spurge has been effectively controlled and managed with biological control agents, particularly black and brown flea beetles. Butler (2006) found that black flea beetles significantly reduced the foliar cover of leafy spurge with black flea beetle release in a study in northwestern Dakota and southeastern Montana. Grass and grass-like plant cover increased but forb cover did not reach the non-infested levels. In another study in southeastern Montana, (Butler, 2010) found that the native vegetation did not recover to the extent assumed possible. While leafy spurge foliar cover was significantly reduced with use of the biological control agent black flea beetle, non-native *Poa* species became dominant while the native species did not recover completely.

Use of biological control agents on leafy spurge have been successful in Montana although the recovery of the native vegetation community has been mixed. Lesica (2004) found in a study of black fleas controlling leafy spurge that the response of the weed and the native vegetation community depended on abiotic factors and previous herbicide use. In all areas, the black fleas resulted in a decrease of aboveground leafy spurge biomass, the difference between areas were size in reduction of the weed and the proportion of vegetative to flowering stems of leafy spurge. Areas that were more stressful (poor soils) had greater reductions than areas less stressful (good soils). Areas with good soils that also had previous herbicide use, when treated with black fleas, produced more vegetative and less flowering stems in leafy spurge and slowed the recovery of species diversity compared to control areas which had experienced an increase of diversity over the same time period. The opposite effect was found in areas with poor soils and no previous herbicide use, with more flowering stems produced by leafy spurge and an increase in species diversity as compared to control plots.

Butler (2010) found that black flea beetles released in western Montana resulted in very large reductions of leafy spurge, but the native vegetation community did not regain its diversity compared to areas that were non-infested. The infestations of leafy spurge have been reduced significantly but then Kentucky bluegrass replaced leafy spurge in dominance. Functional groups that were able to persist during the leafy spurge invasion continued to be present after it was reduced. Non-infested areas were dominated by native species. This has been theorized by Carson (2008) as the associated species factor in why native vegetation does not recover fully after invasive species have

been controlled. The co-occurring non-native species quickly invades that area previously occupied by the initial invasive weed species.

Butler (2006) found that in southwestern Montana, released black and brown flea beetles differed in their ability to quickly establish and reach their maximum population size within two years. The black flea beetles outcompeted the brown flea beetles. The cover of leafy spurge was significantly reduced. Concomitant with the reduction in leafy spurge, grass and grass-like species increased cover while forb species did not reach the non-infested area cover. Livestock tend to avoid high stem density leafy spurge infestations. Therefore, once stem densities were reduced, livestock grazed the area and remaining grass species and caused a slight decline in cover. Forb cover did not achieve non-infested area covers even after leafy spurge cover was reduced. Leafy spurge has a strong filtering effect on the resident vegetation community and forbs are more heavily impacted than graminoid species.

Butler (2004) evaluated vegetation communities in Theodore Roosevelt National Park in southwestern North Dakota. The vegetation communities in which leafy spurge infestation occurred were divided into control and infested plots. Infested plots on the whole had 61 percent less species diversity than control plots. Species were rated as either sensitive or persistent to infestations. Thirty species that were common in the control plots of the various vegetation communities were absent in the infested plots. Forbs were far more sensitive than graminoid species to leafy spurge infestations leading to the conclusion that leafy spurge has a strong filtering effect on resident native vegetation communities. Overall, species richness on infested plots were significantly lower than on control plots throughout the eleven vegetation communities sampled.

Carson (2008) described factors that could cause a biological control agent released onto infestations to fail to recover the native vegetation community as indirect or direct effects of the invasive plant: native source limitations, novel weapons, static competitive hierarchy, trophic shifts, invasive engineering and associated invasive species. The first three are direct effects, the next two are indirect effects of the invasive species and the last can be attributed to either. Native source limitations refer to the inability of the native species to reproduce effectively to outcompete the invasive species due to lower relative abundance of seedbank or individuals to disperse seed. As well, numerous invasive species produce copious amounts of seed, effectively store seeds for long periods and form monotypic stands which are dominate the soil beneath it with its own seed. Biocontrol agents would need to target the invasive species' most vulnerable life form to effectively reduce numbers i.e. like reducing seed set. Novel weapons are generally exudates from the invasive species that facilitates its invasion and persistence to the detriment of the native vegetation and its soil microbial community. Biological control agents that sufficiently negate these allelopathic chemicals can have success. Static competitive hierarchy refers to an invasive species that is a superior competitor for resources compared to native species. The biological control agent would need to reduce the invasive species ability to dominate resource acquisition and allow native species to become superior in order for it to be successful recovery. In the indirect effects factor of trophic shifts, the invasive plant changes the trophic levels (relationships) within an ecosystem to the disadvantage of the native community. Trophic levels include predators, parasitoids, mutualists, pathogens and herbivores. The relationship between soil microbiota and plants is host specific, therefore a monotypic stand of an invasive species can change the soil microbiota even after it has been reduced in aboveground biomass. This change in microbiota can make it difficult for native species to re-establish in the area. As well, a dominant invasive species may either become preferential food for native pollinators thereby lowering their use of native species or an invasive species may change the pollinator species composition. Lastly, invasive species can change herbivore behavior. In invasive engineering theory, the invasive species changes the abiotic environment to such a degree that the native species cannot dominate even after reduction of the invasive species. This can occur in wetlands in which the invasive species has change the hydrology. Therefore, a manipulation of the hydrology must occur as well as a reduction or elimination of the invasive species for the native community to recover. The last scenario of biological control failure occurs when a co-occurring invasive species to the dominant invasive, takes over an area after the dominant species is removed or reduced. The native vegetation cannot recover in the face of the secondary invader.

Steinger (1992) studied the effects of two biological control insects, a moth and a weevil, on spotted knapweed. As well, they tested if differences in nitrogen levels and graminoid competition affected the outcome of herbivory. Spotted knapweed responded to the root herbivory by compensatory root growth and therefore lower shoot growth. This was especially prevalent in low nitrogen levels with herbivory by the weevil in which shoot growth was reduced 60%. The weevil caused changes in the shoot to root allocation of spotted knapweed in response to its herbivory, shoots decreased but not roots, as well as more nitrogen concentration in roots than in shoots. Compensatory allocation to roots with herbivory was observed. Competition with grass resulted in lower shoot and root growth and smaller leaves. This competition was more detrimental to plant growth than herbivory or nutrient supply. Lower

nitrogen affected spotted knapweed's ability to compensate for root herbivory with additional root growth. There was greater reduction in spotted knapweed with herbivory and reduced nitrogen availability. Root herbivory greatly affected the physiology of spotted knapweed with greater allocation of nitrogen and energy to the roots and less to shoots.

Sulphur cinquefoil (*Potentilla recta*) has high ecological amplitude, it is found in numerous forested and non-forested vegetation communities in Montana. Sulphur cinquefoil flourishes in Montana's semiarid climate in areas similar to those inhabited by spotted knapweed. Sulphur cinquefoil is native to southeastern Europe and southwestern Asia. It is a perennial forb with a short caudex attached to a woody taproot. It is non-rhizomatous and does not form monospecific stands but it can be dense. Sulphur cinquefoil has no known mycorrhizal associations. It reproduces by seed and vegetatively by sprouting from a caudex. Cross fertilization (cross pollinated by wind or insects) is the most common means of fertilization but some seeds are produced by self-pollination. Sulphur cinquefoil is most common on disturbed areas but can invade relatively undisturbed sites. Generally more abundant on drier sites with less total grass cover. Sulphur cinquefoil is also intolerant of complete shade. Survival of plant parts depends on depth of burial and fire severity as perennating buds in the caudex can survive fire if not exposed to lethal temperatures. Sulphur cinquefoil likely resprouts following fire and establishes from on-site or off-site seed. Fall or spring fire did not have a long term impact on Sulphur cinquefoil at Dancing Prairie in northwestern Montana. It did not result in mortality of large plants, but did reduce the density of small plants immediately after burning for one year and enhanced germination however the seedling survival depended on sufficient moisture. The Dancing Prairie is dominated by C3 plants and dormant season and late fall burns are more likely to harm nonnative, invasive plant populations without damaging native species, while late-spring and early-fall burns are more detrimental to native species.

State and transition model

Ecosystem states

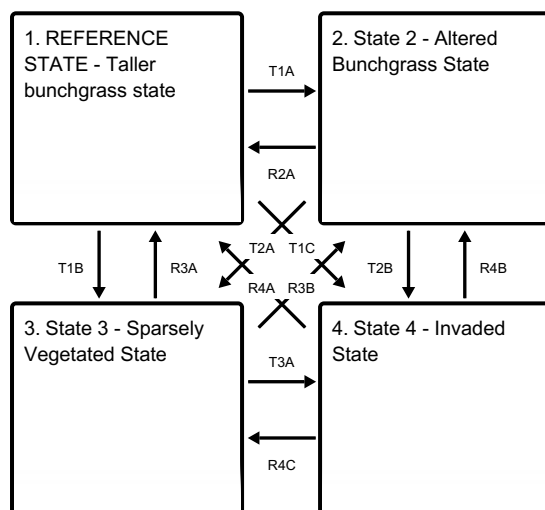

T1A - Overgrazing, Soil Erosion

T1B - Introduction of Weedy Propagules, Overgrazing

T1C - Introduction of weedy seed propagules, establishment of weedy species and resultant dominance of weed species to native plant species.

R2A - Mechanical Brush Management, Range Seeding

T2A - Introduction of Weedy Propagules, Fire

T2B - Introduction of Weedy Propagules

R3A - Proper Grazing Management, Range

T3A - Introduction of Weedy Propagules

R4A - Weed Management, Range Seeding

R4B - Weed Management, Woody Propagules

R4C - Weed Management, Wood Propagules Not Present

State 1 submodel, plant communities

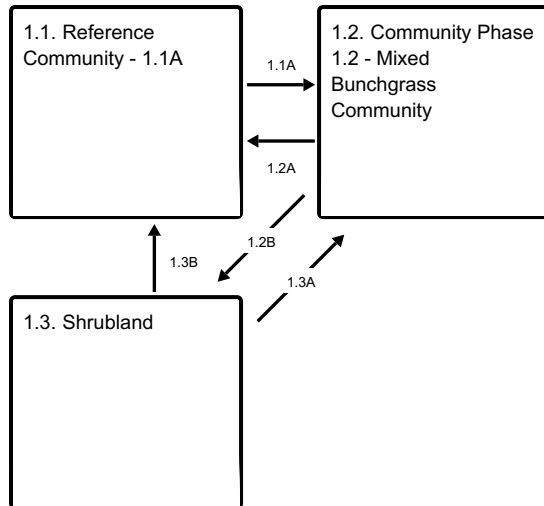

1.1A - Lack of Fire, Improper Grazing Management

1.2A - Fire, Proper Grazing Management

1.2B - Lack of Fire, Improper Grazing Management

1.3B - Fire, Proper Grazing Management

1.3A - Fire, Proper Grazing Management

State 2 submodel, plant communities

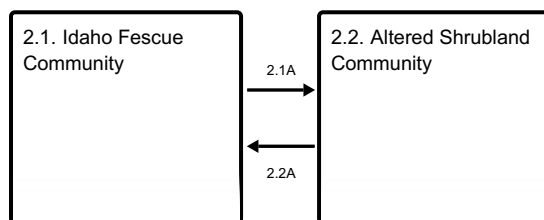

2.1A - Improper Grazing Management, Soil Erosion

2.2A - Proper Grazing Management

State 3 submodel, plant communities

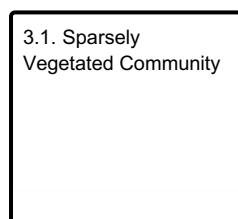

State 4 submodel, plant communities

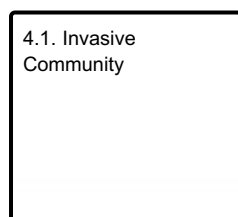

State 1

REFERENCE STATE - Taller bunchgrass state

This state is characterized by cool-season bunchgrasses and is represented by three communities that differ mainly in the percent composition rough fescue and Idaho fescue (*Festuca idahoensis*) and bluebunch wheatgrass and presence of shrub species.

Community 1.1
Reference Community - 1.1A



Figure 9. A Loamy Steep ecological site with minimal weedy species present.



Figure 10. Another site of the Loamy Steep ecological site but with higher weedy species cover.

Rough fescue 30 to 70 percent Idaho fescue and Bluebunch wheatgrass subdominant Woody canopy cover less than 10 percent Rough fescue (*Festuca campestris*)-(Idaho fescue (*Festuca idahoensis*)-prairie junegrass (*Koeleria macrantha*)-bluebunch wheatgrass (*Pseudoroegneria spicata*)/ stiff yellow Indian paintbrush (*Castilleja lutescens*)-silky lupine (*Lupinus sericea*)-blanketflower (*Gaillardia aristata*). Production is high for this community averaging 2100 pounds per acre, ranging from 2050 to 3000 pounds per acre. In general, the proportion of total community composition is 80 percent grass (70 percent cool season bunchgrasses and 10 percent shortgrasses), 10 percent forb and 10 percent shrub species. canopy cover (average)" SPECIES/frequency/AVERAGE ACMI2 2 7.0 ANRO2 1 5.0 ARSO2 2 5.0 ASLO4 1 2.0 ASMI9 1 3.0 BASA3 1 5.0 BRIN2 1 10.0 CAAP 1 2.0 CALU14 2 11.0 CAPR5 1 0.1 CARO2 1 5.0 CIUN 1 2.0 CRIN4 1 1.0 ERFI2 2 3.0 ERUM 1 3.0 FECA4 2 37.5 FEID 2 17.5 GAAR 2 6.0 GABO2 2 4.0 GETR 2 4.0 HECO26 1 5.0 HYSCS2 1 0.1 KOMA 2 10.0 LIPE2 1 1.0 LIRU4 2 5.0 LUSE4 2 8.5 LUPIN 1 10.0 NAVI4 1 0.1 PECO6 1 5.0 PHPR3 1 5.0 POGR9 1 0.1 POPR 1 5.0 PSSP6 2 7.5 ROWO 1 5.0 STIPA 1 0.1 SYAL 1 0.1 TRGR7 1 0.1 FOLIAR COVER (AVERAGE): Species Scientific Common Foliar Cover % Basal Cover % FECA4 *Festuca campestris* . rough fescue 51.7 5.3 FEID *Festuca idahoensis* Idaho fescue 36.0 2.3 LUSE4 *Lupinus sericea* silvery lupine 11.7 0.0 PSSP6 *Pseudoroegneria spicata* bluebunch wheatgrass 11.3 1.3 KOMA *Koeleria macrantha* prairie Junegrass 8.7 0.3 ACMI2 *Achillea millefolium* common yarrow 6.3 0.0 LIRU4 *Lithospermum ruderale* western stoneseed 5.3 0.0 POPR *Poa pratensis* . Kentucky bluegrass 5.3 0.0 GETR *Geum triflorum* old man's whiskers 3.7 0.3 ACNE9 *Achnatherum nelsonii* Columbia needlegrass 3.3 0.0 ROWO *Rosa woodsii* . Woods' rose 3.3 0.0 ASLO4 *Astragalus lotiflorus* . lotus milkvetch 2.7 0.0 GABO2 *Galium boreale* . northern bedstraw 2.7 0.0 CALU14 *Castilleja lutescens* stiff yellow Indian paintbrush 2.0 0.0 PHHO *Phlox hoodii* spiny phlox 1.3 0.3 GAAR *Gaillardia aristata* blanketflower 1.0 0.0 CAAP *Calochortus apiculatus* pointedtip mariposa lily 0.7 0.0 PECO6 *Penstemon confertus* yellow penstemon 0.7 0.0 ANMA *Anaphalis margaritacea* . western pearly everlasting 0.3 0.0 ANRO2 *Antennaria rosea* rosy pussytoes 0.3 0.0 ARSO2 *Arnica sororia* twin arnica 0.3 0.0 CARO2 *Campanula*

rotundifolia . bluebell bellflower 0.3 0.0 ERF12 *Erigeron filifolius* threadleaf fleabane 0.3 0.0 Community Phase Name: Reference Plant Community – Taller Bunchgrass Community The Taller Bunchgrass Community (1.1) is dominated by rough fescue, (a taller cool-season bunchgrass) with a minor component of forb and low-shrubs. Rough fescue heavily dominates the production, canopy and foliar cover of the site. Other grass species occurring in moderate cover include prairie junegrass, Idaho fescue and bluebunch wheatgrass. Grass species with trace cover include needle and thread grass, green needlegrass. On the drier climatic end of this ecological site, bluebunch wheatgrass can occur with Idaho fescue for 10 to 40 percent of canopy cover. Subshrub species that occur in low canopy cover include rosy pussytoes and parsnipflower buckwheat (*Eriogonum heracleoides*). Shrubs that occur in low cover include Wood's rose (*Rosa woodsii*) and common snowberry (*Symphoricarpos albus*). Forbs that occur frequently but in low cover are blanketflower (*Gaillardia aristata*), silky lupine (*Lupinus sericea*) and stiff yellow Indian paintbrush (*Castilleja lutescens*). Other forb species present are yarrow (*Achillea millefolia*), twin arnica (*Arnica sororia*), lotus milkvetch (*Astragalus lotiflorus*), timber milkvetch (*Astragalus miser*), arrowleaf balsamroot (*Balsamorhiza sagittata*), pointedtip mariposa lily (*Calochortus apiculatus*), bluebell bellflower (*Campanula rotundifolia*), wavyleaf thistle (*Cirsium undulatum*), limestone hawkbeard (*Crepis intermedia*), threadleaf fleabane (*Erigeron filifolius*), northern bedstraw (*Galium boreale*), old man's whiskers (*Geum triflorum*), Scouler's St. Johnswort (*Hypericum scouleri*), slender cinquefoil (*Potentilla gracilis*), largeflower triteleia (*Triteleia grandiflora*), littleflower penstemon (*Penstemon procerus*) and western stoneseed (*Lithospermum ruderales*). Production is high for this community averaging 2100 pounds per acre, ranging from 2050 to 3000 pounds per acre. In general, the proportion of total community composition is 80 percent grass (70 percent cool season bunchgrasses and 10 percent shortgrasses), 10 percent forb and 10 percent shrub species. The dataset taken in Tobacco Valley for the Loamy Steep ecological site had grass species as about 76 percent of composition, while forb species are 22 percent and shrub species 1 percent. For cool season bunchgrasses, rough fescue comprises about 32 percent of composition, Idaho fescue about 23 percent and bluebunch wheatgrass 20 percent composition. The foliar cover is very high at this site (99 percent), total litter is high (92 percent) and bare ground is only a trace. The soil surface is dominated by embedded litter, moderate moss cover (14 percent) and low soil cover (7 percent). The basal hits are only 10 percent, but it is generally thought that this should be higher about 20 percent. The Taller Bunchgrass State generally occurs on the Loamy Steep site in areas where proper grazing management practices have been implemented over a long period. The Taller Bunchgrass Community can be maintained through the implementation of properly managed grazing that provides adequate growing-season deferment to allow establishment of taller grass propagules and/or the recovery of vigor of stressed plants.

Resilience management. The Taller Bunchgrass Community (1.1) in general is resistant to change with proper grazing management and near normal precipitation. However, rough fescue will decrease in vigor and decline in species composition under continuous season-long grazing. Subdominant species, such as Idaho fescue, tolerate higher grazing pressure and may increase in cover under prolonged drought conditions. This increase drives the community shift to the Mixed Bunchgrass Community (1.2). The Taller Bunchgrass Community (1.1) is moderately resilient to shrub invasion if properly managed. However, improper grazing will decrease the vigor of desirable grass species and result in an increase in shrub canopy. There will be a notable increase in less desirable plants such as Idaho fescue and shortgrasses. When this occurs the Taller Bunchgrass Community (1.1) will shift to a Mixed Bunchgrass Community (1.2). Once the ecological site becomes dominated by Idaho fescue it will transition to the Altered State (2). Periodic fire increases the resilience of the Taller Bunchgrass Community (1.1) by reducing competition and canopy cover of woody species. Fire also removes decadent herbaceous material, particularly from taller bunchgrasses, which promotes increased vigor and seedling establishment. Timing and intensity of a fire are critical components that can have varying positive or negative effects on this plant community. Fire does increase risk of invasion from invasive species, most notably cheatgrass. At least two growing seasons of rest are recommended to allow plants to recover after fire. Without fire and/or brush control, woody species on the site will increase and the site will shift to the Shrubland Community (1.3). This can occur with or without the degradation of the herbaceous community from rough fescue dominated to a community dominated by Idaho fescue. If degradation of the herbaceous component does occur, the site will transition to the Altered State (2). Because the woody species that dominate in the Shrubland Community (1.3) are native species in the Taller Bunchgrass State, the shift to the Shrubland Community is a linear process with shrubs starting to increase soon after fire or brush control ceases. Heavy continuous grazing will reduce plant cover, litter, and mulch. Bare ground will increase and expose the soil to erosion. Litter and mulch will move off-site as plant cover declines. When canopy cover decreases to below 50 percent the surface horizon becomes less stable and erosion can occur. This will make it more difficult to reestablish rough fescue plants due to decreased soil fertility. When overgrazing continues, invasive weedy grass and forb species move into the plant community and the site transitions to the Altered State (2), Sparsely Vegetated State (3) or the Invaded State (4). Until the Taller Bunchgrass Community (1.1) crosses the threshold into the Altered State (2.1), Sparsely Vegetated Community (3.1) or the Invaded Community (4.1), this

community can be managed back toward the Taller Bunchgrass Community (1.1) using management practices including prescribed grazing, prescribed burning, and strategic weed control. It may take several years to achieve this state, depending upon the climate and the aggressiveness of the treatment. While the Taller Bunchgrass Community (1.1) is resilient to degradation under proper management, the community remains at risk of invasion by aggressive non-native species because of the ability of spotted knapweed, leafy spurge, and cheatgrass to invade healthy rangelands and the widespread presence of propagules. Healthy plant communities are most resilient to invasives although many examples exist of well-managed areas that have been invaded by spotted knapweed. Invasives impact plant communities even if the site does not yet have a critical population of invasives. Almost all reference sites had at least trace amounts of spotted knapweed and/or cheatgrass. It is believed that most sites with only trace amounts have been chemically treated for invasives at some point. These treatments would have impacted other broad-leafed species (forbs and shrubs). It is likely that this site had more potential for forb and shrub production than found on current reference sites. The natural fire regime would have favored an increase in forbs while maintaining shrubs as a very minor component. Rock cover on the soil surface is minimal and does impact productivity of this site. Plant basal cover is expected to be about 20 percent and bare ground is expected to be between 5 and 10 percent. The soils of this site have high soil stability values. There should be no signs of current erosion occurring on the site.

Table 5. Annual production by plant type

Plant Type	Low (Lb/Acre)	Representative Value (Lb/Acre)	High (Lb/Acre)
Grass/Grasslike	1638	1696	2395
Forb	205	212	299
Shrub/Vine	205	212	299
Tree	0	0	0
Total	2048	2120	2993

Community 1.2

Community Phase 1.2 - Mixed Bunchgrass Community

Community Phase Name: Mixed Bunchgrass Community Community Phase Narrative: This community is dominated rough fescue and subdominated by Idaho fescue with moderate overstory common snowberry. Common snowberry and Idaho fescue increase in species composition when rough fescue decreases due to improper grazing management and lack of fire and brush control. Rough fescue will have lower relative production and lower total production than in the Taller Bunchgrass Community (1.1). Bluebunch wheatgrass is subdominant. Other subdominant grass species that are more tolerant to grazing are likely to increase include Sandberg bluegrass (*Poa secunda*) needleandthread (*Hesperostipa comata*), prairie junegrass (*Koeleria macrantha*) and Kentucky bluegrass (*Poa pratensis*). Some increaser forbs species may include silky lupine (*Lupinus sericeus*), field chickweed (*Cerastium arvense*), ballhead sandwort (*Arenaria congesta*), northern bedstraw (*Galium boreale*) and pussytoes (*Antennaria* spp.). Fringed sagewort, Woods' rose (*Rosa woodsii*) and common snowberry (*Symphoricarpos albus*) are shrubs that also increase under prolonged drought or heavy grazing.

Resilience management. Heavy continuous grazing will reduce plant cover, litter, and mulch. Bare ground will increase and expose the soil to erosion. Litter and mulch will move off-site as plant cover declines. As long as the canopy cover remains greater than 50 percent and production of rough fescue and bluebunch wheatgrass is greater than 10 percent of total biomass production, the site can return to the Taller Bunchgrass Community (Pathway 1.2A). The Mixed Bunchgrass (1.2) and the Shrubland Community (1.3) are "At-Risk" Communities. The transition to the Altered State can occur from any community within the Taller Bunchgrass State (1), it is not dependant on an increase of woody canopy cover, but on the decrease of rough fescue and bluebunch wheatgrass composition to less than 10 percent. When overgrazing continues, increaser species such as Sandberg and native forb species will become more dominant and this triggers the transition from the Taller Bunchgrass State (1). Fire and/or brush control can be used to maintain the site in the Taller Bunchgrass State (1) as long as rough fescue production does not fall below 10 percent. Until the Mixed Bunchgrass Community (1.2) crosses the threshold into the Altered State (2.0), this community can be managed back toward the Taller Bunchgrass Community (1.1) using management practices including prescribed grazing combined with prescribed burning and strategic brush control. It may take several years to make this shift, depending upon weather and aggressiveness of grazing management and brush treatment. Fire can be used to control smaller shrubs and trees. Chemical or mechanical treatment of larger shrubs

and trees may be necessary in older stands. Without any form of brush control, woody species continue to increase in canopy cover. Once woody canopy exceeds approximately 20 percent and attains reproductive capability, a shift to the Shrubland Community (1.3) has occurred.

Community 1.3 Shrubland

Community Phase Narrative: The Shrubland Community (1.3) is characterized by greater than 20 percent woody canopy cover with rough fescue in the understory. Once woody canopy cover reaches 20 percent, the site will begin to take on the appearance of a shrubland. Rough fescue may remain dominant in the understory or share dominance with Idaho fescue. Without fire, woody canopy cover increases and the Mixed Bunchgrass Community (1.2) shifts to the Shrubland Community (1.3). The dominant shrub species is common snowberry, and the understory is dominated by Idaho fescue. Other shrub and tree species include Woods' rose (*Rosa woodsii*), fringed sagewort (*Artemisia frigida*), Douglas-fir (*Pseudotsuga menziesii*), and ponderosa pine (*Pinus ponderosa*). The Shrubland Community (1.3) differs from the Altered Shrubland Community (2.2) in the amount of degradation present in the understory. Under proper grazing management, the herbaceous component will be dominated by rough fescue. As long as rough fescue has not fallen below 10 percent species composition, the Shrubland Community (1.3) can be managed back to the Taller Bunchgrass Community (1.1) using prescribed grazing and strategic weed control. It may take several years to achieve this recovery, depending on growing conditions, vigor of remnant rough fescue plants, and the aggressiveness of the weed treatments. With improper grazing management, rough fescue will decline and less palatable grass species, such as Idaho fescue and forb species will dominate understory and the site transitions to the Altered State (2).

Pathway 1.1A Community 1.1 to 1.2

Community Phase Pathway 1.1A Rough fescue loses vigor when overgrazed. When vigor declines enough for plants to die or become smaller, species with higher grazing tolerance (most often Idaho fescue) increase in vigor and production as they use the resources previously used by rough fescue and bluebunch wheatgrass. Decrease of species composition by weight of rough fescue to less than 50 percent indicates that the plant community has shifted to the Mixed Bunchgrass Community (1.2). The driver for this community pathway 1.1A is improper grazing management. The trigger for this shift is the loss of vigor of rough fescue.

Pathway 1.2A Community 1.2 to 1.1

Community Phase Pathway 1.2A The Mixed Bunchgrass Community (1.2) will return to the Taller Bunchgrass Community (1.1) with proper grazing management that provides sufficient critical growing season deferment in combination with proper grazing intensity. Favorable moisture conditions will facilitate or accelerate this transition. The driver for this community shift (1.2A) is the increase in vigor of rough fescue to the point that it represents more than 50 percent of species composition. The trigger for this shift is the change in grazing management that favors rough fescue.

Pathway 1.2B Community 1.2 to 1.3

Community Phase Pathway 1.2B Shrubs make up a portion of the plant community in the Taller Bunchgrass Community (1.1), hence woody propagules are present. Therefore, the Taller Bunchgrass State is always at risk for shrub dominance and a shift to the Shrubland Community (1.3) in the absence of fire and brush management. The drivers for Community Phase Pathway (1.2B) are overgrazing and lack of fire and/or brush control. The mean fire return interval in the Taller Bunchgrass State is likely less than 35 years. Even with proper grazing and favorable climate conditions, lack of fire or brush control for 20 years will allow shrubs and trees to increase in canopy to reach the 20 percent threshold level.

Pathway 1.3B Community 1.3 to 1.1

Community Phase Change Pathway 1.3B The Shrubland Community can return to the Taller Bunchgrass Community after a fire as long as the understory is able to carry the fire and rough fescue crowns survive the fire and re-sprout and/or there is sufficient seed for rough fescue to re-vegetate the area.

Pathway 1.3A Community 1.3 to 1.2

Community Phase Change Pathway 1.3A The Shrubland Community can return to the Mixed Bunchgrass Community after a fire as long as the understory is able to carry the fire and rough fescue crowns survive the fire and re-sprout and/or there is sufficient seed for rough fescue to re-vegetate the area.

State 2 State 2 - Altered Bunchgrass State

This state is characterized by having < 10% rough fescue and < 50% canopy cover. State 2 is represented by two communities that differ in the percent composition of Idaho fescue, production, and soil degradation. Production in this state is considerably lower than in the Taller Bunchgrass State (1). Some native plants tend to increase under prolonged drought and/or heavy grazing practices. A few of these species include Idaho fescue, needleandthread, Sandberg bluegrass, silky lupine, field chickweed, ballhead sandwort, common snowberry, Wood's rose and fringed sagewort.

Community 2.1 Idaho Fescue Community

Community Phase Number: 2.1 Community Phase Name: Idaho fescue Community Community Phase Narrative: The Idaho Fescue Community (2.1) is characterized by an herbaceous component dominated by Idaho fescue with rough fescue being less than 10 percent of species composition by dry weight. This makes it difficult for rough fescue to increase with simply a change in grazing management alone. This community may or may not have a shrub component with canopy cover up to 20 percent. If a shrub component is present, it will be dominated by common snowberry. The Idaho Fescue Community tends to occur if the forage component has been degraded but fire or brush control has kept the shrub community to less than 20 percent cover. This community is at risk of shifting to the Altered Shrubland Community (2.2) if without fire or other brush control. This shift can be accelerated when improper grazing management occurs. This most often happens when stocking rates are not adjusted to compensate for the decrease in forage production as shrub production increases. Canopy cover decreases compared to the Shrubland Community (1.2) to below 50 percent. Wind and water erosion may be eroding soil from the plant interspaces. Soil fertility is reduced, soil compaction is increased, and resistance to soil surface erosion has declined compared to the Taller Bunchgrass State (1).

Community 2.2 Altered Shrubland Community

Community Phase Number: 2.2 Community Phase Name: Altered Shrubland Community Community Phase Narrative: The Altered Shrubland Community (2.2) is characterized by greater than 20 percent woody canopy cover with Idaho fescue or shortgrasses in the understory. It has the appearance of shrub dominance with a degraded understory. The overstory is similar to the Shrubland Community (1.3) in the Taller Bunchgrass State (1). Common snowberry typically dominates the shrub component. If long-term lack of fire and heavy grazing continues, the Idaho Fescue Community (2.1) shifts to the Altered Shrubland Community (2.2) because of the increase in shrubs. The understory in the community can vary from a community with a grass component dominated by Idaho Fescue to an understory dominated by forbs and shortgrasses. Failure to adjust stocking rate as shrub cover increases results in further degradation of the herbaceous community causing an increase in bare ground between shrubs. At its most extreme this community can have a dense canopy of shrubs with sparse understory making the site difficult to return to a higher condition community even if brush is removed. Reseeding and other cultural practices may be needed. When overgrazing continues, invasive grass and forb species move into the plant community and the site can transition to the Sparsely Vegetated State (3) or the Invaded State (4). Until the Altered Shrubland Community (2.2) crosses the threshold into the Sparsely Vegetated State (3) or the Invaded State (4) this community can be managed toward the Idaho Fescue Community (2.1) using prescribed grazing and strategic weed control.

Pathway 2.1A

Community 2.1 to 2.2

Community Phase Pathway 2.1A The Altered State is always at risk for shrub dominance and a shift to the Altered Shrubland Community (2.2) in the absence of fire and brush management. The drivers for Community Shift 2.1A are overgrazing and lack of fire and/or brush control. The mean fire return interval in the Altered State is likely less than 35 years. Even with proper grazing and favorable climate conditions, lack of fire or brush control for 20 years will allow shrubs and trees to increase in canopy to reach the 20 percent threshold level. Improper grazing, prolonged drought, and a warming climate will provide a competitive advantage to shrubs, which will accelerate this process. The driver for this community shift is improper grazing management in combination with lack of fire and/or brush control.

Pathway 2.2A

Community 2.2 to 2.1

Community Phase Pathway 2.2A The Altered Shrubland Community (2.2) can return to the Idaho Fescue Community (2.1) after a fire as long as the understory is able to carry the fire and Idaho fescue crowns survive the fire and re-sprout and/or there is sufficient seed Idaho fescue to re-vegetate the area.

State 3

State 3 - Sparsely Vegetated State

Community Phase Narrative: Long-term grazing mismanagement with continuous growing-season pressure will reduce total productivity of the site and lead to an increase of bare ground. Once plant cover is reduced, the site is more susceptible to erosion. Soil erosion reduces soil fertility creating a reduction in plant production. This soil erosion or loss of soil fertility indicates the transition to the Sparsely Vegetated State (3). The decline may be exacerbated by extended drought conditions. Very sparse plant cover and soil surface erosion characterize this community. Grass and forb, and shrub cover may be very sparse or clumped (canopy cover less than 25 percent). Weeds, annual species, or shortgrass species dominate the plant community. Mid-stature perennial bunchgrass species (e.g., needleandthread) may exist, but only in patches. Compared to the Taller Bunchgrass State (1) and the Altered State (2), this community has crossed a threshold (T1B, T2A) because of soil erosion, loss of soil fertility, or degradation of soil properties. If further soil erosion occurs, there will be a critical negative shift in the ecological processes of this site. The affects of soil erosion can alter the hydrology, soil chemistry, soil microorganisms, and soil physics to the point where intensive restoration is required to restore the site to another state or community. Simply changing grazing management cannot create sufficient change to restore the site within a reasonable period. It will require a considerable input of energy to move the site back to the Taller Bunchgrass State (1). This state has lost soil or vegetation attributes to the point that recovery to the Taller Bunchgrass State (1) will require reclamation efforts, i.e., soil rebuilding, intensive mechanical treatments, and/or reseeding. In this community phase there may be a significant amount of bare ground, and large gaps may occur between plants. The transition to this state could occur because of overgrazing (often because of failure to adjust stocking rates in response to declining forage production because of increased dominance of unpalatable invasive species), long-term lack of fire, warming climate, or extensive drought. Potential exists for soils to erode to the point that irreversible damage may occur. If herbaceous cover decreases to the point that soils are no longer stable, the shrub overstory may not prevent soil erosion. This plant community may be in a terminal state that will not return to the reference state because of degraded soil properties and loss of higher successional native plant species.

Community 3.1

Sparsely Vegetated Community

Short grass or forb species dominate the community Degraded soil properties

State 4

State 4 - Invaded State

The Invaded State (4) is characterized by greater than 25 percent of invasive species: spotted knapweed, leafy spurge, sulphur cinquefoil, and/or cheatgrass are the dominant invasive species in MLRA 44A. Introduced exotic plant species have been identified as one of the greatest threats to the integrity and productivity of native rangeland

ecosystems and conservation of indigenous biodiversity (DiTomaso 2000; Mack et al. 2000). In addition to environmental consequences, damages caused and costs incurred to control invasive plants are several billion dollars each year in the United States (Pimentel et al. 2000).

Community 4.1 Invasive Community



Figure 12. A Loamy Steep ecological site that has high weedy species cover.

Invasive species greater than 25 percent including spotted knapweed, cheatgrass and other invasives

Resilience management. Invasives are the driving factor throughout western Montana and they are a focal part of the ecology of MLRA 44A. Their ability to take over and dominate a site has become a big concern. Improper grazing management has contributed to the spread of these species. The potential for altered ecosystem structure and function is high in the Invaded State (4) and can occur in many ways. The increase in invasive species, especially noxious weeds, can lead to reduction of the native bunchgrasses and an increase in the proportion of bare ground, which often results in reduced infiltration rates and increased surface runoff and erosion. Invasion by cheatgrass reduces above and below ground biomass (Ogle et al. 2003), increases plant litter, changes plant community canopy architecture (Belnap and Phillips 2001), reduces soil biota richness and abundance, reduces plant community richness (Belnap et al. 2005), increases wildfire frequency (Whisenant 1990), and potentially facilitates invasion by other noxious or invasive plants. Dense populations of invasive species can cause soil loss to increase because of lack of surface cover (Lacey et al. 1989). Early in the invasion process there is a lag phase where invasive plant populations remain small and localized before expanding exponentially (Hobbs and Humphries 1995). Based on research conducted in noxious weed-invaded plant communities in Montana, it is reasonable to estimate that 25 percent dry weight composition of invasive plant species is the point in the invasion process where spread and abundance is increasing exponentially and where a plant community has crossed a threshold (Masters and Sheley 2001). For aggressive invasive species (i.e., spotted knapweed), this threshold could be less than 10 percent. Once invasive species dominate the site, either in species composition by weight or in their impact on the community, the threshold has been crossed to the Invaded State (4). Once invasive species such as spotted knapweed, cheatgrass, and leafy spurge become established, they are very difficult to eradicate. Therefore, considerable effort should be placed in preventing plant communities from crossing a threshold to the Invaded State (4) through early detection and proper management. Preventing new invasions is by far the most cost-effective control strategy and typically places an emphasis on education. Control measures used on the noxious plant species impacting this ecological site include chemical, biological, and cultural control methods. The best success has been found with an integrated weed management strategy that incorporates one or several of these options along with education and prevention efforts (DiTomaso 2000). Production in the invaded community may vary greatly. A site dominated by spotted knapweed, where soil fertility and chemistry remain near potential, may have production near that of the reference community. A site with degraded soils and infestation of cheatgrass may produce only 10 to 20 percent as many pounds per acre as of the reference community. Invasive plant species have effective reproductive strategies, long seed viability in the soil seed bank, and/or allelopathic properties (Williamson and Fitter 1996). Spotted knapweed has allelopathic properties whereby its roots exude catechin, which may limit the growth and establishment of other plant species (Callaway and Vivanco 2007; Bais et al. 2002), thus promoting its own success. An in-vitro experiment showed that other weeds like Dalmatian toadflax (*Linaria dalmatica*), kochia (*Kochia scoparia*), diffuse knapweed (*Centaurea diffusa*), and crops, such as wheat (*Triticum aestivum*), showed mortality on the fourteenth day after addition of root exudates from spotted knapweed (Bais et al. 2002). This

allelopathic property creates highly resilient communities. Cheatgrass has the ability to establish rapidly and attain community dominance following disturbances such as wildfire (Young and Evans 1978) or other disturbances that create bare soil. Cheatgrass is a successful invader because it has the ability to respond rapidly to increases in resource availability (Norton et al. 2004; Lowe et al. 2003) as well as to compete for water (Pellant 1996). Cheatgrass was introduced into the United States in packing materials, ship ballast, and likely as a contaminant of crop seed. Cheatgrass was first found in the United States near Denver, Colorado, in the late 1800s. In the late 1800s and early 1900s, cheatgrass spread explosively in the ready-made seedbeds prepared by the trampling livestock hooves of overstocked rangelands. Cheatgrass has developed into a severe weed in several agricultural systems throughout North America, particularly western pastureland, rangeland, and winter wheat fields (NRCS 2009). Today, cheatgrass is found in most of the western states having reached its range of current distribution by 1930. In fact, a survey of 11 western states showed that cheatgrass was present on at least 60 million acres (Pellant 1996). After arriving in 1893 on the San Juan Islands in Washington, spotted knapweed had established in over 24 counties in three northwestern states by 1924, with several large infestations near Missoula, Montana (Sheley et al. 2005). By 1975, spotted knapweed had spread into most of the western counties of Montana, and today, it is found in every county in Montana. Leafy spurge, a native to Eurasia, was sighted in Park County, Montana as early as 1925 and has since been found in every county in Montana. Overgrazing by livestock has contributed to the spread of leafy spurge (Sheley et al. 2005).

Transition T1A

State 1 to 2

Transition T1A The Taller Bunchgrass State (1) transitions to the Altered State (2) if rough fescue falls below 10 percent species composition. The trigger for this transition is the loss of taller bunchgrasses, which creates a shift in species composition towards lower productive species, especially Idaho fescue. This transition can occur from any community within the Taller Bunchgrass State (1), it is not dependent on an increase of woody canopy cover, but on the decrease of rough fescue production. The driver for this transition is improper grazing management and/or long-term drought leading to a decrease in rough fescue composition to less than 10 percent.

Transition T1B

State 1 to 3

Transition T1B The Taller Bunchgrass State (1) transitions to the Sparsely Vegetated State (3) if plant canopy cover declines to less than 25 percent or and rough fescue decreases to below 10 percent by dry weight. The trigger for this transition is the loss of taller bunchgrasses, which creates open spots of bare soil. Soil erosion is accompanied by decreased soil fertility driving the transitions to the Sparsely Vegetated State. There are several other key factors signaling the approach of transition T1B: increases in soil physical crusting, decreases in cover of cryptogamic crusts, decreases in soil surface aggregate stability and/or evidence of erosion including water flow patterns, development of plant pedestals, and litter movement. The driver for this transition is improper grazing management and/or long-term drought leading to a decrease in rough fescue composition to less than 10 percent.

Transition T1C

State 1 to 4

Transition T1C Regardless of grazing management, without some form of weed management (chemical, mechanical, or biological control), the Taller Bunchgrass State (1) can transition to the Invaded State (4) if aggressive invasive species, such as spotted knapweed and cheatgrass are introduced, even if the herbaceous component of the Reference Plant Community (1.1) is thriving. Healthy plant communities are most resilient to invasives. Long-term stress conditions for native species (e.g., overgrazing, drought, and fire) accelerate the process. If populations of invasive species reach critical levels, the site transitions to the Invaded State. The driver for this transition is the presence of aggressive invasive species.

Restoration pathway R2A

State 2 to 1

Restoration Pathway R2A Restoration of the Altered State to the Taller Bunchgrass State requires substantial energy input. The drivers for this restoration pathway are removal of woody species, restoration of native herbaceous species by reseeding rough fescue.

Transition T2A

State 2 to 3

Transition T2A Removal of shrubs without proper grazing management can lead to an increase in bare ground and erosion of the fertile surface horizon and the site can degrade to the Sparsely Vegetated State (3). The driver for this transition is brush management without proper grazing management.

Transition T2B

State 2 to 4

Transition T2B Removal of shrubs can lead to an increase in bare ground. If invasive species are present, bare ground offers opportunity for invasive species to fill open areas, leading to the Invaded State (4). The driver for this transition is brush management in presence of invasive species.

Restoration pathway R3A

State 3 to 1

Restoration Pathway R3A The Sparsely Vegetated State (3) has lost soil or vegetation attributes to the point that recovery to the Taller Bunchgrass State (1) will require reclamation efforts such as soil rebuilding, intensive mechanical treatments, and/or revegetation. The drivers for this restoration pathway are reclamation efforts and proper grazing management. The trigger is restoration efforts.

Restoration pathway R3B

State 3 to 2

Restoration Pathway R3B The Sparsely Vegetated State (3) has lost soil or vegetation attributes to the point that recovery to the Altered State (2) will require reclamation efforts such as soil rebuilding, intensive mechanical treatments, and/or reseeding in recommended areas only. If the reclamation efforts are performed without reseeding rough fescue, under unfavorable climatic conditions, or without proper grazing management, the site will return to the Altered State.

Transition T3A

State 3 to 4

Transition T3A Invasive species can occupy the Sparsely Vegetated State (3) and drive it to the Invaded State (4). The Sparsely Vegetated State is at risk of this transition occurring if invasive propagules are present. The driver for this transition is the presence of critical population levels (greater than 25 percent) of invasive species. The trigger is the presence of propagules of invasive species.

Restoration pathway R4A

State 4 to 1

Restoration Pathway R4A Restoration of the Invaded State (4) to the Taller Bunchgrass State (1) requires substantial energy input. The drivers for this restoration pathway are removal of invasive species, restoration of native bunchgrass species, ongoing management of invasives, and proper grazing management. Without maintenance, invasive species are likely to return (probably rapidly) because of the presence of propagules in the soil and increases in soil disturbance. The drivers for this reclamation pathway are treatments to reduce or remove invasive/noxious species in combination with favorable growing conditions. The trigger is invasive species control.

Restoration pathway R4B

State 4 to 2

Restoration Pathway R4B Weed management without reseeding taller bunchgrasses, favorable climatic conditions, or proper grazing management will lead to the Altered State (2).

Restoration pathway R4C

State 4 to 3

Restoration Pathway R4C If invasive species are removed without sufficient remnant populations of reference community species (particularly rough fescue), a site in the Invaded State (4) is likely to return to the Sparsely Vegetated State (3) instead of the Taller Bunchgrass State (1). The driver for the reclamation pathway is weed management without reseeding. The trigger is invasive species control.

Additional community tables

Table 6. Community 1.1 plant community composition

Group	Common Name	Symbol	Scientific Name	Annual Production (Lb/Acre)	Foliar Cover (%)
Grass/Grasslike					
1	Cool Season			1433–2096	
	rough fescue	FECA4	<i>Festuca campestris</i>	900–1300	–
	bluebunch wheatgrass	PSSP6	<i>Pseudoroegneria spicata</i>	300–700	–
	Idaho fescue	FEID	<i>Festuca idahoensis</i>	300–700	–
2	Shortgrasses/Rhizomatous Grasses			200–299	
	prairie Junegrass	KOMA	<i>Koeleria macrantha</i>	50–200	–
	Sandberg bluegrass	POSE	<i>Poa secunda</i>	50–200	–
Forb					
3	Forbs			200–299	
	common yarrow	ACMI2	<i>Achillea millefolium</i>	60–100	–
	onion	ALLIU	<i>Allium</i>	60–100	–
	lotus milkvetch	ASLO4	<i>Astragalus lotiflorus</i>	60–100	–
	pointedtip mariposa lily	CAAP	<i>Calochortus apiculatus</i>	60–100	–
	stiff yellow Indian paintbrush	CALU14	<i>Castilleja lutescens</i>	60–100	–
	bluebell bellflower	CARO2	<i>Campanula rotundifolia</i>	60–100	–
	parsnipflower buckwheat	ERHE2	<i>Eriogonum heracleoides</i>	60–100	–
	blanketflower	GAAR	<i>Gaillardia aristata</i>	60–100	–
	northern bedstraw	GABO2	<i>Galium boreale</i>	60–100	–
	old man's whiskers	GETR	<i>Geum triflorum</i>	60–100	–
	western stoneseed	LIRU4	<i>Lithospermum ruderale</i>	60–100	–
	silky lupine	LUSE4	<i>Lupinus sericeus</i>	60–100	–
	littleflower penstemon	PEPR2	<i>Penstemon procerus</i>	60–100	–
	spiny phlox	PHHO	<i>Phlox hoodii</i>	60–100	–
Shrub/Vine					
4	Shrubs			200–299	
	common snowberry	SYAL	<i>Symphoricarpos albus</i>	30–50	–
	Woods' rose	ROWO	<i>Rosa woodsii</i>	30–50	–
	mountain snowberry	SYOR2	<i>Symphoricarpos oreophilus</i>	30–50	–

Other references

Aiken, S. G.; Darbyshire, S. J. 1990. Fescue grasses of Canada. Publication 1844/E. Ottawa, ON: Agriculture Canada, Research Branch, Biosystematics Research Centre. 102 p.

Barrett, S. W. 1983. Fire history of Glacier National Park: North Fork Flathead River drainage. Final Report, Supplement No. 22 c2 INT 20. USDA Forest Service, Intermt. For. and Range Exp. Stat., Ogden, Utah.

- Belnap, J., and S. L. Phillips. 2001. Soil biota in an ungrazed grassland: response to annual grass (*Bromus tectorum*) invasion. *Ecological Applications* 11:1261-1275.
- Belnap, J., S. L. Phillips, S. K. Sherrod, and A. Moldenke. 2005. Soil biota can change after exotic plant invasion: does this affect ecosystem processes? *Ecology* 86:3007-3017.
- Callaway, R. M., and J. M. Vivanco. 2007. Invasion of plants into native plant communities using the underground information superhighway. *Allelopathy Journal* 19:143-151.
- Cole, David N. 1987. Effects of three seasons of experimental trampling on five montane forest communities and a grassland in western Montana, USA. *Biological Conservation*. 40: 219-244.
- Coupland, Robert T.; Brayshaw, T. Christopher. 1953. The fescue grassland in Saskatchewan. *Ecology*. 34(2): 386-405.
- Cronquist, Arthur; Holmgren, Arthur H.; Holmgren, Noel H.; Reveal, James L.; Holmgren, Patricia K. 1977. *Intermountain flora: Vascular plants of the Intermountain West, U.S.A. Vol. 6: The Monocotyledons*. New York: Columbia University Press. 584 p.
- Daubenmire, R. 1968a. Soil moisture in relation to vegetation distribution in the mountains of northern Idaho. *Ecology* 49:431-438.
- DiTomaso, J. M. 2000. Invasive weeds in rangelands: Species, impacts, and management. *Weed Science* 48:255-265.
- Eckert, Richard E., Jr.; Spencer, John S. 1987. Growth and reproduction of grasses heavily grazed under rest-rotation management. *Journal of Range Management*. 40(2): 156-159.
- Hanson, A. A. 1959. *Grass varieties in the United States*. Agriculture Handbook No. 170. Washington, DC: U.S. Department of Agriculture, Agricultural Research Service. 72 p.
- Herrick, J. E., J. W. Van Zee, K. M. Havstad, L. M. Burkett, and W. G. Whitford. 2005. *Monitoring manual for grassland, shrubland and savanna Ecosystems. Volume I Quick Start*. USDA - ARS Jornada Experimental Range, Las Cruces, New Mexico.
- Herrick, J. E., J. W. Van Zee, K. M. Havstad, L. M. Burkett, and W. G. Whitford. 2005. *Monitoring manual for grassland, shrubland and savanna Ecosystems. Volume II: Design, supplementary methods and interpretation*. USDA - ARS Jornada Experimental Range, Las Cruces, New Mexico.
- Hill, Janice L., and Karen L. Gray. "Conservation strategy for Spalding's catchfly (*Silene spaldingii* Wats.)." *US Fish and Wildlife*. Boise, Idaho (2004).
- Hobbs, R. J., and S. E. Humphries. 1995. An integrated approach to the ecology and management of plant invasions. *Conservation Biology* 9:761-770.
- Koterba, W. and J. Habeck. 1971. Grasslands of the North Fork Valley, Glacier National Park, Montana. *Can. J. Bot.* 49: 1627-1636.
- Lacey, J. R., C. B. Marlow, and J. R. Lane. 1989. Influence of spotted knapweed (*Centaurea maculosa*) on surface runoff and sediment yield. *Weed Technology* 3:627-631.
- Lackschewitz, Klaus. 1991. *Vascular plants of west-central Montana--identification guidebook*. Gen. Tech. Rep. INT-227. Ogden, UT: U.S. Department of Agriculture, Forest Service, Intermountain Research Station. 648 p.
- Lesica, P., and Cooper, S. V. 1997. *Presettlement vegetation of southern Beaverhead County, Montana*. Unpublished report to the State Office, Bureau of Land Management, and Beaverhead-Deerlodge National Forest. Montana Natural Heritage Program, Helena, MT. 35 pp.

- Masters, R. A., and R. L. Sheley. 2001. Principles and practices for managing rangeland invasive plants. *Journal of Range Management* 54: 502-517.
- Montana Native heritage Program Web Page. Rocky Mountain Foothill, valley grassland. Glacier National Park. Web Page.
- Mueggler, W. F.; Stewart, W. L. 1980. Grassland and shrubland habitat types of western Montana. Gen. Tech. Rep. INT-66. Ogden, UT: U.S. Department of Agriculture, Forest Service, Intermountain Forest and Range Experiment Station. 154 p.
- Nimlos, Thomas J.; Van Meter, Wayne P.; Daniels, Lewis A. 1968. Rooting patterns of forest understory species as determined by radioiodine absorption. *Ecology*. 49(6): 1145-1151.
- NRCS. 2008. National Range and Pasture Handbook. Chapter 3, Section 1, Montana Supplement: Montana Rangeland Ecological Site Key – Version 8.2.
- NRCS. 2009. Plant Guide: Cheatgrass. Prepared by Skinner et al., National Plant Data Center.
- Ogle, S., W. Reiners, and K. Gerow. 2003. Impacts of exotic annual brome grasses (*Bromus* spp.) on ecosystem properties of northern mixed grass prairie. *Am. Midl. Nat* 149:46-58.
- Pavlick, Leon E.; Looman, Jan. 1984. Taxonomy and nomenclature of rough fescues, *Festuca altaica*, *F. campestris* (*F. scabrella* var. *major*) and *F. hallii* in Canada and the U.S. *Canadian Journal of Botany*. 62: 1739-1749.
- Pokorny, M. L., R. L. Sheley, C. A. Zabinski, R. E. Engel, A. J. Svejcar, and J. J. Borkowski. 2005. Plant functional group diversity as a mechanism for invasion resistance. *Restoration Ecology* 13(3): 1-12.
- Ross, R. L., E. P. Murray, and J. G. Haigh. 1973. Soil and vegetation of near-pristine sites in Montana. USDA Soil Conservation Service, Bozeman, MT
- Schoeneberger, P. J., D. A. Wysocki, E. C. Benham, and W. D. Broderson. [Eds.] 2002. Field book for describing and sampling soils, Version 2.0. Natural Resources Conservation Service, National Soil Survey Center, Lincoln, NE. (<http://soils.usda.gov/technical/fieldbook/>)
- Sheley, R. L., B. E. Olson, and C. Hoopes. 2005. Impacts of noxious weeds. Pulling together against weeds. Published by Montana's Statewide Noxious Weed Awareness and Education Program.
- Smith, Michael A.; Busby, Fee. 1981. Prescribed burning: effective control of sagebrush in Wyoming. RJ-165. Laramie, WY: University of Wyoming, Agricultural Experiment Station. 12 p.
- Soil Survey Staff. 2015. Illustrated guide to soil taxonomy. U.S. Department of Agriculture, Natural Resources Conservation Service, National Soil Survey Center, Lincoln, Nebraska.
- Stubbendieck, James; Hatch, Stephan L.; Butterfield, Charles H. 1992. North American range plants. 4th ed. Lincoln, NE: University of Nebraska Press. 493 p.
- Tyser, Robin W. 1990. Ecology of fescue grasslands in Glacier National Park. In: Boyce, Mark S.; Plumb, Glenn E., eds. National Park Service Research Center, 14th annual report. Laramie, WY: University of Wyoming, National Park Service Research Center: 59-60.
- Whisenant, S. G. 1990. Changing fire frequencies on Idaho's Snake River Plains: ecological and management implications. In: McArthur, E. D., E. M. Romney, S. D. Smith, P. T. Tueller. [Eds.] Proceedings of the symposium on cheatgrass invasion, shrub die-off, and other aspects of shrub biology and management. p. 4-10. USFS-INT-GTR-313.

Contributors

Jay Skovlin
Stephanie Shoemaker

Approval

Kirt Walstad, 9/07/2023

Rangeland health reference sheet

Interpreting Indicators of Rangeland Health is a qualitative assessment protocol used to determine ecosystem condition based on benchmark characteristics described in the Reference Sheet. A suite of 17 (or more) indicators are typically considered in an assessment. The ecological site(s) representative of an assessment location must be known prior to applying the protocol and must be verified based on soils and climate. Current plant community cannot be used to identify the ecological site.

Author(s)/participant(s)	
Contact for lead author	
Date	04/19/2024
Approved by	Kirt Walstad
Approval date	
Composition (Indicators 10 and 12) based on	Annual Production

Indicators

1. **Number and extent of rills:**

2. **Presence of water flow patterns:**

3. **Number and height of erosional pedestals or terracettes:**

4. **Bare ground from Ecological Site Description or other studies (rock, litter, lichen, moss, plant canopy are not bare ground):**

5. **Number of gullies and erosion associated with gullies:**

6. **Extent of wind scoured, blowouts and/or depositional areas:**

7. **Amount of litter movement (describe size and distance expected to travel):**

8. **Soil surface (top few mm) resistance to erosion (stability values are averages - most sites will show a range of values):**

-
9. **Soil surface structure and SOM content (include type of structure and A-horizon color and thickness):**
-
10. **Effect of community phase composition (relative proportion of different functional groups) and spatial distribution on infiltration and runoff:**
-
11. **Presence and thickness of compaction layer (usually none; describe soil profile features which may be mistaken for compaction on this site):**
-
12. **Functional/Structural Groups (list in order of descending dominance by above-ground annual-production or live foliar cover using symbols: >>, >, = to indicate much greater than, greater than, and equal to):**
- Dominant:
- Sub-dominant:
- Other:
- Additional:
-
13. **Amount of plant mortality and decadence (include which functional groups are expected to show mortality or decadence):**
-
14. **Average percent litter cover (%) and depth (in):**
-
15. **Expected annual annual-production (this is TOTAL above-ground annual-production, not just forage annual-production):**
-
16. **Potential invasive (including noxious) species (native and non-native). List species which BOTH characterize degraded states and have the potential to become a dominant or co-dominant species on the ecological site if their future establishment and growth is not actively controlled by management interventions. Species that become dominant for only one to several years (e.g., short-term response to drought or wildfire) are not invasive plants. Note that unlike other indicators, we are describing what is NOT expected in the reference state for the ecological site:**
-
17. **Perennial plant reproductive capability:**
-