

Ecological site EX044B01A032

Loamy (Lo) LRU 01 Subset A

Last updated: 9/11/2023
Accessed: 04/24/2024

General information

Provisional. A provisional ecological site description has undergone quality control and quality assurance review. It contains a working state and transition model and enough information to identify the ecological site.

MLRA notes

Major Land Resource Area (MLRA): 044B—Central Rocky Mountain Valleys

Major Land Resource Area (MLRA) 44B, Central Rocky Mountain Valleys, is nearly 3.7 million acres of southwest Montana and borders two MLRAs: 43B Central Rocky Mountains and Foothills and 46 Northern and Central Rocky Mountain Foothills.

The major watersheds of this MLRA are those of the Missouri and Yellowstone Rivers and their associated headwaters such as the Beaverhead, Big Hole, Jefferson, Ruby, Madison, Gallatin, and Shields Rivers. These waters allow for extensive irrigation for crop production in an area that would generally only be compatible with rangeland and grazing. The Missouri River and its headwaters are behind several reservoirs that supply irrigation water, hydroelectric power, and municipal water. Limited portions of the MLRA are west of the Continental Divide along the Clark Fork River.

The primary land use of this MLRA is production agriculture (grazing, small grain production, and hay), but there is some limited mining. Urban development is high with large expanses of rangeland converted to subdivisions for a rapidly growing population.

The MLRA consists of one Land Resource Unit (LRU) and seven climate based LRU subsets. These subsets are based on a combination of Relative Effective Annual Precipitation (REAP) and frost free days. Each subset expresses a distinct set of plants that differentiate it from other LRU subsets. Annual precipitation ranges from a low of 9 inches to a high near 24 inches. The driest areas tend to be in the valley bottoms of southwest Montana in the rain shadow of the mountains. The wettest portions tend to be near the edge of the MLRA at the border with MLRA 43B. Frost free days also vary widely from less than 30 days in the Big Hole Valley to around 110 days in the warm valleys along the Yellowstone and Missouri Rivers.

The plant communities of the MRLA are highly variable, but the dominant community is a cool-season grass and shrub-steppe community. Warm-season grasses have an extremely limited extent in this MLRA. Most subspecies of big sagebrush are present, to some degree, across the MLRA.

LRU notes

MLRA 44B has one LRU that covers the entire MLRA. The LRU has been broken into seven climate subsets based on a combination of Relative Effective Annual Precipitation (REAP) and frost free days. Each combination of REAP and frost free days results in a common plant community that is shared across the subset. Each subset is giving a letter designation of A through F for sites that do not receive additional water and Y for sites that receive additional water.

LRU 01 Subset A has a REAP of nine to 14 inches (228.6-355.6mm) with a frost free days range of 70 to 110 days. This combination of REAP and frost free days results in a nearly treeless sagebrush steppe landscape.

The soil moisture regime is Ustic, dry that borders on Aridic and has a Frigid soil temperature regime.

Classification relationships

Mueggler and Stewart. 1980. Grassland and Shrubland habitat types of Western Montana

1. *Stipa comata/Bouteloua gracilis* h.t.
2. *Agropyron spicatum/Bouteloua gracilis* h.t.

Montana Natural Heritage Program Vegetation Classification

1. *Stipa comata - Bouteloua gracilis* Herbaceous Vegetation (STICOM – BOUGRA) Needle and thread/Blue grama

Natural Heritage Conservation Rank-G5 / S5

Edition / Author- 99-11-16 / S.V. Cooper,

EPA Ecoregions of Montana, Second Edition:

Level I: Northwestern Forested Mountains

Level II: Western Cordillera

Level III: Middle Rockies & Northern Great Plains

Level IV: Paradise Valley

Townsend Basin

Dry Intermontane Sagebrush Valleys

Shield-Smith Valleys

National Hierarchical Framework of Ecological Units:

Domain: Dry

Division: M330 – Temperate Steppe Division – Mountain Provinces

Province: M332 – Middle Rocky Mountain Steppe – Coniferous Forest – Alpine Meadow

Section: M332D – Belt Mountains Section

M332E – Beaverhead Mountains Section

Subsection: M332Ej – Southwest Montana Intermontane Basins and Valleys

M332Dk – Central Montana Broad Valleys

Ecological site concept

The Loamy ecological site is an upland site formed from alluvium or slope alluvium and is on slopes less than 15 percent. The site does not receive additional moisture from a water table or flooding. The soil surface texture ranges from sandy loam to clay loam in surface mineral 4 inches; having less than 32 percent clay. The site is moderately deep to very deep and has no root-restrictive layers within 20 inches (50cm). The surface of the site has less than five percent stone and is not skeletal, with less than 35 percent rock fragments in the 10 to 20-inch depth. The site does not have a saline or saline-sodic influence and is not strongly or violently effervescent within four inches of the mineral surface. Calcium carbonates may increase with depth.

Associated sites

EX044B01A036	Droughty (Dr) LRU 01 Subset A The Droughty ecological site occupies similar landscape position and has a similar plant community.
EX044B01A030	Limy (Ly) LRU 01 Subset A The Limy ecological site tends to occupy slightly convex sites compared to the Loamy, but they are often neighboring sites

Similar sites

EX044B01A036	Droughty (Dr) LRU 01 Subset A The Droughty ecological site differs by being skeletal within 10-20" control section reducing potential production values.
--------------	--

EX044B01A030

Limy (Ly) LRU 01 Subset A

The Limy ecological site differs in that the soil is violent in the surface 4" of mineral soil. The plant community tends to have less sagebrush and expresses slightly lower production potential.

Table 1. Dominant plant species

Tree	Not specified
Shrub	(1) <i>Artemisia tridentata</i>
Herbaceous	(1) <i>Pseudoroegneria spicata</i> (2) <i>Hesperostipa comata</i>

Legacy ID

R044BA032MT

Physiographic features

This ecological site occurs on slopes ranging from 1 to 15 percent however the core concept slopes of this ecological site exist in the 4 to 10 percent range. Parent material is alluvium and slope alluvium of mixed geologic origin.

Table 2. Representative physiographic features

Landforms	(1) Valley > Alluvial fan (2) Valley > Stream terrace (3) Valley > Fan remnant (4) Valley > Eroded fan remnant
Flooding frequency	None
Ponding frequency	None
Elevation	4,000–7,000 ft
Slope	4–10%
Water table depth	42–60 in
Aspect	Aspect is not a significant factor

Table 3. Representative physiographic features (actual ranges)

Flooding frequency	Not specified
Ponding frequency	Not specified
Elevation	Not specified
Slope	1–15%
Water table depth	Not specified

Climatic features

The Central Rocky Mountain Valleys MLRA has a continental climate. Fifty to sixty percent of the annual long-term average precipitation falls between May and August. Average precipitation for LRU A is 12 inches (305 mm), and the frost-free period averages 78 days.

Precipitation is highest in May and June.

Table 4. Representative climatic features

Frost-free period (characteristic range)	70-110 days
Freeze-free period (characteristic range)	110-140 days

Precipitation total (characteristic range)	9-14 in
Frost-free period (actual range)	70-110 days
Freeze-free period (actual range)	110-140 days
Precipitation total (actual range)	9-14 in
Frost-free period (average)	78 days
Freeze-free period (average)	125 days
Precipitation total (average)	12 in

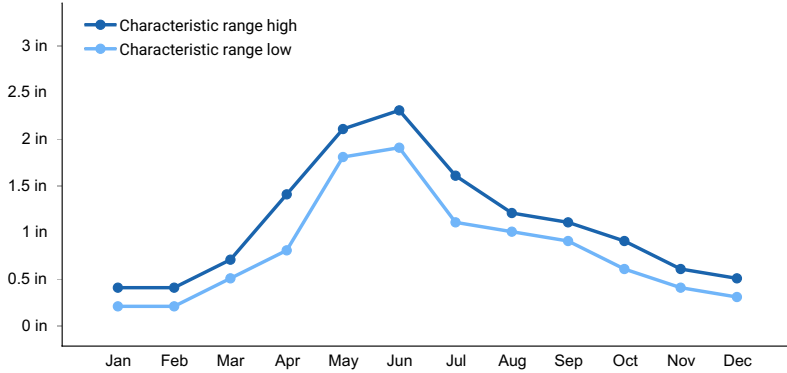

Figure 1. Monthly precipitation range

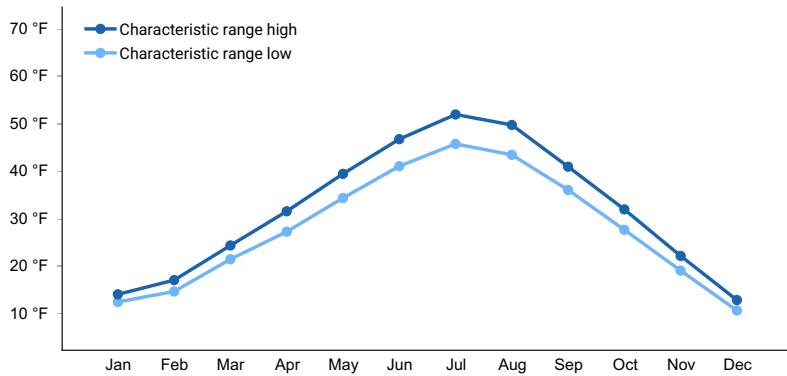

Figure 2. Monthly minimum temperature range

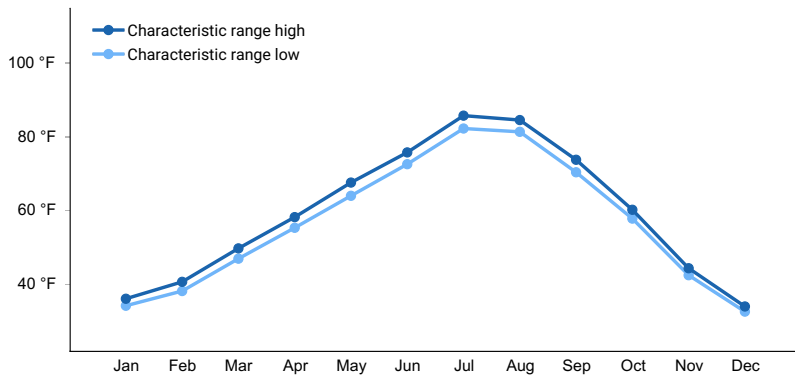

Figure 3. Monthly maximum temperature range

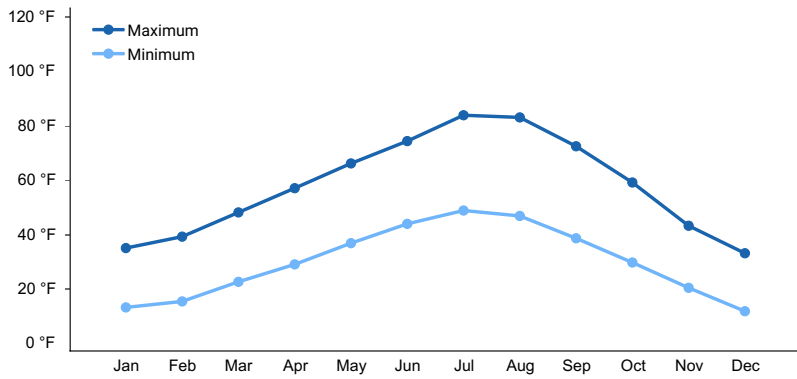

Figure 4. Monthly average minimum and maximum temperature

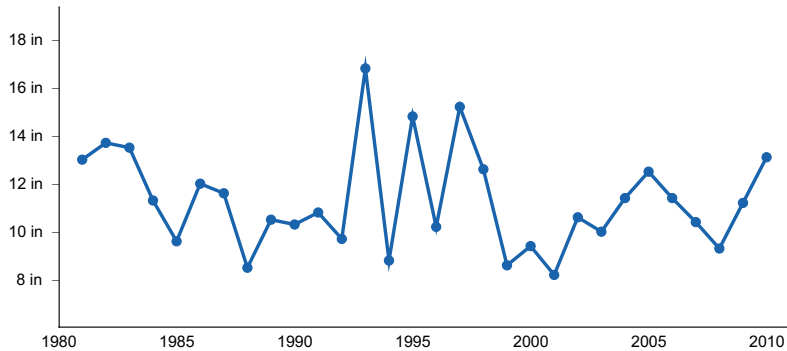

Figure 5. Annual precipitation pattern

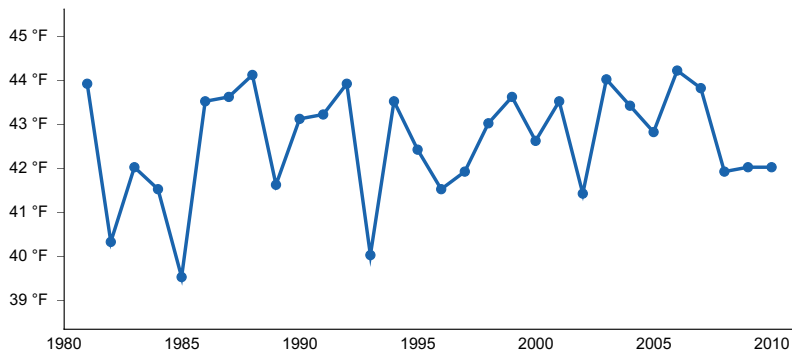

Figure 6. Annual average temperature pattern

Climate stations used

- (1) DEER LODGE 3 W [USC00242275], Deer Lodge, MT
- (2) DILLION U OF MONTANA WESTERN [USC00242409], Dillon, MT
- (3) GLEN 2 E [USC00243570], Dillon, MT
- (4) ENNIS [USC00242793], Ennis, MT
- (5) BOULDER [USC00241008], Boulder, MT
- (6) GARDINER [USC00243378], Gardiner, MT
- (7) TOWNSEND [USC00248324], Townsend, MT
- (8) TRIDENT [USC00248363], Three Forks, MT
- (9) TWIN BRIDGES [USC00248430], Sheridan, MT
- (10) WHITE SULPHUR SPRNGS 2 [USC00248930], White Sulphur Springs, MT
- (11) DILLON AP [USW00024138], Dillon, MT
- (12) HELENA RGNL AP [USW00024144], Helena, MT

Influencing water features

This ecological site is an upland site not associated with current water features.

Wetland description

This site is not associated with wetlands.

Soil features

These soils are moderately deep to very deep, have moderately slow to moderately rapid permeability, and are well drained. These soils are formed from alluvium and slope alluvium. Typically, soil surface textures consist of loam, silt loam, and clay loam textures. Clay content will be less than 32 percent in the surface mineral 4 inches (10 cm). If present, an argillic horizon will have less than 35 percent clay. The common soils series in this ecological site includes Varney and Sappington. These soils may exist across multiple ecological sites due to natural variations in slope, texture, rock fragments, and pH. An onsite soil pit and the most current ecological site key are required to classify an ecological site.

Table 5. Representative soil features

Parent material	(1) Alluvium–igneous, metamorphic and sedimentary rock (2) Slope alluvium–igneous, metamorphic and sedimentary rock
Surface texture	(1) Loam (2) Silt loam (3) Clay loam
Family particle size	(1) Loamy
Drainage class	Moderately well drained to well drained
Permeability class	Slow to moderately rapid
Soil depth	20–60 in
Surface fragment cover <=3"	0–20%
Surface fragment cover >3"	0–15%
Available water capacity (0-40in)	2.6–7.8 in
Calcium carbonate equivalent (0-40in)	0–20%
Electrical conductivity (0-40in)	0–2 mmhos/cm
Sodium adsorption ratio (0-40in)	0–13
Soil reaction (1:1 water) (0-40in)	6.3–8.2
Subsurface fragment volume <=3" (10-20in)	0–20%
Subsurface fragment volume >3" (10-20in)	0–15%

Ecological dynamics

The Loamy ecological site occurs across a relatively large landscape, slight variations within the plant community occur due to elevation, frost-free days, and relative effective annual precipitation. Bluebunch wheatgrass, for example, occupies most known combinations of elevation and climate within this Climate Subset. Warmer, drier sites tend to exhibit higher populations of warm-season shortgrasses such as blue grama and sand dropseed especially when soil surface textures trend toward sandy loams. Conversely, colder, wetter sites within this Land Resource Unit often exhibit slight increases in big sagebrush production, while bluebunch wheatgrass production also increases.

The Reference Plant Community is dominated by bluebunch wheatgrass (*Pseudoroegneria spicata*) and needle and thread (*Hesperostipa comata*). Subdominant species may include green needlegrass (*Nassella viridula*), a limited

extent of rough fescue (*Festuca campestris*), Wyoming big sage (*Artemisia tridentata* ssp. *wyomingensis*), winterfat (*Krascheninnikovia lanata*), and Indian ricegrass (*Achnatherum hymenoides*). This potential is suggested by investigations showing a predominance of perennial grasses on near-pristine range sites (Ross et al., 1973). In the reference plant community, shrubs are a relatively minor vegetative component.

Though not fully investigated or understood, rough fescue becomes a component of this ecological site in the northern portions of this MLRA, primarily near Deer Lodge, Helena, and White Sulphur Springs, where average precipitation amounts are near 11 to 12 inches. As part of the provisional ecological site description, rough fescue is included for this LRU; however, there may be justification for the need to create a new ecological site as typically rough fescue is found in higher precipitation zones. Its presence is likely a combination of three abiotic factors: 1) the depth of calcium carbonates, 2) heating and cooling days, and 3) latitude. Rough fescue may increase in proportion as calcium carbonate concentrations occur deeper in the soil profile. There is a basic correlation between an increase in rough fescue presence and an increase in heating degree days and cooling degree days. This suggests that as these areas take longer to heat up in the spring and summer, they will maintain a relatively lower temperature throughout the growing season. The heating/cooling days* may also be influenced by latitude effect on solar radiation in southwest Montana. In Montana, rough fescue exists primarily north of 45.5 degrees latitude, particularly in lower precipitation zones. These abiotic factors can be inferred from a slight increase in the availability of plant nutrients, water, and improved growing temperatures. Because the current Montana Ecological Site Key does not account for these three variables, more research is required to determine whether multiple ecological sites exist or not. A new physiographic Land Resource Unit may also be necessary.

*Heating degree days: number of days that the average day's temperature is below 65 °F (18 °C), requiring heating indoors to maintain 65 °F.

*Cooling degree days: number of days that the average day's temperature is above 65 °F (18 °C), requiring cooling indoors to maintain 65 °F.

A shift to the dominance of shrubs may occur in response to improper grazing management, drought, or where big sagebrush occurs due to a lack of fire. Shrub encroachment by a variety of species, including broom snakeweed (*Gutierrezia sarothrae*), fringed sagewort (*Artemisia frigida*), Wyoming big sagebrush (*Artemisia tridentata* ssp. *wyomingensis*), rubber rabbitbrush (*Ericameria nauseosa*), green rabbitbrush (*Chrysothamnus viscidiflorus*), and plains prickly pear (*Opuntia polyacantha*) occurs within this site as the mid-stature bunchgrasses decrease. Shrub dominance and grass loss are associated with soil erosion and, ultimately, thinning of the native soil surface. Subsequent loss of soil could lead to a Degraded State. All states could also lead to the Invaded State when there is a lack of weed prevention and control measures.

Historical records indicate that, prior to the introduction of livestock (cattle and sheep) during the late 1800s, elk and bison grazed this ecological site. Grazed areas received periodic high intensity, short duration grazing pressure due to bison's nomadic nature and herd structure. Livestock forage was noted as being minimal in areas recently grazed by bison (Lesica and Cooper 1997). Meriwether Lewis documented that he was met by 60 Shoshone warriors on horseback in August 1805, and the Corps of Discovery was later supplied with horses by the same band of Shoshone. This suggests that the areas near the modern-day Montana towns of Twin Bridges, Dillon, Grant, and Dell were grazed by an untold number of horses for nearly 50 years prior to the large introduction of cattle and sheep. The gold boom of the 1860s brought the first herds of livestock overland from Texas, and homesteaders began settling the area. During this time, cattle were the primary domestic grazers in the area. In the 1890s, sheep production increased by more than 400 percent and dominated the livestock industry until the 1930s. Since then, cattle production has dominated the region's livestock industry (Wyckoff and Hansen 2001).

Natural fire was a major ecological driver of this entire ecological site. Fire tended to restrict tree and sagebrush growth to small patches and promote an herbaceous plant community. The natural fire return interval was highly variable, ranging up to 100 years; however, it was likely shorter than 35 years (Arno and Gruell 1983). Since the great fires of 1910, there has been a significant increase in fire suppression, resulting in an increase in sagebrush and coniferous trees.

Due to the relatively neutral to slightly alkaline pH of the soils on this site, the potential for dryland farming is high. Hay and small grain production have constituted the largest replacement of native vegetation on this site, with introduced cool-season annual crops (wheat, barley, and oats), perennial introduced grass species, and legumes (e.g., alfalfa) being best adapted. This ecological site has also been converted to pastureland, usually with perennial grasses and legumes for grazing. Cropland, pastureland, and hayland are intensively managed with annual

cultivation, annual harvesting, and/or frequent use of herbicides, pesticides, and commercial fertilizers to increase production. Where irrigation water is available, this site is highly productive.

Dense clubmoss (*Selaginella densa*), in general, is a minor component of the reference plant community of the Loamy ecological site. The conditions that created large cover classes of clubmoss on this site point to a history of continuous (yearlong) or moderate spring grazing use (Sturm 1954). In some situations, the site could be old crop fields that have reverted back to rangeland. In this case, clubmoss is helping reduce erosion and increase site stability, especially where livestock use is restricted (such as in CRP). While dense clubmoss provides soil stability on sites where it exists, anecdotal evidence suggests that it competes for the limited water resources in the upper soil profile, which restricts plant-available water. However, a study from Canada (Colberg and Romo 2003) in a similar climate on similar soils indicates that the correlation between reduced plant-available water and clubmoss cover is negligible. Although quantitative evidence is lacking, the correlation between reduced plant production and competition for space may simply be due to reduced plant production. Dense patches of clubmoss also inhibit seed contact with the soil, reducing seedling recruitment. Due to the scarcity of data on the relationship between clubmoss and the loamy ecological site in MLRA 44B, more research is required before considering creating its own state in the state and transition modeling so that this community is included in the invading state.

Some of the major invasive species that can occur on this site include (but are not limited to) spotted knapweed (*Centaurea stoebe*), leafy spurge (*Euphorbia esula*), sulphur cinquefoil (*Potentilla recta*), cheatgrass (*Bromus tectorum*), field brome (*Bromus arevensis*), yellow toadflax (*Linaria vulgaris*), and dandelion (*Taraxicum* spp.). Invasive weeds are beginning to have a high impact on this ecological site due to primarily human impacts from mismanaged grazing and urban development.

Plant Communities and Transitions

A state and transition model (STM) for the Loamy ecological site is depicted below. Thorough descriptions of each state, transition, plant community, and pathway follow the model. This model is based on available experimental research, field data, field observations, and interpretations by experts. It is likely to change as knowledge increases.

The plant communities within the same ecological site will differ across the MLRA due to the naturally occurring variability in weather, soils, and aspect. The biological processes on this site are complex; therefore, representative values are presented in a land management context. The species lists are representative and are not botanical descriptions of all species occurring, or potentially occurring, on this site. They are intended to cover the core species and the known range of conditions and responses.

Both percent species composition by weight and percent canopy cover are referenced in this document. Canopy cover drives the transitions between communities and states because of the influence of shade, the interception of rainfall, and the competition for available water. Species composition by dry weight remains an important descriptor of the herbaceous community and of the community as a whole. Woody species are included in the species composition for the site. Calculating the similarity index requires species composition by dry weight.

Although there is considerable qualitative experience supporting the pathways and transitions within the state and transition model (STM), no quantitative information exists that specifically identifies threshold parameters between grassland types and invaded types in this ecological site. For information on STMs, see the following citations: Bestelmeyer et al. (2003), Bestelmeyer et al. (2004), Bestelmeyer and Brown (2005), and Stringham et al. (2003).

State and transition model

Land uses

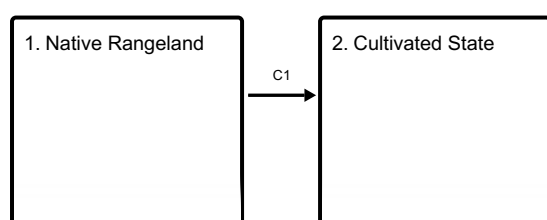

Land use 1 submodel, ecosystem states

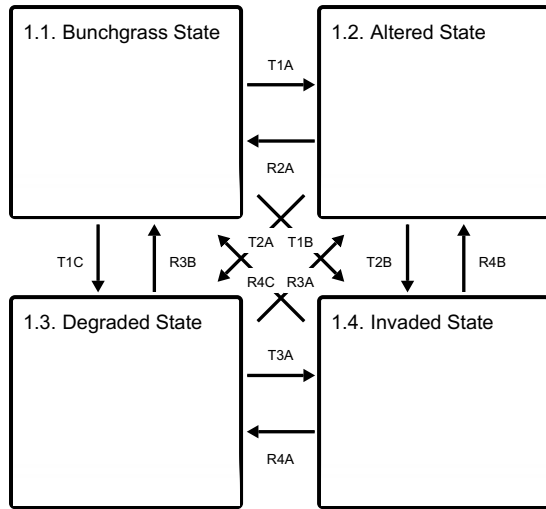

State 1 submodel, plant communities

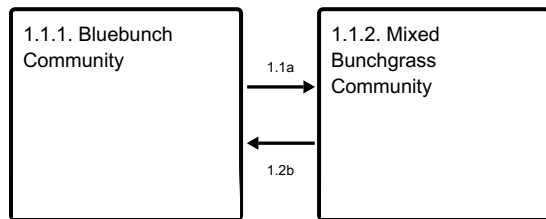

State 2 submodel, plant communities

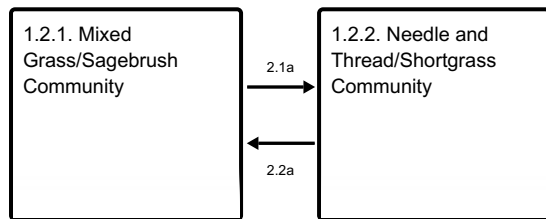

State 3 submodel, plant communities

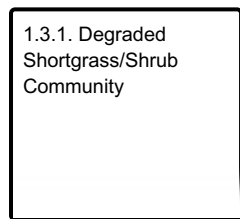

State 4 submodel, plant communities

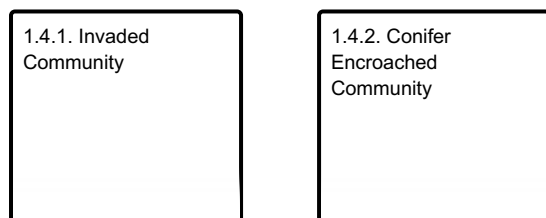

Land use 2 submodel, ecosystem states

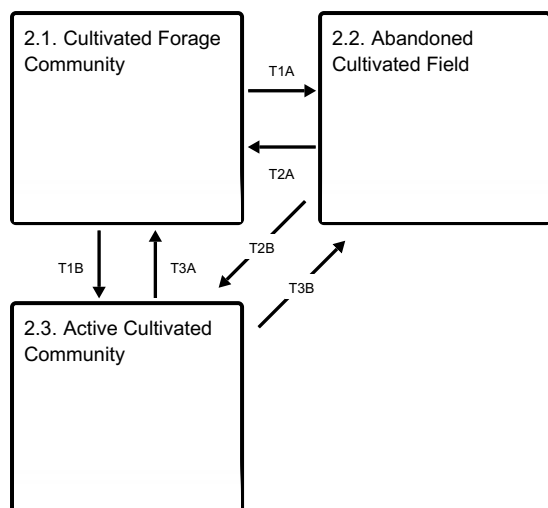

Land use 1 Native Rangeland

Site is native rangeland that has not been modified by mechanical manipulations.

State 1.1 Bunchgrass State

The Bunchgrass State is considered the Reference State of this ecological site. The state consists of two known potential plant communities, the Bluebunch Community and the Mixed Bluebunch Community. These are described below but are generally characterized by a mid-statured, cool-season grass community with limited shrub production. Community 1.1 is dominated by bluebunch wheatgrass and is considered the reference, while Community 1.2 has a codominance of bluebunch and needle and thread with an increase in green rabbitbrush and Wyoming big sagebrush. These communities may meld into each other due to the varying conditions that occur in Southwest Montana, particularly during dry cycles where the needle and thread growth cycle takes better advantage of the limited moisture.

Community 1.1.1 Bluebunch Community

In this Reference Plant Community, bluebunch wheatgrass (*Pseudoroegneria spicata*), green needlegrass (*Nassella viridula*), and needle and thread (*Hesperostipa comata*) are typically dominant. Basin wildrye and rough fescue may also be present. Shrub species (big sagebrush, fringed sagewort, and broom snakeweed) remain a minor part of the community. In areas where the soil texture is coarser, spineless horsebrush (*Tetradymia canescens*) may occupy a small niche. Sandberg bluegrass (*Poa secunda*) and dryland sedges are also common. This state occurs on this Loamy site in areas with proper livestock grazing or in areas with little or no grazing pressure. Bluebunch wheatgrass lacks resistance to grazing during the critical growing season (spring) and will decline in vigor and production if grazed in the critical growing season more than one year in three (Wilson et al. 1960). The Bunchgrass State is moderately resilient and will return to dynamic equilibrium following a relatively short period of stress (such as drought or short-term improper grazing), provided a return of favorable or normal growing conditions and properly managed grazing. As discussed in the Ecological Dynamics section, the natural fire regime restricted shrubs to relatively small portions of Reference Plant Community 1.1. Shrub species present may include basin big sagebrush (*Artemisia tridentata* ssp. *tridentata*), Wyoming big sagebrush, winterfat, tarragon (*Artemisia drucunculus*), and fringed sagewort. Infrequent fire probably maintained big sagebrush communities as open, seral stands of productive herbaceous species with patches of big sagebrush.

Resilience management. Prescribed Grazing, Prescribed Burning, Brush Management, Pest Management

Dominant plant species

- big sagebrush (*Artemisia tridentata*), shrub
- winterfat (*Krascheninnikovia lanata*), shrub

- spineless horsebrush (*Tetradymia canescens*), shrub
- bluebunch wheatgrass (*Pseudoroegneria spicata*), grass
- needle and thread (*Hesperostipa comata*), grass
- green needlegrass (*Nassella viridula*), grass
- Sandberg bluegrass (*Poa secunda*), grass

Table 6. Annual production by plant type

Plant Type	Low (Lb/Acre)	Representative Value (Lb/Acre)	High (Lb/Acre)
Grass/Grasslike	1126	1318	1658
Shrub/Vine	133	155	195
Forb	66	78	98
Total	1325	1551	1951

Table 7. Soil surface cover

Tree basal cover	0%
Shrub/vine/liana basal cover	0%
Grass/grasslike basal cover	0%
Forb basal cover	0%
Non-vascular plants	0%
Biological crusts	0-10%
Litter	35-65%
Surface fragments >0.25" and <=3"	0-20%
Surface fragments >3"	0-5%
Bedrock	0%
Water	0%
Bare ground	10-17%

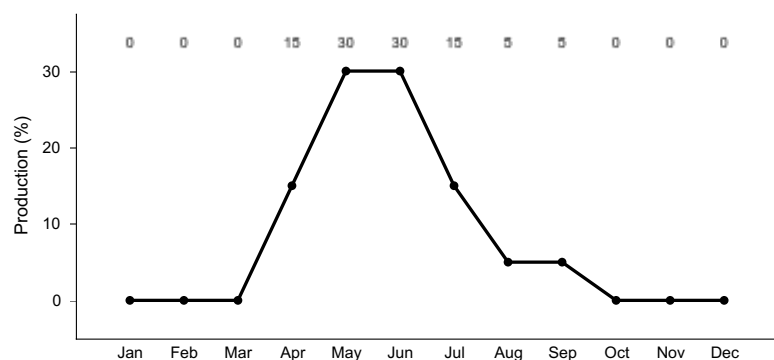

Figure 8. Plant community growth curve (percent production by month). MT44B032, Dry Uplands. Cool season grass dominated system. Most dry, upland sites located within MLRA 44B LRU A are characterized by early season growth which is mostly complete by Mid-July. Limited fall "green-up" if conditions allow..

Community 1.1.2 Mixed Bunchgrass Community

Needle and thread, western wheatgrass (*Pascopyrum smithii*), and thickspike wheatgrass (*Elymus lanceolatus*) tolerate grazing pressure better than bluebunch wheatgrass, rough fescue, and green needlegrass. The growing point of these grasses is several inches above the ground, making them very susceptible to close grazing (Smoliack et al., 2006), while needle and thread and rhizomatous wheatgrass growing points tend to be near the plant base.

When more palatable and less grazing-tolerant plants decline due to poor grazing management, the species composition of rhizomatous wheatgrasses and needle and thread increases. The grazing tolerant grasses and bluebunch wheatgrass share dominance in the Mixed Bunchgrass Community (1.2). Other grass species, which are more tolerant to grazing and are likely to increase in number compared to the Reference Plant Community, include Sandberg bluegrass (*Poa secunda*), prairie Junegrass, and blue grama (*Bouteloua gracilis*). Increaser forbs include western yarrow, Hood's phlox (*Phlox hoodii*), scarlet globemallow (*Sphaeralcea coccinea*), hairy goldenaster (*Heterotheca villosa*), and pussytoes (*Antennaria* spp.). Fringed sagewort (*Artemisia frigida*) is a shrub that also increases under prolonged drought or heavy grazing and can respond to precipitation that falls in July and August. Heavy, continuous grazing will reduce plant cover and litter. The timing of grazing is important on this site because of the moisture limitations beyond June, especially on the drier sites. Bare ground will increase, exposing the soil to erosion. Litter and mulch will be reduced as plant cover declines. As long as bluebunch wheatgrass is still a dominant species in total biomass production, the site can be returned to the Bluebunch Wheatgrass Community (Pathway 1.2A) under proper grazing management and favorable growing conditions. Needle and thread and western wheatgrass will continue to increase until they make up the majority of the species composition. Once bluebunch wheatgrass has been reduced to less than 20 percent of the community, it may be difficult for the site to recover to the Reference Plant Community (1.1). The risk of soil erosion increases when canopy cover decreases. As soil conditions degrade, there will be a loss of organic matter, reduced litter, and reduced soil fertility. Degraded soil conditions increase the difficulty of reestablishing bluebunch wheatgrass and returning to the Reference Community (1.1). The Mixed Bunchgrass Community (1.2) is the at-risk plant community for this ecological site. When overgrazing continues, increaser species such as needle-and-thread and native forb species will become more dominant, and this triggers the change to the Altered State (2) or the Degraded State (3). Until the Mixed Bunchgrass Community (1.2) crosses the threshold into the Needle and Thread Community (2.1) or the Invaded Community (4.1), this community can be managed toward the Bluebunch Wheatgrass Community (1.1) using prescribed grazing and strategic weed control. It may take several years to achieve this recovery, depending on growing conditions, the vigor of remnant bluebunch wheatgrass plants, and the aggressiveness of the weed treatments.

Resilience management. prescribed grazing, brush management, pest management, prescribed fire

Dominant plant species

- big sagebrush (*Artemisia tridentata*), shrub
- winterfat (*Krascheninnikovia lanata*), shrub
- rubber rabbitbrush (*Ericameria nauseosa*), shrub
- yellow rabbitbrush (*Chrysothamnus viscidiflorus*), shrub
- needle and thread (*Hesperostipa comata*), grass
- bluebunch wheatgrass (*Pseudoroegneria spicata*), grass

Pathway 1.1a

Community 1.1.1 to 1.1.2

Bluebunch wheatgrass loses vigor with improper grazing or extended drought. When vigor declines enough for plants to die or become smaller, species with higher grazing tolerance (in this ecological site, that would be needle and thread) increase in vigor and production as they access the resources previously used by bluebunch wheatgrass. The reduction in bluebunch wheatgrass species composition by weight to less than 50 percent indicates that the plant community has shifted to the Mixed Bunchgrass Community (1.2). The driver for community shift 1.1A is improper grazing management or prolonged drought. This shift is triggered by the loss of vigor of bluebunch wheatgrass, soil erosion, or prolonged drought coupled with improper grazing. Blaisdell (1958) stated that drought and warmer-than-normal temperatures are known to advance plant phenology by as much as one month. During drought years, plants may be especially sensitive or reach a critical stage of development earlier than expected. Since needle and thread normally seeds out in June and bluebunch wheatgrass in July, this should be taken into consideration when planning grazing management.

Pathway 1.2b

Community 1.1.2 to 1.1.1

The Mixed Bunchgrass Community (1.2) will return to the Bluebunch Wheatgrass Community (1.1) with proper grazing management and appropriate grazing intensity. Favorable moisture conditions will facilitate or accelerate

this transition. It may take several years of favorable conditions for the community to transition back to a bluebunch dominated state. The driver for this community shift (1.2A) is the increased vigor of bluebunch wheatgrass, to the point that it represents more than 50 percent of species composition. The trigger for this shift is the change in grazing management favoring bluebunch wheatgrass. These triggers are generally conservative grazing management styles such as deferred or rest rotations utilizing moderate grazing (less than 50 percent use) combined with favorable growing conditions such as cool, wet springs. These systems tend to promote increases in soil organic matter, which promotes microfauna and can increase infiltration rates. Inversely, long periods of rest at a time when this state is considered stable may not result in an increase in bluebunch wheatgrass, and it has been suggested (Noy-Meir 1975) that these long periods of rest or underutilization may actually drive the system to a lower level of stability by creating large amounts of standing biomass, dead plant caudex centers, and gaps in the plant canopy.

Conservation practices

Prescribed Burning
Prescribed Grazing

State 1.2 Altered State

This state is characterized by having less than 15 percent bluebunch wheatgrass by dry weight. It is represented by two (2) communities that differ in the percent composition of needle and thread, production, and soil degradation. Production in this state can be similar to that in the Bunchgrass State (1). Some native plants tend to increase under prolonged drought and heavy grazing practices. A few of these species may include needle and thread, Sandberg bluegrass, scarlet globemallow, hairy goldenaster, and fringed sagewort.

Characteristics and indicators. Less than 15% bluebunch wheatgrass Increase in short stature grasses Increase in bare ground (near 35%)

Resilience management. Conservative grazing management, Integrated Pest Management, time

Dominant plant species

- big sagebrush (*Artemisia tridentata*), shrub
- yellow rabbitbrush (*Chrysothamnus viscidiflorus*), shrub
- broom snakeweed (*Gutierrezia sarothrae*), shrub
- rubber rabbitbrush (*Ericameria nauseosa*), shrub
- needle and thread (*Hesperostipa comata*), grass
- Sandberg bluegrass (*Poa secunda*), grass
- prairie Junegrass (*Koeleria macrantha*), grass
- bluebunch wheatgrass (*Pseudoroegneria spicata*), grass

Community 1.2.1 Mixed Grass/Sagebrush Community

Long-term grazing mismanagement with continuous growing-season pressure will reduce the total productivity of the site and lead to an increase in bare ground. Suppression of fire can also promote shrub growth, increasing plant interspaces. Once plant cover is reduced, the site is more susceptible to erosion and degradation of soil properties. Soil erosion or reduced soil fertility will result in reduced plant production. This soil erosion or loss of soil fertility indicates the transition to the Altered State (2) because it creates a threshold requiring energy input to return to the Bunchgrass State (1). Transition to the Mixed Grass/Sagebrush Community (2.1) may be exacerbated by extended drought conditions. Needle and thread dominates the Mixed Grass/Sagebrush Community (2.1). Bluebunch wheatgrass makes up less than 15 percent of the species composition by dry weight, and the remaining bluebunch wheatgrass plants tend to be scattered and low in vigor. Invasive species will become more common. Hairy goldenaster, Missouri goldenrod, stonecrop, and yarrow are examples of increaser forbs. It is not uncommon for a minor component of invader species such as dandelion and yellow salsify (*Tragapogon dubius*) to be present. This creates more competition for bluebunch wheatgrass and makes it difficult for bluebunch wheatgrass to quickly respond to a change in grazing management alone. Therefore, an input of energy is required for the community to

return to the Bunchgrass State (1). Wind and water erosion may be eroding soil from the plant interspaces. Soil fertility is reduced, and soil surface erosion resistance has declined compared to the Bunchgrass State (1). Wyoming big sagebrush steppe communities historically had low fuel loadings and were characterized by 10- to 70-year interval fires that produced a mosaic of burned and unburned lands (Bunting et al., 1987). Following the fire on the fine-textured soils, the perennial bunchgrasses recovered in a few years and were present to fuel a subsequent fire. Conversely, extensive wildfires burning under hot, dry conditions would have resulted in the nearly complete destruction of scattered sagebrush (Arno and Gruell 1983). Winterfat is tolerant of low-intensity fire but will kill with a hot fire (Pellant 1984). This community crossed a threshold compared to the Mixed Bunchgrass Community (1.2) due to the erosion of soil, vegetation composition, loss of soil fertility, or degradation of soil conditions. This results in a critical shift in the ecology of the site. The effects of soil erosion can alter the hydrology, soil chemistry, soil microorganisms, and soil structure to the point where intensive restoration is required to restore the site to another state or community. Changing grazing management alone cannot create sufficient improvement to restore the site within a reasonable time frame. Dormaar (1997) stated that with decreased grazing pressure, a needle and thread/blue grama plant community did not change species composition, but the content of the soil carbon increased. It will require a considerable input of energy to move the site back to Bunchgrass State (1). This state has lost soil or vegetation attributes to the point that recovery to the Bunchgrass State (1) will require reclamation efforts, i.e., soil rebuilding, intensive mechanical treatments, and/or reseeding. The transition to this state could result from overgrazing and fire suppression, especially repeated early-season grazing coupled with extensive drought. If heavy grazing continues, plant cover, litter, and mulch will continue to decrease, and bare ground will increase, exposing the soil to accelerated erosion. Litter and mulch will move off-site as plant cover declines. The Mixed Grass/Sagebrush Community will then shift to a Shortgrass/Shrub Community (2.2). Continued improper grazing will drive the community to a Degraded Shrub/Shortgrass State (3). Introduction or expansion of invasive species will further drive the plant community into the Invaded State (4).

Dominant plant species

- big sagebrush (*Artemisia tridentata*), shrub
- yellow rabbitbrush (*Chrysothamnus viscidiflorus*), shrub
- rubber rabbitbrush (*Ericameria nauseosa*), shrub
- broom snakeweed (*Gutierrezia sarothrae*), shrub
- needle and thread (*Hesperostipa comata*), grass
- Sandberg bluegrass (*Poa secunda*), grass
- bluebunch wheatgrass (*Pseudoroegneria spicata*), grass
- prairie Junegrass (*Koeleria macrantha*), grass

Community 1.2.2

Needle and Thread/Shortgrass Community

With continued mismanagement of grazing, especially coupled with prolonged drought, needle and thread will decrease in vigor. The bunchgrasses will decline in production as plants die or become smaller, and species with higher grazing tolerance (such as western wheatgrass) will increase in vigor and production as they respond to resources previously used by the bunchgrasses. These less desirable, shallow-rooted species will become co-dominant with the bunchgrasses. Shrubs will become more competitive for limited moisture as bare ground and soil erosion increase. This state may exhibit conditions where livestock are consuming shrubs.

Dominant plant species

- broom snakeweed (*Gutierrezia sarothrae*), shrub
- yellow rabbitbrush (*Chrysothamnus viscidiflorus*), shrub
- rubber rabbitbrush (*Ericameria nauseosa*), shrub
- big sagebrush (*Artemisia tridentata*), shrub
- needle and thread (*Hesperostipa comata*), grass
- Sandberg bluegrass (*Poa secunda*), grass
- prairie Junegrass (*Koeleria macrantha*), grass
- bluebunch wheatgrass (*Pseudoroegneria spicata*), grass

Pathway 2.1a

Community 1.2.1 to 1.2.2

The driver for community shift 2.1A is continued improper grazing management. This shift is triggered by continued loss of bunchgrass vigor, especially Needle-and-thread. The short-statured grasses will become more competitive and become co-dominant with the bunchgrasses. Shrubs will increase in canopy cover however may be browsed resulting in spreading formations.

Pathway 2.2a

Community 1.2.2 to 1.2.1

If proper grazing management is implemented needle-and-thread may regain its vigor and move towards the needle-and-thread community (2.1). This will give grasses an advantage over invading shrubs before too much competition takes place. The advantage to grasses comes from following a conservative grazing plan where utilization is reduced and rest or deferment is incorporated since the transition from Plant community 2.1 to Plant community 2.2 is likely caused by repeated heavy utilization. Van Poolen and Lacey (1979) found that forage production increased by an average of 35% on western ranges when converting heavy to moderate utilization (less than 50%). Shrub removal and favorable growing conditions can accelerate this process. If the site contains Wyoming big sagebrush (*Artemisia tridentata* spp. *Wyomingensis*), low intensity fire or mechanical treatment (Wambolt 1986) could reduce shrub competition and allow for increased vigor and the reestablishment of grass species.

Conservation practices

Brush Management
Prescribed Burning
Prescribed Grazing

State 1.3

Degraded State

Degraded State lacks midstatured bunchgrasses. Sandberg bluegrass and prairie Junegrass dominant grasses, increase shrubs nearly replace larger shrub species. Larger shrub species that remain are heavily hedged. This state is likely a terminal one (e.g., restoration will likely be impossible, unsuccessful, or require major energy inputs).

Characteristics and indicators. 25-50% bare ground annual grasses common complete removal of bluebunch wheatgrass and replaced with sandberg bluegrass, western wheatgrass, and blue grama sagebrush nearly gone and replaced with rabbitbrush and broom snakeweed

Resilience management. Prescribed grazing, Range seeding, Brush Management, Integrated Pest Management

Dominant plant species

- broom snakeweed (*Gutierrezia sarothrae*), shrub
- yellow rabbitbrush (*Chrysothamnus viscidiflorus*), shrub
- rubber rabbitbrush (*Ericameria nauseosa*), shrub
- plains pricklypear (*Opuntia polyacantha*), shrub
- Sandberg bluegrass (*Poa secunda*), grass
- blue grama (*Bouteloua gracilis*), grass
- prairie Junegrass (*Koeleria macrantha*), grass
- sixweeks fescue (*Vulpia octoflora*), grass
- needle and thread (*Hesperostipa comata*), grass

Community 1.3.1

Degraded Shortgrass/Shrub Community

Soil loss continues or increases to the point that native perennial grasses make up less than 350 pounds of annual dry weight production. Grass and forb cover may be very sparse or clumped (canopy cover <30%). Weeds, annual species or shrubs dominate the plant community. Mid-stature perennial bunchgrass species (e.g., needle-and-thread) may exist, but only in small patches. This could occur due to overgrazing (failure to adjust stocking rate to

declining forage production due to increased invasive dominance), long-term lack of fire (if Wyoming Big Sagebrush occurs), or introduction of invasive species. Production values may be as low as 200 lbs per acre with up to 70-90% basal bare ground (foliar canopy is disregarded as a measurement) and plant basal area shrinks. In the most severe stages of degradation, there is a significant amount of bare ground, and large gaps occur between plants. Potential exists for soils to erode to the point that irreversible damage may occur. This is a critical shift in the ecology of the site. Soil erosion combined with lack of organic matter deposition due to sparse vegetation create changes to the hydrology, soil chemistry, soil microorganisms, and soil structure to the point where intensive restoration is required to restore the site to another state or community. Changing management (i.e., improving grazing management) cannot create sufficient change to restore the site within a reasonable time frame. This state is characterized by soil surface degradation and little plant soil surface cover. The forb component changes to be dominated by spiny phlox (*Phlox hoodii*) and shrub canopy cover is usually greater than 20%. Big sagebrush is replaced with a dominant community of broom snakeweed, rubber rabbitbrush, fringed sagewort, and plains pricklypear cactus. This state has lost soil or vegetation attributes to the point that recovery to the Bunchgrass Grassland State will require reclamation efforts, i.e. soil rebuilding, intensive mechanical treatments, and/or reseeding. This plant community may be in a terminal state that will not return to the reference state because of degraded soil conditions and loss of higher successional native plant species. Key factors of approach to transition: Decrease in grass canopy cover and production, increase of shrub canopy cover, increases in mean bare patch size, increases in soil crusting, decreases in cover of cryptobiotic crusts, decreases in soil aggregate stability, and/or evidence of erosion including water flow patterns and litter movement.

State 1.4 Invaded State

The Invaded State is identified as being in the exponential growth phase of invader abundance where control is a priority. Dominance (or relative dominance) of noxious or invasive species reduces species diversity, forage production, wildlife habitat, and site protection. A level of 20 percent invasive species composition by dry weight indicates that a substantial energy input will be required to create a shift to the grassland state (herbicide, mechanical treatment), even with a return to proper grazing management or favorable growing conditions. Prescriptive grazing can be used to manage invasive species. In some instances, carefully targeted grazing (sometimes in combination with other treatments) can reduce or maintain the species composition of invasive species.

Characteristics and indicators. High amounts of invading species (both native and introduced).

Resilience management. Integrated Pest Management Prescribed Grazing Brush Management Prescribed Fire Range Seeding

Community 1.4.1 Invaded Community

Communities in this state may be structurally indistinguishable from the bunchgrass state except that invasive/noxious species exceed 20% of species composition by dry weight. This state may also include a community similar to the Degraded Shortgrass State (3) except that invasive/noxious species exceed 20% of species composition by dry weight. Although there is no research to document the level of 20%, this is estimated to be the point in the invasion process following the lag phase based on interpretation of Masters and Sheley 2001. For aggressive invasive species (i.e., spotted knapweed) a 20% threshold could be less than 10 percent. Early in the invasion process there is a lag phase where the invasive plant populations remain small and localized for long periods before expanding exponentially (Hobbs and Humphries 1995). Production in the invaded community may vary greatly. A site dominated by Kentucky bluegrass or spotted knapweed, where soil fertility and chemistry remain near reference, may have production near that of the reference community. A site with degraded soils and an infestation of cheatgrass may produce only 10 to 20 percent of the reference community. Dense clubmoss has been included in this community until more information has been collected on its relationship with the Loamy Ecological Site. Since dense clubmoss is a portion of the reference plant community, it will only be considered as part of the invaded community when it significantly impacts plant production. The exact percent cover clubmoss at which it affects overall production has not been fully studied in this MLRA. Once invasive species dominate the site, either in species composition by weight or in their impact on the community the threshold has been crossed to the Invaded State (4). As invasive species such as spotted knapweed, cheatgrass, and leafy spurge become established, they become very difficult to eradicate. Therefore considerable effort should be placed in preventing plant communities

from crossing a threshold to the Invaded State (4) through early detection and proper management. Preventing new invasions is by far the most cost-effective control strategy, and typically places an emphasis on education. Control measures used on the noxious plant species impacting this ecological site include chemical, biological, and cultural control methods. The best success has been found with an integrated pest management (IPM) strategy that incorporates one or several of these options along with education and prevention efforts (DiTomaso 2000).

Community 1.4.2

Conifer Encroached Community

Rocky Mountain juniper (*Juniperus scopulorum*), Douglas fir (*Pseudotsuga menziesii*), and/or Ponderosa pine (*Pinus ponderosa*) encroachment is limited on this ecological site and is generally focused in areas where the mountains of MLRA 44B transition quickly to MLRA 43B. Under the Reference State, no conifers should exist on this site. Conifer encroachment likely occurs in the late stages of the Altered State (see State-and-transition model) where there is an increase of bare ground due to a combination of factors. Fire suppression and improper grazing management are the two most common triggers. The exact conditions in which juniper begins to encroach vary however the trend points to a combination of 1 or more of the following: moderately heavy to heavy grazing, reduced (non-existent) fire frequency, increased atmospheric carbon, and generally warmer climate (compared to that of pre-settlement). When heavy grazing occurs areas in the plant canopy open allowing for seed dispersal by bird or overland flow via rills on neighboring sites. The effects of juniper encroachment are not immediately noticed however over time as juniper canopy increases; light and water interception increase which reduce opportunities for herbaceous plants. One paper (Barrett, 2007) suggests that for precipitation to penetrate the juniper canopy, events must be greater than 0.30 inches. Increase juniper canopy creates perching sites for predators which reduces site suitability for greater sage grouse. More information is needed on the full extent and impact of conifer encroachment on this plant communities for an approved Ecological Site Description. Studies (Miller et al 2000) based in a similar community to the Rocky Mountain Juniper community of Montana suggest following a phased approach to characterize the juniper stand. Not unlike the Western Juniper community discussed in Miller et al, the Rocky Mountain juniper communities of Montana exhibit 3 or 4 different phases based, at this time, on unquantified information. Phase I (Early) is defined by actively expanding juniper cover with generally <10% canopy cover and the trees' limbs generally touch the ground. This early stage generally has not lost its hydrologic functions however herbaceous plant communities may show signs of reduced production and species richness. Control methods include mechanical removal and prescribed fire. Prescribed fire is still effective in this phase as it still contains the necessary native plants for recovery. The tree canopy is also low enough that risk of a dangerously hot fire is reduced. Phase II (Mid Stage) is still actively expanding however canopy cover may reach up to 25% and due to the more mature trees seed production is very high. This Mid Phase begins to highly restrict herbaceous and shrubby plant and junipers tend to be codominant. Hydrology is departing from reference with rills becoming longer and in isolated areas erosional gullies may exist. Control methods of the Mid Stage should focus on mechanical treatment as there is a high risk of catastrophic and potentially sterilizing fire. Phase III (Late stage) is where juniper cover exceed 25% and has slowed as a forest condition. Lower limbs of trees begin to die and the shrub cover is nearly lost. Traveling through this community is increasingly difficult. Junipers become the dominant plant with herbaceous plant production greatly decreased. Bare ground increases and hydrologic function is nearly lost compared to a grass/shrub community. Late Stage Phase should focus more on restoration than control as the necessary plants will likely not be present to cross the threshold back to a rangeland situation. The soil stability and hydrologic function are lacking in this phase so mechanical removal of juniper will be necessary. Phase IV (Closed) is the steady state forest where the system is nearly absent of rangeland plants. The trees stop producing seed and begin to close in on each other. This phase is impassible and nearly all light and precipitation are intercepted. Bare ground is high and soil chemistry slowly changes due to acidification from juniper. Within this LRU, the closed phase is extremely rare due to 2 reasons: 1) this phase takes upwards of 100 years to occur 2) management often occurs before trees are allowed to reach this phase. The presence of sagebrush stumps indicates the historical plant community as rangeland which will prevent misclassification of historic Juniper Forests (often >100 years of age).

Transition T1A

State 1.1 to 1.2

The Bunchgrass State (1) transitions to the Altered Bunchgrass State (2) if bluebunch wheatgrass, by dry weight, decreases to below 10% or if bare ground cover is increased beyond 20%. The driver for this transition is loss of taller bunchgrasses, which creates open areas in the plant canopy with bare soil. Soil erosion results in decreased soil fertility, driving transitions to the Altered Bunchgrass State. There are several other key factors signaling the

approach of transition T1A: increases in soil physical crusting, decreases in cover of cryptogamic crusts, decreases in soil surface aggregate stability and/or evidence of erosion including water flow patterns, development of plant pedestals, and litter movement. The trigger for this transition is improper grazing management and/or long-term drought leading to a decrease in bluebunch wheatgrass composition to <15% and reduction in total plant canopy cover.

Conservation practices

Brush Management
Prescribed Burning
Prescribed Grazing

Transition T1C State 1.1 to 1.3

The Bunchgrass State (1) transitions to the Degraded Shrub/Shortgrass State (3) when Bluebunch wheatgrass is removed from the plant community and Needle-and-thread is subdominant to short statured bunchgrasses such as Sandberg bluegrass. The trigger for this transition is loss of taller bunchgrasses, which creates open spaces with bare soil. Soil erosion results in decreased soil fertility, driving transitions to the Degraded Shrub/Shortgrass State. There are several other key factors signaling the approach of transition T1C: increases in soil physical crusting, decreases in cover of cryptogamic crusts, decreases in soil surface aggregate stability and/or evidence of erosion including water flow patterns, development of plant pedestals, and litter movement. The driver for this transition is improper grazing management, intense or repeated fires, and/or heavy human disturbance. Rapid transition is generally realized where livestock are confined to small pastures for long periods of time.

Transition T1B State 1.1 to 1.4

Healthy plant communities are most resistant to invasion however, regardless of grazing management, without some form of active weed management (chemical, mechanical, or biological control) and without prevention the Bunchgrass State (1) can transition to the Invaded State (4) in the presence of aggressive invasive species such as spotted knapweed, leafy spurge, and cheatgrass. The Central Rocky Mountain Valleys tend to resist invasion of cheatgrass however repeated heavy grazing or intense human activities can open the interspaces of the bunchgrass community and allow for encroachment. Long-term stress conditions for native species (e.g., overgrazing, drought, and fire) accelerate this transition. If populations of invasive species reach critical levels, the site transitions to the Invaded State. The trigger for this transition is the presence of aggressive invasive species. Species composition by dry weight of invasive species approaches 10%.

Restoration pathway R2A State 1.2 to 1.1

The Altered Bunchgrass State (2) has lost soil or vegetation attributes to the point that recovery to the Bunchgrass State (1) will require reclamation efforts such as soil rebuilding, intensive mechanical and cultural treatments, and/or revegetation. Examples of mechanical treatment may be brush control while cultural treatments may include prescribed grazing, targeted brush browsing, or prescribed burning. Low intensity prescribed fires to reduce competitive increaser plants such as needle-and-thread and Sandberg bluegrass. A low intensity fire will also reduce Wyoming big sagebrush densities. In areas with potential of annual grass infestation, fire should be carefully planned or avoided. The drivers for this restoration pathway are reclamation efforts along with proper grazing management.

Conservation practices

Brush Management
Prescribed Burning
Fence
Livestock Pipeline

Grazing Land Mechanical Treatment
Range Planting
Prescribed Grazing

Transition T2A

State 1.2 to 1.3

As improper grazing management continues vigor of bunch grasses will decrease, and the shorter grasses and shrubs will increase towards the Degraded Shortgrass State (3). Prolonged drought will provide a competitive advantage to shrubs allowing them to become co-dominant with grasses. Shrub canopy will increase. Key transition factors: increase of native shrub canopy cover; reduction in bunchgrass production; decrease in total plant canopy cover and production; increases in mean bare patch size; increases in soil crusting; decreases in cover of cryptobiotic crusts; decreases in soil aggregate stability; and/or evidence of erosion including water flow patterns and litter movement.

Transition T2B

State 1.2 to 1.4

Invasive species can occupy the Altered State (2) and drive it to the Invaded State (4). The Altered State is at risk if invasive seeds and/or other viable material are present. The driver for this transition is more than 20% dry weight of invasive species. The trigger is the presence of seeds and/or other viable material of invasive species.

Restoration pathway R3B

State 1.3 to 1.1

The Degraded Shortgrass State (3) has lost soil or vegetation attributes to the point that recovery to the Bunchgrass State (1) will require reclamation efforts, such as soil rebuilding, intensive mechanical treatments, and/or revegetation. Studies suggest (Whitford et al 1989) a mulch with high carbon to nitrogen ratio such as wood chips or bark in low moisture scenarios can be beneficial for slow mobilization of plant available nitrogen. Biochar may also be added to the system to improve Soil Organic Carbon (SOC) which should improve Cation Exchange Capacity (CEC), microbial activity, and hydrologic conductivity (Stavi 2012). The drivers for the restoration pathway are removal of increaser species, restoration of native bunchgrass species, persistent management of invasives and shrubs, and proper grazing management. Without continued control, invasive and shrub species are likely to return (probably rapidly) due to presence of seeds and/or other viable material in the soil and management related increases soil disturbance.

Conservation practices

Brush Management
Prescribed Burning
Fence
Grazing Land Mechanical Treatment
Range Planting
Prescribed Grazing

Restoration pathway R3A

State 1.3 to 1.2

Since the bunchgrass plant community has been significantly reduced, restoration to the Altered State (2) is unlikely unless a seed source is available. If a sufficient amount of grass remains on the site, chemical application and/or biological control in conjunction with proper grazing management, can reduce the amount of shrubs and invasive species and restore the site to the Shortgrass Community (2.2). Low intensity fire can be utilized to reduce Wyoming big sagebrush competition and allow the reestablishment of grass species. Caution must be used when considering fire as a management tool on sites with fire tolerant shrubs such as rubber rabbitbrush, as these shrubs

will re-sprout after a burn. Broom snakeweed and fringed sagewort may or may not re-sprout depending on conditions (USDA Forest Service 2011).

Conservation practices

Brush Management
Prescribed Burning
Range Planting
Integrated Pest Management (IPM)
Prescribed Grazing

Transition T3A State 1.3 to 1.4

Invasive species can occupy the Degraded Shortgrass State (3) and drive it to the Invaded State (4). The Degraded Shortgrass State is at risk of this transition occurring if invasive seeds or viable material are present. The driver for this transition is presence of critical population levels of invasive species. The trigger is the presence of seeds or viable material of invasive species. This state has sufficient bare ground that the transition could occur simply due to presence or introduction of invasive seeds or viable material. This is particularly true of aggressive invasive species such as spotted knapweed and cheatgrass. This transition could be assisted by overgrazing (failure to adjust stocking rate to declining forage production), long-term lack of fire, or extensive drought.

Restoration pathway R4C State 1.4 to 1.1

Restoration of the Invaded State (4) to the Bunchgrass State (1) requires substantial energy input. The drivers for the restoration pathway are the removal of invasive species, restoration of native bunchgrass species, persistent management of invasive species, and proper grazing management. Without continued control, invasive species are likely to return (probably rapidly) due to the presence of seeds and/or other viable material in the soil and management-related practices that increase soil disturbance. If invaded by conifer encroachment, treatment depends on the condition of the rangeland. See Plant community 4.1 for alternative measures of restoration. Sites that have transitioned from the Degraded State (3) to the Invaded State (4) may be severely lacking in soil and vegetative properties that will allow for restoration to the Reference State. Hydrologic function damage may be irreversible, especially with accelerated gully erosion.

Conservation practices

Brush Management
Prescribed Burning
Range Planting
Integrated Pest Management (IPM)
Rangeland Fertilization
Prescribed Grazing

Restoration pathway R4B State 1.4 to 1.2

If invasive species are removed before remnant populations of bunchgrasses have been drastically reduced the Invaded State (4) can return to the Altered State. The driver for the reclamation pathway is weed management without reseeding. Continued Integrated Pest Management (IPM) will be required as many of the invasive species that can occupy the Invaded State have extended dormant seed life. The trigger is invasive species control.

Conservation practices

Brush Management
Prescribed Burning
Prescribed Grazing

Restoration pathway R4A
State 1.4 to 1.3

If invasive species are removed the site could return to the Degraded Shortgrass State (3). Without sufficient remnant populations of preferred plants the Invaded State (4) is not likely to return to any of the other states. The driver for the reclamation pathway is weed management without reseeding. The trigger is invasive species control. The invading species cause a significant increased soil loss due to lack of ground cover (Lacey et al. 1989).

Conservation practices

Brush Management
Prescribed Burning
Integrated Pest Management (IPM)
Prescribed Grazing

State 2
Cultivated State

Native rangeland is converted to a Cultivated system dominated by introduced species for forage or grain production. This system often receives multiple inputs including fertilizer, herbicides, and irrigation.

Characteristics and indicators. Site is sodbusted and converted to forage or grain production

State 2.1
Cultivated Forage Community

The Cultivated Forage Community is the most common within the Cultivated State. It consists primarily of long-term grass or forb crop planted for grazing or hay. If irrigation water is available, species will be highly variable based on the goals and objectives of the land manager; however, alfalfa is likely included. Production of an irrigated site in this community is typically high. If irrigation is not available, the dry climate limits species options and will likely include Crested wheatgrass or Russian wildrye. Alfalfa is rarely a lone species under dryland conditions.

State 2.2
Abandoned Cultivated Field

The Abandoned Cultivated Field Community is a relatively rare occurrence due to the productive nature of this ecological site. However, as traditional land use transitions from agriculture to recreation, abandonment of cultivation may occur. If the site was in the Actively Cultivated State at the time of abandonment, the resulting plant community will likely transition into an herbaceous annual weed community. Over time, the weeds will typically yield to a naturalized community of perennial grasses and forbs sourced from the surrounding plant community. Needle and thread, blue grama, Sandberg bluegrass, rabbitbrush, and fringed sagewort are the common native species that can be considered colonizing species. Active Cultivated States are rarely abandoned without some attempt of being planted to a Cultivated Forage Community first. If the site was managed as a Cultivated Forage Community at the time of abandonment, the plant community tends to transition into a community that resembles a Degraded State over time. With enough time, native colonizing species will slowly fill the interspaces between the forage crops. Once the Abandoned Cultivated Field Community has reached maturity, it will have similar ecological processes as the Degraded State (3.1)

State 2.3
Active Cultivated Community

Active Cultivated Community is common on this ecological site as the soil pH, water holding capacity and inherent soil organic matter tend to be favorable to annual cropping. If irrigation is available this community is capable of producing a wide variety of crops including corn silage, seed potatoes, pumpkins, sunflower, and other specialty crops. The relatively short growing season tends to be the restriction if irrigated. Long-term annual cropping can destroy soil aggregation, create soil erosion (both wind and water), deplete organic matter, and alter pH so a conservative crop management system will need to be applied to prevent degradation of the site.

Transition T1A **State 2.1 to 2.2**

Cultivated Forage Community is abandoned. This pathway rarely occurs in present time however has occurred frequently in the past which is how Community 5.2 may be observed. In this process, a reason for abandonment occurs and the field sits idle from management. Over time the surrounding native vegetation fills the interspaces between plants.

Transition T1B **State 2.1 to 2.3**

Cultivated Forage Community is converted from permanent cover to an annually cropped system. Change takes place when cultivation or plowing occurs. This community pathway is a frequent occurrence on this ecological site particularly when the Cultivated Forage Community's production begins to drop. This is often on a 10-20year cycle in this MLRA.

Transition T2A **State 2.2 to 2.1**

Abandoned Cultivated Field is planted to a forage or hay crop of the manager's preference. Often this pathway will require tillage or herbicide to terminate the existing plant community and seeding to initiate change.

Transition T2B **State 2.2 to 2.3**

An abandoned cultivated field is converted to an annually cropped system. Change takes place when cultivation or plowing occurs. This community pathway is often necessary to convert a lower producing or undesirable community into an annually cropped system.

Transition T3A **State 2.3 to 2.1**

Active Cultivation Community is planted to a forage or hay crop of the manager's preference. This is a common pathway in this MLRA.

Transition T3B **State 2.3 to 2.2**

Active Community is abandoned. This pathway rarely occurs in present time however has occurred frequently in the past which is how Community 5.2 may be observed. In this process, a reason for abandonment occurs and the field sits idle from management. Over time the surrounding native vegetation fills the interspaces between weedy, herbaceous plants

Conversion C1 **Land use 1 to 2**

Native rangeland is converted via tillage for production of forage crop or grains.

Additional community tables

Table 8. Community 1.1 plant community composition

Group	Common Name	Symbol	Scientific Name	Annual Production (Lb/Acre)	Foliar Cover (%)
Grass/Grasslike					
1				994–1463	
	bluebunch wheatgrass	PSSP6	<i>Pseudoroegneria spicata</i>	530–1365	25–40
	needle and thread	HECO26	<i>Hesperostipa comata</i>	66–293	10–15
	green needlegrass	NAVI4	<i>Nassella viridula</i>	133–293	10–15
	basin wildrye	LECI4	<i>Leymus cinereus</i>	0–230	0–10
	Indian ricegrass	ACHY	<i>Achnatherum hymenoides</i>	0–195	0–5
	Grass, perennial	2GP	<i>Grass, perennial</i>	0–155	0–3
	squirreltail	ELEL5	<i>Elymus elymoides</i>	0–20	0–3
2				133–195	
	thickspike wheatgrass	ELLA3	<i>Elymus lanceolatus</i>	0–195	0–3
	western wheatgrass	PASM	<i>Pascopyrum smithii</i>	0–195	0–3
	prairie Junegrass	KOMA	<i>Koeleria macrantha</i>	13–98	0–5
	Sandberg bluegrass	POSE	<i>Poa secunda</i>	13–98	0–5
	needleleaf sedge	CADU6	<i>Carex duriuscula</i>	13–98	0–2
	threadleaf sedge	CAFI	<i>Carex filifolia</i>	0–98	0–1
	plains reedgrass	CAMO	<i>Calamagrostis montanensis</i>	0–98	0–1
	blue grama	BOGR2	<i>Bouteloua gracilis</i>	0–20	0–1
	sand dropseed	SPCR	<i>Sporobolus cryptandrus</i>	0–20	0–1
	Grass-like, perennial	2GLP	<i>Grass-like, perennial</i>	0–10	0–1
	Grass, perennial	2GP	<i>Grass, perennial</i>	0–10	0–1
Forb					
3				66–98	
	common yarrow	ACMI2	<i>Achillea millefolium</i>	0–98	0–1
	dotted blazing star	LIPU	<i>Liatris punctata</i>	13–98	0–1
	ballhead sandwort	ARCO5	<i>Arenaria congesta</i>	13–98	0–1
	bastard toadflax	COUM	<i>Comandra umbellata</i>	0–98	0–1
	Missouri goldenrod	SOMI2	<i>Solidago missouriensis</i>	0–98	0–1
	fleabane	ERIGE2	<i>Erigeron</i>	13–98	0–1
	buckwheat	ERIOG	<i>Eriogonum</i>	13–98	0–1
	hairy false goldenaster	HEVI4	<i>Heterotheca villosa</i>	13–98	0–1
	stiffleaf penstemon	PEAR2	<i>Penstemon aridus</i>	13–98	0–1
	spiny phlox	PHHO	<i>Phlox hoodii</i>	0–98	0–1
	scarlet globemallow	SPCO	<i>Sphaeralcea coccinea</i>	13–98	0–1
	American vetch	VIAM	<i>Vicia americana</i>	13–98	0–1
	cinquefoil	POTEN	<i>Potentilla</i>	0–98	0–1
	desertparsley	LOMAT	<i>Lomatium</i>	13–50	0–1
	onion	ALLIU	<i>Allium</i>	0–20	0–1
	Forb, annual	2FA	<i>Forb, annual</i>	0–20	0–1
	Forb, dicot, perennial	2FDP	<i>Forb, dicot, perennial</i>	0–20	0–1
	Drummond's milkvetch	ASDR3	<i>Astragalus drummondii</i>	0–20	0–1
	milkvetch	ASTRA	<i>Astragalus</i>	0–20	0–1

	THIRVEG01	ARTR2	ARTR2	133-195	3-13
Shrub/Vine					
4				133-195	
	big sagebrush	ARTR2	<i>Artemisia tridentata</i>	66-195	3-13
	winterfat	KRLA2	<i>Krascheninnikovia lanata</i>	13-156	1-3
	rubber rabbitbrush	ERNA10	<i>Ericameria nauseosa</i>	0-38	0-2
	yellow rabbitbrush	CHVI8	<i>Chrysothamnus viscidiflorus</i>	13-38	0-2
	spineless horsebrush	TECA2	<i>Tetradymia canescens</i>	0-38	0-1
	prairie sagewort	ARFR4	<i>Artemisia frigida</i>	0-20	0-1
	broom snakeweed	GUSA2	<i>Gutierrezia sarothrae</i>	0-20	0-1
	plains pricklypear	OPPO	<i>Opuntia polyacantha</i>	0-20	0-1
	Shrub, other	2S	<i>Shrub, other</i>	0-20	0-1
	silver sagebrush	ARCA13	<i>Artemisia cana</i>	0-20	0-1

Animal community

The Loamy ecological site provides a variety of wildlife habitat for an array of species. Prior to the settlement of this area, large herds of antelope, elk, and bison roamed. Though the bison have been replaced, mostly with domesticated livestock, elk and antelope still frequently utilize this largely intact landscape for winter habitat in areas adjacent to forests.

The relatively high grass component of the Reference Community provides excellent nesting cover for multiple neotropical migratory birds that select for open grasslands, such as the long-billed curlew and McCown's longspur.

Greater sage grouse may be present on sites with suitable habitat, typically requiring a minimum of 15 percent sagebrush canopy cover (Wallestad 1975). The Bluebunch Community (1.1) is likely to have minimal sage grouse presence given its low sagebrush canopy cover. However, the potentially diverse forb component of the Bunchgrass State may provide important early-season (spring) foraging habitat for the greater sage grouse. Other communities on the site with sufficient sagebrush cover may harbor sage grouse populations, specifically Community 2.1, where big sagebrush populations are under a reduced fire regime. Also, as sagebrush canopy cover increases under the Altered State and, to a limited extent, the Degraded State 3.1, pygmy rabbit, Brewer's sparrow, and Mule deer use may also increase.

Managed livestock grazing is suitable on this site due to the potential to produce an abundance of high-quality forage. This is often a preferred site for grazing by livestock, and animals tend to congregate in these areas. To maintain the productivity of the Loamy ecological site, grazing on adjacent sites with lower productivity must be carefully managed to ensure that utilization on this site is not excessive. Management objectives should include maintenance or improvement of the native plant community. Careful management of the timing and duration of grazing is important. Shorter grazing periods and adequate deferment during the growing season are recommended for plant maintenance, health, and recovery. According to McLean et al., early-season defoliation of bluebunch wheatgrass can result in high mortality and reduced vigor in plants. They also suggest, based on prior studies, that regrowth is necessary before dormancy to reduce injury to bluebunch.

Since needle and thread normally matures earlier than bluebunch wheatgrass and produces a sharp awn, this species is usually avoided after seed set. Changing the grazing season of use will help utilize needle and thread more efficiently while preventing overuse of bluebunch wheatgrass.

The grazing season has a greater impact on winterfat than grazing intensity. Late winter or early spring grazing is detrimental. However, early winter grazing may actually be beneficial (Blaisdell 1984).

Continual non-prescribed grazing of this site will be detrimental, will alter the plant composition and production over time, and will result in the transition to the Altered State. The transition to other states will depend on the duration of poorly managed grazing as well as other circumstances such as weather conditions and fire frequency.

If the Altered State is subject to further degradation to the Degraded State or Invaded State. Management should focus on grazing management strategies that will prevent further degradation, such as seasonal grazing deferment or winter grazing where feasible. Communities within this state are still stable and healthy under proper management. Forage quantity and/or quality may be significantly reduced when compared to the Bunchgrass State.

Grazing is possible in the Invaded State. Invasive species are generally less palatable than native grasses. Forage production is typically greatly reduced in this state. Due to the aggressive nature of invasive species, sites in the Invaded State face an increased risk of further degradation of the invasive communities. Grazing has to be carefully managed to avoid further soil loss and degradation and possible livestock health issues.

Prescriptive grazing can be used to manage invasive species. In some instances, carefully targeted grazing (sometimes in combination with other treatments) can reduce or maintain the species composition of invasive species. Grazing is possible in a degraded state, but it is generally not economically or environmentally sustainable.

Hydrological functions

The hydrologic cycle functions best in the Bunchgrass State (1) with good infiltration and deep percolation of rainfall; however, the cycle degrades as the vegetation community declines. Rapid rainfall infiltration, high soil organic matter, good soil structure, and good porosity accompany high bunchgrass canopy cover (Thurow et al. 1986). High ground cover reduces raindrop impact on the soil surface, which keeps erosion and sedimentation transport low. Water leaving the site will have a minimal sediment load, which allows for high water quality in associated streams. High rates of infiltration will allow water to move below the rooting zone during periods of heavy rainfall. The Bluebunch Wheatgrass Community (1.1) should have no rills or gullies present, and drainage ways should be vegetated and stable. Water flow patterns, if present, will be barely observable. Plant pedestals are essentially nonexistent. Plant litter remains in place and is not moved by wind or water.

In the Shortgrass Community (2.2), the Degraded State (3), and the Invaded State (4), canopy and ground cover are greatly reduced compared to the Bunchgrass State (1), which impedes the hydrologic cycle. Infiltration will decrease and runoff will increase due to reduced ground cover, the presence of shallow-rooted species, rainfall splash, soil capping, reduced organic matter, and poor structure. Sparse ground cover and decreased infiltration can combine to increase the frequency and severity of flooding within a watershed. Soil erosion is accelerated, the quality of surface runoff is poor, and sedimentation increases. (McCalla et al., 1984)

Recreational uses

This site provides some limited recreational opportunities for hiking, horseback riding, big game and upland bird hunting. Some forbs have flowers that appeal to photographers. This site provides valuable open space.

Wood products

none

Other products

none

Inventory data references

Information presented was derived from the site's Range Site Description (Loamy 9 –14" P.Z., Northern Rocky Mountain Valleys, South, East of Continental Divide), NRCS clipping data, literature, field observations, and personal contacts with range-trained personnel (i.e., used professional opinion of agency specialists, observations of land managers, and outside scientists).

References

. Fire Effects Information System. <http://www.fs.fed.us/database/feis/>.

. 2021 (Date accessed). USDA PLANTS Database. <http://plants.usda.gov>.

Arno, S.F. and G.E. Gruell. 1982. Fire History at the Forest-Grassland Ecotone in Southwestern Montana. *Journal of Range Management* 36:332–336.

Barrett, H. 2007. *Western Juniper Management: A Field Guide*.

Bestelmeyer, B., J.R. Brown, J.E. Herrick, D.A. Trujillo, and K.M. Havstad. 2004. Land Management in the American Southwest: a state-and-transition approach to ecosystem complexity. *Environmental Management* 34:38–51.

Bestelmeyer, B. and J. Brown. 2005. State-and-Transition Models 101: A Fresh look at vegetation change.

Blaisdell, J.P. 1958. Seasonal development and yield of native plants on the Upper Snake River Plains and their relation to certain climate factors.

Blaisdell, J.P. and R.C. Holmgren. 1984. Managing Intermountain Rangelands--Salt-Desert Shrub Ranges. General Tech Report INT-163. USDA Forest Service, Intermountain Forest and Range Experiment Station, Ogden, UT. 52.

Bunting, S.C., B.M. Kilgore, and C.L. Bushey. 1987. Guidelines for Prescribe burning sagebrush-grass rangelands in the Northern Great Basin. General Technical Report INT-231. USDA Forest Service Intermountain Research Station, Ogden, UT. 33.

Colberg, T.J. and J.T. Romo. 2003. Clubmoss effects on plant water status and standing crop. *Journal of Range Management* 56:489–495.

Daubenmire, R. 1970. *Steppe vegetation of Washington*.

DiTomaso, J.M. 2000. Invasive weeds in Rangelands: Species, Impacts, and Management. *Weed Science* 48:255–265.

Dormaar, J.F., B.W. Adams, and W.D. Willms. 1997. Impacts of rotational grazing on mixed prairie soils and vegetation. *Journal of Range Management* 50:647–651.

Hobbs, J.R. and S.E. Humphries. 1995. An integrated approach to the ecology and management of plant invasions. *Conservation Biology* 9:761–770.

Kuchler, A.W. 1964. *Potential natural vegetation of the conterminous United States*.

Lacey, J.R., C.B. Marlow, and J.R. Lane. 1989. Influence of Spotted knapweed (*Centaurea maculosa*) on surface runoff and sediment yield.. *Weed Technology* 3:627–630.

Lesica, P. and S.V. Cooper. 1997. Presettlement vegetation of Southern Beaverhead County, MT.

- Manske, L.L. 1980. Habitat, phenology, and growth of selected sandhills range plants.
- Masters, R. and R. Sheley. 2001. Principles and practices for managing rangeland invasive plants. *Journal of Range Management* 38:21–26.
- McCalla, G.R., W.H. Blackburn, and L.B. Merrill. 1984. Effects of Livestock Grazing on Infiltration Rates of the Edwards Plateau of Texas. *Journal of Range Management* 37:265–269.
- McLean, A. and S. Wikeem. 1985. Influence of season and intensity of defoliation on bluebunch wheatgrass survival and vigor in southern British Columbia. *Journal of Range Management* 38:21–26.
- Miller, R.F., T.J. Svejcar, and J.A. Rose. 2000. Impacts of western juniper on plant community composition and structure. *Journal of Range Management* 53:574–585.
- Moulton, G.E. and T.W. Dunlay. 1988. *The Journals of the Lewis and Clark Expedition*. Pages in University of Nebraska Press.
- Mueggler, W.F. and W.L. Stewart. 1980. *Grassland and Shrubland Habitat Types of Western Montana*.
- Pelant, M., P. Shaver, D.A. Pyke, and J.E. Herrick. 2005. Interpreting Indicators of Rangeland Health.
- Pellant, M. and L. Reichert. 1984. Management and Rehabilitation of a burned winterfat community in Southwestern Idaho. Proceedings--Symposium on the biology of Atriplex and related Chenopods. 1983 May 2-6; Provo UT General Technical Report INT-172.. USDA Forest Service Intermountain Forest and Range Experiment Station. 281–285.
- Pitt, M.D. and B.M. Wikeem. 1990. Phenological patterns and adaptations in an Artemisia/Agropyron plant community. *Journal of Range Management* 43:350–357.
- Pokorny, M.L., R. Sheley, C.A. Zabinski, R. Engel, T.J. Svejcar, and J.J. Borkowski. 2005. Plant Functional Group Diversity as a Mechanism for Invasion Resistance.
- Wambolt, C. and G. Payne. 1986. An 18-Year Comparison of Control Methods for Wyoming Big Sagebrush in Southwestern Montana. *Journal of Range Management* 39:314–319.
- West, N.E. 1994. Effects of Fire on Salt-Desert shrub rangelands. Proceedings--Ecology and Management of Annual Rangelands: 1992 May 18-22. Boise ID General Technical Report INT-GTR-313.. USDA Forest Service Intermountain Research Station. 71–74.
- Whitford, W.G., E.F. Aldon, D.W. Freckman, Y. Steinberger, and L.W. Parker. 1989. Effects of Organic Amendments on Soil Biota on a Degraded Rangeland. *Journal of Range Management* 41:56–60.
- Wilson, A.M., G.A. Harris, and D.H. Gates. 1966. Cumulative Effects of Clipping on Yield of Bluebunch wheatgrass. *Journal of Range Management* 19:90–91.

Contributors

Petersen
Synergy, Ricketts, Gibbons

Approval

Kirt Walstad, 9/11/2023

Rangeland health reference sheet

Interpreting Indicators of Rangeland Health is a qualitative assessment protocol used to determine ecosystem condition based on benchmark characteristics described in the Reference Sheet. A suite of 17 (or more) indicators are typically considered in an assessment. The ecological site(s) representative of an assessment location must be known prior to applying the protocol and must be verified based on soils and climate. Current plant community cannot be used to identify the ecological site.

Author(s)/participant(s)	G. Petersen
Contact for lead author	grant.petersen@usda.gov
Date	10/30/2018
Approved by	Kirt Walstad
Approval date	
Composition (Indicators 10 and 12) based on	Annual Production

Indicators

- 1. Number and extent of rills:** Rills are not present in the reference condition.

- 2. Presence of water flow patterns:** Water flow patterns are not present in the reference condition.

- 3. Number and height of erosional pedestals or terracettes:** Pedestals are not evident in the reference condition.

- 4. Bare ground from Ecological Site Description or other studies (rock, litter, lichen, moss, plant canopy are not bare ground):** Bare ground is low (5-10 percent). It consists of small, randomly scattered patches.

- 5. Number of gullies and erosion associated with gullies:** No gullies present

- 6. Extent of wind scoured, blowouts and/or depositional areas:** None

- 7. Amount of litter movement (describe size and distance expected to travel):** Litter movement is not evident in the reference condition.

8. **Soil surface (top few mm) resistance to erosion (stability values are averages - most sites will show a range of values):** Soil surface stable with ratings of 4 to 6 under both canopy and interspaces. In areas of dense sagebrush, ratings may be lower. Abiotic crusts or root mats may be present. Typical A horizon is 6-8 inches thick.
-
9. **Soil surface structure and SOM content (include type of structure and A-horizon color and thickness):** Soil Structure at the surface is typically strong to medium fine granular. A Horizon should be 6-8 inches thick with color, when wet, typically ranging in Value of 3 or less and Chroma of 3 or less. Local geology may affect color in which it is important to reference the Official Series Description (OSD) for characteristic range.
-
10. **Effect of community phase composition (relative proportion of different functional groups) and spatial distribution on infiltration and runoff:** Evenly distributed across the site, bunchgrasses improve infiltration while rhizomatous grass protects the surface from runoff forces. Infiltration of the Loamy ecological site is well drained but has a slow infiltration rate. An even distribution of Mid-Statured Bunchgrasses (75-80%), cool season rhizomatous grasses (5-10%) along with a mix of Shortgrasses (5-10%), forbs (1-10%), shrubs (1-10%), and Subshrubs (1-10%)
-
11. **Presence and thickness of compaction layer (usually none; describe soil profile features which may be mistaken for compaction on this site):** A compaction layer is not present in the reference condition. Soil profile may contain an abrupt transition to an Argillic horizon which can be misinterpreted as compaction, however, the soil structure will be fine to medium subangular blocky, where a compaction layer will be platy or structureless (massive).
-
12. **Functional/Structural Groups (list in order of descending dominance by above-ground annual-production or live foliar cover using symbols: >>, >, = to indicate much greater than, greater than, and equal to):**
- Dominant: Mid-statured, cool season, perennial bunchgrasses (example list: Bluebunch, green needlegrass, basin wildrye)
- Sub-dominant: rhizomatous = short grasses \geq shrubs = forbs > warm season grasses
- Other: Annual native forbs and grasses may be present in extremely limited amounts
- Additional:
-
13. **Amount of plant mortality and decadence (include which functional groups are expected to show mortality or decadence):** Little evidence of mortality on any species.
-
14. **Average percent litter cover (%) and depth (in):** Total litter cover ranges from 45 to 65%. Most litter is irregularly distributed on the soil surface and is often less than 0.5 inches deep.
-
15. **Expected annual annual-production (this is TOTAL above-ground annual-production, not just forage annual-production):** Average annual production is 1550. Low: 1325 High 1950. Production varies based on effective precipitation and natural variability of soil properties for this ecological site.
-

16. **Potential invasive (including noxious) species (native and non-native).** List species which BOTH characterize degraded states and have the potential to become a dominant or co-dominant species on the ecological site if their future establishment and growth is not actively controlled by management interventions. Species that become dominant for only one to several years (e.g., short-term response to drought or wildfire) are not invasive plants. Note that unlike other indicators, we are describing what is NOT expected in the reference state for the ecological site: Potential invasive (including noxious) species (native and non-native). Invasive species on this ecological site include (but not limited to) dandelion, annual brome spp., spotted knapweed, yellow toadflax, leafy spurge, ventenata, crested wheatgrass, etc.

Native species with the ability to indicate degradation however species presence alone does not imply degradation: Sandberg bluegrass (*Poa secunda*), Big sagebrush (*Artemisia tridentata*), Spineless horsebrush (*Tetradymia canescens*), Broom snakeweed (*Gutierrezia sarothrae*), Rubber rabbitbrush (*Ericameria nauseosa*), Yellow rabbitbrush (*Chrysothamnus viscidiflorus*), Rocky Mountain Juniper (*Juniperus scopulorum*), Douglas fir (*Psuedotsuga menziesii*), Ponderosa pine (*Pinus ponderosa*)

17. **Perennial plant reproductive capability:** In the reference condition, all plants are vigorous enough for reproduction either by seed or rhizomes in order to balance natural mortality with species recruitment.
-