

Ecological site EX044B01A131

Shallow Clay (SwC) LRU 01 Subset A

Last updated: 9/08/2023
Accessed: 04/23/2024

General information

Provisional. A provisional ecological site description has undergone quality control and quality assurance review. It contains a working state and transition model and enough information to identify the ecological site.

MLRA notes

Major Land Resource Area (MLRA): 044B—Central Rocky Mountain Valleys

Major Land Resource Area (MLRA) 44B, Central Rocky Mountain Valleys, is nearly 3.7 million acres of southwest Montana and borders two MLRAs: 43B Central Rocky Mountains and Foothills and 46 Northern and Central Rocky Mountain Foothills.

The major watersheds of this MLRA are those of the Missouri and Yellowstone Rivers and their associated headwaters such as the Beaverhead, Big Hole, Jefferson, Ruby, Madison, Gallatin, and Shields Rivers. These waters allow for extensive irrigation for crop production in an area that would generally only be compatible with rangeland and grazing. The Missouri River and its headwaters are behind several reservoirs that supply irrigation water, hydroelectric power, and municipal water. Limited portions of the MLRA are west of the Continental Divide along the Clark Fork River.

The primary land use of this MLRA is production agriculture (grazing, small grain production, and hay), but there is some limited mining. Urban development is high with large expanses of rangeland converted to subdivisions for a rapidly growing population.

The MLRA consists of one Land Resource Unit (LRU) and seven climate based LRU subsets. These subsets are based on a combination of Relative Effective Annual Precipitation (REAP) and frost free days. Each subset expresses a distinct set of plants that differentiate it from other LRU subsets. Annual precipitation ranges from a low of 9 inches to a high near 24 inches. The driest areas tend to be in the valley bottoms of southwest Montana in the rain shadow of the mountains. The wettest portions tend to be near the edge of the MLRA at the border with MLRA 43B. Frost free days also vary widely from less than 30 days in the Big Hole Valley to around 110 days in the warm valleys along the Yellowstone and Missouri Rivers.

The plant communities of the MRLA are highly variable, but the dominant community is a cool-season grass and shrub-steppe community. Warm-season grasses have an extremely limited extent in this MLRA. Most subspecies of big sagebrush are present, to some degree, across the MLRA.

LRU notes

MLRA 44B has one LRU that covers the entire MLRA. The LRU has been broken into seven climate subsets based on a combination of Relative Effective Annual Precipitation (REAP) and frost free days. Each combination of REAP and frost free days results in a common plant community that is shared across the subset. Each subset is giving a letter designation of A through F for sites that do not receive additional water and Y for sites that receive additional water.

LRU 01 Subset A has a REAP of nine to 14 inches (228.6-355.6mm) with a frost free days range of 70 to 110 days. This combination of REAP and frost free days results in a nearly treeless sagebrush steppe landscape.

The soil moisture regime is Ustic, dry that borders on Aridic and has a Frigid soil temperature regime.

Classification relationships

Mueggler and Stewart. 1980. Grassland and Shrubland habitat types of Western Montana

1. *Stipa comata/Bouteloua gracilis* h.t.
2. *Agropyron spicatum/Bouteloua gracilis* h.t.

Montana Natural Heritage Program Vegetation Classification

1. *Stipa comata - Bouteloua gracilis* Herbaceous Vegetation (STICOM – BOUGRA) Needle and thread/Blue grama
Natural Heritage Conservation Rank-G5 / S5
Edition / Author- 99-11-16 / S.V. Cooper,

EPA Ecoregions of Montana, Second Edition:

- Level I: Northwestern Forested Mountains
- Level II: Western Cordillera
- Level III: Middle Rockies & Northern Great Plains
- Level IV: Paradise Valley
Townsend Basin
Dry Intermontane Sagebrush Valleys
Shield-Smith Valleys

National Hierarchical Framework of Ecological Units:

- Domain: Dry
- Division: M330 – Temperate Steppe Division – Mountain Provinces
- Province: M332 –Middle Rocky Mountain Steppe – Coniferous Forest – Alpine Meadow
- Section: M332D – Belt Mountains Section
M332E – Beaverhead Mountains Section
- Subsection: M332Ej – Southwest Montana Intermontane Basins and Valleys
M332Dk – Central Montana Broad Valleys

Ecological site concept

The Shallow Clay ecological site is an upland site formed from residuum or slope alluvium and is on slopes less than 15 percent. The site does not receive additional moisture from a water table or flooding. It has clay content greater than 35 percent in the upper four (4) inches of the mineral surface. It is shallow and has a root-restrictive layers within 10 to 20 inches (25-50cm). The surface of the site has less than five percent stone cover and is not skeletal, with less than 35 percent rock fragments in the 10 to 20-inch depth. The site does not have a saline or saline-sodic influence and is not strongly or violently effervescent within four inches of the mineral surface. Calcium carbonates may increase with depth.

Associated sites

EX044B01A001	Clayey (Cy) LRU 01 Subset A The Clayey ecological site resides on the neighboring toe slope or hillslope position. Production will be higher on the Clayey site but may express similar plant species.
--------------	--

Similar sites

EX044B01A001	Clayey (Cy) LRU 01 Subset A The Clayey site shares similar Reference Plant community, however produces higher amounts of biomass
EX044B01A136	Shallow Loamy (SwLo) LRU 01 Subset A The Shallow Loamy has a similar state and transition model and response to management, but tends to produce a slightly different plant community

Table 1. Dominant plant species

Tree	(1) <i>Juniperus scopulorum</i> (2) <i>Pinus ponderosa</i>
Shrub	(1) <i>Artemisia tridentata</i>
Herbaceous	(1) <i>Pseudoroegneria spicata</i> (2) <i>Hesperostipa comata</i>

Legacy ID

R044BA131MT

Physiographic features

This ecological site can be found on nearly flat to steep uplands. It often occurs in complexes with other ecological sites, particularly in rougher terrain. This site occurs on all slopes and exposures. Aspect can cause minor changes in the composition and production of plant communities. The amount of exposed rock outcrop tends to increase as slopes increase. Runoff and the potential for water erosion can be significant features of this site.

Table 2. Representative physiographic features

Landforms	(1) Intermontane basin > Hill (2) Intermontane basin > Knoll (3) Intermontane basin > Ridge (4) Intermontane basin > Escarpment
Runoff class	Medium to high
Elevation	4,000–5,000 ft
Slope	2–45%
Aspect	W, NW, N, NE, E, SE, S, SW

Climatic features

The Central Rocky Mountain Valleys MLRA has a continental climate. Fifty to sixty percent of the annual long-term average total precipitation falls between May and August. Snow on frozen ground makes up the majority of winter precipitation. Average precipitation for LRU 01 Subset A is 12 inches (305 mm), and the frost-free period averages 78 days. Precipitation is highest in May and June. Some of Montana's driest areas are located in sheltered mountain valleys because of the rain-shadow effects on the leeward side of some ranges.

Table 3. Representative climatic features

Frost-free period (characteristic range)	40-90 days
Freeze-free period (characteristic range)	93-120 days
Precipitation total (characteristic range)	10-13 in
Frost-free period (actual range)	31-110 days
Freeze-free period (actual range)	70-131 days
Precipitation total (actual range)	10-14 in
Frost-free period (average)	78 days
Freeze-free period (average)	107 days
Precipitation total (average)	12 in

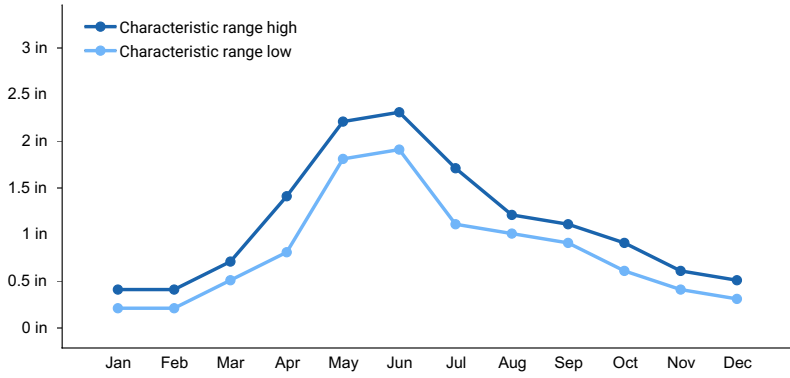

Figure 1. Monthly precipitation range

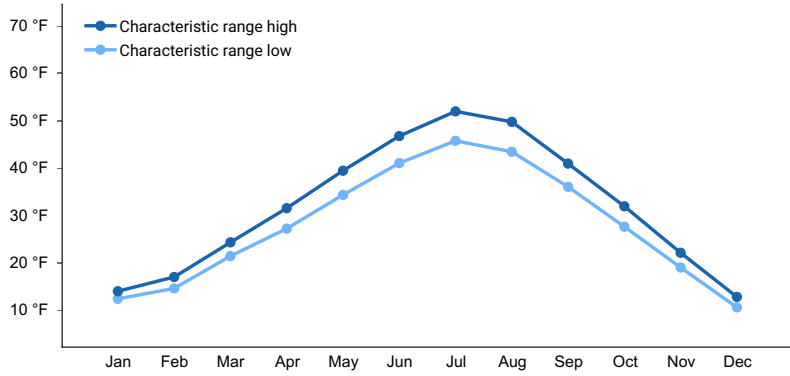

Figure 2. Monthly minimum temperature range

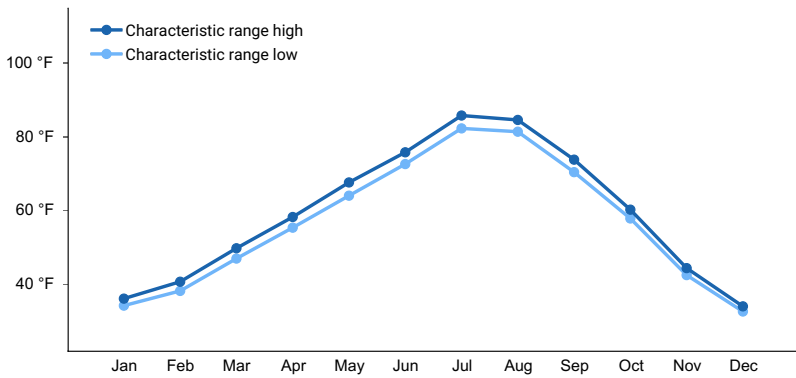

Figure 3. Monthly maximum temperature range

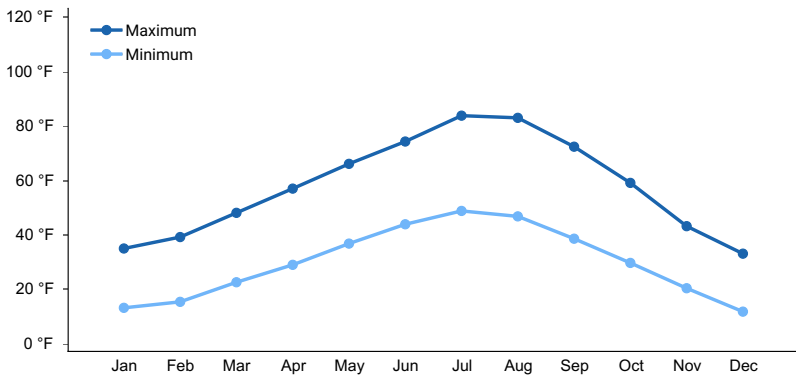

Figure 4. Monthly average minimum and maximum temperature

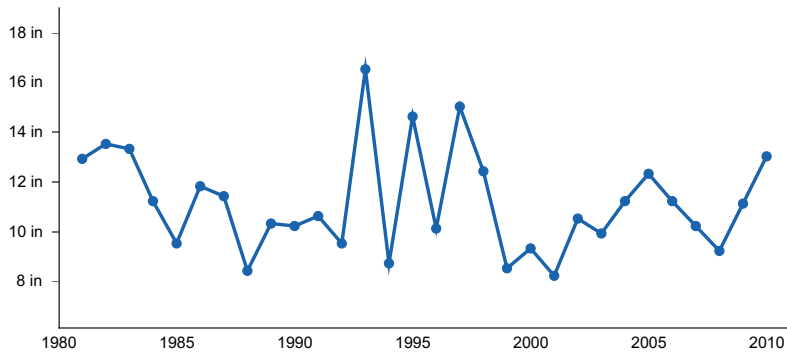

Figure 5. Annual precipitation pattern

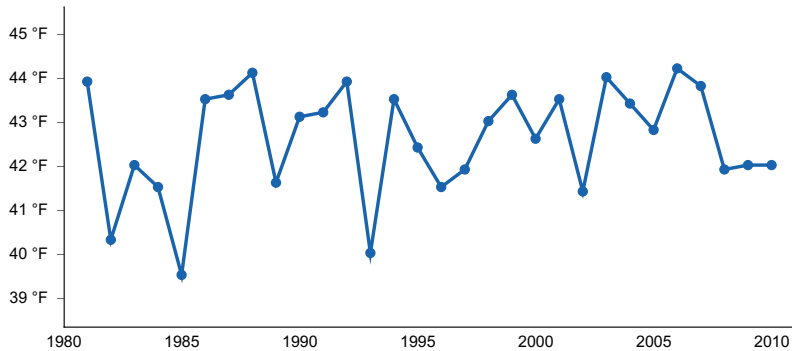

Figure 6. Annual average temperature pattern

Climate stations used

- (1) DEER LODGE 3 W [USC00242275], Deer Lodge, MT
- (2) DILLION U OF MONTANA WESTERN [USC00242409], Dillon, MT
- (3) GLEN 2 E [USC00243570], Dillon, MT
- (4) ENNIS [USC00242793], Ennis, MT
- (5) BOULDER [USC00241008], Boulder, MT
- (6) GARDINER [USC00243378], Gardiner, MT
- (7) TOWNSEND [USC00248324], Townsend, MT
- (8) TRIDENT [USC00248363], Three Forks, MT
- (9) TWIN BRIDGES [USC00248430], Sheridan, MT
- (10) WHITE SULPHUR SPRNGS 2 [USC00248930], White Sulphur Springs, MT
- (11) DILLON AP [USW00024138], Dillon, MT
- (12) HELENA RGNL AP [USW00024144], Helena, MT

Influencing water features

This ecological site has slow permeability and is shallow to bedrock, so runoff tends to be high. Rills and water flow patterns will be conspicuous on steep slopes following extreme runoff events associated with heavy storms.

Wetland description

This site is not associated with wetland characteristics

Soil features

These are shallow clayey soils that are 10 to 20 inches deep and have underlying beds of decomposed shale or nearly impervious clays. These soils are formed from slope alluvium and residuum. The site is well drained with slow permeability. The typical soil surface texture is silty clay loam, with clay content in the top 4 inches exceeding 32 percent. The current soil series is almost entirely Shoddy.

Table 4. Representative soil features

Parent material	(1) Residuum–sedimentary rock (2) Slope alluvium–sedimentary rock
Surface texture	(1) Clay loam (2) Silty clay loam (3) Sandy clay loam
Family particle size	(1) Clayey
Drainage class	Moderately well drained to well drained
Permeability class	Moderately slow to slow
Depth to restrictive layer	10–20 in
Soil depth	10–20 in
Available water capacity (0-20in)	2.6–3.1 in
Calcium carbonate equivalent (0-20in)	10%
Clay content (0-4in)	32%
Soil reaction (1:1 water) (0-20in)	7.4–9

Ecological dynamics

Shallow Clay ecological site occurs across a relatively small landscape; slight variations within the plant community may occur due to aspect, elevation, and relative effective annual precipitation; however, this is quite limited.

The reference plant community is dominated by bluebunch wheatgrass (*Pseudoroegneria spicata*) and western wheatgrass (*Pascopyrum smithii*). Subdominant species may include green needlegrass (*Nassella viridula*), needle and thread (*Hesperostipa comata*), Wyoming big sage (*Artemisia tridentata* ssp. *wyomingensis*), winterfat (*Krascheninnikovia lanata*), and Indian ricegrass (*Achnatherum hymenoides*).

Large scale coniferous expansion has occurred on this and neighboring ecological sites. Up to two coniferous trees per acre may exist on this ecological site though tree canopy should be localized to small patches. The common tree species may include Rocky Mountain juniper (*Juniperus scopulorum*), ponderosa pine (*Pinus ponderosa* var *scopulorum*), or Douglas fir (*Pseudotsuga menziesii*).

Wyoming big sagebrush steppe communities historically had low fuel loadings and were characterized by 10- to 70-year interval, fires that produced a mosaic of burned and unburned lands (Bunting et al., 1987). A shift to the dominance of shrubs may occur in response to improper grazing management, drought, or due to a lack of fire. Shrub encroachment by a variety of species, including broom snakeweed (*Gutierrezia sarothrae*), fringed sagewort (*Artemisia frigida*), Wyoming big sagebrush (*Artemisia tridentata* ssp. *wyomingensis*), rubber rabbitbrush (*Ericameria nauseosa*), yellow rabbitbrush (*Chrysothamnus viscidiflorus*), and plains prickly pear (*Opuntia polyacantha*) occurs within this site as the mid-stature bunchgrasses decrease. Shrub dominance and grass loss can be associated with soil erosion and, ultimately, thinning of the native soil surface. Subsequent loss of soil could lead to a Degraded State. All states could also lead to the Invaded State when there is a lack of weed prevention and control measures.

Historical records indicate that, prior to the introduction of livestock (cattle and sheep) during the late 1800s, elk and bison grazed this ecological site. Due to bison's nomadic nature and herd structure, grazed areas received periodic high intensity, short duration grazing pressure. Forage for livestock was noted as minimal in areas recently grazed by bison (Lesica and Cooper 1997). Meriwether Lewis documented that he was met by 60 Shoshone warriors on horseback in August 1805, and the Corps of Discovery was later supplied with horses by the same band of Shoshone. This suggests that the areas near the modern-day Montana towns of Twin Bridges, Dillon, Grant, and Dell were grazed by an untold number of horses prior to the large introduction of cattle and sheep. Livestock grazing has occurred on most of this ecological site in southwestern Montana for more than 150 years. The gold

boom in the 1860s brought the first herds of livestock overland from Texas, and homesteaders began settling the area. During this time, cattle were the primary domestic grazers in the area. In the 1890s, Montana sheep production began to increase and dominated the livestock industry until the 1930s. Since the 1930s, cattle production has dominated the livestock industry in the region (Wyckoff and Hansen 2001).

Natural and prescribed fire, both used by indigenous peoples, were major ecological drivers of not only this ecological site but the entire MLRA. Indigenous peoples have utilized fire on this ecological site for thousands of years prior to European settlement as a means to move wildlife populations for harvest (Roos, Christopher I., et al. 2018). Fire tended to restrict tree and shrub growth to small patches and promote an herbaceous plant community. The natural fire return interval was highly variable, but it was likely shorter than 30 years. With the historically recent (since 1910) suppression of fire, shrubs and coniferous trees have increased significantly.

Some of the major invasive species that can occur on this site include (but are not limited to) spotted knapweed (*Centaurea stoebe*), leafy spurge (*Euphorbia esula*), cheatgrass (*Bromus tectorum*), field brome (*Bromus arevensis*), yellow toadflax (*Linaria vulgaris*), and dandelion (*Taraxicum* spp.). Invasive weeds are beginning to have a high impact on this ecological site.

Plant Communities and Transitions

A state and transition model for this ecological site is depicted below. Thorough descriptions of each state, transition, plant community, and pathway follow the model. This model is based on available experimental research, field data, field observations, and interpretations by experts. It is likely to change as knowledge increases.

The plant communities within the same ecological site will differ across the MLRA due to the naturally occurring variability in weather, soils, and aspect. The biological processes on this site are complex; therefore, representative values are presented in a land management context. The species lists are representative and are not botanical descriptions of all species occurring, or potentially occurring, on this site. They are intended to cover the core species and the known range of conditions and responses.

Although there is considerable qualitative experience supporting the pathways and transitions within the state and transition model (STM), no quantitative information exists that specifically identifies threshold parameters between grassland types and invaded types in this ecological site. For information on STMs, see the following citations: Bestelmeyer et al. (2003), Bestelmeyer et al. (2004), Bestelmeyer and Brown (2005), and Stringham et al. (2003).

State and transition model

Ecosystem states

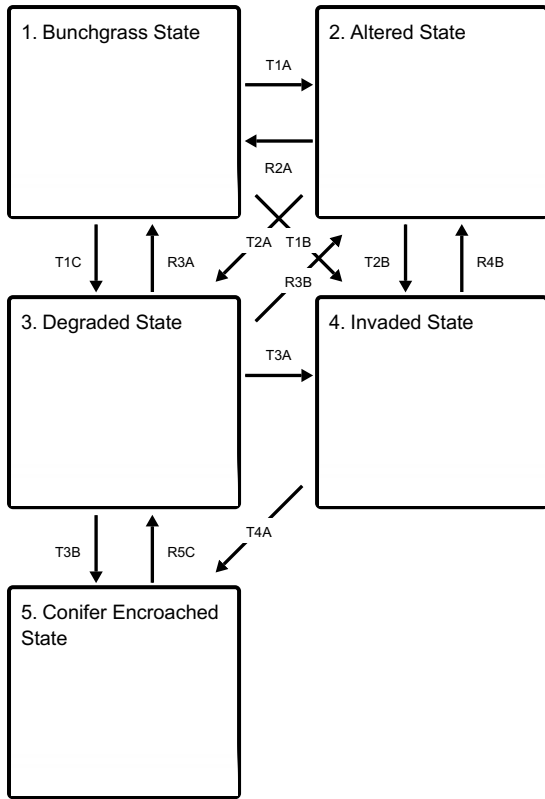

States 1, 5 and 2 (additional transitions)

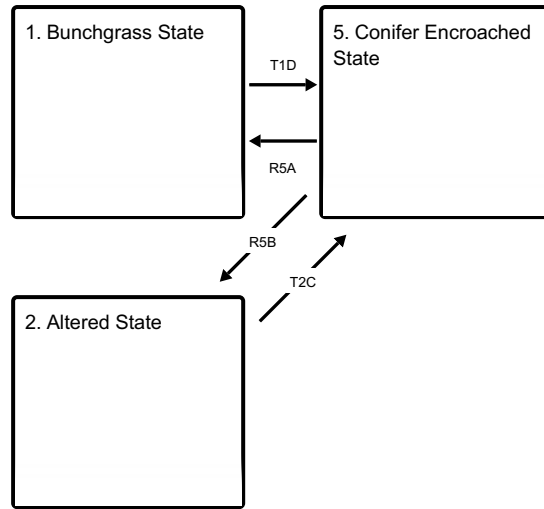

State 1 submodel, plant communities

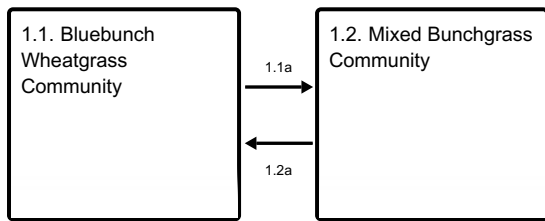

State 2 submodel, plant communities

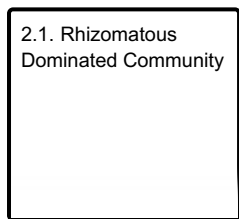

State 3 submodel, plant communities

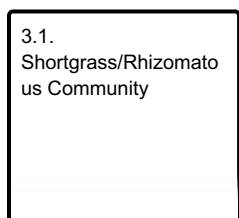

State 4 submodel, plant communities

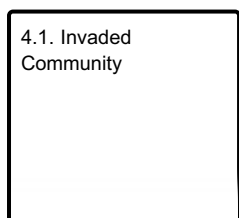

State 5 submodel, plant communities

5.1. Conifer
Community

State 1 Bunchgrass State

The Bunchgrass State of this ecological site consists of two known potential plant communities: the Bluebunch Community (1.1) and the Mixed Bluebunch Community (1.2). These are described below but are generally characterized by a mid-statured, cool-season grass community with limited shrub production. Community 1.1 is dominated by bluebunch wheatgrass and is considered the reference, while Community 1.2 has a codominance of bluebunch and western wheatgrass with a slight increase in green rabbitbrush and Wyoming big sagebrush. These communities may meld into each other due to the varying conditions that occur in southwest Montana, particularly during dry cycles where the needle and thread growth cycle takes better advantage of the limited moisture.

Dominant plant species

- Rocky Mountain juniper (*Juniperus scopulorum*), tree
- ponderosa pine (*Pinus ponderosa*), tree
- Wyoming big sagebrush (*Artemisia tridentata* ssp. *wyomingensis*), shrub
- spineless horsebrush (*Tetradymia canescens*), shrub
- currant (*Ribes*), shrub
- bluebunch wheatgrass (*Pseudoroegneria spicata*), grass
- green needlegrass (*Nassella viridula*), grass
- needle and thread (*Hesperostipa comata*), grass
- hairy false goldenaster (*Heterotheca villosa*), other herbaceous
- curlycup gumweed (*Grindelia squarrosa*), other herbaceous
- dotted blazing star (*Liatris punctata*), other herbaceous
- American vetch (*Vicia americana*), other herbaceous

Community 1.1 Bluebunch Wheatgrass Community

In the Reference Plant Community, bluebunch wheatgrass (*Pseudoroegneria spicata*) and western wheatgrass (*Pascopyrum smithii*) are typically dominant. Green needlegrass (*Nassella viridula*), Indian ricegrass (*Achnatherum hymenoides*), and winterfat (*Krascheninnikovia lanata*) are subordinates in the community. Shrub species (big sagebrush, fringed sagewort, and broom snakeweed) remain a minor part of the community. In some areas, spineless horsebrush (*Tetradymia canescens*) may occupy a small niche. Sandberg bluegrass (*Poa secunda*) and dryland sedges are also common. This state occurs on the Shallow Clay site in areas with proper livestock grazing or in areas with little or no grazing pressure. Bluebunch wheatgrass lacks resistance to grazing during the critical growing season (spring) and will decline in vigor and production if grazed in the critical growing season more than one year in three (Wilson et al. 1960). The Bunchgrass State is moderately resilient and will return to dynamic equilibrium following a relatively short period of stress (such as drought or short-term improper grazing), provided a return of favorable or normal growing conditions and properly managed grazing. As discussed in the Ecological Dynamics section, the natural fire regime restricted shrubs and coniferous trees to relatively small portions of Reference Plant Community 1.1. Shrub species present may include Wyoming big sagebrush, spineless horsebrush, winterfat, tarragon (*Artemisia drucunculus*), and fringed sagewort. Infrequent fire probably maintained big sagebrush communities as open, seral stands of productive herbaceous species with patches of big sagebrush.

Forest overstory. The Shallow Clay ecological site may express up to two (2) stems per acre of Rocky Mountain juniper, ponderosa pine, and/or Douglas fir. This sparse tree cover, which can be expressed as less than 1 percent, is fairly random, with trees growing very slowly. The fire return interval seen on the sagebrush steppe kept tree canopy cover low, and trees rarely reached maturity.

Dominant plant species

- Rocky Mountain juniper (*Juniperus scopulorum*), tree
- ponderosa pine (*Pinus ponderosa* var. *scopulorum*), tree
- Douglas-fir (*Pseudotsuga menziesii*), tree
- Wyoming big sagebrush (*Artemisia tridentata* ssp. *wyomingensis*), shrub
- currant (*Ribes*), shrub
- winterfat (*Krascheninnikovia lanata*), shrub
- yellow rabbitbrush (*Chrysothamnus viscidiflorus*), shrub
- bluebunch wheatgrass (*Pseudoroegneria spicata*), grass
- green needlegrass (*Nassella viridula*), grass
- needle and thread (*Hesperostipa comata*), grass
- Indian ricegrass (*Achnatherum hymenoides*), grass
- dotted blazing star (*Liatris punctata*), other herbaceous
- purple prairie clover (*Dalea purpurea*), other herbaceous
- American vetch (*Vicia americana*), other herbaceous
- curlycup gumweed (*Grindelia squarrosa*), other herbaceous

Table 5. Annual production by plant type

Plant Type	Low (Lb/Acre)	Representative Value (Lb/Acre)	High (Lb/Acre)
Grass/Grasslike	493	723	875
Shrub/Vine	58	84	103
Forb	29	43	52
Tree	0	0	10
Total	580	850	1040

Table 6. Ground cover

Tree foliar cover	0%
Shrub/vine/liana foliar cover	0-3%
Grass/grasslike foliar cover	5-15%
Forb foliar cover	0-3%
Non-vascular plants	0%
Biological crusts	0%
Litter	25-35%
Surface fragments >0.25" and <=3"	0-15%
Surface fragments >3"	0-10%
Bedrock	0%
Water	0%
Bare ground	5-15%

Table 7. Soil surface cover

Tree basal cover	0-1%
Shrub/vine/liana basal cover	10-20%
Grass/grasslike basal cover	35-55%
Forb basal cover	3-5%
Non-vascular plants	0%
Biological crusts	0%

Litter	25-35%
Surface fragments >0.25" and <=3"	0-15%
Surface fragments >3"	0-10%
Bedrock	0%
Water	0%
Bare ground	5-15%

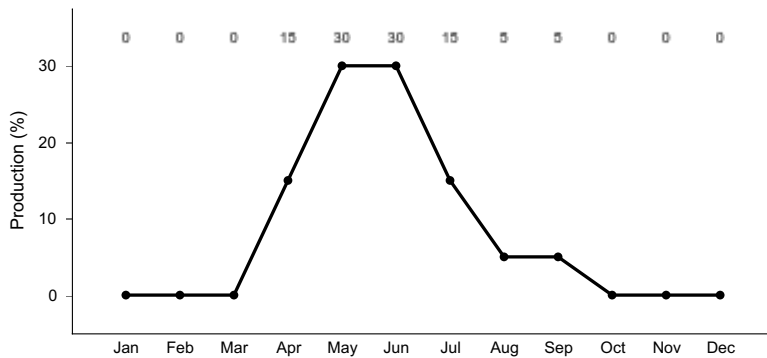

Figure 8. Plant community growth curve (percent production by month). MT44B032, Dry Uplands. Cool season grass dominated system. Most dry, upland sites located within MLRA 44B LRU A are characterized by early season growth which is mostly complete by Mid-July. Limited fall "green-up" if conditions allow..

Community 1.2 Mixed Bunchgrass Community

With proper grazing management over time, the Mixed Bunchgrass Community (1.2) can come close to the diversity and complexity of the Bluebunch Wheatgrass Community (1.1). Without active management, the site is not likely to return to the Bluebunch Wheatgrass Community. Western wheatgrass and needle and thread tolerate grazing pressure better than bluebunch wheatgrass. The growing point for bluebunch wheatgrass is several inches above the ground, making it very susceptible to continued close grazing (Smoliack et al., 2006), while western wheatgrass and needle and thread growing points tend to be near the plant base. These plants increase in composition when more palatable and less grazing tolerant plants decrease due to improper grazing management. Needle and thread, western wheatgrass, and bluebunch wheatgrass share dominance in the Mixed Bunchgrass Community (1.2). Other grass species, which are more tolerant to grazing and are likely to increase in number compared to the Reference Plant Community, include Sandberg bluegrass (*Poa secunda*), prairie Junegrass, thickspike wheatgrass (*Elymus lanceolatus*), and blue grama (*Bouteloua gracilis*). Western yarrow, spiny phlox (*Phlox hoodii*), scarlet globemallow (*Sphaeralcea coccinea*), hairy goldenaster (*Heterotheca villosa*), and pussytoes (*Antennaria* spp.) are examples of increaser forbs. Fringed sagewort (*Artemisia frigida*) is a shrub that also increases under prolonged drought or heavy grazing and can respond to precipitation that falls in July and August. Heavy, continuous grazing will reduce plant cover, litter, and mulch. The timing of grazing is important on this site because of the moisture limitations beyond June, especially on the drier sites. Bare ground will increase, exposing the soil to erosion. Litter and mulch will be reduced as plant cover declines. As long as the production of Bluebunch wheatgrass remains a significant portion of the total biomass production, the site can return to the Bluebunch Wheatgrass Community (Pathway 1.2A) under proper grazing management and favorable growing conditions. Needle and thread and western wheatgrass will continue to increase until they make up 80 percent or more of the grass species composition. It may be difficult for the site to recover to the Reference Plant Community (1.1) once bluebunch wheatgrass has been reduced to less than 15 percent composition. The risk of soil erosion increases when canopy cover decreases below 50 percent. As soil conditions degrade, there will be a loss of organic matter, reduced litter, and reduced soil fertility. Degraded soil conditions increase the difficulty of reestablishing bluebunch wheatgrass and returning to the Reference Community (1.1). The Mixed Bunchgrass Community (1.2) is the at-risk plant community for this ecological site. When overgrazing continues, increaser species such as needle and thread and native forb species will become more dominant, and this triggers the change to the Altered Bunchgrass State (2) or the Degraded Shortgrass State (3). Until the Mixed Bunchgrass Community (1.2) crosses the threshold into the Needle and Thread Community (2.1) or the Invaded Community (4.1), this community can be managed toward the Bluebunch Wheatgrass Community (1.1) using prescribed grazing and strategic weed control (if present). It may

take several years to achieve this recovery, depending on growing conditions, the vigor of remnant bluebunch wheatgrass plants, and the aggressiveness of the weed treatments.

Pathway 1.1a

Community 1.1 to 1.2

Bluebunch wheatgrass loses vigor with improper grazing or extended drought. When vigor declines enough for plants to die or become smaller, species with higher grazing tolerance increase in vigor and production as they access the resources previously used by bluebunch wheatgrass. Decrease of species composition by weight of bluebunch wheatgrass to less than 50 % indicates that the plant community has shifted to the Mixed Bunchgrass Community (1.2). The driver for community shift 1.1A is improper grazing management or prolonged drought. This shift is triggered by the loss of vigor of bluebunch wheatgrass, soil erosion or prolonged drought coupled with improper grazing. Blaisdell (1958) stated that drought and warmer than normal temperatures are known to advance plant phenology by as much as one month. During drought years, plants may be especially sensitive or in a critical stage of development earlier than expected. Since needle-and-thread normally heads out in June and bluebunch wheatgrass in July this should be taken into consideration when planning grazing management.

Pathway 1.2a

Community 1.2 to 1.1

The Mixed Bunchgrass Community (1.2) will return to the Bluebunch Wheatgrass Community (1.1) with proper grazing management and appropriate grazing intensity. Favorable moisture conditions will facilitate or accelerate this transition. It may take several years of favorable conditions for the community to transition back to a bluebunch dominated state. The driver for this community shift (1.2A) is increased vigor of bluebunch wheatgrass to the point that it represents more than 50% of species composition. The trigger for this shift is the change in grazing management favoring bluebunch wheatgrass. In general, conservative grazing management styles such as deferred or rest rotations utilizing moderate grazing (less than 50% use) coupled with favorable growing conditions like cool, wet springs are these triggers. These systems tend to promote increases in soil organic matter which promotes microfauna and can increase infiltration rates. Inversely, long periods of rest at a time when this state is considered to be stable may not result in an increase in bluebunch wheatgrass and it has been suggested (Noy-Meir 1975) that these long periods of rest or underutilization may actually drive the system to a lower level of stability by creating large amounts of standing biomass, dead plant caudex centers, and gaps in the plant canopy.

State 2

Altered State

This state is characterized by having less than 15 percent bluebunch wheatgrass by dry weight. It is represented by one community. Production in this state can be similar to that in the Bunchgrass State (1). Some native plants tend to increase under prolonged drought and heavy grazing practices. A few of these species may include western wheatgrass, needle and thread, Sandberg bluegrass, scarlet globemallow, hairy goldenaster, and fringed sagewort.

Community 2.1

Rhizomatous Dominated Community

Long-term grazing mismanagement with continuous growing-season pressure will reduce total productivity of the site and lead to an increase of bare ground. Once plant cover is reduced, the site is more susceptible to erosion and degradation of soil properties. Soil erosion or reduced soil health will result in reduced plant production. This soil erosion or loss of soil fertility indicates the transition to the Altered Bunchgrass State (2), because it creates a threshold requiring input of energy to return to the Bunchgrass State (1). Transition to the Needle and thread Community (2.1) may be exacerbated by extended drought conditions. Western wheatgrass dominates this community (2.1). Bluebunch wheatgrass makes up less than 10 percent of species composition by dry weight and the remaining bluebunch wheatgrass plants tend to be scattered and low in vigor. Increaser and invader species will be more common and create more competition for bluebunch wheatgrass. This makes it difficult for bluebunch wheatgrass to quickly respond to a change in grazing management alone. Therefore, an input of energy is required for the community to return to the Bunchgrass State (1). Wind and water erosion may be eroding soil from the plant interspaces. Soil fertility is reduced and soil surface erosion resistance has declined compared to the Bunchgrass State (1). This community crossed a threshold compared to the Mixed Bunchgrass Community (1.2) due to the

erosion of soil, vegetation composition, loss of soil fertility, or degradation of soil conditions. This results in a critical shift in the ecology of the site. The effects of soil erosion can alter the hydrology, soil chemistry, soil microorganisms, and soil structure to the point where intensive restoration is required to restore the site to another state or community. Changing grazing management alone cannot create sufficient improvement to restore the site within a reasonable time frame. Dormaar (1997) stated that with decreased grazing pressure a needle and thread/blue grama plant community did not change species composition but the content of the soil carbon increased. It will require a considerable input of energy to move the site back to the Bunchgrass State (1). This state has lost soil or vegetation attributes to the point that recovery to the Bunchgrass State (1) will require reclamation efforts, i.e., soil rebuilding, intensive mechanical treatments, and reseeding. The transition to this state could result from overgrazing, especially repeated early season grazing coupled with extensive drought. If heavy grazing continues, plant cover, litter, and mulch will continue to decrease and bare ground will increase exposing the soil to accelerated erosion. Litter and mulch will move off-site as plant cover declines. The Rhizomatous Dominated Community will then shift to a Degraded Shortgrass State (3). Introduction or expansion of invasive species will further drive the plant community to the Invaded State (4).

State 3 Degraded State

The Degraded State is described by a single plant community consisting of nearly equal components of increaser grasses, shrubs, and forbs. Large patches of bare ground exist, with areas of erosional pedestalling and terracettes common. Dense clubmoss (*Selaginella densa*) exists between plant bases as a reaction to the increased bare ground.

Community 3.1 Shortgrass/Rhizomatous Community

Soil loss continues or increases to the point that native perennial grasses make up less than 250 pounds of annual dry weight production. Grass and forb cover may be very sparse or clumped. Weedy species, annual species, cacti, and shrubs dominate the plant community. Mid-stature perennial bunchgrass species (e.g., needle and thread) may exist, but only in small patches. This could occur due to overgrazing (failure to adjust stocking rates to declining forage production due to increased invasive dominance), a long-term lack of fire (if Wyoming big sagebrush occurs), or the introduction of invasive species. Plant production may be as low as 200 pounds per acre with a significant increase in bare ground. In the most severe stages of degradation, there is a significant amount of bare ground, and large gaps occur between plants. Large patches of prickly pear cactus are common. Potential exists for soils to erode to the point that irreversible damage may occur. This is a critical shift in the ecology of the site. Soil erosion combined with a lack of organic matter deposition due to sparse vegetation creates changes to the hydrology, soil chemistry, soil microorganisms, and soil structure to the point where intensive restoration is required to restore the site to another state or community. Changing management (i.e., improving grazing management) cannot create sufficient change to restore the site within a reasonable time frame. This state is characterized by soil surface degradation and little plant soil surface cover. Shrub canopy cover is usually greater than 15 percent. In this plant community, big sagebrush is replaced with a dominant community of broom snakeweed, rabbitbrush, fringed sagewort, and plains prickly pear cactus. This state has lost soil or vegetation attributes to the point that recovery for the Bunchgrass State will require reclamation efforts, i.e., soil rebuilding, intensive mechanical treatments, and reseeding. This plant community may be in a terminal state and will not return to the reference state because of degraded soil conditions and the loss of higher successional native plant species. Key factors in the approach to transition include a decrease in grass canopy cover and production, an increase in shrub canopy cover, increases in mean bare patch size, increases in soil crusting, decreases in cover of cryptobiotic crusts, decreases in soil aggregate stability, or evidence of erosion, including water flow patterns and litter movement.

State 4 Invaded State

The Invaded State is identified as being in the exponential growth phase of invader abundance where control is a priority. Dominance (or relative dominance) of noxious or invasive species reduces species diversity, forage production, wildlife habitat, and site protection. A level of 15 percent invasive species composition by dry weight indicates that a substantial energy input will be required to create a shift to the grassland state (herbicide, mechanical treatment), even with a return to proper grazing management or favorable growing conditions.

Prescriptive grazing can be used to manage invasive species. In some instances, carefully targeted grazing (sometimes in combination with other treatments) can reduce or maintain the species composition of invasive species. The invaded community within this state will follow a pathway if the invasive or noxious species will continue to thrive without mechanical, biological, or chemical control methods. The invasive nature of the weed outcompetes the present plant community. Once the weed reaches its maximum population level for this site, effective control is unlikely without massive resource inputs. After invading species have established and spread, ecological processes at the site may change (Walker and Smith 1997).

Community 4.1 Invaded Community

Communities in this state may be structurally indistinguishable from the bunchgrass state except that invasive or noxious species exceed 20 percent of species composition by dry weight. This state may also include a community similar to the Degraded State (3) except that invasive or noxious species exceed 20 percent of species composition by dry weight. Although there is no research to document a level of 20 percent, this is estimated to be the point in the invasion process following the lag phase based on the interpretation of Masters and Sheley (2001). For aggressive invasive species (i.e., spotted knapweed), the threshold could be less than 10 percent. Early in the invasion process, there is a lag phase where the invasive plant populations remain small and localized for long periods before expanding exponentially (Hobbs and Humphries 1995). Production in the invaded community may vary greatly. A site dominated by Kentucky bluegrass or spotted knapweed, where soil fertility and chemistry remain near reference, may have production near that of the reference community. A site with degraded soils and an infestation of cheatgrass may produce only 10 to 20 percent of the reference community. Once invasive species dominate the site, either in species composition by weight or in their impact on the community the threshold has been crossed to the Invaded State (4). As invasive species such as spotted knapweed, cheatgrass, and leafy spurge become established, they become very difficult to eradicate. Therefore, considerable effort should be put into preventing plant communities from crossing a threshold into the Invaded State (4) through early detection and proper management. Preventing new invasions is by far the most cost-effective control strategy and typically places an emphasis on education. Control measures used on the noxious plant species impacting this ecological site include chemical, biological, and cultural control methods. The best success has been found with an integrated pest management (IPM) strategy that incorporates one or several of these options along with education and prevention efforts (DiTomaso 2000).

State 5 Conifer Encroached State

The Conifer Encroached State may contain as many as four different communities defined by the amount of encroachment and age class of the stand. This state typically occurs in response to a combination of long-term fire suppression, grazing history, and increase atmospheric carbon dioxide. The trigger for transition is a coniferous expansion of greater than two stems per acre.

Community 5.1 Conifer Community

Rocky Mountain juniper (*Juniperus scopulorum*), ponderosa pine (*Pinus ponderosa*), and Douglas fir (*Pseudotsuga menziesii*) encroachment is common on this ecological site and is generally focused in areas where the mountains of MLRA 44B transition quickly to MLRA 43B. Under the Reference State, no conifers should exist on this site. It is also noted that all states may transition to the Conifer Encroached State; however, encroachment is most likely to occur in the Altered State, where there is an increase in bare ground due to a combination of factors that allows seed-to-soil contact with reduced competition. Fire suppression and improper grazing management are the two most common triggers. The exact mode in which conifers begin to encroach varies; however, the trend points to a combination of 1 or more of the following: repeated moderately heavy to heavy grazing; reduced (non-existent) fire frequency; increased atmospheric carbon; and a generally warmer climate compared to that of pre-settlement. When heavy grazing occurs, areas in the plant canopy open, allowing for seed dispersal by bird or overland flow via rills on neighboring sites. The effects of conifer encroachment are not immediately noticeable, but over time, as the conifer canopy increases, light and water interception increase, which reduces opportunities for herbaceous plants. One paper (Barrett, 2007) suggests that for precipitation to penetrate the juniper canopy, events must be greater than 0.30 inches. Increased tree canopy creates perching sites for predators, which reduces site suitability for

greater sage grouse. More information is needed on the full extent and impact of juniper encroachment on these plant communities for an approved ecological site description. Studies (Miller et al., 2000) based in an area similar to the Rocky Mountain juniper community of Montana suggest following a phased approach to characterizing the juniper stand. Not unlike the western juniper community discussed in Miller et al., the Conifer Encroached Communities of Montana exhibit three or four different phases based, at this time, on qualitative experience. Phase I (Early) is defined by actively expanding conifer cover with generally less than 10 percent canopy cover and the tree limbs generally touching the ground. This early stage generally has not completely lost its hydrologic functions, but herbaceous plant communities may show signs of reduced production and species richness. Control methods include mechanical removal and prescribed fire. Prescribed fire is still effective in this phase as it still contains the necessary native plants for recovery. The tree canopy is also low enough that the risk of a dangerously hot fire is reduced. Phase II (Midphase) is still actively expanding, but canopy cover may reach 15 to 25 percent, and due to the more mature trees, seed production is very high. This Midphase begins to highly restrict herbaceous and shrubby plants, and junipers tend to be codominant. Hydrology is departing from reference, with rills becoming longer and, in isolated areas, erosional gullies possible. Control methods for the Midphase should focus on mechanical treatment, as there is a high risk of catastrophic and potentially sterilizing fire. Phase III (Late Phase) is where conifer cover exceeds 25 percent and has slowed as a forest condition. Lower tree limbs begin to die, and the shrub cover is nearly gone. Traveling through this community is increasingly difficult. Conifers become the dominant plant, with herbaceous plant production greatly decreasing. Bare ground increases, and hydrologic function is nearly lost compared to a grass or shrub community. The late phase should focus more on restoration than control, as the necessary plants will likely not be present to cross the threshold back to a rangeland situation. Because soil stability and hydrologic function are lacking in this phase, mechanical juniper removal will be required. Phase IV (Closed Phase) is the steady state forest, where the system is nearly devoid of rangeland plants. The trees stop producing seed and begin to close in on each other. This phase is impassable, and nearly all light and precipitation are intercepted. Bare ground may be reduced due to excessive forest duff layer. As a result, soil chemistry slowly changes due to acidification from conifer needles. The closed phase is extremely rare in this LRU for two reasons. 1) This phase takes upwards of 100 years to occur and even under suppression, fire will control these sites 2) Management often occurs before trees are allowed to reach this phase. The presence of sagebrush stumps indicates that the historical plant community was rangeland, preventing the misclassification of historic coniferous forests (often more than 100 years old).

Transition T1A

State 1 to 2

The Bunchgrass State (1) transitions to the Altered State (2) if bluebunch wheatgrass, by dry weight, decreases to below 10 percent or if bare ground cover is increased beyond 20 percent. The driver for this transition is the loss of taller bunchgrasses, which creates open areas in the plant canopy with bare soil. Soil erosion reduces soil fertility, which drives transitions to the Altered State. There are several other key factors signaling the approach of transition T1A: increases in soil physical crusting, decreases in cover of cryptogamic crusts, decreases in soil surface aggregate stability, and/or evidence of erosion including water flow patterns, development of plant pedestals, and litter movement. The trigger for this transition is improper grazing management and/or long-term drought, leading to a decrease in bluebunch wheatgrass composition to less than 10 percent and a reduction in total plant canopy cover.

Transition T1C

State 1 to 3

The Bunchgrass State (1) transitions to the Degraded State (3) when bluebunch wheatgrass is removed from the plant community and needle and thread is subdominant to short-statured bunchgrasses such as Sandberg bluegrass. This transition differs from T1A in that it is usually quick and associated with disturbances like repeated overgrazing or heavy human traffic. This rapid transition is most commonly observed in situations where livestock are confined to small pastures for extended periods of time, such as horse pastures and calving lots. The driver for this transition is the loss of taller bunchgrasses, which creates openings in the canopy and exposes bare soil. Soil erosion reduces soil health, causing transitions to a degraded state. There are several other key factors signaling the approach of transition T1C: increases in soil physical crusting, decreases in cover of cryptogamic crusts, decreases in soil surface aggregate stability, and/or evidence of erosion including water flow patterns, development of plant pedestals, and litter movement. The trigger for this transition is improper grazing management, long term drought, and/or heavy human disturbance.

Transition T1B

State 1 to 4

Healthy plant communities are most resistant to invasion. However, regardless of grazing management, without some form of active weed management (chemical, mechanical, or biological control) and prevention, the Bunchgrass State (1) can transition to the Invaded State (4) in the presence of aggressive invasive species such as spotted knapweed, leafy spurge, and cheatgrass. This will occur even if the reference community is thriving. The Central Rocky Mountain Valleys tend to resist invasion by cheatgrass; however, repeated heavy grazing or intense human activities can open the interspaces of the bunchgrass community and allow for encroachment. Long-term stress conditions for native species (e.g., overgrazing, drought, and fire) accelerate this transition. If populations of invasive species reach critical levels, the site transitions to the Invaded State. The trigger for this transition is the presence of aggressive invasive species. The species composition by dry weight of invasive species approaches 10 percent.

Transition T1D

State 1 to 5

The transition from the Bunchgrass State (1) to the Conifer Encroached State (5) is driven primarily by long-term fire suppression but heavy grazing may contribute to increased bare ground for seeding sites. Encroachment often occurs fastest within 200 feet of the seed source. The trigger for transition is a conifer

Restoration pathway R2A

State 2 to 1

The Altered State (2) has lost soil or vegetation attributes to the point that recovery to the Bunchgrass State (1) will require reclamation efforts such as soil rebuilding, intensive mechanical and cultural treatments, and/or revegetation. Low intensity prescribed fires to reduce competitive increaser plants such as needle and thread and Sandberg bluegrass. A low-intensity fire will also reduce Wyoming big sagebrush densities. In areas with potential of annual grass infestation, fire should be carefully planned or avoided.

Transition T2A

State 2 to 3

As improper grazing management continues, the vigor of bunch grasses will decrease and the shorter grasses and shrubs will increase, contributing to the Degraded State (3). Prolonged drought will provide a competitive advantage to shrubs, allowing them to become co-dominant with grasses. The canopy cover of shrubs will increase above 15 percent. Key transition factors include: an increase in native shrub canopy cover; a reduction in bunchgrass production; a decrease in total plant canopy cover and production; increases in mean bare patch size; increases in soil crusting; decreases in the cover of cryptobiotic crusts; decreases in soil aggregate stability; and/or evidence of erosion, including water flow patterns and litter movement.

Transition T2B

State 2 to 4

Invasive species can occupy the Altered State (2) and drive it to the Invaded State (4). The Altered State is at risk if invasive seeds and/or other viable material are present. The driver for this transition is more than 10 percent of the dry weight of invasive species.

Transition T2C

State 2 to 5

The transition from the Altered State (2) to the Conifer Encroached State (5) is driven primarily by long-term fire suppression but long-term heavy grazing may contribute to increased bare ground for seeding sites. Encroachment often occurs fastest within 200 feet of the seed source. The trigger for transition is a conifer stem count higher than 2 stems per acre

Restoration pathway R3A

State 3 to 1

The Degraded State (3) has lost soil or vegetation attributes to the point that recovery to the Bunchgrass State (1) will require reclamation efforts, such as soil rebuilding, intensive mechanical treatments, and/or revegetation. Studies suggest (Whitford et al. 1989) that a mulch with a high carbon-to-nitrogen ratio, such as wood chips or bark, in low moisture scenarios can be beneficial for slow mobilization of plant-available nitrogen. Biochar may also be added to the system to improve Soil Organic Carbon (SOC) which should improve Cation Exchange Capacity (CEC), microbial activity, and hydrologic conductivity (Stavi 2012). The drivers for the restoration pathway are the removal of increaser species, restoration of native bunchgrass species, persistent management of invasives and shrubs, and proper grazing management. Without continued control, invasive and shrub species are likely to return (probably rapidly) due to the presence of seeds and/or other viable material in the soil and management-related increases in soil disturbance.

Restoration pathway R3B

State 3 to 2

Since the bunchgrass plant community has been significantly reduced, restoration to the Altered State (2) is unlikely unless a seed source is available. However, if a sufficient amount of grass remains on the site, chemical application and/or biological control, in conjunction with proper grazing management, can reduce the amount of shrubs and invasive species and restore the site to the shortgrass community (2.2). Low-intensity fire can be utilized to reduce Wyoming big sagebrush competition and allow the reestablishment of grass species. Caution must be used when considering fire as a management tool on sites with fire-tolerant shrubs such as rubber rabbitbrush, as these shrubs will sprout after a burn. Broom snakeweed and fringed sagewort may or may not re-sprout depending on conditions (USDA Forest Service, 2011).

Transition T3A

State 3 to 4

Invasive species can occupy the Degraded State (3) and drive it to the Invaded State (4). The Degraded State is at risk of this transition occurring if invasive seeds or viable material are present. The driver for this transition is the presence of critical population levels (more than 10 percent dry weight of invasive species). The trigger is the presence of seeds or viable material from invasive species. This state has sufficient bare ground that the transition could occur simply due to the presence or introduction of invasive seeds or viable material. This is particularly true of aggressive invasive species such as spotted knapweed. This transition could be assisted by overgrazing (failure to adjust stocking rate to declining forage production), a long-term lack of fire, or an extensive drought.

Transition T3B

State 3 to 5

The transition from the Degraded State (3) to the Conifer Encroached State (5) is driven primarily by long-term heavy grazing and increased bare ground for seeding sites. Encroachment often occurs fastest within 200 feet of the seed source. The trigger for transition is a conifer stem count higher than 2 per acre.

Restoration pathway R4B

State 4 to 2

If invasive species are removed before remnant populations of bunchgrass have been drastically reduced, the invaded state (4) can return to the Altered State. The driver for the reclamation pathway is weed management with reseeding. Continued Integrated Pest Management (IPM) will be required as many of the invasive species that can occupy the Invaded State have extended dormant seed life.

Transition T4A

State 4 to 5

The transition from the Invaded State (4) to the Conifer Encroached State (5) is driven primarily by long-term fire suppression but long-term heavy grazing may contribute to increased bare ground for seeding sites. Encroachment

often occurs fastest within 200 feet of the seed source. The trigger for transition is a conifer

Restoration pathway R5A

State 5 to 1

Restoration efforts may simply focus on the removal of coniferous trees and shrubs to restore the Conifer Encroached State (5) to the Reference State (1), depending on the level of conifer canopy cover and its impact on rangeland health. If following and utilizing the phases established by Miller et al., management and restoration methods will vary. A majority of the conifer encroachment in MLRA 44B will fall into the early two phases of Miller's phases. When conifers are removed through brush management and/or prescribed fire, Phase I may reveal none-to-slight to moderate deviations from rangeland health. If mechanical removal of conifers is utilized, no grazing management is needed, assuming relatively conservative management had been used prior to treatment. If prescribed fire is utilized, short-term grazing deferment and/or rest are suggested. In a short period of time, removing a Phase I encroachment will return the site to its original state. Proactive pest management is encouraged. Phase II encroachment may require a more intensive mechanical removal of trees and shrubs, with prescribed fire not being a feasible method of control as this community may be at risk of catastrophic fire due to canopy density. Phase II displays a moderate departure from Reference, suggesting an overall instability of the site such as reduced herbaceous production, reduced functional/structural groups (e.g., reduced mid-statured bunchgrasses), increased rill frequency and length, and possibly more bare ground. Increased post-treatment grazing management may be necessary. Grazing management may be as simple as short-term growing season deferment; however, long-term rest may be necessary in the latter stages of Phase II encroachment. The latter stages of Phase II encroachment will likely require some short-term erosion mitigation, such as straw wattles, as well as range planting and/or critical area planting to re-establish any loss of native herbaceous plants, particularly mid-statured cool-season bunchgrasses. Phase III encroachment canopy cover resembles forested sites with larger trees and shrubs. Prior to any prescribed burning, forest management-style tree removal (removal of woody debris and logs from the site) will be required to prevent the fire from burning too hot. The result of a prescribed fire on this site is typically unknown as seed sources of native herbaceous plants are usually limited to small patches. Since the Shallow Clay ecological site for 44B LRU 01 Subset A is a dry site, herbaceous plants will likely have been depleted under a Phase III encroachment. This means there is an opportunity for large areas of bare ground, increased rilling, and, in some cases, gully erosion. Post-treatment will require range planting and/or critical area seeding, erosion control, pest management, and possibly soil carbon amendments (biochar). Grazing management (primarily rest) will be required to ensure the establishment of any new seedlings.

Restoration pathway R5B

State 5 to 2

The Conifer Encroached State (5) Phases I and II will generally resemble the Altered State (2) on this site. If following and utilizing the phases established by Miller et al., management and restoration methods will vary. A majority of the conifer encroachment in MLRA 44B will fall into the early two phases of Miller's phases. When conifers are removed through brush management and/or prescribed fire, Phase I may show none-to-slight to moderate deviations from rangeland health. If mechanical removal of conifers is utilized, no grazing management is needed, assuming relatively conservative management had been used prior to treatment. If prescribed fire is utilized, short-term grazing deferment and/or rest are suggested. In a short period of time, removing a Phase I encroachment will return the site to its original state. Proactive pest management is encouraged. Phase II encroachment may require a more intensive mechanical removal of trees and shrubs, with prescribed fire not being a feasible method of control as this community may be at risk of catastrophic fire due to canopy density. Phase II displays a moderate departure from Reference, suggesting an overall instability of the site such as reduced herbaceous production, reduced functional and structural groups (e.g., reduced mid-statured bunchgrasses), increased rill frequency and length, and possibly more bare ground. Increased post-treatment grazing management may be necessary. Grazing management may be as simple as short-term growing season deferment; however, long-term rest may be necessary in the latter stages of Phase II encroachment. The latter stages of Phase II encroachment will likely require some short-term erosion mitigation such as straw wattles as well as range planting and/or critical area planting to re-establish any loss of native herbaceous plants, particularly mid-statured cool-season bunchgrasses. Phase III encroachment canopy cover resembles forested sites with larger trees and shrubs. Prior to any prescribed burning, forest management-style tree removal (removal of woody debris and logs from the site) will be required to prevent the fire from burning too hot. The result of a prescribed fire on this site is typically unknown as seed sources of native herbaceous plants are usually limited to small patches. Since the Shallow Clay ecological site for 44B LRU 01 Subset A is a dry site, herbaceous plants will likely have been depleted under a

Phase III encroachment. This means there is an opportunity for large areas of bare ground, increased rilling, and, in some cases, gully erosion. Post-treatment will require range planting and/or critical area seeding, erosion control, pest management, and possibly soil carbon amendments (biochar). Grazing management (primarily rest) will be required to ensure the establishment of any new seedlings.

Restoration pathway R5C State 5 to 3

The Conifer Encroached State (5) Phases II and III may resemble the Degraded State (3) on this site. If following and utilizing the phases established by Miller et al., management and restoration methods will vary. An overwhelming majority of the conifer encroachment in MLRA 44B will fall into the early two phases of Miller's phases. This restoration pathway is extremely rare because managing a degraded state is typically not cost-effective for land managers. When conifers are removed through brush management and/or prescribed fire, Phase I may show none-to-slight to moderate deviations from rangeland health. If mechanical removal of conifers is utilized, no grazing management is needed, assuming relatively conservative management had been used prior to treatment. If prescribed fire is utilized, short-term grazing deferment and/or rest are suggested. Given a short time removal of a Phase I encroachment will recover to Reference. Proactive pest management is encouraged. Phase II Encroachment may require a more intensive mechanical removal of trees and shrubs, with prescribed fire not being a feasible method of control as this community may be at risk of catastrophic fire due to canopy density. Phase II displays a moderate departure from Reference, suggesting an overall instability of the site such as reduced herbaceous production, reduced functional and structural groups (e.g., reduced mid-statured bunchgrasses), increased rill frequency and length, and possibly more bare ground. Increased post-treatment grazing management may be necessary. Grazing management may be as simple as short-term growing season deferment; however, long-term rest may be necessary in the latter stages of Phase II encroachment. The latter stages of Phase II encroachment will likely require some short-term erosion mitigation, such as straw wattles, as well as range planting and/or critical area planting to re-establish any loss of native herbaceous plants, particularly mid-statured cool-season bunchgrasses. Phase III Encroachment canopy cover resembles forested sites with larger trees and shrubs. Forest management style tree removal (woody debris and logs removed from the site) will be necessary prior to any prescribed burning as to prevent the fire from burning too hot. The results of a prescribed fire on this site are typically unknown as seed sources of native herbaceous plants are usually limited to small patches. Since the Shallow Clay ecological site for 44B LRU 01 Subset A is a dry site, herbaceous plants will likely have been depleted under a Phase III encroachment. This means there is an opportunity for large areas of bare ground, increased rilling, and, in some cases, gully erosion. Post-treatment will require range planting and/or critical area seeding, erosion control, pest management, and possibly soil carbon amendments (biochar). Grazing management (primarily rest) will be required to ensure the establishment of any new seedlings.

Additional community tables

Table 8. Community 1.1 plant community composition

Group	Common Name	Symbol	Scientific Name	Annual Production (Lb/Acre)	Foliar Cover (%)
Grass/Grasslike					
1	Mid-Statured Cool Season bunchgrass			450–600	
	bluebunch wheatgrass	PSSP6	<i>Pseudoroegneria spicata</i>	340–560	35–55
	green needlegrass	NAVI4	<i>Nassella viridula</i>	43–85	5–10
	needle and thread	HECO26	<i>Hesperostipa comata</i>	0–60	0–7
2	Rhizomatous grasses			200–250	
	western wheatgrass	PASM	<i>Pascopyrum smithii</i>	170–250	7–12
	thickspike wheatgrass	ELLA3	<i>Elymus lanceolatus</i>	0–50	0–3
3	Shortgrasses/Grasslikes			20–40	
	blue grama	BOGR2	<i>Bouteloua gracilis</i>	10–42	1–5
	prairie Junegrass	KOMA	<i>Koeleria macrantha</i>	15–25	1–3
	Sandberg bluegrass	POSE	<i>Poa secunda</i>	15–25	1–3
	plains reedgrass	CAMO	<i>Calamagrostis montanensis</i>	0–25	0–3

	threadleaf sedge	CAFI	<i>Carex filifolia</i>	0–15	0–1
Forb					
4	Forbs			30–45	
	dotted blazing star	LIPU	<i>Liatris punctata</i>	10–50	0–4
	American vetch	VIAM	<i>Vicia americana</i>	10–50	0–4
	purple prairie clover	DAPU5	<i>Dalea purpurea</i>	0–30	0–2
	scarlet globemallow	SPCO	<i>Sphaeralcea coccinea</i>	0–25	0–1
	hairy false goldenaster	HEVI4	<i>Heterotheca villosa</i>	0–20	0–1
	spiny phlox	PHHO	<i>Phlox hoodii</i>	0–10	0–1
	bastard toadflax	COUM	<i>Comandra umbellata</i>	0–10	0–1
	desertparsley	LOMAT	<i>Lomatium</i>	0–10	0–1
	common yarrow	ACMI2	<i>Achillea millefolium</i>	0–10	0–1
	locoweed	OXYTR	<i>Oxytropis</i>	0–5	0–1
Shrub/Vine					
5	Shrubs			75–90	
	Wyoming big sagebrush	ARTRW8	<i>Artemisia tridentata ssp. wyomingensis</i>	42–100	0–15
	yellow rabbitbrush	CHVI8	<i>Chrysothamnus viscidiflorus</i>	0–60	0–3
	winterfat	KRLA2	<i>Krascheninnikovia lanata</i>	15–50	1–3
	broom snakeweed	GUSA2	<i>Gutierrezia sarothrae</i>	0–15	0–1
	prairie sagewort	ARFR4	<i>Artemisia frigida</i>	0–10	0–2
	plains pricklypear	OPPO	<i>Opuntia polyacantha</i>	0–10	0–1
	spineless horsebrush	TECA2	<i>Tetradymia canescens</i>	0–10	0–1
	currant	RIBES	<i>Ribes</i>	0–5	0–1
	Woods' rose	ROWO	<i>Rosa woodsii</i>	0–5	0–1
Tree					
6	Coniferous Trees and Tall Shrubs			0–10	
	Rocky Mountain juniper	JUSC2	<i>Juniperus scopulorum</i>	0–10	0–1
	ponderosa pine	PIPOS	<i>Pinus ponderosa var. scopulorum</i>	0–10	0–1
	Douglas-fir	PSME	<i>Pseudotsuga menziesii</i>	0–10	0–1

Animal community

The Shallow Clay (SwC) ecological site provides a variety of wildlife habitats for an array of species. Prior to the settlement of this area, large herds of antelope, elk, and bison roamed. Though the bison have been replaced, mostly with domesticated livestock, elk and antelope still frequently utilize this largely intact landscape for winter habitat in areas adjacent to forests.

The relatively high grass component of the Reference Community provides excellent nesting cover for multiple neotropical migratory birds that select for open grasslands, such as the long-billed curlew and McCown's longspur.

Managed livestock grazing is suitable on this site due to the potential to produce an abundance of high-quality forage. This is often a preferred site for grazing by livestock, and animals tend to congregate in these areas. To maintain the productivity of the Shallow Clay site, grazing on adjoining sites with less production must be managed carefully to be sure utilization on this site is not excessive. Management objectives should include maintenance or improvement of the native plant community. Careful management of the timing and duration of grazing is important. Shorter grazing periods and adequate deferment during the growing season are recommended for plant

maintenance, health, and recovery. According to McLean et al., early-season defoliation of bluebunch wheatgrass can result in high mortality and reduced vigor in plants. They also suggest, based on prior studies, that the opportunity for regrowth is necessary before dormancy to reduce injury bluebunch.

Since needle-and-thread normally matures earlier than bluebunch wheatgrass and produces a sharp awn, this species is usually avoided after seed set. Changing the grazing season will help utilize needle and thread more efficiently.

Continual non-prescribed grazing of this site will be injurious, will alter the plant composition and production over time, and will result in the transition to the Altered State. The transition to other states will depend on the duration of poorly managed grazing as well as other circumstances such as weather conditions and fire frequency.

The Altered State can degrade further to the Degraded Shortgrass State or the Invaded State. Management should focus on grazing management strategies that will prevent further degradation, such as seasonal grazing deferment or winter grazing where feasible. Communities within this state are still stable and healthy under proper management. Forage quantity and quality may be substantially decreased from the Reference State.

Grazing is possible in the Invaded State. Invasive species are generally less palatable than native grasses. Forage production is typically greatly reduced in this state. Due to the aggressive nature of invasive species, sites in the Invaded State face an increased risk of further degradation to the Invaded Communities. Grazing must be carefully managed to avoid further soil loss and degradation and possible livestock health issues.

Prescriptive grazing can be used to manage invasive species. In some instances, carefully targeted grazing (sometimes in combination with other treatments) can reduce or maintain species composition of invasive species. In the Degraded Shortgrass State, grazing may be possible but is generally not economically and/or environmentally sustainable.

Hydrological functions

The hydrologic cycle functions best in the Bunchgrass State (1) with good infiltration and deep percolation of rainfall; however, the cycle degrades as the vegetation community declines. Rapid rainfall infiltration, high soil organic matter, good soil structure, and good porosity accompany high bunchgrass canopy cover. High ground cover reduces raindrop impact on the soil surface, which keeps erosion and sedimentation transport low. Water leaving the site will have a minimal sediment load, which allows for high water quality in associated streams. High rates of infiltration will allow water to move below the rooting zone during periods of heavy rainfall. The Bluebunch Wheatgrass Community (1.1) should have no rills or gullies present, and drainage ways should be vegetated and stable. Water flow patterns, if present, will be barely observable. Plant pedestals are essentially nonexistent. Plant litter remains in place and is not moved by wind or water.

Improper grazing management results in a community shift to the Mixed Bunchgrass Community (1.2). This plant community has a similar canopy cover, but bare ground will have less than 15 percent canopy. Therefore, the hydrologic cycle is functioning at a level similar to the water cycle in the Bluebunch Wheatgrass Community/Needle-and-Thread (1.1). Compared to the Bluebunch Wheatgrass/Needle-and-Thread Community (1.1), infiltration rates are slightly reduced and surface runoff is slightly higher.

In the Rhizomatous Community (2.1), the Degraded Shortgrass State (3) and the Invaded State (4) have greatly reduced canopy and ground cover compared to the Bunchgrass State (1), which impedes the hydrologic cycle. Infiltration will decrease and runoff will increase due to reduced ground cover, the presence of shallow-rooted species, rainfall splash, soil capping, reduced organic matter, and poor structure. Sparse ground cover and decreased infiltration can combine to increase the frequency and severity of flooding within a watershed. Soil erosion is accelerated, the quality of surface runoff is poor, and sedimentation increases.

The hydrology of the Conifer Encroached State (5) is highly variable, but studies suggest that an increased tree canopy affects the interception of rainfall as well as the amount of available soil moisture for herbaceous vegetation. This can negatively affect infiltration and increase runoff.

Recreational uses

This site provides some limited recreational opportunities for hiking, horseback riding, big game hunting, and upland bird hunting. The forbs have flowers that appeal to photographers. This site provides valuable open space.

Inventory data references

Information presented was derived from the site's Range Site Description (SwCy 9 –14" P.Z., Northern Rocky Mountain Valleys, South, East of Continental Divide), NRCS clipping data, literature, field observations, and personal contacts with range-trained personnel (i.e., used professional opinion of agency specialists, observations of land managers, and outside scientists).

References

. Fire Effects Information System. <http://www.fs.fed.us/database/feis/>.

. 2021 (Date accessed). USDA PLANTS Database. <http://plants.usda.gov>.

Arno, S.F. and G.E. Gruell. 1982. Fire History at the Forest-Grassland Ecotone in Southwestern Montana. *Journal of Range Management* 36:332–336.

Barrett, H. 2007. *Western Juniper Management: A Field Guide*.

Bestelmeyer, B., J.R. Brown, J.E. Herrick, D.A. Trujillo, and K.M. Havstad. 2004. Land Management in the American Southwest: a state-and-transition approach to ecosystem complexity. *Environmental Management* 34:38–51.

Bestelmeyer, B. and J. Brown. 2005. State-and-Transition Models 101: A Fresh look at vegetation change.

Blaisdell, J.P. 1958. Seasonal development and yield of native plants on the Upper Snake River Plains and their relation to certain climate factors.

Blaisdell, J.P. and R.C. Holmgren. 1984. Managing Intermountain Rangelands--Salt-Desert Shrub Ranges. General Tech Report INT-163. USDA Forest Service, Intermountain Forest and Range Experiment Station, Ogden, UT. 52.

Bunting, S.C., B.M. Kilgore, and C.L. Bushey. 1987. Guidelines for Prescribe burning sagebrush-grass rangelands in the Northern Great Basin. General Technical Report INT-231. USDA Forest Service Intermountain Research Station, Ogden, UT. 33.

Colberg, T.J. and J.T. Romo. 2003. Clubmoss effects on plant water status and standing crop. *Journal of Range Management* 56:489–495.

Daubenmire, R. 1970. *Steppe vegetation of Washington*.

DiTomaso, J.M. 2000. Invasive weeds in Rangelands: Species, Impacts, and Management. *Weed Science* 48:255–265.

Dormaar, J.F., B.W. Adams, and W.D. Willms. 1997. Impacts of rotational grazing on mixed prairie soils and

- vegetation. *Journal of Range Management* 50:647–651.
- Hobbs, J.R. and S.E. Humphries. 1995. An integrated approach to the ecology and management of plant invasions. *Conservation Biology* 9:761–770.
- Kuchler, A.W. 1964. Potential natural vegetation of the conterminous United States.
- Lacey, J.R., C.B. Marlow, and J.R. Lane. 1989. Influence of Spotted knapweed (*Centaurea maculosa*) on surface runoff and sediment yield.. *Weed Technology* 3:627–630.
- Lesica, P. and S.V. Cooper. 1997. Presettlement vegetation of Southern Beaverhead County, MT.
- Manske, L.L. 1980. Habitat, phenology, and growth of selected sandhills range plants.
- Masters, R. and R. Sheley. 2001. Principles and practices for managing rangeland invasive plants. *Journal of Range Management* 38:21–26.
- McCalla, G.R., W.H. Blackburn, and L.B. Merrill. 1984. Effects of Livestock Grazing on Infiltration Rates of the Edwards Plateau of Texas. *Journal of Range Management* 37:265–269.
- McLean, A. and S. Wikeem. 1985. Influence of season and intensity of defoliation on bluebunch wheatgrass survival and vigor in southern British Columbia. *Journal of Range Management* 38:21–26.
- Miller, R.F., T.J. Svejcar, and J.A. Rose. 2000. Impacts of western juniper on plant community composition and structure. *Journal of Range Management* 53:574–585.
- Moulton, G.E. and T.W. Dunlay. 1988. *The Journals of the Lewis and Clark Expedition*. Pages in University of Nebraska Press.
- Mueggler, W.F. and W.L. Stewart. 1980. Grassland and Shrubland Habitat Types of Western Montana.
- Pelant, M., P. Shaver, D.A. Pyke, and J.E. Herrick. 2005. Interpreting Indicators of Rangeland Health.
- Pellant, M. and L. Reichert. 1984. Management and Rehabilitation of a burned winterfat community in Southwestern Idaho. Proceedings--Symposium on the biology of Atriplex and related Chenopods. 1983 May 2-6; Provo UT General Technical Report INT-172.. USDA Forest Service Intermountain Forest and Range Experiment Station. 281–285.
- Pitt, M.D. and B.M. Wikeem. 1990. Phenological patterns and adaptations in an *Artemisia/Agropyron* plant community. *Journal of Range Management* 43:350–357.
- Pokorny, M.L., R. Sheley, C.A. Zabinski, R. Engel, T.J. Svejcar, and J.J. Borkowski. 2005. Plant Functional Group Diversity as a Mechanism for Invasion Resistance.
- Ross, R.L., E.P. Murray, and J.G. Haigh. July 1973. Soil and Vegetation of Near-pristine sites in Montana.

- Schoeneberger, P.J. and D.A. Wysocki. 2017. Geomorphic Description System, Version 5.0..
- Smoliak, S., R.L. Ditterlin, J.D. Scheetz, L.K. Holzworth, J.R. Sims, L.E. Wiesner, D.E. Baldrige, and G.L. Tibke. 2006. Montana Interagency Plant Materials Handbook.
- Stavi, I. 2012. The potential use of biochar in reclaiming degraded rangelands. *Journal of Environmental Planning and Management* 55:1–9.
- Stringham, T.K., W.C. Kreuger, and P.L. Shaver. 2003. State and Transition Modeling: an ecological process approach. *Journal of Range Management* 56:106–113.
- Stringham, T.K. and W.C. Krueger. 2001. States, Transitions, and Thresholds: Further refinement fro rangeland applications.
- Sturm, J.J. 1954. A study of a relict area in Northern Montana. University of Wyoming, Laramie 37.
- Thurow, T.L., Blackburn W. H., and L.B. Merrill. 1986. Impacts of Livestock Grazing Systems on Watershed. Page in *Rangelands: A Resource Under Siege: Proceedings of the Second International Rangeland Congress*.
- Various NRCS Staff. 2013. National Range and Pasture Handbook.
- Walker, L.R. and S.D. Smith. 1997. Impacts of invasive plants on community and ecosystem properties. Pages 69–86 in *Assessment and management of plant invasions*. Springer, New York, NY.
- Wambolt, C. and G. Payne. 1986. An 18-Year Comparison of Control Methods for Wyoming Big Sagebrush in Southwestern Montana. *Journal of Range Management* 39:314–319.
- West, N.E. 1994. Effects of Fire on Salt-Desert shrub rangelands. *Proceedings--Ecology and Management of Annual Rangelands: 1992 May 18-22*. Boise ID General Technical Report INT-GTR-313.. USDA Forest Service Intermountain Research Station. 71–74.
- Whitford, W.G., E.F. Aldon, D.W. Freckman, Y. Steinberger, and L.W. Parker. 1989. Effects of Organic Amendments on Soil Biota on a Degraded Rangeland. *Journal of Range Management* 41:56–60.
- Wilson, A.M., G.A. Harris, and D.H. Gates. 1966. Cumulative Effects of Clipping on Yield of Bluebunch wheatgrass. *Journal of Range Management* 19:90–91.

Approval

Kirt Walstad, 9/08/2023

Rangeland health reference sheet

Interpreting Indicators of Rangeland Health is a qualitative assessment protocol used to determine ecosystem condition based on benchmark characteristics described in the Reference Sheet. A suite of 17 (or more) indicators are typically considered in an assessment. The ecological site(s) representative of an assessment location must be known prior to applying the protocol and must be verified based on soils and climate. Current plant community

cannot be used to identify the ecological site.

Author(s)/participant(s)	Grant Petersen
Contact for lead author	grant.petersen@usda.gov
Date	04/25/2019
Approved by	Kirt Walstad
Approval date	
Composition (Indicators 10 and 12) based on	Annual Production

Indicators

- 1. Number and extent of rills:** Rills will not be evident on lesser sloping Reference Communities. Steeper slopes (greater than 30%) may have rills particularly after extreme weather events however they will remain short

- 2. Presence of water flow patterns:** Water flow patterns will not be evident on lesser sloping Reference Communities however will likely be evident on slopes greater than 30% however they will be short.

- 3. Number and height of erosional pedestals or terracettes:** Steep slopes (greater than 30%) may contain both pedestals and terracettes as a result of slow infiltration and higher run-off. Height of either will not exceed $\frac{3}{4}$ " tall.

- 4. Bare ground from Ecological Site Description or other studies (rock, litter, lichen, moss, plant canopy are not bare ground):** Bare ground in Reference State can be highly variable from 20-30%.

- 5. Number of gullies and erosion associated with gullies:** Not present.

- 6. Extent of wind scoured, blowouts and/or depositional areas:** Not Evident

- 7. Amount of litter movement (describe size and distance expected to travel):** Litter movement varies by slope class of the site as well as size of litter. In Reference, litter typically consists of perennial grass leaves and stems up less than 6-8 inches long and 0.25 inches in diameter. These types of litter tend to be resistant to movement on gentle slopes however may move up to 12 inches on steeper slopes as a result of extreme weather events.

- 8. Soil surface (top few mm) resistance to erosion (stability values are averages - most sites will show a range of values):** Site tends to remain relatively stable due to clay content. Stability values of 4-6 in interspaces and 5-6 under plant canopies/bases. A horizon is less than 2 inches thick

- 9. Soil surface structure and SOM content (include type of structure and A-horizon color and thickness):** Structure is medium to strong fine granular. A Horizon should be 2 inches thick with color, when wet, typically ranging in Value of 5 or less and Chroma of 3 or less. Local geology may affect color in which it is important to reference the Official Series

10. **Effect of community phase composition (relative proportion of different functional groups) and spatial distribution on infiltration and runoff:** Infiltration is naturally slow to clay content of soil. High proportions of deep rooted bunchgrasses combined with rhizomatous species between bunchgrasses optimized infiltration. Taproots of shrubs and forbs assist with infiltration. Plant spaces in a heterogenous pattern reduce runoff.
-
11. **Presence and thickness of compaction layer (usually none; describe soil profile features which may be mistaken for compaction on this site):** A compaction layer is not present in the reference condition.
-
12. **Functional/Structural Groups (list in order of descending dominance by above-ground annual-production or live foliar cover using symbols: >>, >, = to indicate much greater than, greater than, and equal to):**
- Dominant: Mid-statured, perennial bunchgrasses
- Sub-dominant: Rhizomatous grasses = shortgrasses/grasslikes > forbs ≥ shrubs ≥ subshrubs
- Other:
- Additional:
-
13. **Amount of plant mortality and decadence (include which functional groups are expected to show mortality or decadence):** Plant mortality and decadence is rare on grasses and forbs. Some shrubs may express decadence in response to high snow load with slow infiltration on occasion.
-
14. **Average percent litter cover (%) and depth (in):** Total litter cover ranges from 35 to 45%. Most litter is irregularly distributed on the soil surface and is not at a measurable depth.
-
15. **Expected annual annual-production (this is TOTAL above-ground annual-production, not just forage annual-production):** Average annual production is 850. Low: 580 High 1030. Production varies based on effective precipitation and natural variability of soil properties for this ecological site.
-
16. **Potential invasive (including noxious) species (native and non-native). List species which BOTH characterize degraded states and have the potential to become a dominant or co-dominant species on the ecological site if their future establishment and growth is not actively controlled by management interventions. Species that become dominant for only one to several years (e.g., short-term response to drought or wildfire) are not invasive plants. Note that unlike other indicators, we are describing what is NOT expected in the reference state for the ecological site:** Potential invasive (including noxious) species (native and non-native). Invasive species on this ecological site include (but not limited to) annual brome spp., spotted knapweed, yellow toadflax, ventenata, crested wheatgrass, etc.
- Native species such as rocky mtn Juniper, ponderosa pine, Douglas fir, broom snakeweed, rabbitbrush spp., big sagebrush, blue grama, etc. when their populations are significant enough to affect ecological function, indicate site

condition departure.

17. **Perennial plant reproductive capability:** In the reference condition, all plants are vigorous enough for reproduction either by seed or rhizomes in order to balance natural mortality with species recruitment.
-