

## Ecological site EX044B01B138 Shallow Droughty (SwDr) LRU 01 Subset B

Last updated: 9/11/2023  
Accessed: 05/18/2024

---

### General information

**Provisional.** A provisional ecological site description has undergone quality control and quality assurance review. It contains a working state and transition model and enough information to identify the ecological site.

### MLRA notes

Major Land Resource Area (MLRA): 044B—Central Rocky Mountain Valleys

Major Land Resource Area (MLRA) 44B, Central Rocky Mountain Valleys, is nearly 3.7 million acres of southwest Montana. This MLRA borders two other MLRAs: 43B, Central Rocky Mountains and Foothills, and 46, Northern and Central Rocky Mountain Foothills.

The major watersheds of this MLRA are the Missouri and Yellowstone Rivers and their associated headwaters, such as the Beaverhead, Big Hole, Jefferson, Ruby, Madison, Gallatin, and Shields Rivers. Limited portions of the MLRA are west of the Continental Divide along the Clark Fork River. These waters allow for extensive irrigation for crop production in an area that is generally only compatible with rangeland and grazing. The Missouri River and its headwaters are behind several reservoirs used for irrigation water, hydroelectric power, and municipal water.

The primary land use of this MLRA is production agriculture (grazing, small grain production, and hay) with limited mining. Urban development is high, with large expanses of rangeland being converted to subdivisions for a rapidly growing population.

MLRA 44B consists of one Land Resource Unit (LRU) and seven Climate-based LRU subsets. Annual precipitation ranges from a low of 9 inches to a high of near 24 inches. The driest areas tend to be in the valley bottoms of southwest Montana, in the rain shadow of the mountains. The wettest portions tend to be near the edges of the MLRA, where it borders MLRA 43B. Frost-free periods also vary greatly, with less than 30 days in the Big Hole Valley to approximately 110 days in the warm valleys along the Yellowstone and Missouri Rivers.

MLRA 44B's plant communities are highly variable but are dominated by a cool-season grass and shrub-steppe community on the rangeland and a mixed coniferous forest in the mountains. Warm-season grasses occupy an extremely limited extent and number of species in this MLRA. Most subspecies of big sagebrush are present, to some extent, across the MLRA.

### LRU notes

LRU 01 Climatic Subset B Central Concept:

- Moisture Regime: Ustic
- Temperature Regime: Frigid
- Dominant Cover: rangeland (mixed grassland and sagebrush steppe)
- Representative Value (RV) of range of Effective Precipitation: 15-19 inches
- Representative Value (RV) of range of Frost Free Days: 90-110 days

The Subset B is primarily located in Madison, Gallatin, Park, and Meagher Counties of Southwest Montana.

### Classification relationships

Mueggler and Stewart. 1980. Grassland and Shrubland habitat types of Western Montana

1. *Stipa comata/Bouteloua gracilis* h.t.

## 2. *Agropyron spicatum/Bouteloua gracilis* h.t.

Montana Natural Heritage Program Vegetation Classification

1. *Stipa comata* - *Bouteloua gracilis* Herbaceous Vegetation

(STICOM – BOUGRA) Needle-and-thread/Blue grama

Natural Heritage Conservation Rank-G5 / S5

Edition / Author- 99-11-16 / S.V. Cooper,

EPA Ecoregions of Montana, Second Edition:

Level I: Northwestern Forested Mountains

Level II: Western Cordillera

Level III: Middle Rockies & Northern Great Plains

Level IV: Paradise Valley

Townsend Basin

Dry Intermontane Sagebrush Valleys

Level I: Great Plains

Level II: West-Central Semi-Arid Prairies

Level III: Northwestern Great Plains

Level IV: Shield-Smith Valleys

Non-calcareous Foothill Grassland

### Ecological site concept

Site does not receive any additional water

- Soils are
  - o Not saline or saline-sodic
  - o Shallow (10-20 inches deep to bedrock, lithic, or paralithic root restrictive layer)
  - o Not strongly or violently effervescent (calcareous) in the surface mineral 4 inches
  - o Skeletal within 10-20 inches of soil surface (averages greater than 35 percent rock fragments in the 10-20 inch layer)
  - o Clay content less 32 percent in surface mineral 4 inches
- Parent material is colluvium and residuum from mixed geology

### Associated sites

EX044B01B136	<b>Shallow Loamy (SwLo) LRU 01 Subset B</b> The Shallow Loamy ecological site is often a neighboring site, sharing similar landscape position
--------------	--

### Similar sites

EX044B01B136	<b>Shallow Loamy (SwLo) LRU 01 Subset B</b> The Shallow Loamy ecological site shares plant community and state and transition model. The Shallow Loamy site does not have 35 percent rock fragments in the 10-20 inch zone resulting in higher water holding capacity and generally higher annual production.
--------------	--

Table 1. Dominant plant species

Tree	Not specified
Shrub	(1) <i>Artemisia tridentata</i> ssp. <i>wyomingensis</i> (2) <i>Rhus aromatica</i>
Herbaceous	(1) <i>Festuca campestris</i> (2) <i>Pseudoroegneria spicata</i>

### Legacy ID

R044BB138MT

## Physiographic features

This ecological site can be found on nearly flat to steep hillslopes and escarpments. It often occurs in complexes with other ecological sites. This site occurs from 2 to 45 percent; however, the core concept exists between 8 and 25 percent. Variations in plant community composition and production can result due to aspect, with south and west exposures tending to produce less. The amount of exposed rock outcrop tends to increase as slopes increase. Runoff and the potential for water erosion can be important features of this site.

**Table 2. Representative physiographic features**

Hillslope profile	(1) Summit (2) Shoulder
Landforms	(1) Intermontane basin > Scarp (2) Intermontane basin > Hillslope (3) Intermontane basin > Knoll
Runoff class	Medium to high
Elevation	1,463–1,981 m
Slope	8–25%

## Climatic features

The Central Rocky Mountain Valleys MLRA has a continental climate. Fifty to sixty percent of the annual long-term average total precipitation falls between May and August. Most of the precipitation in the winter is snow on frozen ground. Average precipitation for LRU 01 Subset B is 17 inches, and the frost-free period averages 95 days. Precipitation is highest in May and June.

See the climatic data sheet for more details (Section II of the Field Office Technical Guide:

<https://efotg.sc.egov.usda.gov/#/state/MT/documents/section=1&folder=8306>) or refer to the following climatic web site: <http://www.wrcc.dri.edu/climsum.html>.

**Table 3. Representative climatic features**

Frost-free period (characteristic range)	90-110 days
Freeze-free period (characteristic range)	96-123 days
Precipitation total (characteristic range)	356-483 mm
Frost-free period (actual range)	90-110 days
Freeze-free period (actual range)	82-136 days
Precipitation total (actual range)	356-483 mm
Frost-free period (average)	95 days
Freeze-free period (average)	108 days
Precipitation total (average)	432 mm

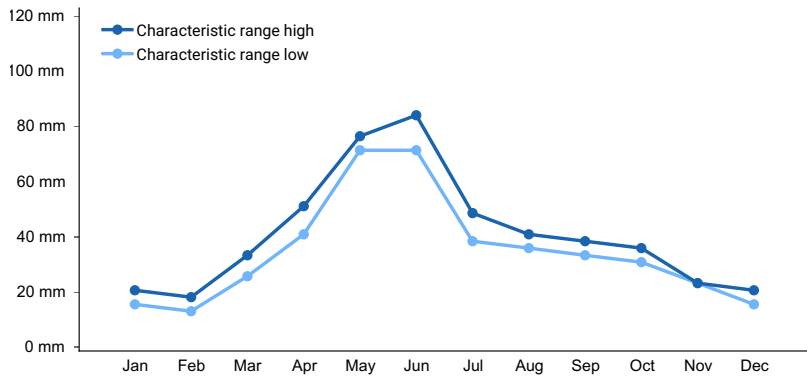

**Figure 1. Monthly precipitation range**

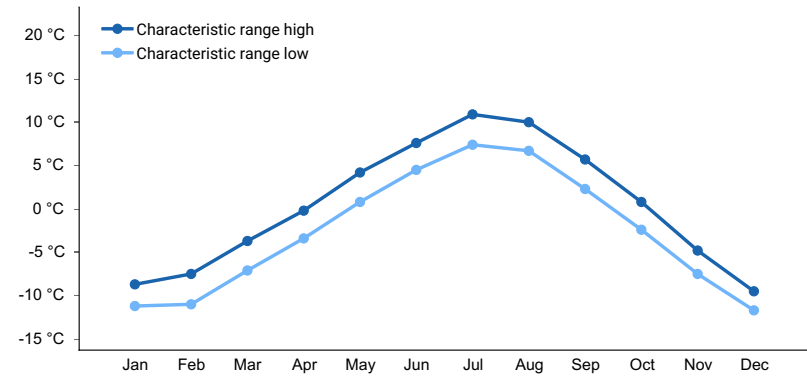

**Figure 2. Monthly minimum temperature range**

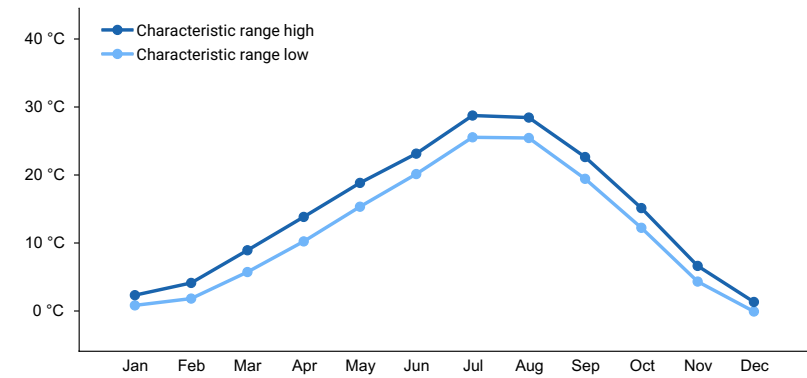

**Figure 3. Monthly maximum temperature range**

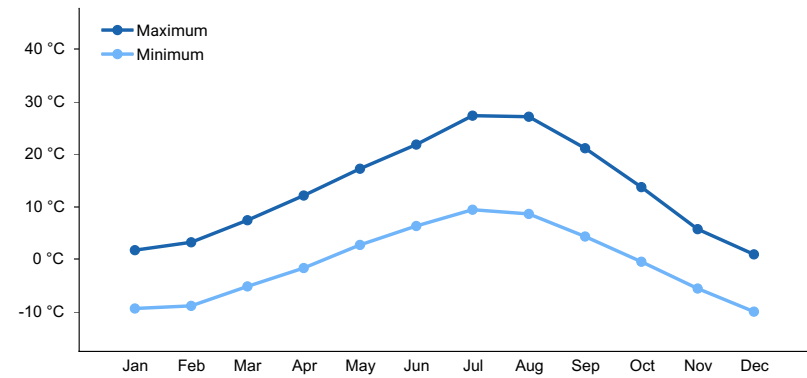

**Figure 4. Monthly average minimum and maximum temperature**

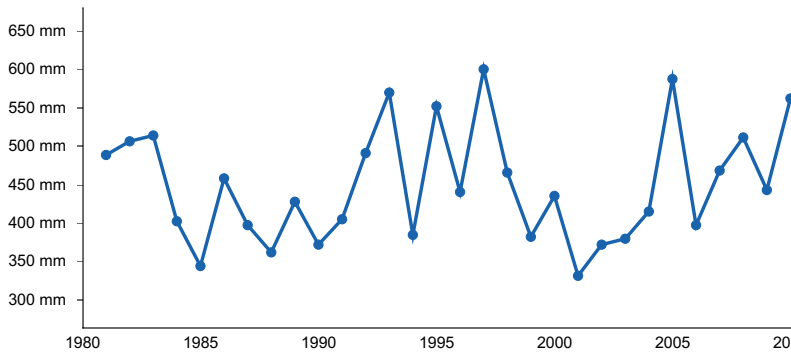

Figure 5. Annual precipitation pattern

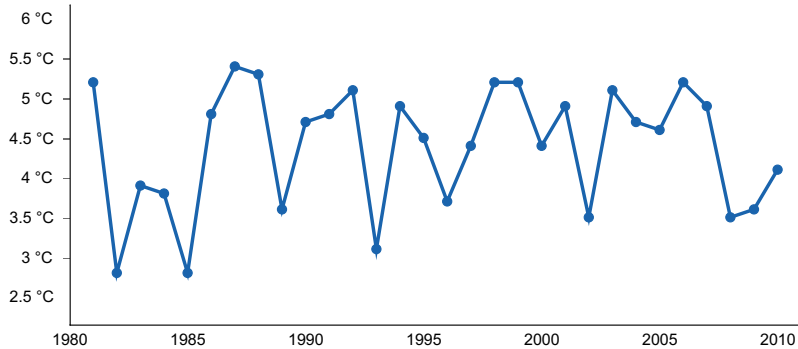

Figure 6. Annual average temperature pattern

### Climate stations used

- (1) WILSALL 8 ENE [USC00249023], Wilsall, MT
- (2) BOZEMAN 6 W EXP FARM [USC00241047], Bozeman, MT
- (3) NORRIS MADISON PH [USC00246157], Ennis, MT
- (4) MILLEGAN 14 SE [USC00245712], White Sulphur Springs, MT
- (5) LENNEP 5 SW [USC00244954], White Sulphur Springs, MT

### Influencing water features

This ecological site is not associated with water features. The Shallow Droughty ecological site is an upland site that is well drained.

### Wetland description

Site is not associated with wetlands

### Soil features

These soils are shallow to root-restricting bedrock. This site has moderate-to-moderately rapid permeability and is well drained. These soils formed from residuum of mixed origins, primarily from non-calcareous geology. Typically, soil surface textures consist of loam, clay loam, and silt loam textures. Soils have a gravelly surface that varies depending on its association with neighboring sites. The common soil series in this ecological site includes Castner and Tolbert. These soils may exist across multiple ecological sites due to natural variations in slope, texture, rock fragments, and pH.

Table 4. Representative soil features

Parent material	(1) Residuum—igneous, metamorphic and sedimentary rock
Surface texture	(1) Loam (2) Clay loam

Drainage class	Well drained to somewhat excessively drained
Permeability class	Moderate to moderately rapid
Depth to restrictive layer	25–51 cm
Soil depth	25–51 cm
Surface fragment cover ≤3"	0–15%
Surface fragment cover >3"	0–5%
Available water capacity (0-50.8cm)	3.81–6.35 cm
Soil reaction (1:1 water) (0-50.8cm)	7.6–8.2
Subsurface fragment volume ≤3" (25.4-50.8cm)	0–35%
Subsurface fragment volume >3" (25.4-50.8cm)	0–15%

## Ecological dynamics

The reference plant community is dominated by rough fescue (*Festuca campestris*), bluebunch wheatgrass (*Pseudoroegneria spicata*), and green needlegrass (*Nassella viridula*). Subdominant species may include western wheatgrass (*Pascoyprum smithii*), Idaho fescue (*Festuca idahoensis*), needle and thread (*Hesperostipa comata*), Wyoming big sage (*Artemisia tridentata* ssp. *wyomingensis*), sumac (*Rhus* spp.), snowberry (*Symphoricarpos albus*), winterfat (*Krascheninnikovia lanata*), and Indian ricegrass (*Achnatherum hymenoides*).

Natural fire was a major ecological driver of this entire ecological site. Fire tended to restrict tree and sagebrush growth to small patches and promote an herbaceous plant community. The natural fire return interval was highly variable, ranging up to 100 years; however, it was likely shorter than 35 years (Arno and Gruell 1983). With the historically recent, since 1910, suppression of fire sagebrush and trees has increased significantly.

Wyoming big sagebrush steppe communities historically had low fuel loadings and were characterized by 10- to 70-year interval fires that produced a mosaic of burned and unburned lands (Bunting et al., 1987). A shift to the dominance of shrubs may occur in response to improper grazing management, drought, or where big sagebrush occurs due to a lack of fire. Shrub encroachment by a variety of species, including, broom snakeweed (*Gutierrezia sarothrae*), fringed sagewort (*Artemisia frigida*), Wyoming big sagebrush, rubber rabbitbrush (*Ericameria nauseosa*), green rabbitbrush (*Chrysothamnus viscidiflorus*) and plains prickly pear cactus (*Opuntia polyacantha*) occur within this site as the mid-statured bunchgrasses decrease. Shrub dominance and grass loss can be associated with soil erosion and, ultimately, thinning of the native soil surface. Subsequent loss of soil could lead to a Degraded State. All states could also lead to the Invaded State when there is a lack of weed prevention and control measures.

Historical records indicate that, prior to the introduction of livestock (cattle and sheep) during the late 1800s, elk and bison grazed this ecological site. Due to the nomadic nature and herd structure of bison, areas that were grazed received periodic, high-intensity, short-duration grazing pressure. Livestock grazing has occurred on most of this ecological site in southwestern Montana for more than 150 years. The gold boom in the 1860s brought the first herds of livestock overland from Texas, and homesteaders began settling the area. During this time, cattle were the primary domestic grazers in the area. In the 1890s, Montana sheep production began to increase and dominated the livestock industry until the 1930s. Since the 1930s, cattle production has dominated the livestock industry in the region (Wyckoff and Hansen 2001).

Some of the major invasive species that can occur on this site include (but are not limited to) spotted knapweed (*Centaurea stoebe*), leafy spurge (*Euphorbia esula*), cheatgrass (*Bromus tectorum*), field brome (*Bromus arevensis*), yellow toadflax (*Linaria vulgaris*), and dandelion (*Taraxicum* spp.). Invasive weeds are beginning to have a high impact on this ecological site, particularly cheatgrass invasion.

## Plant Communities and Transitions

A state and transition model for this ecological site is depicted below. Thorough descriptions of each state, transition, plant community, and pathway follow the model. This model is based on available experimental research, field data, field observations, and interpretations by experts. It is likely to change as knowledge increases.

The plant communities within the same ecological site will differ across the MLRA due to the naturally occurring variability in weather, soils, and aspect. The biological processes on this site are complex; therefore, representative values are presented in a land management context. The species lists are representative and are not botanical descriptions of all species occurring, or potentially occurring, on this site. They are intended to cover the core species and the known range of conditions and responses.

Although there is considerable qualitative experience supporting the pathways and transitions within the STM, no quantitative information exists that specifically identifies threshold parameters between grassland types and invaded types in this ecological site. For information on STMs, see the following citations: Bestelmeyer et al. (2003), Bestelmeyer et al. (2004), Bestelmeyer and Brown (2005), and Stringham et al. (2003).

## State and transition model

### Ecosystem states

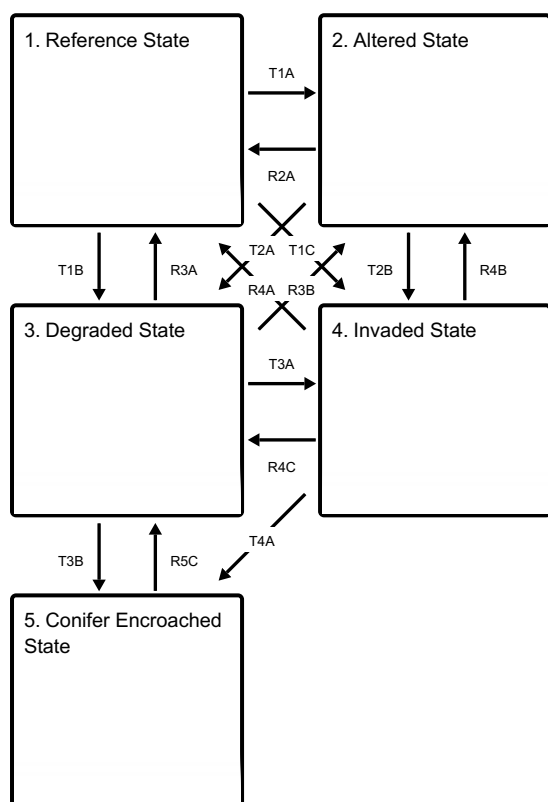

### States 1, 5 and 2 (additional transitions)

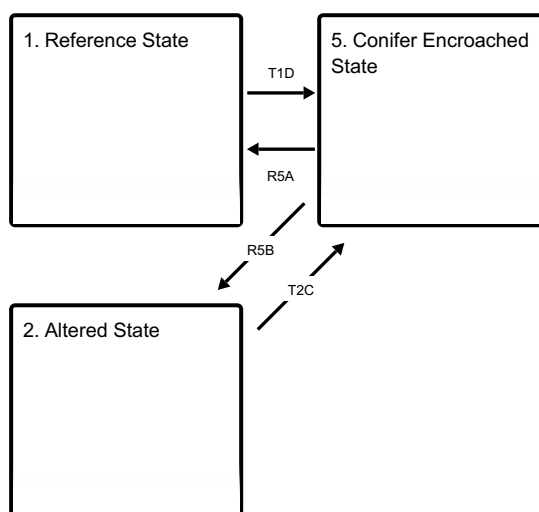

### State 1 submodel, plant communities

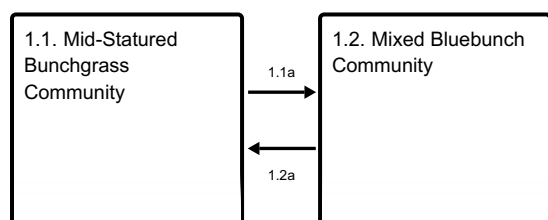

### State 2 submodel, plant communities

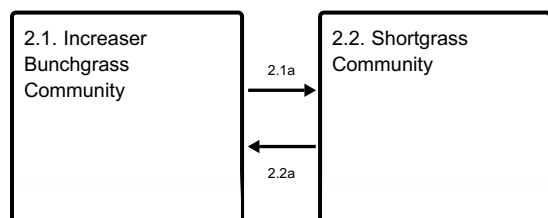

### State 3 submodel, plant communities

3.1. Shrub/Shortgrass  
Community

### State 4 submodel, plant communities

4.1. Invaded  
Community

### State 5 submodel, plant communities

5.1. Conifer  
Encroachment  
Community

## State 1 Reference State

The Reference State of this ecological site consists of two (2) potential plant communities: the 1.1 Mid-Statured Bunchgrass Community and the 1.2 Mixed Bluebunch Community. These are described below but are generally characterized by a mid-statured, cool-season grass community with limited shrub production. Community 1.1 is dominated by rough fescue and is considered the reference, while Community 1.2 has a codominance of rough fescue, bluebunch wheatgrass, green needlegrass, and western wheatgrass with a slight increase in yellow rabbitbrush and Wyoming big sagebrush. These communities may meld into each other due to the varying conditions that occur in Southwest Montana, particularly during dry cycles. Infrequent fire maintained these communities as open, treeless, seral stands of productive herbaceous species with patches of big sagebrush and assorted shrubs. As a result, the Reference State's core concept does not include coniferous trees; however, up to two (2) trees may exist on the landscape when closely situated to forested areas.

### Community 1.1 Mid-Statured Bunchgrass Community

In the Mid-Statured Bunchgrass Community, rough fescue and bluebunch wheatgrass share dominance. Green needlegrass, Idaho fescue, needle and thread, and winterfat are subordinates in the community. Shrub species (big sagebrush, fringed sagewort, and broom snakeweed) remain a minor part of the community, by weight. Spineless horsebrush (*Tetradymia canescens*) and antelope bitterbrush (*Purshia tridentata*) may occupy a small niche. Sandberg bluegrass (*Poa secunda*) and dryland sedges are also common. This state occurs on sites in areas with proper grazing pressure. Careful grazing management of this ecological site is necessary to maintain this deep-rooted bunchgrass community. Rough fescue tends to respond negatively to summer grazing, regardless of grazing intensity (King et al., 1998; Dormaar and Willms, January 1998), while bluebunch wheatgrass lacks resistance to grazing during the critical growing season (spring) and will decline in vigor and production if grazed in the critical growing season more than one year in three (Wilson et al., 1960). This evidence suggests that fall and dormant grazing in this community are most appropriate. The Reference State is moderately resilient and will return to dynamic equilibrium following a relatively short period of stress (such as drought or short-term improper grazing), provided a return of favorable or normal growing conditions and properly managed grazing. As discussed in the Ecological Dynamics section, the natural fire regime restricted shrubs to relatively small portions of the Mid-Statured Bunchgrass Community. Shrub species present may include Wyoming big sagebrush, spineless horsebrush, winterfat, tarragon (*Artemisia drucunculus*), and fringed sagewort. Infrequent fire probably maintained big



sagebrush communities as open, treeless, seral stands of productive herbaceous species with patches of big sagebrush.

### Dominant plant species

- big sagebrush (*Artemisia tridentata*), shrub
- currant (*Ribes*), shrub
- antelope bitterbrush (*Purshia tridentata*), shrub
- Woods' rose (*Rosa woodsii*), shrub
- common snowberry (*Symphoricarpos albus*), shrub
- bluebunch wheatgrass (*Pseudoroegneria spicata*), grass
- rough fescue (*Festuca campestris*), grass
- Idaho fescue (*Festuca idahoensis*), grass
- green needlegrass (*Nassella viridula*), grass
- lupine (*Lupinus*), other herbaceous
- American vetch (*Vicia americana*), other herbaceous
- goldenrod (*Solidago*), other herbaceous
- common yarrow (*Achillea millefolium*), other herbaceous

Table 5. Annual production by plant type

Plant Type	Low (Kg/Hectare)	Representative Value (Kg/Hectare)	High (Kg/Hectare)
Grass/Grasslike	751	885	1009
Shrub/Vine	112	168	224
Forb	90	112	168
Tree	–	–	11
<b>Total</b>	<b>953</b>	<b>1165</b>	<b>1412</b>

Table 6. Ground cover

Tree foliar cover	0%
Shrub/vine/liana foliar cover	10-25%
Grass/grasslike foliar cover	45-55%
Forb foliar cover	5-10%
Non-vascular plants	0-3%
Biological crusts	0-4%
Litter	30-35%
Surface fragments >0.25" and <=3"	0-15%
Surface fragments >3"	0-5%
Bedrock	0%
Water	0%
Bare ground	10-15%

Table 7. Soil surface cover

Tree basal cover	0%
Shrub/vine/liana basal cover	3-5%
Grass/grasslike basal cover	13-18%
Forb basal cover	3-7%
Non-vascular plants	0-1%
Biological crusts	0-4%

Litter	30-35%
Surface fragments >0.25" and <=3"	0-15%
Surface fragments >3"	0-5%
Bedrock	0%
Water	0%
Bare ground	10-15%

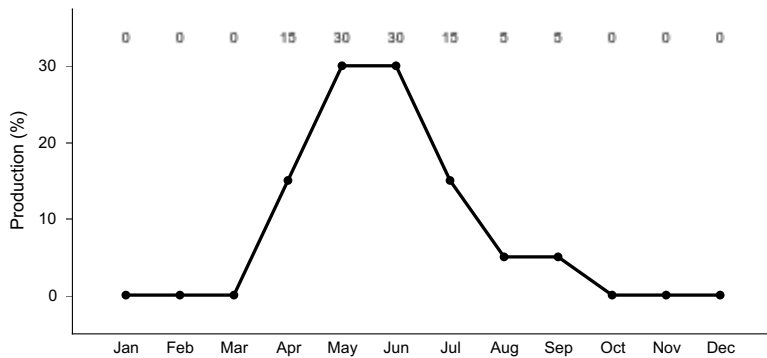

**Figure 8. Plant community growth curve (percent production by month). MT44B032, Dry Uplands. Cool season grass dominated system. Most dry, upland sites located within MLRA 44B LRU A are characterized by early season growth which is mostly complete by Mid-July. Limited fall "green-up" if conditions allow..**

## Community 1.2 Mixed Bluebunch Community

With proper grazing management over time, the Mixed Bluebunch Community (1.2) can come close to the diversity and complexity of the Mid-Statured Bunchgrass Community (1.1). Without active management the site is not likely to return the Reference Plant Community. Western wheatgrass and needle and thread tolerate grazing pressure better than bluebunch wheatgrass and rough fescue. The growing points of tall, deep-rooted bunchgrasses are several inches above the ground, making them very susceptible to continued close grazing (Smoliack et al., 2006), while those of western wheatgrass and needle and thread plants tend to be near the plant base. These plants increase in composition when less palatable and less grazing-tolerant plants decrease due to improper grazing management. Bluebunch wheatgrass is dominant, with rough fescue, green needlegrass, and western wheatgrass sharing subdominance in the Mixed Bluebunch Community (1.2). Other grass species, which are more tolerant to grazing and are likely to increase in number compared to the Mid-Statured Bunchgrass Community, include Sandberg bluegrass (*Poa secunda*), prairie Junegrass, and blue grama (*Bouteloua gracilis*). Some increaser forb species include western yarrow, spiny phlox (*Phlox hoodii*), scarlet globemallow (*Sphaeralcea coccinea*), hairy goldenaster (*Heterotheca villosa*), and pussytoes (*Antennaria* spp.). Fringed sagewort (*Artemisia frigida*) is a shrub that also increases under prolonged drought or heavy grazing and can respond to precipitation that falls in July and August. Heavy, continuous grazing will reduce plant cover, litter, and mulch. The timing of grazing is important on this site because of the moisture limitations beyond June, especially on the drier sites. Bare ground will increase, exposing the soil to erosion. Litter and mulch will be reduced as plant cover declines. As long as the production of rough fescue and bluebunch wheatgrass remains a significant portion of the total biomass production, the site can return to the Mid-Statured Bunchgrass Community (Pathway 1.2A) under proper grazing management and favorable growing conditions. Rough fescue will continue to decrease, and bluebunch wheatgrass will decrease slightly, while needle-and-thread and Idaho fescue will increase until the species composition is nearly equal. Once rough fescue has been reduced to less than 10 percent by weight, it may be difficult for the site to recover to Mid-Statured Bunchgrass Community (1.1). The risk of soil erosion increases when canopy cover decreases below 50 percent. As soil conditions degrade, there will be a loss of organic matter, reduced litter, and reduced soil fertility. Degraded soil conditions increase the difficulty of reestablishing rough fescue and returning to the Mid-Statured Bunchgrass Community (1.1). The Mixed Bluebunch Community (1.2) is the at-risk plant community for this ecological site. When overgrazing continues, increaser species such as western wheatgrass, needle and thread, and native forb species will become more dominant, and this triggers the change to the Altered State (2) or the Degraded State (3). Until the Mixed Bluebunch Community (1.2) crosses the threshold into another state, this community can be managed toward the Rough Fescue Community (1.1) using prescribed grazing and strategic

weed control (if present). It may take several years to achieve this recovery, depending on growing conditions, the vigor of remnant rough fescue and bluebunch wheatgrass plants, and the aggressiveness of the weed treatments. Grazing management that benefits rough fescue tends to be a deferred or rest rotation (Fleenor, July 2011).

### **Pathway 1.1a**

#### **Community 1.1 to 1.2**

Rough fescue and bluebunch wheatgrass lose vigor with improper grazing or extended drought. When vigor declines enough for plants to die or become smaller, species with higher grazing tolerance increase in vigor and production as they access the resources previously used by deep-rooted bunchgrass. The decrease in species composition by weight of rough fescue indicates that the plant community has shifted to the Mixed Bluebunch Community (1.2). The driver for community shift 1.1A is improper grazing management or prolonged drought. This shift is triggered by the loss of vigor of rough fescue, soil erosion, or prolonged drought coupled with improper grazing. Blaisdell (1958) stated that drought and warmer-than-normal temperatures are known to advance plant phenology by as much as one month. During drought years, plants may be especially sensitive or reach a critical stage of development earlier than expected.

### **Pathway 1.2a**

#### **Community 1.2 to 1.1**

The Mixed Bluebunch Community (1.2) will return to the Mid-Statured Bunchgrass Community (1.1) with proper grazing management and appropriate grazing intensity. Favorable moisture conditions will facilitate or accelerate this transition. It may take several years of favorable conditions for the community to transition back to a rough fescue-dominated state. The driver for this community shift (1.2A) is the increased vigor of rough fescue to the point that it represents more than 50 percent of the weight of the grass community. The trigger for this shift is the change in grazing management, which favors rough fescue. In general, conservative grazing management styles such as deferred or rest rotations utilizing light to moderate grazing (less than 50 percent use) coupled with favorable growing conditions like cool, wet springs are these triggers. These systems tend to promote increases in soil organic matter, which promotes microfauna and can increase infiltration rates. Inversely, long periods of rest at a time when this state is considered stable may not result in an increase in rough fescue, and it has been suggested (Noy-Meir 1975) that these long periods of rest or underutilization may actually drive the system to a lower level of stability by creating large amounts of standing biomass, dead plant caudex centers, and gaps in the plant canopy.

## **State 2**

### **Altered State**

This state is characterized by having less than 10 percent mid-statured bunchgrasses. This state is represented by two (2) communities. Community 2.1 is a community dominated by Idaho fescue and needle and thread with small components of deep-rooted bunchgrasses such as rough fescue, bluebunch wheatgrass, and green needlegrass. Community 2.2 has a significantly reduced deep-rooted bunchgrass population that is restricted to protected areas under shrubs. Production in this state tends to be significantly lower than in the Reference State (1). Some native plants tend to increase under prolonged drought and/or heavy grazing practices. A few of these species may include western wheatgrass, needle and thread, Sandberg bluegrass, scarlet globemallow, hairy goldenaster, and fringed sagewort.

### **Community 2.1**

#### **Increaser Bunchgrass Community**

Long-term grazing mismanagement with continuous growing-season pressure will reduce the total productivity of the site and lead to an increase in bare ground. Once plant cover is reduced, the site is more susceptible to erosion and degradation of soil properties. Soil erosion or reduced soil health will result in reduced plant production. This soil erosion or loss of soil fertility indicates the transition to the Altered State (2) because it creates a threshold requiring energy input to return to the Reference State (1). Transition to the Increaser Bunchgrass Community (2.1) may be exacerbated by extended drought conditions. Needle and thread and rhizomatous wheatgrasses dominate this community (2.1). Rough fescue makes up less than 10 percent of species composition by dry weight, and the remaining deep-rooted bunchgrass plants tend to be scattered and low in vigor. Increaser and invader species will be more common and create more competition for deep-rooted bunchgrass. This makes it difficult for them to

quickly respond to a change in grazing management alone. Therefore, an input of energy is required for the community to return to the Reference State (1). Wind and water erosion may be eroding soil from the plant interspaces. Soil fertility is reduced, and soil surface erosion resistance has declined compared to the Reference State (1). This community crossed a threshold compared to the Mixed Bunchgrass Community (1.2) due to the erosion of soil, vegetation composition, loss of soil fertility, or degradation of soil conditions. This results in a critical shift in the ecology of the site. The effects of soil erosion can alter the hydrology, soil chemistry, soil microorganisms, and soil structure to the point where intensive restoration is required to restore the site to another state or community. Changing grazing management alone cannot create sufficient improvement to restore the site within a reasonable time frame. Dormaar (1997) stated that with decreased grazing pressure, a needle and thread/blue grama plant community did not change species composition, but the content of the soil carbon increased. It will require a considerable input of energy to move the site back to the Reference State (1). This state has lost soil or vegetation attributes to the point that recovery to the Reference State (1) will require reclamation efforts, i.e., soil rebuilding, intensive mechanical treatments, and/or reseeding. The transition to this state could result from overgrazing, especially repeated early-season grazing coupled with extensive drought. If heavy grazing continues, plant cover, litter, and mulch will continue to decrease, and bare ground will increase, exposing the soil to accelerated erosion. Litter and mulch will move off-site as plant cover declines. The Increaser Bunchgrass Community will then shift to the Shortgrass Community (2.2) or the Degraded State, depending on the level of disturbance. Introduction or expansion of invasive species will further drive the plant community into the Invaded State (4).

## **Community 2.2 Shortgrass Community**

With continued mismanagement of grazing, especially coupled with prolonged drought, needle and thread will decrease in vigor. The bunchgrasses will decline in production as plants die or become smaller, and species with higher grazing tolerance (such as western wheatgrass) will increase in vigor and production as they respond to resources previously used by the bunchgrasses. These less desirable, shallow-rooted species will become codominant in this community along with mid-statured bunchgrasses such as needle and thread and Idaho fescue. Shrubs will become more competitive for limited moisture as bare ground and soil erosion increase. Remaining deep-rooted bunchgrasses such as rough fescue and bluebunch wheatgrass are nearly absent in this community; however, remnant populations may exist under shrub canopy away from grazing pressure.

### **Pathway 2.1a Community 2.1 to 2.2**

The driver for community shift 2.1a is continued improper grazing management. This shift is triggered by the continued loss of bunchgrass vigor, especially the remaining trace amounts of rough fescue and bluebunch on the site. Shrubs will protect these less vigorous bunchgrasses. The mid- and short-statured grasses will become more competitive and will become co-dominant with the bunchgrasses. Shrubs will increase their canopy cover but stay at about 15 percent.

### **Pathway 2.2a Community 2.2 to 2.1**

If proper grazing management is implemented, needle and thread may regain its vigor and move towards the Increaser Bunchgrass Community (2.1). This will give grasses an advantage over invading shrubs before too much competition takes place. The advantage to grasses comes from following a conservative grazing plan where utilization is reduced and rest or deferment is incorporated since the transition from Plant Community 2.1 to Plant Community 2.2 is likely caused by repeated heavy utilization. Van Poolen and Lacey (1979) found that forage production increased by an average of 35 percent on western ranges when converting heavy to moderate utilization (less than 50 percent). Shrub removal and favorable growing conditions can accelerate this process. If the site contains Wyoming big sagebrush (*Artemisia tridentata* spp. *wyomingensis*), low-intensity fire or mechanical treatment (Wambolt 1986) could reduce shrub competition and allow for increased vigor and the reestablishment of grass species.

## **State 3 Degraded State**

Degraded State lacks mid-statured bunchgrasses. Sandberg bluegrass and prairie Junegrass are dominant grasses, and increaser shrubs nearly replace larger shrub species. Larger shrub species that remain are heavily hedged. Likely a terminal state (e.g., restoration will likely be impossible or unsuccessful and require major energy inputs).

**Characteristics and indicators.** increased bare ground (excess of 25 percent) annual grasses common complete removal of deep rooted tall bunchgrasses and replaced with sandberg bluegrass, western wheatgrass, and blue grama sagebrush nearly gone and replaced with cactus rabbitbrush and broom snakeweed

### **Community 3.1 Shrub/Shortgrass Community**

Soil loss continues, and subsequent losses of soil organic matter create conditions where native perennial grasses are reduced to less than 50 percent of their total production. Grass and forb cover may be very sparse or clumped. Weeds, annual species, and shrubs dominate the plant community. Mid-statured bunchgrass species may exist, but only in small patches. This could occur due to a failure to adjust stocking rates for declining forage production due to increased invasive dominance. In the most severe stages of degradation, there is a significant amount of bare ground, and large gaps occur between plants. Potential exists for soils to erode to the point that irreversible damage may occur. This is a critical shift in the ecology of the site. Soil erosion combined with a lack of organic matter deposition due to sparse vegetation creates changes to the hydrology, soil chemistry, soil microorganisms, and soil structure to the point where intensive restoration is required to restore the site to another state or community. Changing management (i.e., improving grazing management) cannot create sufficient change to restore the site within a reasonable time frame. This state is characterized by soil surface degradation and little plant soil surface cover. The forb component changes to being dominated by spiny phlox (*Phlox hoodii*), and shrub canopy cover is usually greater than 20 percent. Big sagebrush is replaced with a dominant community of broom snakeweed, rubber rabbitbrush, fringed sagewort, and plains prickly pear cactus. This state has lost soil or vegetation attributes to the point that recovery to the Reference State will require reclamation efforts, i.e., soil rebuilding, intensive mechanical treatments, and/or reseeding. This plant community may be in a terminal state and will not return to the reference state because of degraded soil conditions and the loss of higher successional native plant species. Key factors in the approach to transition include: a decrease in grass canopy cover and production; an increase in shrub canopy cover; increases in mean bare patch size; increases in soil crusting; decreases in the cover of cryptobiotic crusts; decreases in soil aggregate stability; and/or evidence of erosion, including water flow patterns and litter movement.

### **State 4 Invaded State**

The Invaded State is identified as being in the exponential growth phase of invader abundance where control is a priority. Dominance (or relative dominance) of noxious or invasive species reduces species diversity, forage production, wildlife habitat, and site protection. A level of 15 percent invasive species composition by dry weight indicates that a substantial energy input will be required to create a shift to the grassland state (herbicide, mechanical treatment), even with a return to proper grazing management or favorable growing conditions. Prescriptive grazing can be used to manage invasive species. In some instances, carefully targeted grazing (sometimes in combination with other treatments) can reduce or maintain the species composition of invasive species. These communities within this state will follow a pathway if the invasive or noxious species continue to thrive without mechanical, biological, or chemical control methods to exceed 50 percent of species composition by dry weight. The invasive nature of the weed outcompetes the present plant community. Once the weed reaches its maximum population level for this site, effective control is unlikely without massive resource inputs. Ecological processes at the site may change after invading species have established and spread (Walker and Smith 1997).

### **Community 4.1 Invaded Community**

Communities in this state may be structurally indistinguishable from the Reference State except that invasive or noxious species exceed 15 percent of species composition by dry weight. This state may also include a community similar to the Degraded State (3) except that invasive or noxious species exceed 15 percent of species composition by dry weight. Although there is no research to document the level of 15 percent, this is estimated to be the point in

the invasion process following the lag phase based on the interpretation of Masters and Sheley (2001). For aggressive invasive species (i.e., spotted knapweed), a 15 percent threshold could be less than 10 percent. Early in the invasion process, there is a lag phase where the invasive plant populations remain small and localized for long periods before expanding exponentially (Hobbs and Humphries 1995). Production in the invaded community may vary greatly. A site dominated by Kentucky bluegrass or spotted knapweed, where soil fertility and chemistry remain near reference, may have production near that of the reference community. A site with degraded soils and an infestation of cheatgrass may produce only 10 to 20 percent of the reference community. Once invasive species dominate the site, either in species composition by weight or in their impact on the community, the threshold has been crossed to the Invaded State (4). As invasive species such as spotted knapweed, cheatgrass, and leafy spurge become established, they become very difficult to eradicate. Therefore, considerable effort should be put into preventing plant communities from crossing a threshold into the Invaded State (4) through early detection and proper management. Preventing new invasions is by far the most cost-effective control strategy and typically places an emphasis on education. Control measures used on the noxious plant species impacting this ecological site include chemical, biological, and cultural control methods. The best success has been found with an integrated pest management (IPM) strategy that incorporates one or several of these options along with education and prevention efforts (DiTomaso 2000).

## **State 5 Conifer Encroached State**

Rocky Mountain juniper (*Juniperus scopulorum*), Douglas fir (*Pseudotsuga menziesii*), and ponderosa pine (*Pinus ponderosa*) encroachment is limited on this ecological site and is generally focused in areas where the mountains of MLRA 44B transition quickly to MLRA 43B. Under the Reference State, up to two (2) stem per acres of conifers may exist as part of long-term fire suppression; however the core concept of this ecological site is to express no coniferous trees. Conifer Encroached State consists of up to 4 potential phases. The Early Phase, Mid Phase, Late Phase, and Closed Phase are defined by the amount of encroachment and age class of the stand. This state typically occurs in response to a combination of long-term fire suppression, grazing history, and increased atmospheric carbon dioxide. The trigger for transition is a coniferous expansion of more than 2 stems per acre.

### **Community 5.1 Conifer Encroachment Community**

Restoration efforts may simply focus on the removal of coniferous trees and shrubs to restore the Conifer Encroached State (5) to the Reference State (1), depending on the level of conifer canopy cover and its impact on rangeland health. If following and utilizing the phases established by Miller et al., management and restoration methods will vary. A majority of the conifer encroachment in MLRA 44B will fall into the early two phases of Miller's phases. When conifers are removed through brush management and/or prescribed fire, Phase I may reveal none-to-slight to moderate deviations from rangeland health. If mechanical removal of conifers is utilized, no grazing management is needed, assuming relatively conservative management had been used prior to treatment. If prescribed fire is utilized, short-term grazing deferment and/or rest are suggested. In a short period of time, removing a Phase I encroachment will return the site to its original state. Proactive pest management is encouraged. Phase II encroachment may require a more intensive mechanical removal of trees and shrubs, with prescribed fire not being a feasible method of control as this community may be at risk of catastrophic fire due to canopy density. Phase II displays a moderate departure from Reference, suggesting an overall instability of the site such as reduced herbaceous production, reduced functional and structural groups (e.g., reduced mid-statured bunchgrasses), increased rill frequency and length, and possibly more bare ground. Increased post-treatment grazing management may be necessary. Grazing management may be as simple as short-term growing season deferment; however, long-term rest may be necessary in the latter stages of Phase II encroachment. The latter stages of Phase II encroachment will likely require some short-term erosion mitigation, such as straw waddles, as well as range planting and/or critical area planting to re-establish any loss of native herbaceous plants, particularly mid-statured cool-season bunchgrasses. Phase III encroachment canopy cover resembles forested sites with larger trees and shrubs. Prior to any prescribed burning, forest management-style tree removal (removal of woody debris and logs from the site) will be required to prevent the fire from burning too hot. The result of a prescribed fire on this site is typically unknown as seed sources of native herbaceous plants are usually limited to small patches. Since the Shallow Droughty ecological site for 44B LRU 01 Subset B is a dry site, herbaceous plants will likely have been depleted under a Phase III encroachment. This means there is an opportunity for large areas of bare ground, increased rills, and, in some cases, gully erosion. Post-treatment will require range planting and/or critical area seeding, erosion control, pest management, and possibly soil carbon amendments (biochar). Grazing management

(primarily rest) will be required to ensure the establishment of any new seedlings.

## **Transition T1A**

### **State 1 to 2**

The Reference State (1) transitions to the Altered State (2) if mid-statured bunchgrasses, by dry weight, decreases to below 15 percent or if bare ground cover increases beyond 15 percent. The driver for this transition is the loss of taller bunchgrasses, which creates open areas in the plant canopy with bare soil. Soil erosion results in decreased soil fertility, driving transitions to the Altered State. There are several other key factors signaling the approach of transition T1A: increases in soil physical crusting, decreases in cover of cryptogamic crusts, decreases in soil surface aggregate stability, and/or evidence of erosion including water flow patterns, development of plant pedestals, and litter movement. The trigger for this transition is improper grazing management and/or long-term drought, leading to a decrease in rough fescue composition to less than 10 percent and a reduction in total plant canopy cover.

## **Transition T1B**

### **State 1 to 3**

The Reference State (1) transitions to the Degraded State (3) when rough fescue and bluebunch are removed from the plant community and needle and thread is subdominant over short-statured bunchgrasses such as Sandberg bluegrass. This transition differs from T1A in that it is generally a rapid transition and usually associated with disturbances such as repeated overgrazing or heavy human traffic. This rapid transition is generally realized where livestock are confined to small pastures for long periods of time, such as horse pastures and calving lots. The driver for this transition is the loss of taller bunchgrasses, which creates openings in the canopy and exposes bare soil. Soil erosion results in decreased soil health, driving transitions to the Degraded State. There are several other key factors signaling the approach of transition T1B: increases in soil physical crusting, decreases in cover of cryptogamic crusts, decreases in soil surface aggregate stability, and/or evidence of erosion including water flow patterns, development of plant pedestals, and litter movement. The trigger for this transition is improper grazing management, long term drought, and/or heavy human disturbance.

## **Transition T1C**

### **State 1 to 4**

Healthy plant communities are most resistant to invasion. However, regardless of grazing management, without some form of active weed management (chemical, mechanical, or biological control) and prevention, the Reference State (1) can transition to the Invaded State (4) in the presence of aggressive invasive species such as spotted knapweed, leafy spurge, and cheatgrass. This will occur even if the reference community is thriving. The Central Rocky Mountain Valleys tend to resist invasion by cheatgrass; however, repeated heavy grazing or intense human activities can open the interspaces of the bunchgrass community and allow for encroachment. Long-term stress conditions for native species (e.g., overgrazing, drought, and fire) accelerate this transition. If populations of invasive species reach critical levels, the site transitions to the Invaded State. The trigger for this transition is the presence of aggressive invasive species. The species composition by dry weight of invasive species approaches 10 percent.

## **Transition T1D**

### **State 1 to 5**

The transition from the Reference State (1) to the Conifer Encroached State (5) is driven primarily by long-term fire suppression, but heavy grazing may contribute to increased bare ground for seeding sites. Encroachment occurs most quickly within 200 feet of the seed source. The trigger for transition is a conifer stem count greater than two (2) per acre.

## **Restoration pathway R2A**

### **State 2 to 1**

The Altered State (2) has lost soil or vegetation attributes to the point that recovery to the Reference State (1) will require reclamation efforts such as soil rebuilding, intensive mechanical and cultural treatments, and/or

revegetation. Examples of mechanical treatment may be brush control, while cultural treatments may include prescribed grazing, targeted brush browsing, or prescribed burning. Low intensity prescribed fires to reduce competitive increaser plants such as needle and thread and Sandberg bluegrass. A low-intensity fire will also reduce Wyoming big sagebrush densities. In areas with the potential for annual grass infestation, fire should be carefully planned or avoided. The drivers for this restoration pathway are reclamation efforts along with proper grazing management.

### **Transition T2A** **State 2 to 3**

As improper grazing management continues, the vigor of bunch grasses will decrease and the shorter grasses and shrubs will increase, leading to the Degraded Shortgrass State (3). Prolonged drought will provide a competitive advantage to shrubs, allowing them to become co-dominant with grasses. Shrub canopy will increase above 15 percent canopy cover. Key transition factors include: an increase in native shrub canopy cover; a reduction in bunchgrass production; a decrease in total plant canopy cover and production; increases in mean bare patch size; increases in soil crusting; decreases in the cover of cryptobiotic crusts; decreases in soil aggregate stability; and/or evidence of erosion, including water flow patterns and litter movement.

### **Transition T2B** **State 2 to 4**

Invasive species can occupy the Altered State (2) and drive it to the Invaded State (4). The Altered State is at risk if invasive seeds and/or other viable material are present. The driver for this transition is more than 10 percent dry weight of invasive species.

### **Transition T2C** **State 2 to 5**

The transition from the Altered State (2) to the Conifer Encroached State (5) is driven primarily by long-term fire suppression, but heavy grazing may contribute to increased bare ground for seeding sites. Encroachment occurs most quickly within 200 feet of the seed source. The trigger for transition is a conifer stem count greater than two (2) per acre.

### **Restoration pathway R3A** **State 3 to 1**

The Degraded State (3) has lost soil or vegetation attributes to the point that recovery to the Reference State (1) will require reclamation efforts, such as soil rebuilding, intensive mechanical treatments, and/or revegetation. Studies suggest (Whitford et al. 1989) that a mulch with a high carbon to nitrogen ratio, such as wood chips or bark, in low moisture scenarios can be beneficial for slow mobilization of plant-available nitrogen. Biochar may also be added to the system to improve Soil Organic Carbon (SOC) which should improve Cation Exchange Capacity (CEC), microbial activity, and hydrologic conductivity (Stavi 2012). The drivers for the restoration pathway are the removal of increaser species, restoration of native bunchgrass species, persistent management of invasives and shrubs, and proper grazing management. Without continued control, invasive and shrub species are likely to return (probably rapidly) due to the presence of seeds and/or other viable material in the soil and management-related increases in soil disturbance.

### **Restoration pathway R3B** **State 3 to 2**

Since the bunchgrass plant community has been significantly reduced, restoration to the Altered State (2) is unlikely unless a seed source is available. However, if a sufficient amount of grass remains on the site, chemical application and/or biological control, in conjunction with proper grazing management, can reduce the amount of shrubs and invasive species and restore the site to the Shortgrass Community (2.2). Low-intensity fire can be utilized to reduce Wyoming big sagebrush competition and allow the reestablishment of grass species. Caution must be used when considering fire as a management tool on sites with fire tolerant shrubs such as rubber rabbitbrush, as these shrubs will sprout after a burn. Broom snakeweed and fringed sagewort may or may not re-sprout depending on conditions



(USDA Forest Service, 2011).

### **Transition T3A** **State 3 to 4**

Invasive species can occupy the Degraded State (3) and drive it to the Invaded State (4). The Degraded State is at risk of this transition occurring if invasive seeds or viable material are present. The driver for this transition is the presence of critical population levels (more than 10 percent dry weight of invasive species). The trigger is the presence of seeds or viable material from invasive species. This state has sufficient bare ground that the transition could occur simply due to the presence or introduction of invasive seeds or viable material. This is particularly true of aggressive invasive species such as spotted knapweed. This transition could be assisted by overgrazing (failure to adjust stocking rate to declining forage production), a long-term lack of fire, or an extensive drought.

### **Transition T3B** **State 3 to 5**

The transition from the Degraded State (3) to the Conifer Encroached State (5) is driven primarily by heavy grazing; contributing to increased bare ground for seeding sites. Encroachment occurs most quickly within 200 feet of the seed source. The trigger for transition is a conifer stem count greater than two (2) per acre.

### **Restoration pathway R4A** **State 4 to 1**

If invasive species are removed before remnant populations of bunchgrass have been drastically reduced, the Invaded State (4) can return to the Reference State. The driver for the reclamation pathway is weed management with reseeding. Continued Integrated Pest Management (IPM) will be required as many of the invasive species that can occupy the Invaded State have extended dormant seed life.

### **Restoration pathway R4B** **State 4 to 2**

If invasive species are removed before remnant populations of bunchgrass have been drastically reduced, the Invaded State (4) can return to the Altered State. The driver for the reclamation pathway is weed management with reseeding. Continued Integrated Pest Management (IPM) will be required as many of the invasive species that can occupy the Invaded State have extended dormant seed life.

### **Restoration pathway R4C** **State 4 to 3**

If invasive species are removed before remnant populations of bunchgrass have been drastically reduced, the Invaded State (4) can return to the Degraded State. The driver for the reclamation pathway is weed management with reseeding. Continued Integrated Pest Management (IPM) will be required as many of the invasive species that can occupy the Invaded State have extended dormant seed life.

### **Transition T4A** **State 4 to 5**

The transition from the Invaded State (4) to the Conifer Encroached State (5) is driven primarily by heavy grazing; contributing to increased bare ground for seeding sites. Encroachment occurs most quickly within 200 feet of the seed source. The trigger for transition is a conifer stem count greater than two (2) per acre.

### **Restoration pathway R5A** **State 5 to 1**

Restoration efforts may simply focus on the removal of coniferous trees and shrubs to restore the Conifer Encroached State (5) to the Reference State (1), depending on the level of conifer canopy cover and its impact on rangeland health. If following and utilizing the phases established by Miller et al., management and restoration

methods will vary. A majority of the conifer encroachment in MLRA 44B will fall into the early two phases of Miller's phases. When conifers are removed through brush management and/or prescribed fire, Phase I may reveal none-to-slight to moderate deviations from rangeland health. If mechanical removal of conifers is utilized, no grazing management is needed, assuming relatively conservative management had been used prior to treatment. If prescribed fire is utilized, short-term grazing deferment and/or rest are suggested. In a short period of time, removing a Phase I encroachment will return the site to its original state. Proactive pest management is encouraged. Phase II encroachment may require a more intensive mechanical removal of trees and shrubs, with prescribed fire not being a feasible method of control as this community may be at risk of catastrophic fire due to canopy density. Phase II displays a moderate departure from Reference, suggesting an overall instability of the site such as reduced herbaceous production, reduced functional and structural groups (e.g., reduced mid-statured bunchgrasses), increased rill frequency and length, and possibly more bare ground. Increased post-treatment grazing management may be necessary. Grazing management may be as simple as short-term growing season deferment; however, long-term rest may be necessary in the latter stages of Phase II encroachment. The latter stages of Phase II encroachment will likely require some short-term erosion mitigation, such as straw wattles, as well as range planting and/or critical area planting to re-establish any loss of native herbaceous plants, particularly mid-statured cool-season bunchgrasses. Phase III encroachment canopy cover resembles forested sites with larger trees and shrubs. Prior to any prescribed burning, forest management-style tree removal (removal of woody debris and logs from the site) will be required to prevent the fire from burning too hot. The result of a prescribed fire on this site is typically unknown as seed sources of native herbaceous plants are usually limited to small patches. Since the Shallow Droughty ecological site for 44B LRU 01 Subset B is a dry site, herbaceous plants will likely have been depleted under a Phase III encroachment. This means there is an opportunity for large areas of bare ground, increased rills, and, in some cases, gully erosion. Post-treatment will require range planting and/or critical area seeding, erosion control, pest management, and possibly soil carbon amendments (biochar). Grazing management (primarily rest) will be required to ensure the establishment of any new seedlings.

## **Restoration pathway R5B**

### **State 5 to 2**

The Conifer Encroached State (5) Phases I and II will generally resemble the Altered State (2) on this site. If following and utilizing the phases established by Miller et al., management and restoration methods will vary. A majority of the conifer encroachment in MLRA 44B will fall into the early two phases of Miller's phases. When conifers are removed through brush management and/or prescribed fire, Phase I may show none-to-slight to moderate deviations from rangeland health. If mechanical removal of conifers is utilized, no grazing management is needed, assuming relatively conservative management had been used prior to treatment. If prescribed fire is utilized, short-term grazing deferment and/or rest are suggested. In a short period of time, removing a Phase I encroachment will return the site to its original state. Proactive pest management is encouraged. Phase II encroachment may require a more intensive mechanical removal of trees and shrubs, with prescribed fire not being a feasible method of control as this community may be at risk of catastrophic fire due to canopy density. Phase II displays a moderate departure from Reference, suggesting an overall instability of the site such as reduced herbaceous production, reduced functional and structural groups (e.g., reduced mid-statured bunchgrasses), increased rill frequency and length, and possibly more bare ground. Increased post-treatment grazing management may be necessary. Grazing management may be as simple as short-term growing season deferment; however, long-term rest may be necessary in the latter stages of Phase II encroachment. The latter stages of Phase II encroachment will likely require some short-term erosion mitigation such as straw wattles as well as range planting and/or critical area planting to re-establish any loss of native herbaceous plants, particularly mid-statured cool-season bunchgrasses. Phase III encroachment canopy cover resembles forested sites with larger trees and shrubs. Prior to any prescribed burning, forest management-style tree removal (removal of woody debris and logs from the site) will be required to prevent the fire from burning too hot. The result of a prescribed fire on this site is typically unknown as seed sources of native herbaceous plants are usually limited to small patches. Since the Shallow Droughty ecological site for 44B LRU 01 Subset B is a dry site, herbaceous plants will likely have been depleted under a Phase III encroachment. This means there is an opportunity for large areas of bare ground, increased rills, and, in some cases, gully erosion. Post-treatment will require range planting and/or critical area seeding, erosion control, pest management, and possibly soil carbon amendments (biochar). Grazing management (primarily rest) will be required to ensure the establishment of any new seedlings.

## **Restoration pathway R5C**

### **State 5 to 3**

The Conifer Encroached State (5) Phases II and III may resemble the Degraded State (3) on this site. If following and utilizing the phases established by Miller et al., management and restoration methods will vary. An overwhelming majority of the conifer encroachment in MLRA 44B will fall into the early two phases of Miller's phases. This restoration pathway is extremely rare because managing a degraded state is typically not cost-effective for land managers. When conifers are removed through brush management and/or prescribed fire, Phase I may show none-to-slight to moderate deviations from rangeland health. If mechanical removal of conifers is utilized, no grazing management is needed, assuming relatively conservative management had been used prior to treatment. If prescribed fire is utilized, short-term grazing deferment and/or rest are suggested. Given a short time removal of a Phase I encroachment will recover to Reference. Proactive pest management is encouraged. Phase II Encroachment may require a more intensive mechanical removal of trees and shrubs, with prescribed fire not being a feasible method of control as this community may be at risk of catastrophic fire due to canopy density. Phase II displays a moderate departure from Reference, suggesting an overall instability of the site such as reduced herbaceous production, reduced functional and structural groups (e.g., reduced mid-statured bunchgrasses), increased rill frequency and length, and possibly more bare ground. Increased post-treatment grazing management may be necessary. Grazing management may be as simple as short-term growing season deferment; however, long-term rest may be necessary in the latter stages of Phase II encroachment. The latter stages of Phase II encroachment will likely require some short-term erosion mitigation, such as straw waddles, as well as range planting and/or critical area planting to re-establish any loss of native herbaceous plants, particularly mid-statured cool-season bunchgrasses. Phase III Encroachment canopy cover resembles forested sites with larger trees and shrubs. Forest management style tree removal (woody debris and logs removed from the site) will be necessary prior to any prescribed burning as to prevent the fire from burning too hot. The results of a prescribed fire on this site are typically unknown as seed sources of native herbaceous plants are usually limited to small patches. Since the Shallow Droughty ecological site for 44B LRU 01 Subset B is a dry site, herbaceous plants will likely have been depleted under a Phase III encroachment. This means there is an opportunity for large areas of bare ground, increased rills, and, in some cases, gully erosion. Post-treatment will require range planting and/or critical area seeding, erosion control, pest management, and possibly soil carbon amendments (biochar). Grazing management (primarily rest) will be required to ensure the establishment of any new seedlings.

## Additional community tables

Table 8. Community 1.1 plant community composition

Group	Common Name	Symbol	Scientific Name	Annual Production (Kg/Hectare)	Foliar Cover (%)
<b>Grass/Grasslike</b>					
1	<b>Mid-Statured Bunchgrasses</b>			560–695	
	bluebunch wheatgrass	PSSP6	<i>Pseudoroegneria spicata</i>	420–673	35–60
	rough fescue	FECA4	<i>Festuca campestris</i>	336–448	20–35
	green needlegrass	NAVI4	<i>Nassella viridula</i>	112–168	10–20
	Indian ricegrass	ACHY	<i>Achnatherum hymenoides</i>	0–45	1–5
2	<b>Rhizomatous Grasses</b>			67–140	
	western wheatgrass	PASM	<i>Pascopyrum smithii</i>	45–112	2–5
	thickspike wheatgrass	ELLA3	<i>Elymus lanceolatus</i>	0–112	0–5
	plains reedgrass	CAMO	<i>Calamagrostis montanensis</i>	22–45	1–2
3	<b>Shortgrasses/grasslikes</b>			67–140	
	needle and thread	HECO26	<i>Hesperostipa comata</i>	45–112	7–13
	Idaho fescue	FEID	<i>Festuca idahoensis</i>	45–84	5–10
	Sandberg bluegrass	POSE	<i>Poa secunda</i>	22–67	3–7
	prairie Junegrass	KOMA	<i>Koeleria macrantha</i>	22–67	3–5
	threadleaf sedge	CAFI	<i>Carex filifolia</i>	22–67	3–5
	sedge	CAREX	<i>Carex</i>	0–45	0–2
	blue grama	BOGR2	<i>Bouteloua gracilis</i>	0–11	0–1
<b>Forb</b>					

4	<b>Forbs</b>			90–112	
	lupine	LUPIN	<i>Lupinus</i>	22–34	1–3
	American vetch	VIAM	<i>Vicia americana</i>	22–34	1–3
	scarlet globemallow	SPCO	<i>Sphaeralcea coccinea</i>	11–22	1–2
	dotted blazing star	LIPU	<i>Liatris punctata</i>	0–22	0–1
	spiny phlox	PHHO	<i>Phlox hoodii</i>	0–11	0–1
	deathcamas	ZIGAD	<i>Zigadenus</i>	0–6	0
<b>Shrub/Vine</b>					
5	<b>Shrubs</b>			112–196	
	big sagebrush	ARTR2	<i>Artemisia tridentata</i>	112–196	10–20
	antelope bitterbrush	PUTR2	<i>Purshia tridentata</i>	0–45	0–5
	common snowberry	SYAL	<i>Symphoricarpos albus</i>	11–45	1–5
	Woods' rose	ROWO	<i>Rosa woodsii</i>	0–45	0–3
	yellow rabbitbrush	CHVI8	<i>Chrysothamnus viscidiflorus</i>	0–45	0–2
	spineless horsebrush	TECA2	<i>Tetradymia canescens</i>	0–22	0–1
	currant	RIBES	<i>Ribes</i>	11–22	0–1
6	<b>Subshrubs</b>			11–45	
	winterfat	KRLA2	<i>Krascheninnikovia lanata</i>	11–34	0–2
	prairie sagewort	ARFR4	<i>Artemisia frigida</i>	0–11	0–1
	broom snakeweed	GUSA2	<i>Gutierrezia sarothrae</i>	0–11	0–1
<b>Tree</b>					
7	<b>Coniferous Trees and Tall Shrubs</b>			0–11	
	ponderosa pine	PIPOS	<i>Pinus ponderosa var. scopulorum</i>	0–11	0–1
	Rocky Mountain juniper	JUSC2	<i>Juniperus scopulorum</i>	0–11	0–1
	Douglas-fir	PSME	<i>Pseudotsuga menziesii</i>	0–11	0–1

## Animal community

The Shallow Droughty ecological site provides a variety of wildlife habitats for an array of species. Prior to the settlement of this area, large herds of antelope, elk, and bison roamed. Though the bison have been replaced, mostly with domesticated livestock, elk and antelope still frequently utilize this largely intact landscape.

Greater sage grouse may be present on sites with suitable habitat, typically requiring a minimum of 15 percent sagebrush canopy cover (Wallestad 1975). Mid-Statured Bunchgrass Community (1.1) is likely to have this minimum sagebrush cover for sage grouse presence given its low to moderate sagebrush canopy cover. Also, the potentially diverse forb component of the Reference State may provide important early-season (spring) foraging habitat for the greater sage grouse.

Managed livestock grazing is suitable on this site due to the potential to produce an abundance of high-quality forage. In order to maintain the productivity of the Shallow Droughty site, grazing on adjoining sites with less production must be managed carefully to be sure utilization on this site is not excessive. Management objectives should include maintenance or improvement of the native plant community. Careful management of the timing and duration of grazing is important. Shorter grazing periods and adequate deferment during the growing season are recommended for plant maintenance, health, and recovery. According to McLean et al., early-season defoliation of bluebunch wheatgrass can result in high mortality and reduced vigor in plants. They also suggest, based on prior studies, that regrowth is necessary before dormancy to reduce injury of bluebunch.

The grazing season has more influence on winterfat than grazing intensity. Late winter or early spring grazing is

detrimental. However, early winter grazing may actually be beneficial (Blaisdell 1984).

Continual non-prescribed grazing of this site will be detrimental, will alter the plant composition and production over time, and will result in the transition to the Altered State. The transition to other states will depend on the duration of poorly managed grazing as well as other circumstances such as weather conditions and fire frequency.

The Altered State is subject to further degradation to the Degraded State or Invaded State. Management should focus on grazing management strategies that will prevent further degradation, such as seasonal grazing deferment or winter grazing where feasible. Communities within this state are still stable and healthy under proper management. Forage quantity and/or quality may be substantially decreased from the Reference State.

Grazing is possible in the Invaded State. Invasive species are generally less palatable than native grasses. Forage production is typically greatly reduced in this state. Due to the aggressive nature of invasive species, sites in the Invaded State face an increased risk of further degradation. Grazing has to be carefully managed to avoid further soil loss and degradation and possible livestock health issues.

Prescriptive grazing can be used to manage invasive species. In some instances, carefully targeted grazing (sometimes in combination with other treatments) can reduce or maintain the species composition of invasive species. In the Degraded State, grazing may be possible but is generally not economically and/or environmentally sustainable.

## **Hydrological functions**

The hydrologic cycle functions best in the Reference State (1) with good infiltration and deep percolation of rainfall; however, the cycle degrades as the vegetation community declines. Rapid rainfall infiltration, high soil organic matter, good soil structure, and good porosity accompany high bunchgrass canopy cover. High ground cover reduces raindrop impact on the soil surface, which keeps erosion and sedimentation transport low. Water leaving the site will have a minimal sediment load, which allows for high water quality in associated streams. High rates of infiltration will allow water to move below the rooting zone during periods of heavy rainfall. The Mid-Statured Bunchgrass Community (1.1) should have no rills or gullies present, and drainage ways should be vegetated and stable. Water flow patterns, if present, will be barely observable. Plant pedestals are essentially nonexistent. Plant litter remains in place and is not moved by wind or water.

Improper grazing management results in a community shift to the Mixed Bluebunch Community (1.2). This plant community has a similar canopy cover, but the bare ground will be less than 15 percent. Therefore, the hydrologic cycle is functioning at a level similar to the water cycle in the Mid-Statured Bunchgrass Community (1.1). Compared to the Mid-Statured Bunchgrass Community (1.1), infiltration rates are slightly reduced and surface runoff is slightly higher.

In the Shortgrass Community (2.2), Degraded State (3) and the Invaded State (4) canopy and ground cover are greatly reduced compared to the Reference State (1), which impedes the hydrologic cycle. Infiltration will decrease and runoff will increase due to reduced ground cover, the presence of shallow-rooted species, rainfall splash, soil capping, reduced organic matter, and poor structure. Sparse ground cover and decreased infiltration can combine to increase the frequency and severity of flooding within a watershed. Soil erosion is accelerated, the quality of surface runoff is poor, and sedimentation increases.

The hydrology of the Conifer Encroached State (5) is highly variable, but studies suggest that an increased tree canopy affects the interception of rainfall as well as the amount of available soil moisture for herbaceous vegetation. This can negatively affect infiltration and increase runoff.

## **Recreational uses**

This site provides recreational opportunities for hiking, horseback riding, big game and upland bird hunting. Some forbs have flowers that appeal to photographers. This site provides valuable open space.

## **Wood products**

none

## Other products

none

## Inventory data references

Information presented was derived from the site's Range Site Description, NRCS clipping data, literature, field observations, and personal contacts with range-trained personnel (i.e., used professional opinion of agency specialists, observations of land managers, and outside scientists).

## References

. Fire Effects Information System. <http://www.fs.fed.us/database/feis/>.

. 2021 (Date accessed). USDA PLANTS Database. <http://plants.usda.gov>.

Arno, S.F. and G.E. Gruell. 1982. Fire History at the Forest-Grassland Ecotone in Southwestern Montana. *Journal of Range Management* 36:332–336.

Barrett, H. 2007. *Western Juniper Management: A Field Guide*.

Bestelmeyer, B., J.R. Brown, J.E. Herrick, D.A. Trujillo, and K.M. Havstad. 2004. Land Management in the American Southwest: a state-and-transition approach to ecosystem complexity. *Environmental Management* 34:38–51.

Bestelmeyer, B. and J. Brown. 2005. State-and-Transition Models 101: A Fresh look at vegetation change.

Blaisdell, J.P. 1958. Seasonal development and yield of native plants on the Upper Snake River Plains and their relation to certain climate factors.

Blaisdell, J.P. and R.C. Holmgren. 1984. Managing Intermountain Rangelands--Salt-Desert Shrub Ranges. General Tech Report INT-163. USDA Forest Service, Intermountain Forest and Range Experiment Station, Ogden, UT. 52.

Bunting, S.C., B.M. Kilgore, and C.L. Bushey. 1987. Guidelines for Prescribe burning sagebrush-grass rangelands in the Northern Great Basin. General Technical Report INT-231. USDA Forest Service Intermountain Research Station, Ogden, UT. 33.

Colberg, T.J. and J.T. Romo. 2003. Clubmoss effects on plant water status and standing crop. *Journal of Range Management* 56:489–495.

Daubenmire, R. 1970. *Steppe vegetation of Washington*.

DiTomaso, J.M. 2000. Invasive weeds in Rangelands: Species, Impacts, and Management. *Weed Science* 48:255–265.

Dormaar, J.F., B.W. Adams, and W.D. Willms. 1997. Impacts of rotational grazing on mixed prairie soils and

- vegetation. *Journal of Range Management* 50:647–651.
- Hobbs, J.R. and S.E. Humphries. 1995. An integrated approach to the ecology and management of plant invasions. *Conservation Biology* 9:761–770.
- Kuchler, A.W. 1964. Potential natural vegetation of the conterminous United States.
- Lacey, J.R., C.B. Marlow, and J.R. Lane. 1989. Influence of Spotted knapweed (*Centaurea maculosa*) on surface runoff and sediment yield.. *Weed Technology* 3:627–630.
- Lesica, P. and S.V. Cooper. 1997. Presettlement vegetation of Southern Beaverhead County, MT.
- Manske, L.L. 1980. Habitat, phenology, and growth of selected sandhills range plants.
- Masters, R. and R. Sheley. 2001. Principles and practices for managing rangeland invasive plants. *Journal of Range Management* 38:21–26.
- McCalla, G.R., W.H. Blackburn, and L.B. Merrill. 1984. Effects of Livestock Grazing on Infiltration Rates of the Edwards Plateau of Texas. *Journal of Range Management* 37:265–269.
- McLean, A. and S. Wikeem. 1985. Influence of season and intensity of defoliation on bluebunch wheatgrass survival and vigor in southern British Columbia. *Journal of Range Management* 38:21–26.
- Miller, R.F., T.J. Svejcar, and J.A. Rose. 2000. Impacts of western juniper on plant community composition and structure. *Journal of Range Management* 53:574–585.
- Moulton, G.E. and T.W. Dunlay. 1988. *The Journals of the Lewis and Clark Expedition*. Pages in University of Nebraska Press.
- Mueggler, W.F. and W.L. Stewart. 1980. Grassland and Shrubland Habitat Types of Western Montana.
- Pelant, M., P. Shaver, D.A. Pyke, and J.E. Herrick. 2005. Interpreting Indicators of Rangeland Health.
- Pellant, M. and L. Reichert. 1984. Management and Rehabilitation of a burned winterfat community in Southwestern Idaho. Proceedings--Symposium on the biology of Atriplex and related Chenopods. 1983 May 2-6; Provo UT General Technical Report INT-172.. USDA Forest Service Intermountain Forest and Range Experiment Station. 281–285.
- Pitt, M.D. and B.M. Wikeem. 1990. Phenological patterns and adaptations in an *Artemisia/Agropyron* plant community. *Journal of Range Management* 43:350–357.
- Pokorny, M.L., R. Sheley, C.A. Zabinski, R. Engel, T.J. Svejcar, and J.J. Borkowski. 2005. Plant Functional Group Diversity as a Mechanism for Invasion Resistance.
- Wambolt, C. and G. Payne. 1986. An 18-Year Comparison of Control Methods for Wyoming Big Sagebrush in

West, N.E. 1994. Effects of Fire on Salt-Desert shrub rangelands. Proceedings--Ecology and Management of Annual Rangelands: 1992 May 18-22. Boise ID General Technical Report INT-GTR-313.. USDA Forest Service Intermountain Research Station. 71–74.

Whitford, W.G., E.F. Aldon, D.W. Freckman, Y. Steinberger, and L.W. Parker. 1989. Effects of Organic Amendments on Soil Biota on a Degraded Rangeland. Journal of Range Management 41:56–60.

Wilson, A.M., G.A. Harris, and D.H. Gates. 1966. Cumulative Effects of Clipping on Yield of Bluebunch wheatgrass. Journal of Range Management 19:90–91.

## Contributors

Petersen

## Approval

Kirt Walstad, 9/11/2023

## Rangeland health reference sheet

Interpreting Indicators of Rangeland Health is a qualitative assessment protocol used to determine ecosystem condition based on benchmark characteristics described in the Reference Sheet. A suite of 17 (or more) indicators are typically considered in an assessment. The ecological site(s) representative of an assessment location must be known prior to applying the protocol and must be verified based on soils and climate. Current plant community cannot be used to identify the ecological site.

Author(s)/participant(s)	Grant Petersen
Contact for lead author	grant.petersen@usda.gov
Date	03/01/2020
Approved by	Kirt Walstad
Approval date	
Composition (Indicators 10 and 12) based on	Annual Production

## Indicators

1. **Number and extent of rills:** Rills will primarily be absent on gentle slopes however on the steepest of slopes of this site (greater than 30 percent) small, short rills (less than 2-3 feet) may be evident after high precipitation events.

---

2. **Presence of water flow patterns:** Water flow patterns are rare in the reference condition. If present, they are most likely to occur on steeper slopes (greater than 20 percent) and are inconspicuous, disconnected, and very short in length.

---

3. **Number and height of erosional pedestals or terracettes:** Pedestals are not evident in the reference condition.

---



4. **Bare ground from Ecological Site Description or other studies (rock, litter, lichen, moss, plant canopy are not bare ground):** Bare ground is between 20-30 percent.
- 
5. **Number of gullies and erosion associated with gullies:** Gullies are not present in the reference condition.
- 
6. **Extent of wind scoured, blowouts and/or depositional areas:** Wind scoured, or depositional areas are not evident in the reference condition.
- 
7. **Amount of litter movement (describe size and distance expected to travel):** Movement of fine herbaceous litter may occur within less than a foot from where it originated.
- 
8. **Soil surface (top few mm) resistance to erosion (stability values are averages - most sites will show a range of values):** Soil Surface Stable with Stability Ratings of 4-6 (both under canopy and bare). Biotic crusts and/or root mats may be present.
- 
9. **Soil surface structure and SOM content (include type of structure and A-horizon color and thickness):** Structure trends to weak, fine granular. The A horizon is approximately 3 inches thick with wet Munsell colors Value 5 or less, Chroma 3 or less. Dry colors tend to be quite light prior to wetting. Official Series Description (OSD) for characteristic range.
- 
10. **Effect of community phase composition (relative proportion of different functional groups) and spatial distribution on infiltration and runoff:** Evenly distributed across the site, deep rooted bunchgrasses improve infiltration while rhizomatous grass protects the surface from runoff forces. The Shallow Droughty ecological site is well drained and has a moderately rapid infiltration rate. An even distribution across the site of approximately 50 to 60 percent (by weight) of mid-stature grasses, cool season rhizomatous grasses 10-15 percent along with a mix of shortgrass (5-10 percent), forbs (5-10 percent) and shrubs (10-15 percent). Trees and tall shrubs may occupy a trace of the plant community with less than 1 stem per acre.
- 
11. **Presence and thickness of compaction layer (usually none; describe soil profile features which may be mistaken for compaction on this site):** Not present
- 
12. **Functional/Structural Groups (list in order of descending dominance by above-ground annual-production or live foliar cover using symbols: >>, >, = to indicate much greater than, greater than, and equal to):**
- Dominant: Mid-statured, cool season, perennial bunchgrasses
- Sub-dominant: rhizomatous grasses = shrubs > perennial shortgrasses/grasslikes > forbs
- Other:
- Additional: Tall shrubs and trees may exist as a trace however absence does not affect Functional/Structural Group Dynamics.

---

13. **Amount of plant mortality and decadence (include which functional groups are expected to show mortality or decadence):** Mortality in herbaceous species is not evident. Species with bunch growth forms may have some natural mortality in centers.

---

14. **Average percent litter cover (%) and depth ( in):** Total litter cover ranges from 30-35%. Most litter is irregularly distributed on the soil surface and is not at a measurable depth.

---

15. **Expected annual annual-production (this is TOTAL above-ground annual-production, not just forage annual-production):** Average production: 1040 pounds per acre (lbs/acre) or 1166 kilograms per hectare (kg/ha)  
Low Production: 805 lbs/acre or 902 kg/ha  
High Production: 1260 lbs/acre or 1412 kg/ha

---

16. **Potential invasive (including noxious) species (native and non-native). List species which BOTH characterize degraded states and have the potential to become a dominant or co-dominant species on the ecological site if their future establishment and growth is not actively controlled by management interventions. Species that become dominant for only one to several years (e.g., short-term response to drought or wildfire) are not invasive plants. Note that unlike other indicators, we are describing what is NOT expected in the reference state for the ecological site:** Potential invasive (including noxious) species (native and non-native). Invasive species on this ecological site include (but not limited to) annual brome spp., spotted knapweed, yellow toadflax, leafy spurge, ventenata, crested wheatgrass, etc.

Native species such as Rocky Mountain juniper, ponderosa pine, Douglas fir, broom snakeweed, rabbitbrush spp., blue grama, Sandberg bluegrass, etc. when their populations are significant enough to affect ecological function, indicate site condition departure.

---

17. **Perennial plant reproductive capability:** In the reference condition, all plants are vigorous enough for reproduction either by seed or rhizomes in order to balance natural mortality with species recruitment. Density of plants indicates that plants reproduce at level sufficient to fill available resources.

---