

# Ecological site R046XC505MT Sandy (Sy) RRU 46-C 13-19 PZ

Last updated: 9/07/2023  
Accessed: 04/25/2024

---

## General information

**Provisional.** A provisional ecological site description has undergone quality control and quality assurance review. It contains a working state and transition model and enough information to identify the ecological site.

## MLRA notes

Major Land Resource Area (MLRA): 046X–Northern and Central Rocky Mountain Foothills

Major Land Resource Area (MLRA) 46, Rocky Mountain Foothills, is approximately 11.6 million acres. MLRA 46's extent has changed over recent years and is now primarily located in Montana and Wyoming with limited acres in Utah and Colorado. It spans from the Canadian border south to the Uinta Mountains of Northwest Colorado. MLRA 46 is a transitional MLRA between the plains and mountains of primarily non-forested rangeland. In Montana, 3 Land Resource Units (LRUs) exist based on differences in geology, landscape, soils, water resources, and plant communities. Elevations for this MLRA in Montana vary from a low of 3200 to 6500 feet (975 to 1981 m) however the elevations on the fringes of this MLRA may fall outside of that range in extremely small isolated areas where the boundaries between neighboring MLRAs are not easily defined. Annual precipitation ranges from 8 inches (254 mm) to, in very isolated areas, 42 inches (1083 mm). In general precipitation rarely exceeds 24 inches (610 mm). Frost-free days are variable from 50 days near the Crazy and Beartooth Mountains to 130 days in the foothills south of the Bear's Paw Mountains of Central Montana. The geology of MLRA 46 is generally Cretaceous and Jurassic marine sediments.

MLRA 46's plant communities are dominated by cool-season bunchgrasses with mixed shrubs. This MLRA is rarely forested; however, ponderosa and limber pine do occupy areas. Portions of this MRLA may have a subdominance of warm-season mid-statured bunchgrasses like little bluestem; however, the general concept of the MLRA does not have a large component of warm-season species. Wyoming big sagebrush, mountain big sagebrush, silver sagebrush, common snowberry, and shrubby cinquefoil tend to be the dominant shrub component. The kind and presences of shrubs tends to be driven by a combination of soils and climate. Due to the variable nature of the Land Resources Units, Climatic subsets will be necessary to describe the ecological sites and the variation of plant communities for this MLRA.

## LRU notes

LRU C is generally located in Central Montana. It borders the Little Belt Mountains, Highwood Mountains, Snowy Mountains (Big and Little), Crazy Mountains, and Castle Mountains. Included in this LRU are the foothills of the island mountain groups of the Bear's Paw and Little Rocky Mountains. This LRU borders MLRAs 43B, 52 and 58. LRU C is the second largest of the LRUs located in Montana occupying approximately 2.6 million acres. Cities and towns located in this LRU includes Stanford, Lewistown, Grass Range, and Harlowton. Elevation ranges from 2880 feet (878 m) to 6783 feet (2068 m).

The geology is sedimentary in nature with the majority including the Colorado Shale Formation, Kootenai Formation (mixed sedimentary), Mississippian Formation (carbonatic sedimentary), terrace deposits (alluvium), Tertiary mixed sedimentary. Areas of the Claggett Formation (mudstone), Devonian (carbonatic sedimentary) as well as intrusive and extrusive volcanics (mixed) exist in the foothills of the island mountains. Landforms include hillslopes, drainage ways, fan remnants, valleys, and escarpments.

This LRU is dominated by deep, well drained soils. Soil depth is mixed with 45 percent moderately-deep, 45 percent

very deep, and 10 percent other soil depth. Slopes are most frequently 0 to 15 percent and 15 to 30 percent, while higher sloping areas (30 to 45 percent) exist along the Little Belt and Highwood interfaces. Slightly acid to moderately alkaline soils throughout. Small areas of moderately acid soils exist in places, in particular around Highwoods. Vast differences in soil texture within LRU exist likely due to the variation in parent material.

The climate of this LRU is classic to the MLRA concept. The precipitation falls primarily as rain in the spring however areas may receive high amounts of snowfall (i.e. Lewistown). Precipitation ranges are from 13.7 inches (348 mm) to a rare 37.4 inches (942 mm) with 16 inches as an average. This LRU has an average air temperature of 44 degrees Fahrenheit (6.75 degrees C) with a range of 38 degrees Fahrenheit (3.38 degrees C) to 47.3 degrees Fahrenheit (8.52 degrees C). Frost-free days tends to be one of the longest of the Montana LRUs with a range of 70-130 days. Soil moisture regime is ustic with a frigid soil temperature regime. Due to the variability in climate of this LRU, climatic subsets will be necessary to accurately describe the ecological processes.

Major watersheds within this LRU include Big Spring Creek, Judith River, Swimming Woman Creek, and Musselshell River. These watersheds provide irrigation water for production of small grains and hay. As these watersheds leave the neighboring MLRA 43B, these river systems offer fishing and other recreational opportunities.

Cropland conversion is the largest land conversion within this LRU. Small grains such as wheat and barley are the most common particularly in Judith Basin County. Conversion to recreational property is becoming a more frequent occurrence, particularly near Lewistown.

### Ecological site concept

Site does not receive any additional water

- Soils are
  - Not saline or saline-sodic
  - Moderately deep, deep, or very deep
  - Typically less than 5 percent stone and boulder cover (less than 15 maximum)
  - Not Skeletal (less than 35 percent rock fragments) at 10-20 inch control section
  - Not strongly or violently effervescent within surface mineral 4 inches; calcium carbonate
- Soil surface texture ranges from coarse sandy loam to fine sandy loam in surface mineral 4 inches
- Argillic horizon, if present, does not have clay content greater than 20 percent percent.
- Parent material is alluvium

### Associated sites

R046XC508MT	<b>Silty (Si) RRU 46-C 13-19 PZ</b> Loamy ecological site occupies the same landscape position
-------------	---

### Similar sites

R046XC508MT	<b>Silty (Si) RRU 46-C 13-19 PZ</b> Loamy ecological site occupies the same landscape position. Shares similar plant community and state-and-transition model.
-------------	---

Table 1. Dominant plant species

Tree	Not specified
Shrub	(1) <i>Artemisia cana</i>
Herbaceous	(1) <i>Festuca campestris</i> (2) <i>Pseudoroegneria spicata</i>

### Physiographic features

The Sandy site exists on nearly level to gently sloping hills, flood plains, stream terraces, and alluvial fans. Slopes range from 2 to 20 percent slope but often less than 10 percent. Affects on aspect are not significant however slight variability may exist.

**Table 2. Representative physiographic features**

Landforms	(1) Foothills > Alluvial fan (2) Foothills > Hill (3) Foothills > Stream terrace (4) Foothills > Flood plain
Elevation	3,500–5,100 ft
Slope	1–20%
Aspect	Aspect is not a significant factor

## Climatic features

The climate of this LRU falls into Climatic Subset B. The central concept of Climatic Subset B is 13 to 19 inches Relative Effective Annual Precipitation (REAP) and 70 to 130 days frost-free. Calculated averages based on climate stations suggest that this Sandy ecological site receives just over 16 inches of precipitation with 60-104 Frost Free Days.

The soil temperature regime for this Sandy ecological site is frigid and the soil moisture regime is ustic

**Table 3. Representative climatic features**

Frost-free period (characteristic range)	35-87 days
Freeze-free period (characteristic range)	90-118 days
Precipitation total (characteristic range)	15-17 in
Frost-free period (actual range)	20-98 days
Freeze-free period (actual range)	70-130 days
Precipitation total (actual range)	13-19 in
Frost-free period (average)	60 days
Freeze-free period (average)	104 days
Precipitation total (average)	16 in

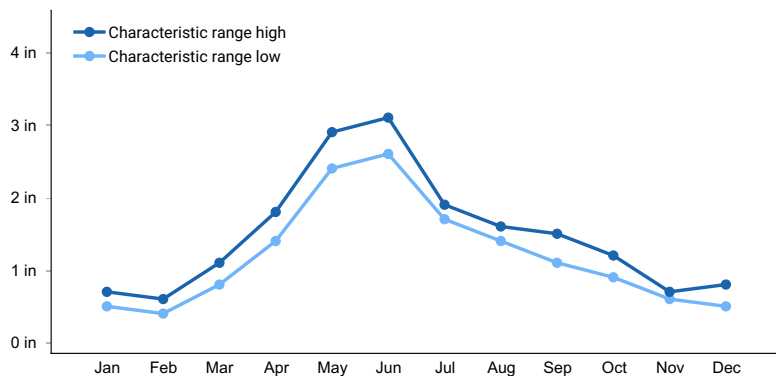

**Figure 1. Monthly precipitation range**

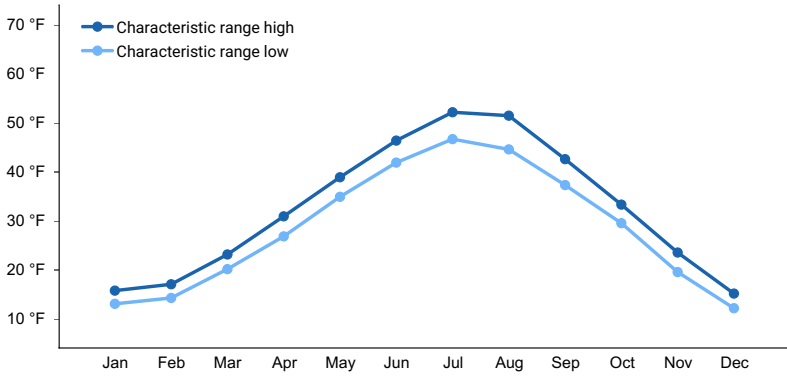

**Figure 2. Monthly minimum temperature range**

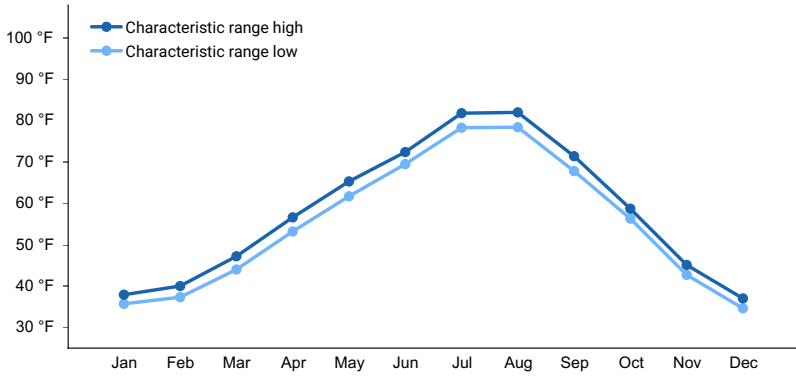

**Figure 3. Monthly maximum temperature range**

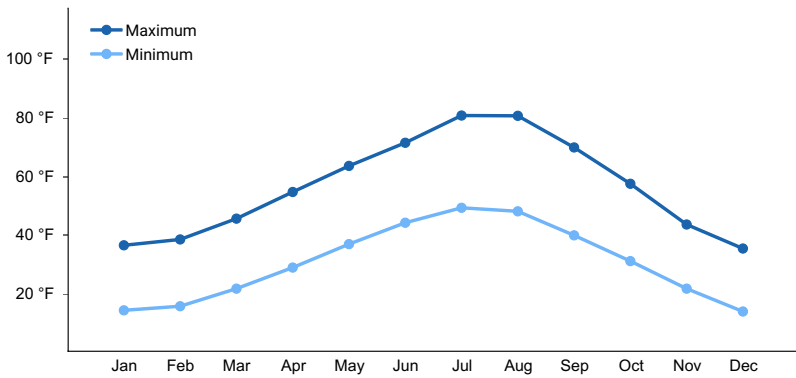

**Figure 4. Monthly average minimum and maximum temperature**

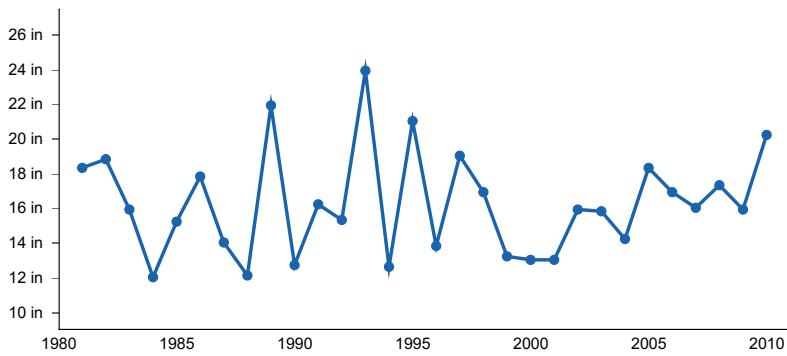

**Figure 5. Annual precipitation pattern**

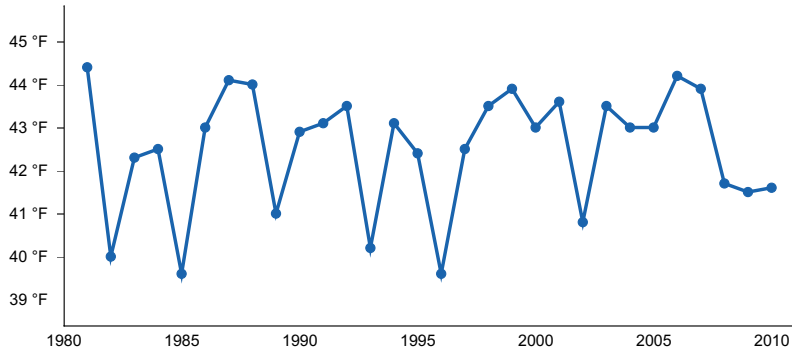

Figure 6. Annual average temperature pattern

### Climate stations used

- (1) RAYNESFORD 2 NNW [USC00246902], Raynesford, MT
- (2) STANFORD [USC00247864], Stanford, MT
- (3) CASCADE 20 SSE [USC00241557], Cascade, MT
- (4) GERALDINE [USC00243445], Geraldine, MT
- (5) LEWISTOWN MUNI AP [USW00024036], Lewistown, MT
- (6) HOBSON [USC00244193], Hobson, MT
- (7) JUDITH GAP 13 E [USC00244545], Judith Gap, MT
- (8) MARTINSDALE 3 NNW [USC00245387], Martinsdale, MT
- (9) LENNEP 5 SW [USC00244954], White Sulphur Springs, MT
- (10) MELVILLE 4 W [USC00245603], Big Timber, MT

### Influencing water features

Site is not associated with permanent water table however a seasonal water table deeper than 60 inches may exist.

### Wetland description

n/a

### Soil features

Soils of the Sandy Ecological Site are considered moderately deep to very deep with no root restrictive layer with the surface 20 inches. Surface textures are variable primarily consisting of coarse sandy loam to fine sandy loam. If present, an argillic horizon will have less than 20 percent clay. Common soil series in the ecological site include Chinook, Hoppers, Rhame, and Tally. These soils exist across a large landscape and due to natural variability may exist on multiple ecological sites. Use of the current ecological site key and on site soils pit are necessary to determine appropriate ecological site.

Parent material is primarily alluvium.

Table 4. Representative soil features

Parent material	(1) Alluvium–sedimentary rock
Surface texture	(1) Coarse sandy loam (2) Fine sandy loam (3) Sandy loam
Drainage class	Well drained
Permeability class	Moderate to rapid
Soil depth	40–100 in
Surface fragment cover <=3"	0–15%

Available water capacity (0-40in)	3.5–6.1 in
Clay content (0-5in)	10–24%

## Ecological dynamics

The Sandy (Sy) ecological site is characterized by the production and composition of the Reference Plant Community, which is defined by soils, precipitation, and the temperature regime influencing the site. In the Central Montan LRU of MLRA 46X, Subset B is found where an Ustic soil moisture regime occurs. This area is typified by a frigid soil temperature regime which receives a yearly representative value of 15 to 19 inches of relative effective annual precipitation and between 70 and 110 consecutive frost-free days annually. The Sandy ecological site is characterized by being not strongly or violently effervescent in the top 4 inches (10cm) of the soil surface, having coarse sandy loam to fine sandy loam surface textures, having less than 35 percent rock fragments in the 10 to 20 inch control section. If present, an argillic horizon will have less than 20 percent clay.

The majority of precipitation falls as rain from April through July. Primary growth typically occurs between May and early July. Dominant plants are those that have adapted to these conditions. The warmer, drier section of this LRU primary growth typically occurs between April and June. A period of fall “green-up” can occur among this cool season dominated plant community if adequate precipitation is present.

As the Sandy Ecological Site occurs across a relatively large landscape, slight variations within the plant community occur due to elevation, frost-free days, and relative effective annual precipitation. The reference plant community is heavily dominated by rough fescue (*Festuca campestris*), bluebunch wheatgrass (*Pseudoroegneria spicata*), prairie sandreed (*Calamagrostis longifolia*), and Idaho fescue (*Festuca idahoensis*). Subdominant species may include green needlegrass (*Nassella viridula*), muhly (*Muhlenbergia* spp), winterfat (*Krascheninnikovia lanata*), rabbitbrushes (*Ericameria* and *Chrysothamnus*), common snowberry (*Symphoricarpos albus*). This potential is suggested by investigations showing a predominance of perennial grasses on near-pristine range sites (Ross et al. 1973). In the reference plant community, shrubs are a relatively minor vegetative component.

A shift to dominance of shrubs may occur in response to improper grazing management or extended drought. Improper grazing management is typically defined as allowing multiple grazing events that take more than half of the current year's growth without allowing rest and recovery. Shrub encroachment by a variety of species, including, broom snakeweed (*Gutierrezia sarothrae*), fringed sagewort (*Artemisia frigida*), Sagebrushes (*Artemisia* ssp), rubber rabbitbrush (*Ericameria nauseosa*), yellow rabbitbrush (*Chrysothamnus viscidiflorus*) and plains prickly pear (*Opuntia polyacantha*) occur within this site as the mid-statured bunchgrasses decrease. Shrub dominance and grass loss can be associated with soil erosion and ultimately thinning of the native soil surface. Subsequent loss of soil could lead to a Degraded State.

Historical records indicate, prior to the introduction of livestock (cattle and sheep) during the late 1800's, elk and bison grazed this ecological site. Due to the nomadic nature and herd structure of bison, areas that were grazed received periodic high intensity short duration grazing pressure.

Natural fire as well as prescribed fire utilized by indigenous peoples was a major ecological driver of this entire ecological site. Fire tended to restrict tree and shrub growth to small patches and promoted an herbaceous plant community. The natural fire return interval was highly variable however it was likely shorter than 30 years. With the historically recent, since 1910, suppression of fire, shrubs and coniferous trees have increased significantly.

Due to relatively neutral to slightly alkaline pH of the soils on this site; the potential for farming is high. Hay and small grains production has constituted the largest replacement of native vegetation on this site with introduced cool-season annual crops (wheat, barley, oats), perennial introduced grass species and legumes (e.g., alfalfa) being best adapted. This ecological site has also been converted to pastureland usually perennial grasses and legumes for grazing. Cropland, pastureland, and hayland are intensively managed with annual cultivation, annual harvesting, and/or frequent use of herbicides, pesticides, and commercial fertilizers to increase production. Where irrigation water is available, this site is highly productive.

Dense clubmoss (*Selaginella densa*), in general, is a minor component of Reference plant community of the Sandy

Ecological Site. The conditions that created large cover classes of clubmoss on this site point to a history of continuous (yearlong) or moderate spring grazing use (Sturm 1954). The site could also be an old crop field that have reverted back to rangeland. In this case, clubmoss is helping reduce erosion and increase site stability especially where livestock use is restricted (such as CRP). While dense clubmoss provides soil stability on the sites it exists, a common misconception is that it competes for the limited water resources into the upper soil profile which restricts plant available water however a study from Canada (Colberg and Romo 2003) in a similar climate on similar soils indicates that the correlation between reduced plant available water and clubmoss cover is negligible. The correlation between reduced plant production may simply be competition for space though quantitative evidence is unavailable. Dense patches of clubmoss may, however, inhibit seed contact with soil reducing seedling recruitment.

Some of the major invasive species that can occur on this site include (but not limited to) spotted knapweed (*Centaurea stoebe*), leafy spurge (*Euphorbia esula*), Sulphur cinquefoil (*Potentilla recta*), cheatgrass (*Bromus tectorum*), field brome (*Bromus arevensis*), yellow toadflax (*Linaria vulgaris*), Dandelion (*Taraxicum spp*), and Kentucky bluegrass (*Poa pratensis*). Invasive weeds are beginning to have a high impact on this Ecological Site often as a result of human impacts such as mismanaged grazing, recreation, and urban development.

### Plant Communities and Transitions

A State and Transition Model for this Sandy ecological site is depicted below. Thorough descriptions of each state, transition, plant community, and pathway follow the model. This model is based on available experimental research, field data, field observations, and interpretations by experts. It is likely to change as knowledge increases.

The plant communities within the same ecological site will differ across the MLRA due to the naturally occurring variability in weather, soils, and aspect. The biological processes on this site are complex; therefore, representative values are presented in a land management context. The species lists are representative and are not full botanical descriptions of all species occurring, or potentially occurring, on this site. They are intended to cover the core species and known range of conditions and responses.

Both percent species composition by weight and percent canopy cover are referenced in this document. Canopy cover drives the transitions between communities and states because of the influence of shade, interception of rainfall and competition for available water. Species composition by dry weight remains an important descriptor of the herbaceous community and of the community as a whole. Woody species are included in species composition for the site. Calculating similarity index requires use of species composition by dry weight.

Although there is considerable qualitative experience supporting the pathways and transitions within the State and Transition Model (STM), no quantitative information exists that specifically identifies threshold parameters between grassland types and invaded types in this ecological site. For information on STMs, see the following citations: Bestelmeyer et al. 2003, Bestelmeyer et al. 2004, Bestelmeyer and Brown 2005, Stringham et al. 2003.

## State and transition model

**Ecosystem states**

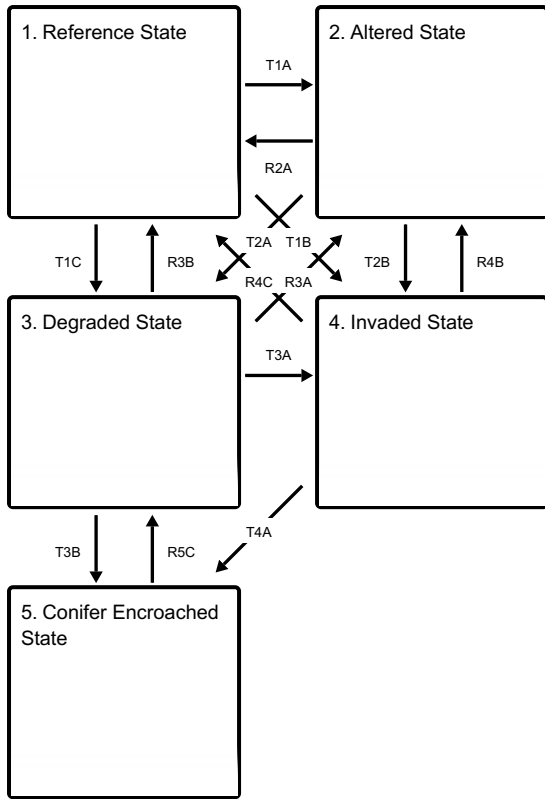

**States 1, 5 and 2 (additional transitions)**

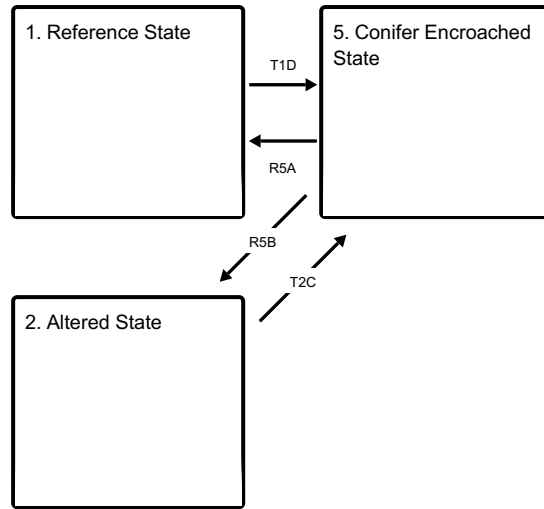

**State 1 submodel, plant communities**

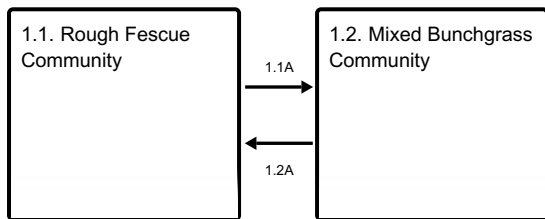

**State 2 submodel, plant communities**

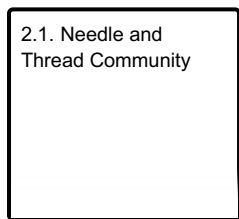

**State 3 submodel, plant communities**

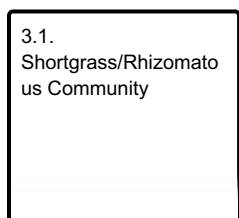

**State 4 submodel, plant communities**

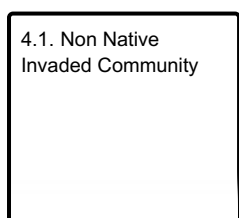



## State 5 submodel, plant communities

5.1. Conifer  
Community

## State 1 Reference State

The Reference State of this ecological site consists of 2 known potential plant communities 1.1 Rough Fescue Community and 1.2 Mixed Bluebunch Community. These are described below but are generally characterized by a mid-statured, cool season grass community with limited shrub production. Community 1.1 is dominated by rough fescue with bluebunch wheatgrass and is considered the reference while Community 1.2 has a codominance of rough fescue, bluebunch and needle-and-thread with an increase in green rabbitbrush and sagebrush.

### Community 1.1 Rough Fescue Community

In the Rough Fescue Plant Community, rough fescue, bluebunch wheatgrass (*Pseudoroegneria spicata*), green needlegrass (*Nassella viridula*), and needle-and-thread (*Hesperostipa comata*) are typically dominant. Indian ricegrass (*Achnatherum hymenoides*) and winterfat (*Krascheninnikovia lanata*) are subordinates in the community. Shrub species (silver sagebrush, fringed sagewort, broom snakeweed) remain a minor part of the community. In areas, Spineless horsebrush (*Tetradymia canescens*) may occupy a small niche though may not exist on others. Sandberg bluegrass (*Poa secunda*) and dryland sedges are also common. This state occurs on areas with proper livestock grazing or in areas with little or no grazing pressure. Bluebunch wheatgrass lacks resistance to grazing during the critical growing season (spring) and will decline in vigor and production if grazed in the critical growing season more than one year in three (Wilson et al. 1960). The Reference State is moderately resilient and will return to dynamic equilibrium following a relatively short period of stress (such as drought or short-term improper grazing), provided a return of favorable or normal growing conditions, and properly managed grazing. As discussed in the Ecological Dynamics section natural fire regime restricted shrubs to relatively small portions of the Reference Plant Community 1.1. Shrub species present may include silver sagebrush, spineless horsebrush, winterfat, tarragon (*Artemisia drucunculus*), and fringed sagewort. Infrequent fire probably maintained communities as open, seral stands of productive herbaceous species with patches of shrubs.

### Community 1.2 Mixed Bunchgrass Community

With proper grazing management over time, the Mixed Bunchgrass Community (1.2) can come close to the diversity and complexity of the Rough Fescue Community (1.1). Without active management the site is not likely to return to near Reference Plant Community. Western wheatgrass and needle-and-thread tolerate grazing pressure better than rough fescue and bluebunch wheatgrass. The growing point for rough fescue and bluebunch wheatgrass grass is several inches above the ground, making it very susceptible to continued close grazing (Smoliack, et al 2006) while western wheatgrass and needle-and-thread growing points tend to be near the plant base. These plants increase in composition when more palatable and less grazing tolerant plants decrease due to improper grazing management. Needle-and-thread, western wheatgrass, and bluebunch wheatgrass share dominance in the Mixed Bunchgrass Community (1.2). Other grass species, which are more tolerant to grazing and are likely to increase compared to the Reference Plant Community, include Sandberg bluegrass (*Poa secunda*), Prairie junegrass, and Thickspike wheatgrass (*Elymus lanceolatus*) and Blue grama (*Bouteloua gracilis*). Some increaser forbs species include Western yarrow, Hoods phlox (*Phlox hoodii*), Scarlet globemallow (*Sphaeralcea coccinea*), Hairy goldenaster (*Heterotheca villosa*), and pussytoes (*Antennaria* spp.). Fringed sagewort (*Artemisia frigid*) is a shrub that also increases under prolonged drought or heavy grazing and can respond to precipitation that falls in July and August. Heavy continuous grazing will reduce plant cover, litter, and mulch. Timing of grazing is important on this site because of the moisture limitations beyond June, especially on the drier sites. Bare ground will increase and expose the soil to erosion. Litter and mulch will be reduced as plant cover declines. As long as the production of bluebunch wheatgrass remains a significant portion of the total biomass production, the site can return to the

Bluebunch Wheatgrass Community (Pathway 1.2A) under proper grazing management and favorable growing conditions. The Mixed Bunchgrass Community (1.2) is the At-Risk Plant Community for this ecological site. When overgrazing continues increaser species such as needle-and-thread and native forb species will become more dominate and this triggers the change to the Altered Bunchgrass State (2) or the Degraded Shortgrass State (3). Until the Mixed Bunchgrass Community (1.2) crosses the threshold into the Needle-and-thread Community (2.1) or the Invaded Community (4.1), this community can be managed toward the Rough Fescue Community (1.1) using prescribed grazing and strategic weed control (if present). It may take several years to achieve this recovery, depending on growing conditions, vigor of remnant bluebunch wheatgrass plants, and the aggressiveness of the weed treatments.

### **Pathway 1.1A Community 1.1 to 1.2**

Rough fescue and bluebunch wheatgrass lose vigor with improper grazing or extended drought. When vigor declines enough for plants to die or become smaller, species with higher grazing tolerance increase in vigor and production as they access the resources previously used by rough fescue. Decrease of species composition by weight of rough fescue and to a lesser extent bluebunch wheatgrass indicates that the plant community has shifted to the Mixed Bunchgrass Community (1.2). The driver for community shift 1.1A is improper grazing management or prolonged drought. This shift is triggered by the loss of vigor of rough fescue and bluebunch wheatgrass, soil erosion or prolonged drought coupled with improper grazing. Blaisdell (1958) stated that drought and warmer than normal temperatures are known to advance plant phenology by as much as one month. During drought years, plants may be especially sensitive or in a critical stage of development earlier than expected. Since needle-and-thread normally heads out in June and rough fescue and bluebunch wheatgrass in July this should be taken into consideration when planning grazing management.

### **Pathway 1.2A Community 1.2 to 1.1**

The Mixed Bunchgrass Community (1.2) will return to the Rough Fescue Community (1.1) with proper grazing management and appropriate grazing intensity. Favorable moisture conditions will facilitate or accelerate this transition. It may take several years of favorable conditions for the community to transition back to a rough fescue dominated state. The driver for this community shift (1.2A) is increased vigor of rough fescue to the point that it represents more than 50% of species composition. The trigger for this shift is the change in grazing management favoring rough fescue. In general, conservative grazing management styles such as deferred or rest rotations utilizing moderate grazing (less than 50% use) coupled with favorable growing conditions like cool, wet springs are these triggers. These systems tend to promote increases in soil organic matter which promotes microfauna and can increase infiltration rates. Inversely, long periods of rest at a time when this state is considered to be stable may not result in an increase in rough fescue and it has been suggested (Noy-Meir 1975) that these long periods of rest or underutilization may actually drive the system to a lower level of stability by creating large amounts of standing biomass, dead plant caudex centers, and gaps in the plant canopy.

## **State 2 Altered State**

This state is characterized by having less than 15 percent rough fescue and bluebunch wheatgrass by dry weight. It is represented by 2 communities that differ in the percent composition of needle-and-thread, production, and soil degradation. Production in this state can be similar to the Reference State (1). Some native plants tend to increase under prolonged drought and/or heavy grazing practices. A few of these species may include needle-and-thread, Sandberg bluegrass, scarlet globemallow, hairy goldenaster, and fringed sagewort.

### **Community 2.1 Needle and Thread Community**

Long-term grazing mismanagement with continuous growing-season pressure will reduce total productivity of the site and lead to an increase of bare ground. Once plant cover is reduced, the site is more susceptible to erosion and degradation of soil properties. Soil erosion or reduced soil health will result in reduced plant production. This soil erosion or loss of soil fertility indicates the transition to the Altered State (2), because it creates a threshold requiring

input of energy to return to the Reference State (1). Transition to the Needle-and-thread Community (2.1) may be exacerbated by extended drought conditions. Needle-and-thread dominates this Community (2.1). Rough fescue and bluebunch wheatgrass makes up less than 10% of species composition by dry weight and the remaining bluebunch wheatgrass plants tend to be scattered and low in vigor. Increaser and invader species will be more common and create more competition for rough fescue and bluebunch wheatgrass. This makes it difficult for these species to quickly respond to a change in grazing management alone. Therefore, an input of energy is required for the community to return to the Reference State (1). Wind and water erosion may be eroding soil from the plant interspaces. Soil fertility is reduced and soil surface erosion resistance has declined compared to the Reference State (1). This community crossed a threshold compared to the Mixed Bunchgrass Community (1.2) due to the erosion of soil, vegetation composition, loss of soil fertility, or degradation of soil conditions. This results in a critical shift in the ecology of the site. The effects of soil erosion can alter the hydrology, soil chemistry, soil microorganisms, and soil structure to the point where intensive restoration is required to restore the site to another state or community. Changing grazing management alone cannot create sufficient improvement to restore the site within a reasonable time frame. Dormaar (1997) stated that with decreased grazing pressure a needle-and-thread/blue grama plant community did not change species composition but the content of the soil carbon increased. It will require a considerable input of energy to move the site back to the Reference State (1). This state has lost soil or vegetation attributes to the point that recovery to the Reference State (1) will require reclamation efforts, i.e., soil rebuilding, intensive mechanical treatments, and/or reseeding. The transition to this state could result from overgrazing, especially repeated early season grazing coupled with extensive drought. If heavy grazing continues, plant cover, litter, and mulch will continue to decrease and bare ground will increase exposing the soil to accelerated erosion. Litter and mulch will move off-site as plant cover declines. Continued improper grazing will drive the community to a Degraded State (3). Introduction or expansion of invasive species will further drive the plant community to the Invaded State (4).

### **State 3 Degraded State**

The Degraded State is described by a single plant community consisting of nearly equal components of increaser grasses, shrubs, and forbs. Large patches of bare ground exist with areas of erosional pedestalling and terracettes common. Dense clubmoss (*Selaginella densa*) exists between plant bases as a reaction to the increased bare ground

#### **Community 3.1 Shortgrass/Rhizomatous Community**

Soil loss continues or increases with grass and forb cover becoming very sparse or clumped (canopy cover <30%). Weeds, annual species, cacti, or shrubs dominate the plant community. Mid-stature perennial bunchgrass species (e.g., needle-and-thread) may exist, but only in small patches. This could occur due to overgrazing (failure to adjust stocking rate to declining forage production due to increased invasive dominance), long-term lack of fire (if Wyoming Big Sagebrush occurs), or introduction of invasive species. In the most severe stages of degradation, there is a significant amount of bare ground, and large gaps occur between plants. Large patches of prickly pear cactus are common. Potential exists for soils to erode to the point that irreversible damage may occur. This is a critical shift in the ecology of the site. Soil erosion combined with lack of organic matter deposition due to sparse vegetation create changes to the hydrology, soil chemistry, soil microorganisms, and soil structure to the point where intensive restoration is required to restore the site to another state or community. Changing management (i.e., improving grazing management) cannot create sufficient change to restore the site within a reasonable time frame. This state is characterized by soil surface degradation and little plant soil surface cover. Shrub canopy cover is usually greater than 15%. In this plant community, big sagebrush is replaced with a dominant community of broom snakeweed, rabbitbrush, fringed sagewort, and plains pricklypear cactus. This state has lost soil or vegetation attributes to the point that recovery to the Bunchgrass Grassland State will require reclamation efforts, i.e. soil rebuilding, intensive mechanical treatments, and/or reseeding. This plant community may be in a terminal state that will not return to the reference state because of degraded soil conditions and loss of higher successional native plant species. Key factors of approach to transition: Decrease in grass canopy cover and production, increase of shrub canopy cover, increases in mean bare patch size, increases in soil crusting, decreases in cover of cryptobiotic crusts, decreases in soil aggregate stability, and/or evidence of erosion including water flow patterns and litter movement.

## **State 4 Invaded State**

The Invaded State is identified by being in the exponential growth phase of invader abundance where control is a priority. Dominance (or relative dominance) of noxious/invasive species reduces species diversity, forage production, wildlife habitat, and site protection. A level of 20% invasive species composition by dry weight indicates the point that a substantial energy input will be required to create a shift to the grassland state (herbicide, mechanical treatment) even with a return to proper grazing management or favorable growing conditions. Prescriptive grazing can be used to manage invasive species. In some instances, carefully targeted grazing (sometimes in combination with other treatments) can reduce or maintain species composition of invasive species. These communities within this state will follow a pathway if the invasive/noxious species will continue to thrive without mechanical, biological, or chemical control methods to exceed 50% of species composition by dry weight. The invasive nature of the weed out-competes the present plant community. Once the weed reaches maximum population level for this site, effective control is unlikely without massive resource inputs. Ecological processes of the site may change after invading species have established and spread (Walker and Smith 1997).

### **Community 4.1 Non Native Invaded Community**

Communities in this state may be structurally indistinguishable from the bunchgrass state except that invasive/noxious species exceed 20% of species composition by dry weight. This state may also include a community similar to the Degraded State (3) except that invasive/noxious species exceed 20% of species composition by dry weight. Although there is no research to document the level of 20%, this is estimated to be the point in the invasion process following the lag phase based on interpretation of Masters and Sheley 2001. For aggressive invasive species (i.e., spotted knapweed) a 20% threshold could be less than 10 percent. Early in the invasion process there is a lag phase where the invasive plant populations remain small and localized for long periods before expanding exponentially (Hobbs and Humphries 1995). Production in the invaded community may vary greatly. A site dominated by Kentucky bluegrass or spotted knapweed, where soil fertility and chemistry remain near reference, may have production near that of the reference community. A site with degraded soils and an infestation of cheatgrass may produce only 10 to 20 percent of the reference community. Once invasive species dominate the site, either in species composition by weight or in their impact on the community the threshold has been crossed to the Invaded State (4). As invasive species such as spotted knapweed, cheatgrass, and leafy spurge become established, they become very difficult to eradicate. Therefore considerable effort should be placed in preventing plant communities from crossing a threshold to the Invaded State (4) through early detection and proper management. Preventing new invasions is by far the most cost-effective control strategy, and typically places an emphasis on education. Control measures used on the noxious plant species impacting this ecological site include chemical, biological, and cultural control methods. The best success has been found with an integrated pest management (IPM) strategy that incorporates one or several of these options along with education and prevention efforts (DiTomaso 2000).

## **State 5 Conifer Encroached State**

The Conifer Encroached State is still being researched however it may contain as many as 4 different communities.

### **Community 5.1 Conifer Community**

Rocky Mountain juniper (*Juniperus scopulorum*), Ponderosa pine (*Pinus ponderosa*), limber pine (*Pinus flexilis*), and Douglas fir (*Pseudotsuga menziesii*) encroachment is common on this ecological site and is generally focused in areas where the mountains of MLRA 43B transition quickly to MLRA 46. Under the Reference State, no conifers should exist on this site. It is also noted that all states may transition to the Conifer Encroached State however encroachment is most likely to occur in the the Altered State (see State-and-transition model) where there is an increase of bare ground due to a combination of factors that allows seed-to-soil contact with reduced competition. Fire suppression and improper grazing management are the two most common triggers. The exact mode in which conifers begin to encroach varies however the trend points to a combination of 1 or more of the following: repeated moderately heavy to heavy grazing, reduced (non-existent) fire frequency, increased

atmospheric carbon, and generally warmer climate (compared to that of pre-settlement). When heavy grazing occurs areas in the plant canopy open allowing for seed dispersal by bird or overland flow via rills on neighboring sites. The effects of conifer encroachment are not immediately noticed however over time as conifer canopy increases; light and water interception increase which reduce opportunities for herbaceous plants. One paper (Barrett, 2007) suggests that for precipitation to penetrate the juniper canopy, events must be greater than 0.30 inches. Increase tree canopy creates perching sites for predators which reduces site suitability for greater sage grouse. More information is needed on the full extent and impact of juniper encroachment on this plant communities for an approved Ecological Site Description. Studies (Miller et al 2000) based in a similar to the Rocky Mountain Juniper community of Montana suggest following a phased approach to characterize the juniper stand. Not unlike the Western Juniper community discussed in Miller et al, the Rocky Mountain juniper communities of Montana exhibit 3 or 4 different phases based, at this time, on qualitative assumptions. Phase I (Early) is defined by actively expanding juniper cover with generally <10% canopy cover and the trees' limbs generally touch the ground. This early stage generally has not completely lost its hydrologic functions however herbaceous plant communities may show signs of reduced production and species richness. Control methods include mechanical removal and prescribed fire. Prescribed fire is still effective in this phase as it still contains the necessary native plants for recovery. The tree canopy is also low enough that risk of a dangerously hot fire is reduced. Phase II (Mid Stage) is still actively expanding however canopy cover may reach up to 15-25% and due to the more mature trees seed production is very high. This Mid Phase begins to highly restrict herbaceous and shrubby plant and junipers tend to be codominant. Hydrology is departing from reference with rills becoming longer and in isolated areas erosional gullies may exist. Control methods of the Mid Stage should focus on mechanical treatment as there is a high risk of catastrophic and potentially sterilizing fire. Phase III (Late stage) is where juniper cover exceed 25% and has slowed as a forest condition. Lower limbs of trees begin to die and the shrub cover is nearly lost. Traveling through this community is increasingly difficult. Junipers become the dominant plant with herbaceous plant production greatly decreased. Bare ground increases and hydrologic function is nearly lost compared to a grass/shrub community. Late Stage Phase should focus more on restoration than control as the necessary plants will likely not be present to cross the threshold back to a rangeland situation. The soil stability and hydrologic function are lacking in this phase so mechanical removal of juniper will be necessary. Phase IV (Closed) is the steady state forest where the system is nearly absent of rangeland plants. The trees stop producing seed and begin to close in on each other. This phase is impassible and nearly all light and precipitation are intercepted. Bare ground is high and soil chemistry slowly changes due to acidification from juniper. Within this LRU, the closed phase is extremely rare due to 2 reasons: 1) this phase takes upwards of 100 years to occur 2) management often occurs before trees are allowed to reach this phase. The presence of sagebrush stumps indicates the historical plant community as rangeland which will prevent misclassification of historic Juniper Forests (often >100 years of age).

### **Transition T1A** **State 1 to 2**

The Reference State (1) transitions to the Altered State (2) if rough fescue and bluebunch wheatgrass, by dry weight, decreases to below 10% or if bare ground cover is increased beyond 20%. The driver for this transition is loss of taller bunchgrasses, which creates open areas in the plant canopy with bare soil. Soil erosion results in decreased soil fertility, driving transitions to the Altered State. There are several other key factors signaling the approach of transition T1A: increases in soil physical crusting, decreases in cover of cryptogamic crusts, decreases in soil surface aggregate stability and/or evidence of erosion including water flow patterns, development of plant pedestals, and litter movement. The trigger for this transition is improper grazing management and/or long-term drought leading to a decrease in rough fescue and bluebunch wheatgrass composition to <10% and reduction in total plant canopy cover.

### **Transition T1C** **State 1 to 3**

The Reference State (1) transitions to the Degraded State (3) when rough fescue and bluebunch wheatgrass are almost completely removed from the plant community and Needle-and-thread is subdominant to short statured bunchgrasses such as Sandberg bluegrass. This transition differs from T1A in that it is generally a rapid transition and usually associated with disturbances such as repeated overgrazing or heavy human traffic. This rapid transition is generally realized where livestock are confined to small pastures for long periods of time such as horse pastures and calving lots. The driver for this transition is loss of taller bunchgrasses, which creates openings in the canopy exposing bare soil. Soil erosion results in decreased soil health, driving transitions to the Degraded State. There are several other key factors signaling the approach of transition T1C: increases in soil physical crusting, decreases in

cover of cryptogamic crusts, decreases in soil surface aggregate stability and/or evidence of erosion including water flow patterns, development of plant pedestals, and litter movement. The trigger for this transition is improper grazing management, long term drought, and/or heavy human disturbance.

### **Transition T1B**

#### **State 1 to 4**

Healthy plant communities are most resistant to invasion however, regardless of grazing management, without some form of active weed management (chemical, mechanical, or biological control) and prevention the Reference State (1) can transition to the Invaded State (4) in the presence of aggressive invasive species such as spotted knapweed, leafy spurge, and cheatgrass. This will occur even if the reference community is thriving. The Rocky Mountain Foothills tend to resist invasion of cheatgrass however repeated heavy grazing or intense human activities can open the interspaces of the bunchgrass community and allow for encroachment. Long-term stress conditions for native species (e.g., overgrazing, drought, and fire) accelerate this transition. If populations of invasive species reach critical levels, the site transitions to the Invaded State. The trigger for this transition is the presence of aggressive invasive species. Species composition by dry weight of invasive species approaches 10%.

### **Transition T1D**

#### **State 1 to 5**

1% canopy cover of coniferous tree/shrub cover. The trigger is the presence of seeds and/or other viable material of invasive species.

### **Restoration pathway R2A**

#### **State 2 to 1**

The Altered State (2) has lost soil or vegetation attributes to the point that recovery to the Reference State (1) will require reclamation efforts such as soil rebuilding, intensive mechanical and cultural treatments, and/or revegetation. Low intensity prescribed fires to reduce competitive increaser plants such as Needle-and-thread and Sandberg bluegrass. A low intensity fire will also reduce shrub densities. In areas with potential of annual grass infestation, fire should be carefully planned or avoided

### **Transition T2A**

#### **State 2 to 3**

As improper grazing management continues vigor of bunch grasses will decrease, and the shorter grasses and shrubs will increase towards the Degraded State (3). Prolonged drought will provide a competitive advantage to shrubs allowing them to become co-dominant with grasses. Shrub canopy will increase above 15% canopy cover. Key transition factors: increase of native shrub canopy cover; reduction in bunchgrass production; decrease in total plant canopy cover and production; increases in mean bare patch size; increases in soil crusting; decreases in cover of cryptobiotic crusts; decreases in soil aggregate stability; and/or evidence of erosion including water flow patterns and litter movement.

### **Transition T2B**

#### **State 2 to 4**

Invasive species can occupy the Altered State (2) and drive it to the Invaded State (4). The Altered State is at risk if invasive seeds and/or other viable material are present. The driver for this transition is more than 10% dry weight of invasive species.

### **Transition T2C**

#### **State 2 to 5**

1% canopy cover of coniferous tree/shrub cover. The trigger is the presence of seeds and/or other viable material of invasive species.

## **Restoration pathway R3B**

### **State 3 to 1**

The Degraded State (3) has lost soil or vegetation attributes to the point that recovery to the Reference State (1) will require reclamation efforts, such as soil rebuilding, intensive mechanical treatments, and/or revegetation. Studies suggest (Whitford et al 1989) a mulch with high carbon to nitrogen ratio such as wood chips or bark in low moisture scenarios can be beneficial for slow mobilization of plant available nitrogen. Biochar may also be added to the system to improve Soil Organic Carbon (SOC) which should improve Cation Exchange Capacity (CEC), microbial activity, and hydrologic conductivity (Stavi 2012). The drivers for the restoration pathway are removal of increaser species, restoration of native bunchgrass species, persistent management of invasives and shrubs, and proper grazing management. Without continued control, invasive and shrub species are likely to return (probably rapidly) due to presence of seeds and/or other viable material in the soil and management related increases soil disturbance.

## **Restoration pathway R3A**

### **State 3 to 2**

Since the bunchgrass plant community has been significantly reduced, restoration to the Altered State (2) is unlikely unless a seed source is available. However, if a sufficient amount of grass remains on the site, chemical application and/or biological control in conjunction with proper grazing management, can reduce the amount of shrubs and invasive species and restore the site. Low intensity fire can be utilized to reduce shrubs competition and allow the reestablishment of grass species. Caution must be used when considering fire as a management tool on sites with fire tolerant shrubs such as rubber rabbitbrush, as these shrubs will re-sprout after a burn. Broom snakeweed and fringed sagewort may or may not re-sprout depending on conditions (USDA Forest Service 2011).

## **Transition T3A**

### **State 3 to 4**

Invasive species can occupy the Degraded State (3) and drive it to the Invaded State (4). The Degraded State is at risk of this transition occurring if invasive seeds or viable material are present. The driver for this transition is presence of critical population levels (more than 10% dry weight of invasive species). The trigger is the presence of seeds or viable material of invasive species. This state has sufficient bare ground that the transition could occur simply due to presence or introduction of invasive seeds or viable material. This is particularly true of aggressive invasive species such as spotted knapweed. This transition could be assisted by overgrazing (failure to adjust stocking rate to declining forage production), long-term lack of fire, or extensive drought.

## **Transition T3B**

### **State 3 to 5**

1% canopy cover of coniferous tree/shrub cover. The trigger is the presence of seeds and/or other viable material of invasive species.

## **Restoration pathway R4C**

### **State 4 to 1**

Restoration of the Invaded State (4) to the Reference State (1) requires substantial energy input. The drivers for the restoration pathway are removal of invasive species, restoration of native bunchgrass species, persistent management of invasive species, and proper grazing management. Without continued control, invasive species are likely to return (probably rapidly) due to the presence of seeds and/or other viable material in the soil and management related practices that increase soil disturbance. Sites that have transitioned from the Degraded State (3) to the Invaded State (4) may be severely lacking soil and vegetative properties that will allow for restoration to the Reference State. Hydrologic function damage may be irreversible especially with accelerated gully erosion.

## **Restoration pathway R4B**

### **State 4 to 2**

If invasive species are removed before remnant populations of bunchgrasses have been drastically reduced the

Invaded State (4) can return to the Altered State. The driver for the reclamation pathway is weed management without reseeding or removal of conifer (mechanical, cultural, chemical depending on the Phase of the community). Continued Integrated Pest Management (IPM) will be required as many of the invasive species that can occupy the Invaded State have extended dormant seed life.

### **Transition T4A State 4 to 5**

1% canopy cover of coniferous tree/shrub cover. The trigger is the presence of seeds and/or other viable material of invasive species.

### **Restoration pathway R5A State 5 to 1**

Depending on the level of conifer canopy cover and its impact on rangeland health, restoration efforts may be simply focus on removal of coniferous trees and shrubs to restore the Conifer Encroached State (5) to the Reference State (1). If following utilizing the phases established by Miller et al management and restoration methods will vary. An large majority of the conifer encroachment in MLRA 46 will fall into the early two phases of Miller's Phases. Phase I may exhibit None-Slight to Moderate departures from rangeland health where removal of the conifers via Brush Management and/or Prescribed fire combined. If mechanical removal of conifers is utilized, no grazing management is needed assuming relatively conservative management had been used prior to treatment. If prescribed fire is utilized, short term grazing deferment and/or rest is suggested. Given a short time removal of a Phase I encroachment will recover to Reference. Proactive pest management is encouraged. Phase II Encroachment may require a more intense mechanical removal of trees/shrubs with Prescribed Fire not being a feasible method of control as this community may be at risk of catastrophic fire due to canopy density. Phase II displays a Moderate departure from Reference suggesting an overall instability of the site such as reduced herbaceous production, reduced functional/structural groups (e.g. reduced mid-statured bunchgrasses), increase rill frequency and length, and possibly increased bare ground. Increased post treatment grazing management may be necessary. Grazing management may be as simple as short term growing season deferment however long term rest may be necessary in the latter stages of Phase II encroachment. Latter stages of Phase II encroachment will likely require some short term erosion mitigation such as straw waddles as well as range planting and/or critical area planting to re-establish any loss of native herbaceous plants particularly mid-statured cool season bunchgrasses. Phase III Encroachment canopy cover resembles forested sites with larger trees and shrubs. Forest management style tree removal (woody debris and logs removed from the site) will be necessary prior to any prescribed burning as to prevent the fire from burning too hot. The result of a prescribed fire on this site are typically unknown as seed sources of native herbaceous plants are usually limited to small patches. Since this is a dry site, herbaceous plants will likely have been depleted under a Phase III encroachment. This means there is an opportunity for large areas of bare ground, increase rill and in some cases gully erosion. Post treatment will require range planting and/or critical area seeding, erosion control, pest management, and possibly soil carbon amendments (biochar). Grazing management (primarily rest) will be necessary to ensure any new seedling establishment.

### **Restoration pathway R5B State 5 to 2**

Depending on the level of conifer canopy cover and its impact on rangeland health, restoration efforts may be simply focus on removal of coniferous trees and shrubs to restore the Conifer Encroached State (5) to the Altered State (2). If following utilizing the phases established by Miller et al management and restoration methods will vary. An large majority of the conifer encroachment in MLRA 46 will fall into the early two phases of Miller's Phases. Phase I may exhibit None-Slight to Moderate departures from rangeland health where removal of the conifers via Brush Management and/or Prescribed fire combined. If mechanical removal of conifers is utilized, no grazing management is needed assuming relatively conservative management had been used prior to treatment. If prescribed fire is utilized, short term grazing deferment and/or rest is suggested. Given a short time removal of a Phase I encroachment will recover to Reference. Proactive pest management is encouraged. Phase II Encroachment may require a more intense mechanical removal of trees/shrubs with Prescribed Fire not being a feasible method of control as this community may be at risk of catastrophic fire due to canopy density. Phase II displays a Moderate departure from Reference suggesting an overall instability of the site such as reduced



herbaceous production, reduced functional/structural groups (e.g. reduced mid-statured bunchgrasses), increase rill frequency and length, and possibly increased bare ground. Increased post treatment grazing management may be necessary. Grazing management may be as simple as short term growing season deferment however long term rest may be necessary in the latter stages of Phase II encroachment. Latter stages of Phase II encroachment will likely require some short term erosion mitigation such as straw wattles as well as range planting and/or critical area planting to re-establish any loss of native herbaceous plants particularly mid-statured cool season bunchgrasses. Phase III Encroachment canopy cover resembles forested sites with larger trees and shrubs. Forest management style tree removal (woody debris and logs removed from the site) will be necessary prior to any prescribed burning as to prevent the fire from burning too hot. The result of a prescribed fire on this site are typically unknown as seed sources of native herbaceous plants are usually limited to small patches. Since this is a dry site, herbaceous plants will likely have been depleted under a Phase III encroachment. This means there is an opportunity for large areas of bare ground, increase rill and in some cases gully erosion. Post treatment will require range planting and/or critical area seeding, erosion control, pest management, and possibly soil carbon amendments (biochar). Grazing management (primarily rest) will be necessary to ensure any new seedling establishment.

## **Restoration pathway R5C**

### **State 5 to 3**

Depending on the level of conifer canopy cover and its impact on rangeland health, restoration efforts may be simply focus on removal of coniferous trees and shrubs to restore the Conifer Encroached State (5) to the Degraded State (3). If following utilizing the phases established by Miller et al management and restoration methods will vary. An large majority of the conifer encroachment in MLRA 46 will fall into the early two phases of Miller's Phases. Phase I may exhibit None-Slight to Moderate departures from rangeland health where removal of the conifers via Brush Management and/or Prescribed fire combined. If mechanical removal of conifers is utilized, no grazing management is needed assuming relatively conservative management had been used prior to treatment. If prescribed fire is utilized, short term grazing deferment and/or rest is suggested. Given a short time removal of a Phase I encroachment will recover to Reference. Proactive pest management is encouraged. Phase II Encroachment may require a more intense mechanical removal of trees/shrubs with Prescribed Fire not being a feasible method of control as this community may be at risk of catastrophic fire due to canopy density. Phase II displays a Moderate departure from Reference suggesting an overall instability of the site such as reduced herbaceous production, reduced functional/structural groups (e.g. reduced mid-statured bunchgrasses), increase rill frequency and length, and possibly increased bare ground. Increased post treatment grazing management may be necessary. Grazing management may be as simple as short term growing season deferment however long term rest may be necessary in the latter stages of Phase II encroachment. Latter stages of Phase II encroachment will likely require some short term erosion mitigation such as straw wattles as well as range planting and/or critical area planting to re-establish any loss of native herbaceous plants particularly mid-statured cool season bunchgrasses. Phase III Encroachment canopy cover resembles forested sites with larger trees and shrubs. Forest management style tree removal (woody debris and logs removed from the site) will be necessary prior to any prescribed burning as to prevent the fire from burning too hot. The result of a prescribed fire on this site are typically unknown as seed sources of native herbaceous plants are usually limited to small patches. Since this is a dry site, herbaceous plants will likely have been depleted under a Phase III encroachment. This means there is an opportunity for large areas of bare ground, increase rill and in some cases gully erosion. Post treatment will require range planting and/or critical area seeding, erosion control, pest management, and possibly soil carbon amendments (biochar). Grazing management (primarily rest) will be necessary to ensure any new seedling establishment.

## **Additional community tables**

### **Animal community**

The Sandy Ecological site of the Rocky Mountains Foothills provides for a variety of wildlife habitat for an array of species. Prior to the settlement of this area, large herds of antelope, elk and bison roamed. Though the bison have been replaced, mostly with domesticated livestock, elk and antelope still frequently utilize this largely intact landscape for winter habitat in areas adjacent to forest.

The relatively high grass component of the Reference Community provides excellent nesting cover for multiple neotropical migratory birds that select for open grasslands such as the Long-billed Curlew and McCown's Longspur.

Managed livestock grazing is suitable on this site due to the potential to produce an abundance of high quality forage. This is often a preferred site for grazing by livestock, and animals tend to congregate in these areas. In order to maintain the productivity of the Sandy site, grazing on adjoining sites with less production must be managed carefully to be sure utilization on this site is not excessive. Management objectives should include maintenance or improvement of the native plant community. Careful management of timing and duration of grazing is important. Shorter grazing periods and adequate deferment during the growing season are recommended for plant maintenance, health, and recovery. According to McLean et al, early season defoliation of rough fescue and bluebunch wheatgrass can result in high mortality and reduced vigor of plants. They also suggest, based on prior studies, that the opportunity for regrowth is necessary before dormancy to reduce injury rough fescue and bluebunch wheatgrass./

Since needle-and-thread normally matures earlier than rough fescue and bluebunch wheatgrass as well as produces a sharp awn this species is usually avoided after seed set. Changing grazing season of use will help utilize needle-and-thread more efficiently.

Continual non-prescribed grazing of this site will be injurious, will alter the plant composition and production over time, and will result in transition to the Altered State. Transition to other states will depend on duration of poorly managed grazing as well as other circumstances such as weather conditions and fire frequency.

The Altered State is subject to further degradation to the Degraded State or Invaded State. Management should focus on grazing management strategies that will prevent further degradation, such as seasonal grazing deferment or winter grazing where feasible. Communities within this state are still stable and healthy under proper management. Forage quantity and/or quality may be substantially decreased from the Reference State.

Grazing is possible in the Invaded State. Invasive species are generally less palatable than native grasses. Forage production is typically greatly reduced in this state. Due to the aggressive nature of invasive species, sites in the Invaded State face increased risk for further degradation to the Invasive Communities. Grazing has to be carefully managed to avoid further soil loss and degradation and possible livestock health issues.

Prescriptive grazing can be used to manage invasive species. In some instances, carefully targeted grazing (sometimes in combination with other treatments) can reduce or maintain species composition of invasive species. In the Degraded State, grazing may be possible but is generally not economically and/or environmentally sustainable.

## **Hydrological functions**

The hydrologic cycle functions best in the Reference State (1) with good infiltration and deep percolation of rainfall; however, the cycle degrades as the vegetation community declines. Rapid rainfall infiltration, high soil organic matter, good soil structure, and good porosity accompany high bunchgrass canopy cover. High ground cover reduces rain drop impact on the soil surface, which keeps erosion and sedimentation transport low. Water leaving the site will have minimal sediment load, which allows for high water quality in associated streams. High rates of infiltration will allow water to move below the rooting zone during periods of heavy rainfall. The Rough Fescue Community (1.1) should have no rills or gullies present and drainage ways should be vegetated and stable. Water flow patterns, if present, will be barely observable. Plant pedestals are essentially non-existent. Plant litter remains in place and is not moved by wind or water.

Improper grazing management results in a community shift to the Mixed Bunchgrass Community (1.2). This plant community has a similar canopy cover, but bare ground will be less than 15%. Therefore, the hydrologic cycle is functioning at a level similar to the water cycle in the Rough Fescue (1.1). Compared to the Rough Fescue Community (1.1) infiltration rates are slightly reduced and surface runoff is slightly higher.

In the Altered State (2), Degraded State (3) and the Invaded State (4) canopy and ground cover are greatly reduced compared to the Reference State (1), which impedes the hydrologic cycle. Infiltration will decrease and runoff will increase due to reduced ground cover, presence of shallow-rooted species, rainfall splash, soil capping, reduced organic matter, and poor structure. Sparse ground cover and decreased infiltration can combine to increase frequency and severity of flooding within a watershed. Soil erosion is accelerated, quality of surface runoff is poor, and sedimentation increases.

Hydrology of the Conifer Encroached State (5) is highly variable however studies suggest that increased tree canopy affects interception of rainfall and well as reduces available soil moisture for herbaceous vegetation. This can negatively affect infiltration and increase runoff.

## **Recreational uses**

This site provides some limited recreational opportunities for hiking, horseback riding, big game and upland bird hunting. The forbs have flowers that appeal to photographers. This site provides valuable open space.

## **Inventory data references**

Information presented was derived from NRCS inventory data, National Resources Inventory (NRI) data, literature, field observations, and personal contacts with range-trained personnel (i.e., used professional opinion of agency specialists, observations of land managers, and outside scientists).

## **Other references**

McLean, A. and S. Wikeem. 1985. Influence of season and intensity of defoliation on bluebunch wheatgrass survival and vigor in southern British Columbia. *Journal of Range Management* 38:21–26.

Ross, R.L., E.P. Murray, and J.G. Haigh. July 1973. Soil and Vegetation of Near-pristine sites in Montana.

Colberg, T.J. and J.T. Romo. 2003. Clubmoss effects on plant water status and standing crop. *Journal of Range Management* 56:489–495.

Walker, L.R. and S.D. Smith. 1997. Impacts of invasive plants on community and ecosystem properties. Pages 69–86 in *Assessment and management of plant invasions*. Springer, New York, NY.

Barrett, H. 2007. *Western Juniper Management: A Field Guide*.

Miller, R.F., T.J. Svejcar, and J.A. Rose. 2000. Impacts of western juniper on plant community composition and structure. *Journal of Range Management* 53:574–585.

Masters, R. and R. Sheley. 2001. Principles and practices for managing rangeland invasive plants. *Journal of Range Management* 38:21–26.

Hobbs, J.R. and S.E. Humphries. 1995. An integrated approach to the ecology and management of plant invasions. *Conservation Biology* 9:761–770.

DiTomaso, J.M. 2000. Invasive weeds in Rangelands: Species, Impacts, and Management. *Weed Science* 48:255–265.

Dormaer, J.F., B.W. Adams, and W.D. Willms. 1997. Impacts of rotational grazing on mixed prairie soils and vegetation. *Journal of Range Management* 50:647–651.

Smoliak, S., R.L. Ditterlin, J.D. Scheetz, L.K. Holzworth, J.R. Sims, L.E. Wiesner, D.E. Baldrige, and G.L. Tibke. 2006. *Montana Interagency Plant Materials Handbook*.

Wilson, A.M., G.A. Harris, and D.H. Gates. 1966. Cumulative Effects of Clipping on Yield of Bluebunch wheatgrass. *Journal of Range Management* 19:90–91.

Blaisdell, J.P. 1958. Seasonal development and yield of native plants on the Upper Snake River Plains and their relation to certain climate factors.

Whitford, W.G., E.F. Aldon, D.W. Freckman, Y. Steinberger, and L.W. Parker. 1989. Effects of Organic Amendments on Soil Biota on a Degraded Rangeland. *Journal of Range Management* 41:56–60.

Stavi, I. 2012. The potential use of biochar in reclaiming degraded rangelands. *Journal of Environmental Planning and Management* 55:1–9.

Bestelmeyer, B., J.R. Brown, J.E. Herrick, D.A. Trujillo, and K.M. Havstad. 2004. Land Management in the American Southwest: a state-and-transition approach to ecosystem complexity. *Environmental Management* 34:38–51.

Bestelmeyer, B. and J. Brown. 2005. State-and-Transition Models 101: A Fresh look at vegetation change.

Stringham, T.K., W.C. Kreuger, and P.L. Shaver. 2003. State and Transition Modeling: an ecological process approach. *Journal of Range Management* 56:106–113.

Stringham, T.K. and W.C. Krueger. 2001. States, Transitions, and Thresholds: Further refinement for rangeland applications.

Stavi, I 2012. The potential use of biochar in reclaiming degraded rangelands. *Journal of Environmental Planning and Management* 55:1-9

Humphrey, L. David. 1984. Patterns and mechanisms of plant succession after fire on Artemisia-grass sites in southeastern Idaho *Vegetation*. 57: 91-101.

Tirmenstein, D. 1999. *Gutierrezia sarothrae*. In: Fire Effects Information System, [Online]. U.S. Department of Agriculture, Forest Service, Rocky Mountain Research Station, Fire Sciences Laboratory (Producer). <https://www.fs.fed.us/database/feis/plants/shrub/gutsar/all.html> [2022, March 30].

## Contributors

Grant Petersen

## Approval

Kirt Walstad, 9/07/2023

## Rangeland health reference sheet

Interpreting Indicators of Rangeland Health is a qualitative assessment protocol used to determine ecosystem condition based on benchmark characteristics described in the Reference Sheet. A suite of 17 (or more) indicators are typically considered in an assessment. The ecological site(s) representative of an assessment location must be known prior to applying the protocol and must be verified based on soils and climate. Current plant community cannot be used to identify the ecological site.

Author(s)/participant(s)	Grant Petersen
Contact for lead author	grant.petersen@usda.gov
Date	03/01/2020
Approved by	Kirt Walstad
Approval date	
Composition (Indicators 10 and 12) based on	Annual Production

## Indicators

1. **Number and extent of rills:** Rills are not present in the reference condition.
-

2. **Presence of water flow patterns:** Water flow patterns are not present in the reference condition.

---
3. **Number and height of erosional pedestals or terracettes:** Pedestals are not evident in the reference condition.

---
4. **Bare ground from Ecological Site Description or other studies (rock, litter, lichen, moss, plant canopy are not bare ground):** Bare ground is less than 5%. It consists of small, randomly scattered patches.

---
5. **Number of gullies and erosion associated with gullies:** Gullies are not present in the reference condition.

---
6. **Extent of wind scoured, blowouts and/or depositional areas:** Wind scoured, or depositional areas are not evident in the reference condition.

---
7. **Amount of litter movement (describe size and distance expected to travel):** Litter movement is not evident in the reference condition.

---
8. **Soil surface (top few mm) resistance to erosion (stability values are averages - most sites will show a range of values):** The average soil stability rating is 4-6 under plant canopies and 3-5 in canopy interspaces. The A horizon is 6-8 inches thick.

---
9. **Soil surface structure and SOM content (include type of structure and A-horizon color and thickness):** Soil Structure at the surface is typically moderate to strong fine granular. A Horizon should be 6-8 inches thick with color, when wet, typically ranging in Value of 3 or less and Chroma of 3 or less. Local geology may affect color, it is important to reference the Official Series Description (OSD) for characteristic range. <https://soilseries.sc.egov.usda.gov/osdname.aspx>

---
10. **Effect of community phase composition (relative proportion of different functional groups) and spatial distribution on infiltration and runoff:** Infiltration of the Sandy ecological site is moderate to moderately rapid. This site is well drained. An even distribution of deep-rooted mid-stature grasses (40-45%), cool season shortgrasses (10-15%) along with warm season shortgrass (5-10%), rhizomatous grass (35-45%), forbs (10-15%), and shrubs (1-5%) efficiently maximizes infiltration and reduces runoff.

---
11. **Presence and thickness of compaction layer (usually none; describe soil profile features which may be mistaken for compaction on this site):** A compaction layer is not present in the reference condition.

---
12. **Functional/Structural Groups (list in order of descending dominance by above-ground annual-production or live foliar cover using symbols: >>, >, = to indicate much greater than, greater than, and equal to):**

Dominant: Mid-statured, cool season, perennial bunchgrasses (bluebunch wheatgrass, rough fescue) ≥ warm season, rhizomatous grasses (prairie sandreed)

Sub-dominant: cool season, shortgrasses/grasslikes (needlethread, Junegrass) = forbs > cool season, rhizomatous grasses = warm season bunchgrasses >> Shrubs

Other:

Additional:

---

13. **Amount of plant mortality and decadence (include which functional groups are expected to show mortality or decadence):** Mortality in herbaceous species is not evident. Species with bunch growth forms may have some natural mortality in centers is 3% or less.
- 

14. **Average percent litter cover (%) and depth ( in):** Total litter cover ranges from 60 to 65%. Most litter is irregularly distributed on the soil surface and is not at a measurable depth.
- 

15. **Expected annual annual-production (this is TOTAL above-ground annual-production, not just forage annual-production):** Average annual production is 2000. Low: 1600 High 2400. Production varies based on effective precipitation and natural variability of soil properties for this ecological site.
- 

16. **Potential invasive (including noxious) species (native and non-native). List species which BOTH characterize degraded states and have the potential to become a dominant or co-dominant species on the ecological site if their future establishment and growth is not actively controlled by management interventions. Species that become dominant for only one to several years (e.g., short-term response to drought or wildfire) are not invasive plants. Note that unlike other indicators, we are describing what is NOT expected in the reference state for the ecological site:** Potential invasive (including noxious) species (native and non-native). Invasive species on this ecological site include (but not limited to) sulphur cinquefoil, houndstounge, annual brome spp., spotted knapweed, toadflax, leafy spurge, crested wheatgrass, Kentucky bluegrass, pale alyssum, ventenata

Native species such as Rocky Mountain juniper, ponderosa pine, Douglas fir, lupine, broom snakeweed, Sandberg's bluegrass, dense clubmoss, yucca, etc. when their populations are significant enough to affect ecological function, indicate site condition departure.

---

17. **Perennial plant reproductive capability:** In the reference condition, all plants are vigorous enough for reproduction either by seed or rhizomes in order to balance natural mortality with species recruitment.
-