

## Ecological site R047XA010UT Interzonal Wet Fresh Streambank (willow)

Last updated: 2/05/2025  
Accessed: 02/26/2025

### General information

**Provisional.** A provisional ecological site description has undergone quality control and quality assurance review. It contains a working state and transition model and enough information to identify the ecological site.

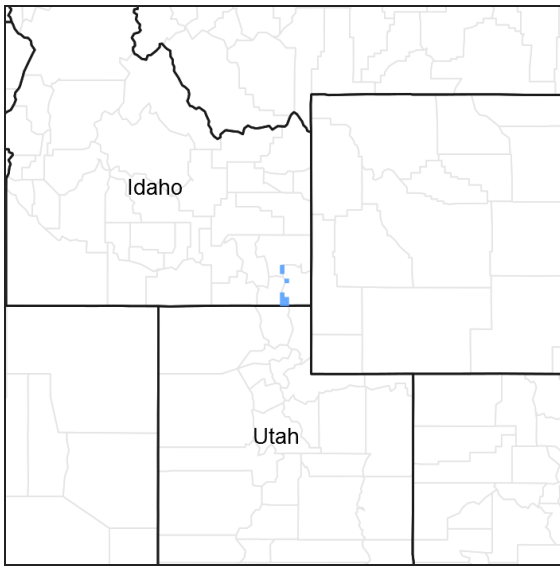

Figure 1. Mapped extent

Areas shown in blue indicate the maximum mapped extent of this ecological site. Other ecological sites likely occur within the highlighted areas. It is also possible for this ecological site to occur outside of highlighted areas if detailed soil survey has not been completed or recently updated.

### MLRA notes

Major Land Resource Area (MLRA): 047X–Wasatch and Uinta Mountains

MLRA 47 occurs in Utah (86 percent), Wyoming (8 percent), Colorado (4 percent), and Idaho (2 percent). It encompasses approximately 23,825 square miles (61,740 square kilometers). The northern half of this area is in the Middle Rocky Mountains Province of the Rocky Mountain System. Parts of the western edge of this MLRA are in the Great Basin Section of the Basin and Range Province of the Intermontane Plateaus. The MLRA includes the Wasatch Mountains, which trend north and south. The steeply sloping, precipitous Wasatch Mountains have narrow crests and deep valleys. Active faulting and erosion are a dominant force in controlling the geomorphology of the area.

The mountains in this area are primarily fault blocks that have been tilted up. Alluvial fans at the base of the mountains are recharge zones for the basin fill aquifers. An ancient shoreline of historic Bonneville Lake is evident on the footslopes along the western edge of the area. Rocks exposed in the mountains are mostly Mesozoic and Paleozoic sediments.

The average precipitation is from 12 to 16 inches in the valleys and can range up to 73 inches in the mountains. Peak precipitation occurs in the winter months. The average annual temperature is 30 to 50 degrees Fahrenheit (-1 to 15 C). The freeze-free period averages 140 days and ranges from 60 to 220 days, generally decreasing in length with elevation.

The dominant soil orders in this MLRA are Entisols, Inceptisols, and Mollisols. The lower elevations are dominated by a frigid temperature regime, while the higher elevations experience cryic temperature regimes. The soil moisture

regime is typically xeric. The mineralogy is generally mixed and the soils are very shallow to very deep, generally well drained, and loamy or loamy-skeletal.

## LRU notes

This LRU includes the Wasatch Mountains which tend to run north and south. These steeply sloping, precipitous mountains have narrow crests and deep valleys. They are primarily fault blocks that have been tilted up. The alluvial fans located at the base of these mountains are important recharge zones for valley aquifers.

## Ecological site concept

This site occurs on flood plains and stream terraces that often occur in mountain valleys. It is found on gently sloping terrain near perennial streams. The water table is typically 0 to 15 inches below the soil surface during May and June, and is accessible to most plant roots throughout the growing season. Flooding may occur on the site, but ponding is not typical.

The soils of this site are deep and poorly drained. They formed in alluvium derived from limestone, sandstone, shale and quartzite. Surface textures are silty clay, silt loam to loam. Rock fragments may be present on the soil surface and throughout the profile, but make up less than 35 percent of the soil volume. Water holding capacity in the upper 40 inches of soil ranges from 3.0 to 9.0 inches. Soil moisture regime is aquic and soil temperature regime can be frigid to cryic.

## Associated sites

R047XA004UT	<b>Interzonal Cold Semi-wet Fresh Meadow (meadow sedge/tufted hairgrass)</b>
R047XA008UT	<b>Interzonal Wet Fresh Meadow (sedge)</b>
R047XA006UT	<b>Semi-wet Fresh Streambank (narrowleaf cottonwood)</b>

## Similar sites

R047XA006UT	<b>Semi-wet Fresh Streambank (narrowleaf cottonwood)</b>
R047XA008UT	<b>Interzonal Wet Fresh Meadow (sedge)</b>

**Table 1. Dominant plant species**

Tree	Not specified
Shrub	(1) <i>Salix</i>
Herbaceous	(1) <i>Carex aquatilis</i> (2) <i>Elymus glaucus</i>

## Physiographic features

This site occurs on flood plains and stream terraces that often occur in mountain valleys. It is found on gently sloping terrain near perennial streams. The water table is typically 0 to 15 inches below the soil surface during May and June, and is accessible to most plant roots throughout the growing season. Flooding may occur on the site, but ponding is not typical.

**Table 2. Representative physiographic features**

Landforms	(1) Flood plain (2) Mountain valley
Runoff class	High to very high
Flooding duration	Long (7 to 30 days) to very long (more than 30 days)
Flooding frequency	None to frequent
Ponding frequency	None

Elevation	6,000–8,300 ft
Slope	0–3%
Water table depth	0–15 in
Aspect	Aspect is not a significant factor

**Table 3. Representative physiographic features (actual ranges)**

Runoff class	Low to very high
Flooding duration	Not specified
Flooding frequency	Not specified
Ponding frequency	Not specified
Elevation	Not specified
Slope	Not specified
Water table depth	Not specified

### Climatic features

The climate of this site characterized by cold, snowy winters and cool summers. The average annual precipitation ranges from 18 to 25 inches. March thru May and August, are typically the wettest months with June and July being the driest. The most reliable sources of moisture for plant growth are the snow that accumulates over the winter, and spring rains. Summer thunderstorms are intermittent and sporadic in nature, and thus, are less reliable sources of moisture to support vegetative growth on this site.

**Table 4. Representative climatic features**

Frost-free period (characteristic range)	80-100 days
Freeze-free period (characteristic range)	
Precipitation total (characteristic range)	18-25 in
Frost-free period (average)	
Freeze-free period (average)	
Precipitation total (average)	22 in

### Influencing water features

The water table is typically 0 to 15 inches below the soil surface during May and June, and is accessible to most plant roots throughout the growing season. Flooding may occur on the site, but ponding is not typical.

### Wetland description

Further review is required.

### Soil features

The soils of this site are deep and poorly drained. They formed in alluvium derived from limestone, sandstone, shale and quartzite. Surface textures are silty clay, silt loam to loam. Rock fragments may be present on the soil surface and throughout the profile, but make up less than 50 percent of the soil volume. Water holding capacity in the upper 40 inches of soil ranges from 3.0 to 9.0 inches. Soil moisture regime is aquic and soil temperature regime can be frigid to cryic.

**Table 5. Representative soil features**

Parent material	(1) Alluvium–sedimentary rock
Surface texture	(1) Silty clay loam (2) Silt loam (3) Loam
Family particle size	(1) Fine-loamy
Drainage class	Poorly drained to very poorly drained
Permeability class	Moderately slow
Surface fragment cover <=3"	0–1%
Available water capacity (0-40in)	3–9 in
Calcium carbonate equivalent (0-40in)	0%
Electrical conductivity (0-40in)	0–1 mmhos/cm
Sodium adsorption ratio (0-40in)	0–1
Soil reaction (1:1 water) (0-40in)	6.6–7.3
Subsurface fragment volume <=3" (Depth not specified)	17–49%
Subsurface fragment volume >3" (Depth not specified)	2–15%

## Ecological dynamics

It is impossible to determine in any quantitative detail the Historic Climax Plant Community (HCPC) for this ecological site because of the lack of direct historical documentation preceding all human influence. In the 1860s, Europeans brought cattle and horses to the area, grazing large numbers of them on unfenced parcels year-long.

Below is a State and Transition Model diagram to illustrate the “phases” (common plant communities), and “states” (aggregations of those plant communities) that can occur on the site. Differences between phases and states depend primarily upon observations of a range of disturbance histories in areas where this ESD is represented. These situations include grazing gradients to water sources, fence-line contrasts, patches with differing dates of fire, herbicide treatment, tillage, etc. Reference State 1 illustrates the common plant communities that probably existed just prior to European settlement.

The major successional pathways within states, (“community pathways”) are indicated by arrows between phases. “Transitions” are indicated by arrows between states. The drivers of these changes are indicated in codes decipherable by referring to the legend at the bottom of the page and by reading the detailed narratives that follow the diagram. The transition between Reference State 1 and State 2 is considered irreversible because of the naturalization of exotic species of both flora and fauna, possible extinction of native species, and climate change. There may have also been accelerated soil erosion.

When available, monitoring data (of various types) were employed to validate more subjective inferences made in this diagram. See the complete files in the office of the State Range Conservationist for more details.

## State and transition model

# R047AY010UT: Interzonal – Wet Fresh Streambank (Willow spp.)

---

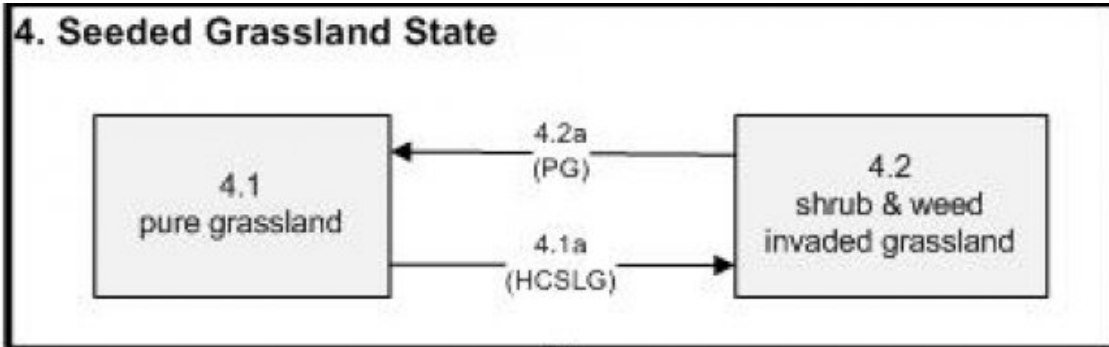

T3a  
(Till; RS)

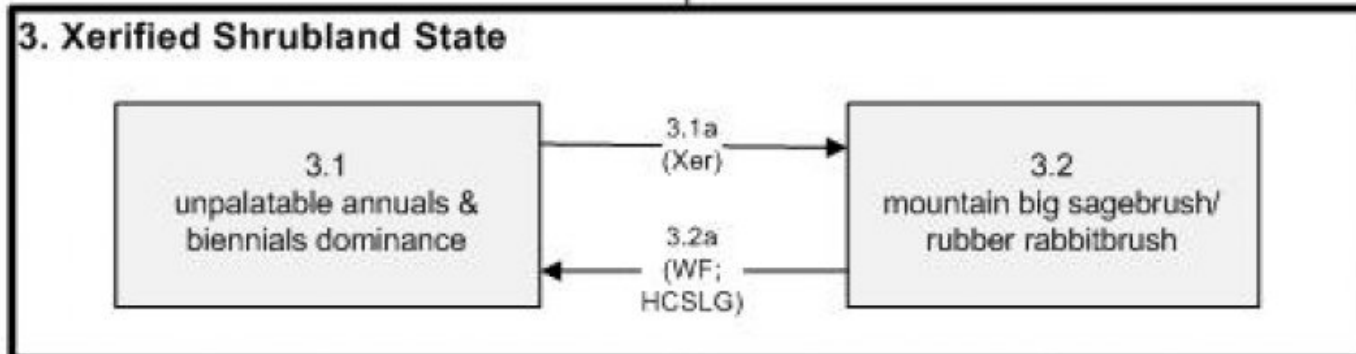

T2a  
(HCSLG;  
SE;  
Ch)

R3a  
(BDB&P)

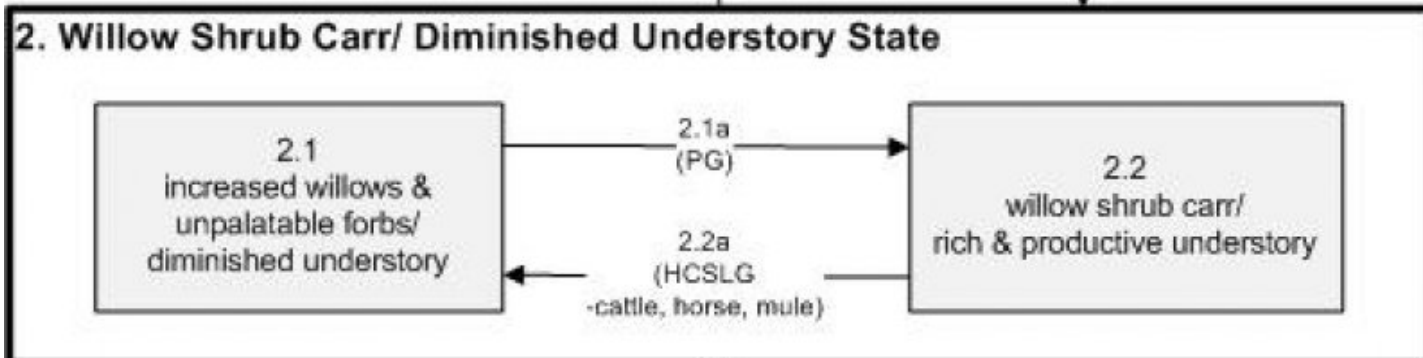

T1a  
(HC;  
HCSLG)

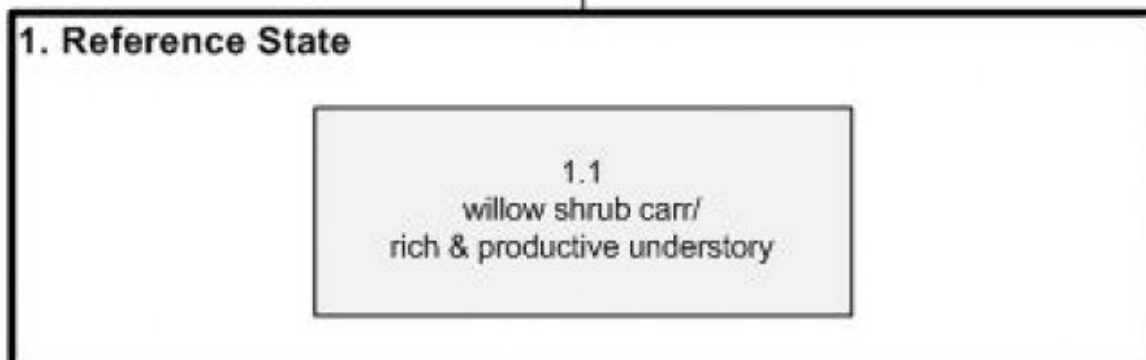

BDB&P	Beaver Dam Building & Ponding
Ch	Channelization (down-cutting)
HC	Historic Change
HCSLG	Heavy Continuous Season Long Grazing
PG	Prescribed Grazing
RS	Re-seeding
SE	Soil Erosion
Till	Tillage
WF	Wildfire
Xer	Xerification

Figure 2. State and Transition Model

## State 1 Reference State

The Reference State is a description of this ecological site prior to Euro-American settlement but long after the arrival of Native Americans. The description of the Reference State was determined by NRCS Soil Survey Type Site Location information and familiarity with rangeland relict areas where they exist. The least modified plant community (1.1) within the Reference State would have been a carr (i.e. tall shrub-dominated wetland) dominated by willows (Booth's willow (*Salix boothii*), shortfruit willow (*Salix brachycarpa*), Drummond's willow (*Salix drummondiana*), Geyer willow (*Salix geyeriana*), grayleaf willow (*Salix glauca*), Bebb willow (*Salix bebbiana*), Pacific willow (*Salix lucida* ssp. *lasiandra*), yellow willow (*Salix lutea*), and/or Scouler's willow (*Salix scouleriana*)), species depending on geographic region. This list of willow species may be different than those listed in the "Plant Community Composition by Weight and Percentage" section of this document because these species are identified in higher elevations (Montane and Sub-alpine zones) only. Dominant grasses would have included tufted hairgrass (*Deschampsia cespitosa*), blue wildrye (*Elymus glaucus*), and mountain brome (*Bromus marginatus*), and the grass-like water sedge (*Carex aquatilis*). Associated forbs would have included common cowparsnip (*Heracleum maximum*), field horsetail (*Equisetum arvense*), and feathery false lily of the valley (*Maianthemum racemosum*). Englemann spruce (*Picea engelmannii*) and blue spruce (*Picea pungens*) would have also occurred sparingly as small trees. Tree species present indicated where this phase was located topographically.

## Community 1.1 Willow shrub carr/ rich & productive understory

Without disturbance, the Reference State would have been dominated by woody plants. The proportion of woody plants in relation to herbaceous understory species would have been influenced by the time and type of natural disturbance that most recently took place. Possible natural disturbances would have included beaver and moose consumption of willow, deciduous wood pathogens (i.e. insects) reducing particular species, wildfires, and extreme run-off causing flooding or diversion of existing drainages. Such disturbances would have temporarily decreased the woody component and allowed an increase in herbs. All of these influences tended to have very long return intervals. Without such disturbance, woody plants would have increased at the expense of the understory because of the overtopping shade they create.

Table 6. Annual production by plant type

Plant Type	Low (Lb/Acre)	Representative Value (Lb/Acre)	High (Lb/Acre)
Grass/Grasslike	1170	1512	2070
Shrub/Vine	478	630	863
Forb	23	378	518
<b>Total</b>	<b>1671</b>	<b>2520</b>	<b>3451</b>

Table 7. Ground cover

Tree foliar cover	49-51%
Shrub/vine/liana foliar cover	19-21%
Grass/grasslike foliar cover	19-21%

Forb foliar cover	4-6%
Non-vascular plants	0%
Biological crusts	0%
Litter	0%
Surface fragments >0.25" and <=3"	0%
Surface fragments >3"	0%
Bedrock	0%
Water	0%
Bare ground	0%

**Table 8. Canopy structure (% cover)**

Height Above Ground (Ft)	Tree	Shrub/Vine	Grass/ Grasslike	Forb
<0.5	–	–	–	–
>0.5 <= 1	–	–	–	4-6%
>1 <= 2	–	–	19-21%	–
>2 <= 4.5	–	–	–	–
>4.5 <= 13	–	19-21%	–	–
>13 <= 40	–	–	–	–
>40 <= 80	49-51%	–	–	–
>80 <= 120	–	–	–	–
>120	–	–	–	–

## State 2

### Willow Shrub Carr/ Diminished Understory State

State 2 is very similar to State 1 in form and function, with the exception of the presence of non-native plants and animals, possible extinctions of native species, and a different climate. State 2 is a description of the ecological site shortly following Euro-American settlement. This state can be regarded as the current potential. State 2 can fluctuate between two willow-dominated phases: one that is relatively undisturbed with a rich and productive understory (2.2), and another where the understory is reduced due to the heavy livestock grazing (2.1). Phase 2.1 is a willow (*Salix* spp.) stand with a reduced understory due to the heavy livestock grazing. This Phase was also produced by horses and mules belonging to early European settlers and travelers (2.2a). These areas usually have surface water available, an attractant to most animals in the vicinity, which tend to pass through these stands at least once daily to feed, get water, and find shade. Heavy use of this part of the landscape was common until the creation of the Forest Reserves and U.S. Forest Service, when forest managers began to require users to be more sensitive of these areas. When the U.S. Forest Service began regulating use of their lands, including areas occupied by this ESD (circa 1910), the number of livestock and their season of use was reduced drastically, salt was placed only on upland locations, and sheep camps were required to be moved often. Because of the high resilience of these sub-irrigated habitats, partial recovery of the understory was attained in many instances and accelerated soil erosion arrested. Sustainable use was approached in such instances (2.1a).

### Community 2.1

#### Increased willows & unpalatable forbs/ diminished understory

Periods of heavy livestock and trail stock grazing of the herbaceous understory, along with near-extirpation of beaver and moose, causes this plant community to experience an increase in the proportion of woody plants at the expense of the herbaceous understory. Sedges, unpalatable forbs, and woody species are increased.

### Community 2.2

## **Willow shrub carr/ rich & productive understory**

This plant community has regained the understory components following a period of reduction in livestock use.

### **Pathway 2.1a**

#### **Community 2.1 to 2.2**

A reduction in livestock numbers and limiting seasons of use allows the understory component to rejuvenate.

### **Pathway 2.2a**

#### **Community 2.2 to 2.1**

Heavy continuous season-long grazing by livestock reduces the palatable understory species. This occurred in the past when these sites were common places for travelers to feed and water their animals.

## **State 3**

### **Xerified Shrubland State**

Where control of grazing intensity isn't been achieved earlier and excessive use by livestock prevails, the vegetation takes on more of the character of that of drier sites at low elevations. As the water table is lowered, the stature of the willows and other riparian shrubs declines, allowing upland species such as rubber rabbitbrush (*Ericameria nauseosus*), mountain big sagebrush (*Artemisia tridentata* ssp. *vaseyana*), and snowfield sagebrush (*Artemisia spiciformis*) to fill in these sites (3.2). Wildfire followed by continued heavy livestock grazing (3.2a) will temporarily remove the shrub and palatable herbaceous component, leaving annuals and biennials such as lesser burdock (*Arctium minus*), rough cocklebur (*Xanthium strumarium*), horehound (*Marrubium vulgare*), houndstongue (*Cynoglossum officinale*), stickseed (*Hackelia* spp.), Canada thistle (*Cirsium arvense*), and Scotch cottonthistle (*Onopordum acanthium*) to flourish (3.1). The recovery of moose and beaver puts more pressure on the remaining willows. However, if enough willow and other deciduous shrubs survive previous herbivory to allow beaver dam building, and thus re-ponding of these sites (R3a), it may be possible for the original mesic species to re-establish and for the site to return to State 2. A return to heavy livestock grazing will negatively impact the resiliency of this State.

### **Community 3.1**

#### **Unpalatable annuals & biennials dominance**

This plant community is dominated by assorted unpalatable annuals and biennials that gained dominance following wildfire and heavy continuous season-long grazing. Some of the species may include burdock, cocklebur, horehound, houndstongue, stickseed, Canada thistle, and Scotch cotton thistle.

### **Community 3.2**

#### **Mountain big sagebrush/ rubber rabbitbrush**

This plant community is dominated by mountain big sagebrush and rubber rabbitbrush due to a lowering of the water table and subsequent xerification of the site.

### **Pathway 3.1a**

#### **Community 3.1 to 3.2**

Previous channelization and consequent lowering of the water table will over time lead to xerification of this site. This occurs because channelization moves water through the site rather than allowing it to infiltrate the soil and be retained for season-long plant growth.

### **Pathway 3.2a**

#### **Community 3.2 to 3.1**

In the event of wildfire followed by heavy grazing pressure by livestock the site will convert to one dominated by assorted unpalatable annual and biennial forbs.



## **State 4**

### **Seeded Grassland State**

A seeded grassland state is possible if the site is tilled and re-seeded to increase forage for livestock and to stabilize the streambanks. Species such as meadow foxtail (*Alopecurus pratensis*), tall oatgrass (*Arrhenatherum elatius*), meadow brome (*Bromus biebersteinii*), mountain brome (*Bromus marginatus*), orchardgrass (*Dactylis glomerata*), tufted hairgrass, sheep fescue (*Festuca ovina*), meadow barley (*Hordeum brachyantherum*), and timothy (*Phleum pratense*) may be used. Levels of grazing will have to be controlled (4.2a) or the initially pure grassland (4.1) will quickly be re-invaded by rabbitbrush, sagebrush, willow, or other mesic shrubs (4.2), along with the noxious understory forbs such as burdock, cocklebur, horehound, houndstongue, stickseed, and a variety of thistles. Heavy continuous season long grazing would deplete the seeded grasses, giving an advantage to shrubs and other invasive species (4.1a).

#### **Community 4.1**

##### **Pure grassland**

This plant community is dominated by a suite of seeded montane grass species used to increase forage production for livestock and stabilize streambanks. Species may include meadow foxtail, tall oatgrass, meadow brome, California brome, smooth brome, mountain brome, orchardgrass, tufted hairgrass, sheep fescue, meadow barley, and timothy.

#### **Community 4.2**

##### **Shrub & weed invaded grassland**

This plant community is a product of heavy grazing on seeded grass species. Seeded grasses are diminished and an encroachment of woody species including willow, sagebrush, or rabbitbrush has occurred.

#### **Pathway 4.1a**

##### **Community 4.1 to 4.2**

Heavy continuous season-long grazing will deplete the seeded grasses, allowing shrubs and other invasive species to re-establish.

#### **Pathway 4.2a**

##### **Community 4.2 to 4.1**

Moderation of grazing is required to sustain a purely grassland phase.

#### **Transition T1a**

##### **State 1 to 2**

The simultaneous introduction of exotic species, both plants and animals, and possible extinctions of native flora and fauna, along with climate change, has caused State 1 to transition to State 2. Reversal of such historic changes (i.e. a return pathway) back to State 1 is not practical.

#### **Transition T2a**

##### **State 2 to 3**

Excessive season-long livestock (or trail stock use in the past) involves high intensities of forage utilization, trampling, and bedding. Salting was common on such locations. When ground cover is reduced, accelerated soil erosion is possible. These impacts, along with logging in the watersheds above, results in accelerated channel down-cutting, more extreme flooding, and changes in drainage patterns. The overall result is a xerification of the site and lignification of its vegetation (an increase in woody vegetation). The approach to this transition is indicated by changes in species composition – primarily an increase in woody vegetation. The trigger causing this transition is stream down-cutting due to extreme hydrologic events.

## Restoration pathway R3a State 3 to 2

It may be possible for this site to recover to a willow-dominated system where beaver populations and activity have been restored. The ponding caused by construction of beaver dams helps raise the water table, creating a less favorable environment for the upland species that moved in and allows the original mesic species to re-occupy the site.

## Transition T3a State 3 to 4

If managers are dissatisfied with the levels of productivity and the dominance of undesirable and noxious weeds present in State 3, the location is suitable, and finances are available, they could till and re-seed with a suite of montane grasses that would not only increase forage but may help to stabilize streambanks as well.

## Additional community tables

Table 9. Community 1.1 plant community composition

Group	Common Name	Symbol	Scientific Name	Annual Production (Lb/Acre)	Foliar Cover (%)
<b>Grass/Grasslike</b>					
0	<b>Dominant Grasses</b>			566–1158	
1	<b>Sub-Dominant Grasses</b>			644–1157	
	Grass, annual	2GA	<i>Grass, annual</i>	257–386	–
	Grass, perennial	2GP	<i>Grass, perennial</i>	257–386	–
	slender wheatgrass	ELTR7	<i>Elymus trachycaulus</i>	26–77	–
	western wheatgrass	PASM	<i>Pascopyrum smithii</i>	26–77	–
	alpine timothy	PHAL2	<i>Phleum alpinum</i>	26–77	–
	muttongrass	POFE	<i>Poa fendleriana</i>	26–77	–
<b>Forb</b>					
2	<b>Forbs</b>			904–1927	
	Forb, annual	2FA	<i>Forb, annual</i>	257–386	–
	Forb, perennial	2FP	<i>Forb, perennial</i>	257–386	–
	common yarrow	ACMI2	<i>Achillea millefolium</i>	26–77	–
	nettleleaf giant hyssop	AGUR	<i>Agastache urticifolia</i>	26–77	–
	tall mountain larkspur	DESC	<i>Delphinium scaposum</i>	26–77	–
	field horsetail	EQAR	<i>Equisetum arvense</i>	26–77	–
	northern bedstraw	GABO2	<i>Galium boreale</i>	26–77	–
	common cowparsnip	HEMA80	<i>Heracleum maximum</i>	26–77	–
	Nevada pea	LALA3	<i>Lathyrus lanszwertii</i>	26–77	–
	feathery false lily of the valley	MARAR	<i>Maianthemum racemosum</i> ssp. <i>racemosum</i>	26–77	–
	thickleaf ragwort	SECR	<i>Senecio crassulus</i>	26–77	–
	alpine clover	TRDA2	<i>Trifolium dasyphyllum</i>	26–77	–
	tobacco root	VAED	<i>Valeriana edulis</i>	26–77	–
	hookedspur violet	VIAD	<i>Viola adunca</i>	26–77	–
<b>Shrub/Vine</b>					
3	<b>Shrubs</b>			1413–2061	
	Shrub (>.5m)	2SHRUB	<i>Shrub (&gt;.5m)</i>	643–771	–

	gray alder	ALIN2	<i>Alnus incana</i>	77-129	-
	Saskatoon serviceberry	AMAL2	<i>Amelanchier alnifolia</i>	77-129	-
	water birch	BEOC2	<i>Betula occidentalis</i>	77-129	-
	redosier dogwood	COSES	<i>Cornus sericea ssp. sericea</i>	77-129	-
	mallow ninebark	PHMA5	<i>Physocarpus malvaceus</i>	77-129	-
	Bebb willow	SABE2	<i>Salix bebbiana</i>	77-129	-
	Booth's willow	SABO2	<i>Salix boothii</i>	77-129	-
	Drummond's willow	SADR	<i>Salix drummondiana</i>	77-129	-
	yellow willow	SALU2	<i>Salix lutea</i>	77-129	-
	Pacific willow	SALUL	<i>Salix lucida ssp. lasiandra</i>	77-129	-
<b>Tree</b>					
4	<b>Trees</b>			78-387	
	Engelmann spruce	PIEN	<i>Picea engelmannii</i>	26-129	-
	blue spruce	PIPU	<i>Picea pungens</i>	26-129	-
	narrowleaf cottonwood	POAN3	<i>Populus angustifolia</i>	26-129	-

## Animal community

This site produces a large volume of nutritious forage. To control soil erosion and degradation of the plant community this site may be properly grazed early with the animals being removed early to allow key plants to go ungrazed during the last part of the growing season. A stubble height of 4-6 inches should be adhered to.

The potential is fair to poor for open land, good to fair for woodland, good to fair for wetland and poor to fair for rangeland habitat

It is fair to good all around habitat for chukers, Hungarian partridge, quail, mule deer, moose, pheasants, songbirds, snowshoe rabbits, cottontails, coyotes, cougars, golden eagle, bald eagles and hawks. The diversity and interspersed of grasses, forbs, shrubs, and trees provide good habitat for most wildlife.

## Hydrological functions

Soils in this site are in d hydrologic group due to water table. They have a high runoff potential. When the vegetation is in climax, the hydrologic curves will be 85 and 86. Refer to National Engineering Handbook Section 4 (USDA - NRCS) to determine runoff quantities from these curves. When range condition has declined from the climax, field investigations are needed in order to determine hydrologic curve numbers.

## Recreational uses

This site has good values for aesthetics and natural beauty. It has a large number of forbs and shrubs which have flowers in bloom from early spring throughout the summer and into the fall. It has a combination of grasses, forbs, small shrubs, large shrubs, and trees, which offer some possibilities for screening and value as camping and picnicking areas. Hunting for upland game birds, snowshoe rabbits, elk, and mule deer is good to excellent on this site. Fishing is opportune on streams through and adjacent to this site.

## Wood products

Values exist for saw logs primarily for sheathing, but in most instances it would be more feasible to leave the trees for aesthetic values and recreation. Posts and poles and crating lumber can be harvested from cottonwoods, water birch and thinleaf alder, but they are of much inferior quality to pine or fir. These trees produce suitable wood for fireplaces, campfires, and materials for novelties and ornamental uses.

## Inventory data references

Information presented here has been derived from NRCS clipping data and other inventory data. Field observations

from range trained personnel were also used.

## Type locality

Location 1: AL	
General legal description	Modal Soil: Fluvaquentic Hapoborolls, 1-6% – Fluvaquentic Haploborolls Type Location: Beaver SCD; Bottoms in North Creek Northeast of Beaver, Utah

## Other references

Galatowitsch, S.M. 1990. Using the original land survey notes to reconstruct pre-settlement landscapes in the American West. Great Basin Naturalist: 50(2): 181-191. Keywords: [Western U.S., conservation, history, human impact]

USDA-NRCS. 2003. National Range and Pasture Handbook. in USDA, editor, USDA-Natural Resources Conservation Service-Grazing Lands Technology Institute. Keywords: [Western US, Federal guidelines, Range pasture management]

## Contributors

Darryl L. Trickler  
David J. Somorville  
Dr. R. Douglas Ramsey, USU  
Dr. Neil E. West, USU  
Dr. Leila Shultz, USU  
John Lowry, USU  
Lisa Langs Stoner, USU  
Kate Peterson, USU  
Samuel Rivera, USU

## Approval

Kendra Moseley, 2/05/2025

## Rangeland health reference sheet

Interpreting Indicators of Rangeland Health is a qualitative assessment protocol used to determine ecosystem condition based on benchmark characteristics described in the Reference Sheet. A suite of 17 (or more) indicators are typically considered in an assessment. The ecological site(s) representative of an assessment location must be known prior to applying the protocol and must be verified based on soils and climate. Current plant community cannot be used to identify the ecological site.

Author(s)/participant(s)	
Contact for lead author	
Date	02/26/2025
Approved by	Kendra Moseley
Approval date	
Composition (Indicators 10 and 12) based on	Annual Production

## Indicators

1. **Number and extent of rills:**
-

---

2. **Presence of water flow patterns:**

---

3. **Number and height of erosional pedestals or terracettes:**

---

4. **Bare ground from Ecological Site Description or other studies (rock, litter, lichen, moss, plant canopy are not bare ground):**

---

5. **Number of gullies and erosion associated with gullies:**

---

6. **Extent of wind scoured, blowouts and/or depositional areas:**

---

7. **Amount of litter movement (describe size and distance expected to travel):**

---

8. **Soil surface (top few mm) resistance to erosion (stability values are averages - most sites will show a range of values):**

---

9. **Soil surface structure and SOM content (include type of structure and A-horizon color and thickness):**

---

10. **Effect of community phase composition (relative proportion of different functional groups) and spatial distribution on infiltration and runoff:**

---

11. **Presence and thickness of compaction layer (usually none; describe soil profile features which may be mistaken for compaction on this site):**

---

12. **Functional/Structural Groups (list in order of descending dominance by above-ground annual-production or live foliar cover using symbols: >>, >, = to indicate much greater than, greater than, and equal to):**

Dominant:

Sub-dominant:

Other:

Additional:

---

13. **Amount of plant mortality and decadence (include which functional groups are expected to show mortality or decadence):**

---

14. **Average percent litter cover (%) and depth ( in):**

---

15. **Expected annual annual-production (this is TOTAL above-ground annual-production, not just forage annual-production):**

---

16. **Potential invasive (including noxious) species (native and non-native). List species which BOTH characterize degraded states and have the potential to become a dominant or co-dominant species on the ecological site if their future establishment and growth is not actively controlled by management interventions. Species that become dominant for only one to several years (e.g., short-term response to drought or wildfire) are not invasive plants. Note that unlike other indicators, we are describing what is NOT expected in the reference state for the ecological site:**

---

17. **Perennial plant reproductive capability:**

---