

## Ecological site R047XA410UT Mountain Gravelly Loam (oak)

Last updated: 2/05/2025  
Accessed: 02/20/2025

### General information

**Provisional.** A provisional ecological site description has undergone quality control and quality assurance review. It contains a working state and transition model and enough information to identify the ecological site.

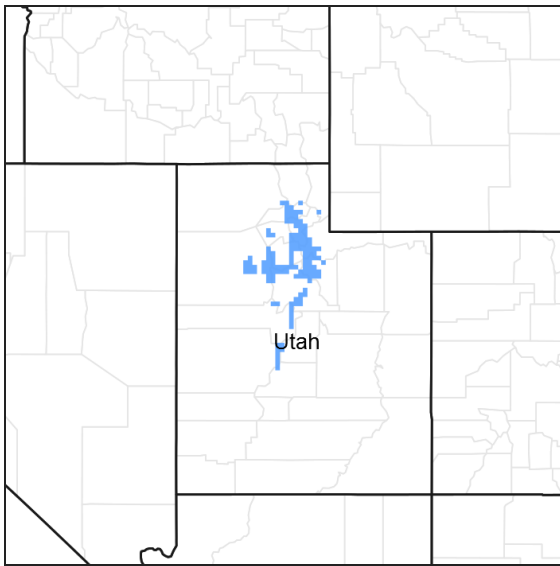

Figure 1. Mapped extent

Areas shown in blue indicate the maximum mapped extent of this ecological site. Other ecological sites likely occur within the highlighted areas. It is also possible for this ecological site to occur outside of highlighted areas if detailed soil survey has not been completed or recently updated.

### MLRA notes

Major Land Resource Area (MLRA): 047X–Wasatch and Uinta Mountains

MLRA 47 occurs in Utah (86 percent), Wyoming (8 percent), Colorado (4 percent), and Idaho (2 percent). It encompasses approximately 23,825 square miles (61,740 square kilometers). The northern half of this area is in the Middle Rocky Mountains Province of the Rocky Mountain System. The southern half is in the High Plateaus of the Utah Section of the Colorado Plateaus Province of the Intermontane Plateaus. Parts of the western edge of this MLRA are in the Great Basin Section of the Basin and Range Province of the Intermontane Plateaus. The MLRA includes the Wasatch Mountains, which trend north and south, and the Uinta Mountains, which trend east and west. The steeply sloping, precipitous Wasatch Mountains have narrow crests and deep valleys. Active faulting and erosion are a dominant force in controlling the geomorphology of the area. The Uinta Mountains have a broad, gently arching, elongated shape. Structurally, they consist of a broadly folded anticline that has an erosion-resistant quartzite core. The Wasatch and Uinta Mountains have an elevation of 4,900 to about 13,500 feet (1,495 to 4,115 meters).

The mountains in this area are primarily fault blocks that have been tilted up. Alluvial fans at the base of the mountains are recharge zones for the basin fill aquifers. An ancient shoreline of historic Bonneville Lake is evident on the footslopes along the western edge of the area. Rocks exposed in the mountains are mostly Mesozoic and Paleozoic sediments, but Precambrian rocks are exposed in the Uinta Mountains. The Uinta Mountains are one of the few ranges in the United States that are oriented west to east. The southern Wasatch Mountains consist of Tertiary volcanic rocks occurring as extrusive lava and intrusive crystalline rocks.

The average precipitation is from 8 to 16 inches (203 to 406 mm) in the valleys and can range up to 73 inches (1854 mm) in the mountains. In the northern and western portions of the MLRA, peak precipitation occurs in the winter months. The southern and eastern portions have a greater incidence of high-intensity summer thunderstorms; hence, a significant amount of precipitation occurs during the summer months. The average annual temperature is 30 to 50 degrees Fahrenheit (-1 to 15 C). The freeze-free period averages 140 days and ranges from 60 to 220 days, generally decreasing in length with elevation.

The dominant soil orders in this MLRA are Aridisols, Entisols, Inceptisols, and Mollisols. The lower elevations are dominated by a frigid temperature regime, while the higher elevations experience cryic temperature regimes. Mesic temperature regimes come in on the lower elevations and south facing slopes in the southern portion of this MLRA. The soil moisture regime is typically xeric in the northern part of the MLRA, but grades to ustic in the extreme eastern and southern parts. The minerology is generally mixed and the soils are very shallow to very deep, generally well drained, and loamy or loamy-skeletal.

## LRU notes

Major Land Resource Unit 47A is located in the northern half of the Middle Rocky Mountains Province of the Rocky Mountain System. This MLRA includes the Wasatch Mountains which tend to run north and south. These steeply sloping, precipitous mountains have narrow crests and deep valleys. They are primarily fault blocks that have been tilted up. The alluvial fans located at the base of these mountains are important recharge zones for valley aquifers.

## Classification relationships

Modal Soil: Ayoub CB-L, Organic Surface 15-40% – fine-loamy, mixed, frigid Typic Argixerolls

## Ecological site concept

Site Concept: The mountain gravelly loam (Gambel oak) site is a patchy gambel oak woodland that occurs on mountain slopes, foothills and ridges of the northern Wasatch mountains. It developed in a continental climate receiving 16 to 22 inches of mostly cool-season precipitation annually. Soils are gravelly or cobbly mollisols (thick, dark surface horizon) at least 20 inches in total depth. The soil moisture regime is xeric and the soil temperature regime is frigid. This site produces 1,450 to 2,250 pounds of vegetation annually. The historic climax plant community is dominated by Gambel oak (*Quercus gambelii*), bluebunch wheatgrass (*Pseudoroegneria spicata*), slender wheatgrass (*Elymus trachycaulis*), and mountain snowberry (*Symphoricarpos oreophilus*).

## Associated sites

R047XA406UT	<b>Mountain Gravelly Loam (mountain big sagebrush)</b> These two sites occur together in distinct patches. Gambel oak rarely propagates from seed in its northern ranges, and mountain big sagebrush cannot invade an oak stand due to resource limitations. The result is a sharp mosaic of oak and sagebrush sites that changes very slowly if at all.
R047XA430UT	<b>Mountain Loam (mountain big sagebrush)</b> This site is often found near the mountain gravelly loam (Gambel oak) site in areas where the soil is deeper and less rocky. Gambel oak rarely propagates from seed in its northern ranges, and mountain big sagebrush cannot invade an oak stand. The result is a sharp mosaic of oak and sagebrush sites that changes very slowly if at all.

## Similar sites

R047XA432UT	<b>Mountain Loam (oak)</b> This site produces taller, more robust oak trees than the mountain gravelly loam (Gambel oak) site and produces less grass. It is found in deeper, less gravelly soils that retain more water. The two are often seen together where a gravelly slope meets a loamy bottom.
R047XA448UT	<b>Mountain Shallow Loam (oak)</b> This site has soils that are less than 20 inches deep, resulting in lower-statured oak and reduced annual production compared to the mountain gravelly loam (oak) site.

R047XA463UT	<b>Mountain Stony Loam (Gambel oak)</b> This site has larger rock fragments in the soil and produces less forb, grass, and shrub biomass than the mountain gravelly loam (oak) site.
R047XA473UT	<b>Mountain Very Steep Stony Loam (browse)</b>

**Table 1. Dominant plant species**

Tree	Not specified
Shrub	(1) <i>Quercus gambelii</i>
Herbaceous	(1) <i>Elymus trachycaulus</i>

## Physiographic features

This site occurs primarily on mountain slopes, foothills, swales and occasionally on alluvial fans and terminal moraines. It is found on all aspects at elevations ranging between 5,200 and 10,000 feet. Runoff varies from medium to very high depending on slope and ground cover. This site is considered a reliable watershed for lower lying areas.

**Table 2. Representative physiographic features**

Landforms	(1) Mountain slope (2) Hill (3) Swale
Flooding frequency	None
Ponding frequency	None
Elevation	5,200–10,000 ft
Slope	15–65%
Aspect	Aspect is not a significant factor

## Climatic features

The climate of this site is characterized by cold snowy winters and cool dry summers. The average precipitation ranges from 16 to 22 inches annually with 55 percent to 60 percent coming during the plant dormant period (October to March). Much of this precipitation comes as snow that acts as a reservoir for water until the growing season begins. This winter moisture is the most dependable supply of water for plant growth. Lower precipitation and higher evapo-transpiration rates during July, August, and September cause a reduction in plant growth for all species and dormancy in many of the grasses and forbs.

**Table 3. Representative climatic features**

Frost-free period (average)	137 days
Freeze-free period (average)	169 days
Precipitation total (average)	22 in

## Influencing water features

Due to its landscape position, this ecological site is not typically influenced by streams or wetlands.

## Wetland description

N/A

## Soil features

The soils on this site were formed in alluvium, colluvium, and residuum derived from various parent materials including sandstone, shale, quartzite and andesite. A thin organic layer of oak leaves and twigs is common on the soil surface and upper soil layers are dark brown in color. These soils formed on mountain slopes, are well-drained, and usually have gravel or cobble on the soil surface. The subsoils are gravelly or cobbly loams with coarse fragments in the root zone averaging 30 percent to 60 percent by volume. They can be moderately deep or deep with bedrock at least 20 inches beneath the soil surface. Available water holding capacity ranges from 1.8 to 4.7 inches if water in the upper 40 inches of soil. The soil moisture regime is xeric and the soil temperature regime is frigid.

Soils Associated With This Site:

Soil Survey Area: Soil Components (Map Units in parentheses)

Fairfield-Nephi Area (UT608): Lizzant (LbE, LbF)

Morgan Area (UT609): Burgi (BuG); Heinholt (EVG, HpG); Horrocks (HvG); Lamondi (LaD, LaE)

Tooele Area (UT611): Smarts (SgG); Toncana (TaG)

Salt Lake Area (UT612): Gappmayer (GEG, GGG)

Summit Area (UT613): Dunford (107, 108, 124, 125)

Millard County (UT618): Lizzant (84); Searla (107)

Utah County (UT621): Dry Creek (DRG2); Gappmayer (GAG); McPhie (HFF, HFG2)

Heber Valley Area (UT622): Burgi (BWE, BWF, BXF, BYF); Gappmayer (GAD, GAF, GMF, GPF, GWF, HGF);

McPhie (MCF, MHF, VMF)

Sevier County (UT628): Lizzant (LMG)

**Table 4. Representative soil features**

Surface texture	(1) Very cobbly loam (2) Gravelly loam (3) Gravelly fine sandy loam
Family particle size	(1) Loamy
Drainage class	Well drained
Permeability class	Moderately slow to moderate
Soil depth	20–60 in
Surface fragment cover <=3"	11–24%
Surface fragment cover >3"	3–30%
Available water capacity (0-40in)	1.8–4.7 in
Calcium carbonate equivalent (0-40in)	0%
Electrical conductivity (0-40in)	0–2 mmhos/cm
Sodium adsorption ratio (0-40in)	0
Soil reaction (1:1 water) (0-40in)	5.6–7.8
Subsurface fragment volume <=3" (Depth not specified)	16–30%
Subsurface fragment volume >3" (Depth not specified)	3–30%

## Ecological dynamics

This site is characterized by Gambel oak dominance with perennial bunchgrasses and forbs in the interspaces. Historically, wildfires rejuvenated aging oak stands every 40-80 years on this site. Gambel oak resprouts vigorously after fire and oak stem density decreases steadily as time without wildfire increases. On higher elevation sites,

mature oak can be invaded by juniper or Douglas fir. These resinous conifers increase the likelihood of wildfire which removes the invaders and resets the Oak to vigorous resprouting and site dominance.

Species that are most likely to invade this site when ecological processes deteriorate are cheatgrass, annual forbs, dalmation toadflax, houndstongue, flannel mullein, salsify and snakeweed. Gambel oak is presumed to increase under excessive grazing or repeated wildfires.

#### Reference State (State 1)

The reference state for the mountain loam (oak) site was determined by study of relic areas that have been protected from altered disturbance regimes and are considered to be representative of the historic climax plant community. Literature reviews, trends in plant community dynamics, and historical accounts are also considered.

State 1, the reference state, represents the historic plant communities of the mountain loam (oak) site and the naturally occurring dynamics associated with those communities. This state includes all known biotic communities that would exist under natural disturbance regimes and current climatic conditions. The dominant overstory species is Gambel oak (*Quercus gambelii*) with the understory dominated by the perennial bunchgrasses slender wheatgrass (*Elymus trachycaulus*) and/or bluebunch wheatgrass (*Elymus spicata*). The plant communities in state 1 are naturally resistant to disturbance and resilient following disturbance due to favorable amounts of precipitation and the ability of Gambel oak to resprout following disturbance. Wildfire is the predominant disturbance affecting ecological processes and is the primary factor driving plant community change in this state. The common fire return interval is 35-100 years and plant recovery following a wildfire is rapid, often with Gambel oak resprouting within the same growing season.

#### Community Phase 1.1 Gambel oak / Perennial Bunchgrasses

This plant community consists of mature Gambel oak trees that dominate the overstory and slender wheatgrass and/or bluebunch wheatgrass that dominate the understory. Mountain brome, Geyer sedge, as well as other cool season grasses may be present. Common shrubs and forbs are mountain snowberry, Saskatoon serviceberry, thickleaf peavine, and a suite of other species adapted to grow either in the interspaces or under the canopy of Gambel oak stands. Bare ground is not common and no non-native plants are present.

#### Community Pathways

1.1a Wildfire --This pathway often occurs late in the growing season when precipitation is low and fuel load is at its peak. Gambel oak is at peak underground carbohydrate storage around this time of year, which provides the energy needed for resprouting.

1.1b No Fire --This pathway is a subsequent step in natural succession that occurs when fire free periods approach their upper limits and allow fire sensitive species to encroach into Gambel oak sites.

#### Community Phase 1.2 Post-fire Community / Resprouting Gambel oak Thicket

This plant community consists of young Gambel oak shoots that are beginning to reestablish following a wildfire. Burned trunks will usually be visible above the new growth. The Gambel oak suckers often form dense thickets of foliage up to several feet in height which effectively intercept sunlight and crowd out potential invaders. Given adequate recovery time of a few months to a year, the interspaces will exhibit native bunchgrasses and forbs, but few shrubs.

#### Community Pathways

1.2a Natural Succession—As the post-fire community ages, Gambel oak becomes less dominant near the soil surface, but maintains its dominance in the canopy. Perennial grasses become more robust and the plant community becomes more diverse with the establishment of shrubs and shade sensitive species.

#### Community Phase 1.3 Encroachment by Other Tree Species

This plant community is comparable in composition to community 1.1 with the addition of fire sensitive tree species such as Rocky mountain Douglas fir, canyon maple, and/or white fir. The percent composition of these tree species is relatively low (3-5%).

#### Community Pathways

1.3a Wildfire-- This pathway often occurs late in the growing season when precipitation is low and fuel load is at its peak. Gambel oak also is at peak carbohydrate storage around this time of year, an adaptation which provides the energy needed to resprout and maintain its niche.

#### Transition 1-- Invasive Plants

Transition from Reference State (State 1) to current Potential State (State 2)

This transition occurs when non-native or invasive species become established in the plant community. Common invasive species include Dalmation toadflax, annual forbs, dandelion, houndstongue, rubber rabbitbrush, broom snakeweed, and cheatgrass. Intermediate wheatgrass, smooth brome, and Kentucky bluegrass may also spread into the site. Events that may facilitate the establishment of non-native plants are wildfire, introduction of livestock, seeding, and recreation.

#### Current Potential State (State 2)

State 2 is very similar to State 1 in form and function, with the exception of the presence of non-native plants and animals, possible extinctions of native species, and a different climate. State 2 is a description of the ecological site shortly following Euro-American settlement.

#### Community Phase 2.1 Gambel oak / Slender wheatgrass

Phase 2.1 is 10-20% grasses, 0-15% forbs and 80-90% shrubs by air-dry weight. After a fire, Gambel oak sprouts vigorously and suppresses perennial grass and forb production. Non-native species are present, but not dominant.

#### Community Pathways

2.1a Wildfire -- This pathway often occurs late in the growing season when precipitation is low and fuel load is at its peak. Gambel oak is at peak underground carbohydrate storage around this time of year, which provides the energy needed for resprouting.

2.1b No Fire -- This pathway is a subsequent step in natural succession that occurs when fire free periods approach their upper limits and allow fire sensitive species to encroach into Gambel oak sites.

2.1c Prescribed Fire and Re-seed – This pathway occurs when land owners and/or land managers are attempting to improve the vigor of the native plant community.

2.1d Continuous Heavy Grazing – This pathway occurs when improper grazing continues for extended periods of time not allowing for native plants to recover, ultimately lowering the health and vigor of these plants to compete with available resources.

#### Community Phase 2.2 Resprouting Gambel oak thicket

Phase 2.2 is 20-40% grasses, 10-25% forbs, and 50-70% shrubs. Gambel oak stem density is less than phase 1.1, though oak production may be higher. Non-native species are present, but not dominant.

#### Community Pathways

2.2a Natural Succession on the site

#### Community Phase 2.3 Encroachment by other tree species

Phase 2.3 is characterized by encroachment of conifer species including Douglas fir, juniper and pinyon. Higher elevations of this ecological site are more susceptible to conifer encroachment. At lower elevations, this phase is characterized by decadent Gambel oak with patches of young sprouts. Gambel oak dies naturally around 80 years of age and promptly responds with vigorous young sprouts to replace the oak foliage. Native species are present, but not dominant

#### Community Pathways

2.3a Wildfire -- This pathway often occurs late in the growing season when precipitation is low and fuel load is at its peak. Gambel oak is at peak underground carbohydrate storage around this time of year, which provides the energy needed for resprouting.

2.3b Brush Management (Fire) and re-seeding – Utilization of techniques such as prescribed fire and range seeding can reduce composition of invading conifers as well as temporarily reduce competition from oak to allow for the herbaceous component to become established.

2.3c Continuous Heavy Grazing -- This pathway occurs when improper grazing continues for extended periods of time not allowing for native herbaceous plants and shrubs to recover, ultimately lowering the health and vigor of these plants to compete with available resources.

### Community Phase 2.4 Seeded Gambel oak Woodland

Phase 2.4 is an aerial seeding following fire. Both native and non-native perennial grasses and forbs are included in most seed mixes. Under proper grazing, native grass and forb species can out-compete introduced species and dominate the understory within 5-10 years.

#### Community Pathways

2.4a Wildfire -- This pathway often occurs late in the growing season when precipitation is low and fuel load is at its peak. Gambel oak is at peak underground carbohydrate storage around this time of year, which provides the energy needed for resprouting.

2.4b Natural Succession/prescribed grazing – This pathway can occur through natural succession and prescribed grazing. Over time the oak will begin to be the dominant aspect on the site, and with proper grazing management the herbaceous understory and shrubs will maintain health and vigor on the site.

2.4c Continuous Heavy Grazing -- This pathway occurs when improper grazing continues for extended periods of time not allowing for native herbaceous plants and shrubs to recover, ultimately lowering the health and vigor of these plants to compete with available resources.

### Community Phase 2.5 Overgrazed Gambel oak

Phase 2.5 displays a reduction in the herbaceous understory and/or shrub component due to improper grazing/browsing from livestock and/or wildlife.

#### Community Pathways

2.5a No Fire – lack of fire over time will allow other tree species to naturally encroach into the site.

2.5b Brush Management (Mechanical) and re-seeding -- utilization of techniques such as mechanical brush management and range seeding can reduce composition of oak to allow for the herbaceous component to become established.

2.5c Natural succession and prescribed grazing – practicing prescribed grazing over time will allow the herbaceous and shrub components to become established on this site.

### Transition 2 Noxious Weed Invasion / Repeated Wildfires

Transition from State 2 to State 3

### Transition 3 Prescribed Grazing (Goats)

Transition from State 2 to State 4

### State 3 Noxious Weed State

State 3 is characterized by a dominance of non-native noxious weeds. The threshold has been crossed into State 3 and the dynamics of this site will likely prohibit the return back into State 2 without an extraordinary amount of external inputs.

### Community Phase 3.1 Broadleaf weed dominates interspaces

Native herbaceous and/or shrubs have largely been replaced by prolific noxious weeds establishment which generally flourish in sites where there is a short fire return interval. This process makes it incredibly hard for native herbaceous species to become reestablished on the site. Gambel oak is able to remain on this site by utilizing available resources due to its extensive root system and its sprouting abilities following wildfire.

#### Community Pathway

3.1a Wildfire – The nature of this site with the abundance of noxious weeds/fine fuels shortens the fire return interval compared to the historic fire regime.

### Community Phase 3.2 Weed co-dominant with resprouting Gambel oak

Following a wildfire, the herbaceous weed component and sprouting Gambel oak will dominate this site.

#### Community Pathway

3.2a Natural Succession – Due to the nature of this site, there is often a frequent fire return interval which will return this site back to Community Phase 3.1.

State 4: Herbaceous State:

Utilizing browsing animals such as goats, the threshold from State 2 is crossed in to this State. Browsing animals will shift the competitive advantage to the herbaceous component leaving the site devoid of Gambel oak and dominated by the herbaceous understory.

Community Phase 4.1 Devoid of Gambel oak

## **State and transition model**



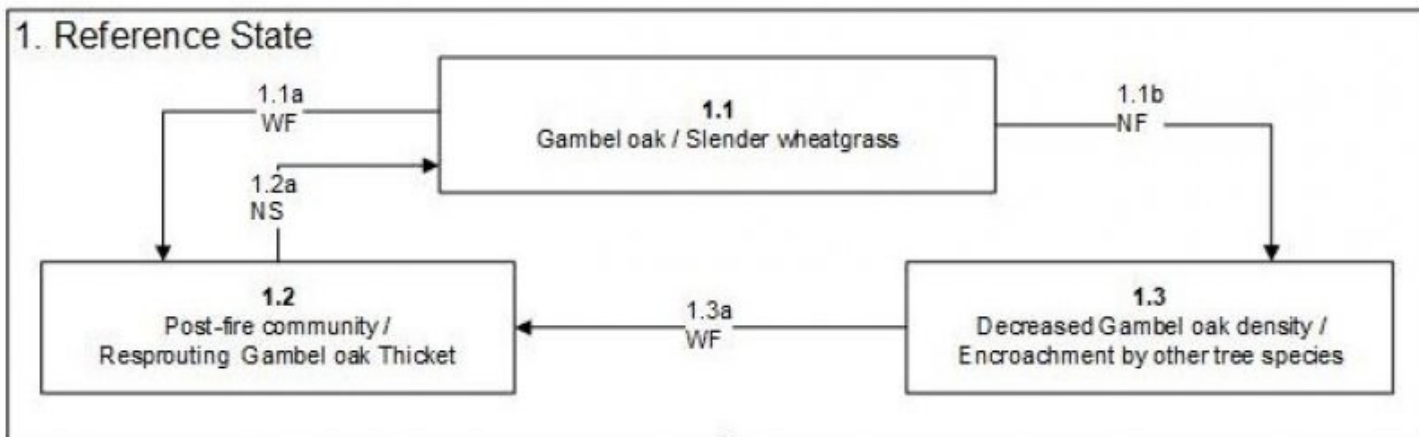

T1  
IP

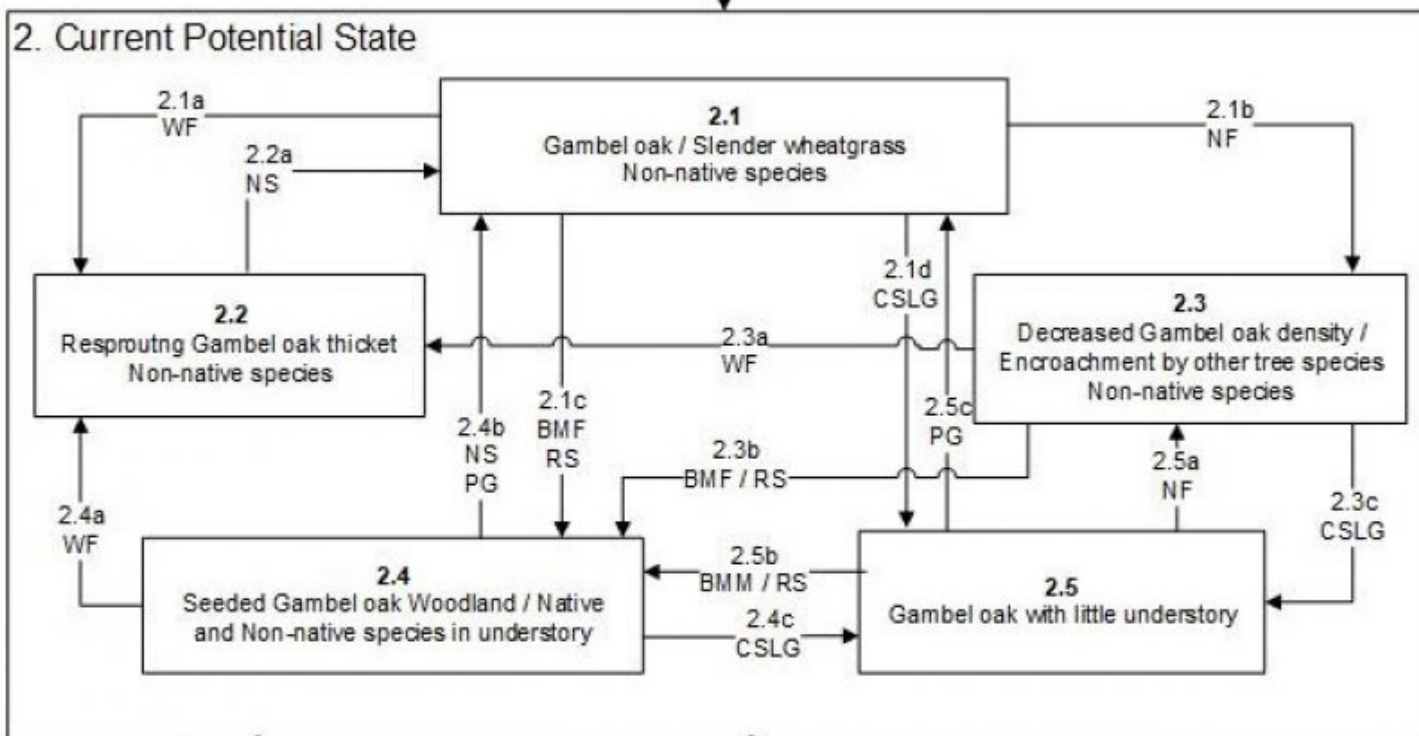

T2  
NWI / RWF

T3  
PG (Goats)

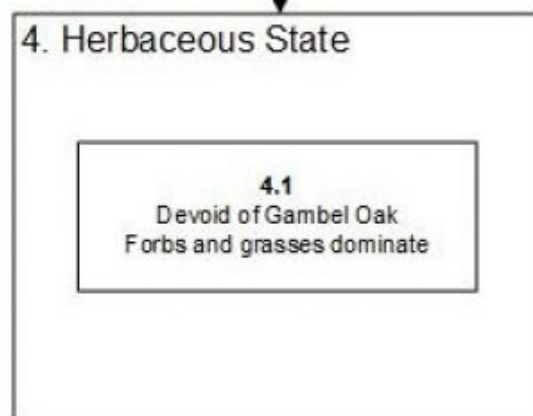
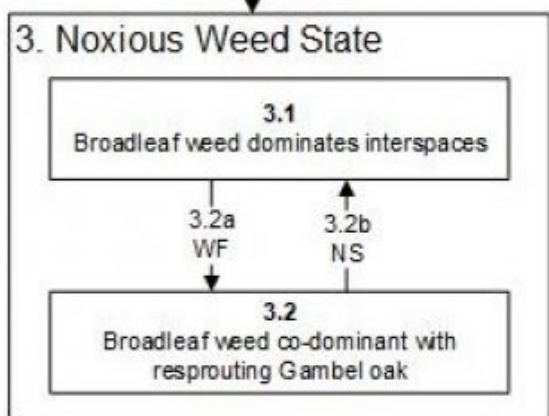

**Legend:** WF = Wildfire      NF = No Fire      BMM = Brush Management (Mechanical)  
 RS = Re-seeding      NS = Natural Succession      BMF = Brush Management (Fire)  
 PG = Prescribed Grazing      RWF = Recurring Wildfire      CSLG = Continuous Season-long Grazing  
 RPT = Replant Trees      IP = Introduced Species      NWI = Noxious Weed Invasion

## **Animal community**

### **Livestock:**

This site provides a good balance of nutritious forage when oak, perennial grasses, and forbs are all present. Sheep, cattle, and horses do well grazing during the spring, summer, and fall. Goats often prefer Gambel oak and are capable of consuming over 50% oak in their diet. Tannic acid is present in all parts of oak plants and may become fatal to livestock when oak is the only source of available forage.

### **Wildlife:**

Gambel oak is a primary food and nesting resource for porcupines in the winter. Squirrels, deer, and upland birds consume acorns during the fall and winter. This site is good habitat for chukars, quail, turkeys, songbirds, squirrels, snowshoe hares, cottontails, bobcat, coyotes, mule deer, and elk. It is fair habitat for golden eagle, hawks, cougars, bear, and small mammals.

## **Recreational uses**

This site has aesthetic value and is excellent for hunting big game. A large number of forbs and shrubs are in bloom from early spring and throughout the summer and fall. Wildlife can often be viewed throughout the year. Shrubs offer screening for camping areas and picnicking.

This site is often used for hunting upland game birds, coyotes, snowshoe hares, elk and mule deer. Motorized recreation is dependent on road access.

## **Wood products**

Not all gambel oak stands will grow large enough to be harvested for firewood, especially if the growing season is too short or the soil too shallow. Mature gambel oak stands can be harvested for fence posts, stays and firewood. It is moderately weather-resistant and extremely hard. However, when moist it tends to rot more quickly than other post materials. As a fuelwood, gambel oak is desirable because it gives off high amounts of heat and little smoke or soot. Though not used for lumber, gambel oak has some value for small wooden crafts. A harvested stand resprouts immediately afterward and usually takes about 60 years to regenerate fully.

## **Inventory data references**

Information presented here has been derived from NRCS clipping data and other inventory data. Field observations from range trained personnel were also used.

## **Other references**

UDWR, Utah Big Game Range Trend Studies. 2007. Available at:  
<http://wildlife.utah.gov/range/statewide%20management%20units.htm>. Accessed 5 February 2009.

Western Regional Climate Center, Western U.S. Climate Historical Summaries. Available at:  
<http://www.wrcc.dri.edu/summary/Climsmut.html>. Accessed 5 February 2009.

Web Soil Survey, Official Soil Series Descriptions. Available at:  
<http://soils.usda.gov/technical/classification/osd/index.html>. Accessed 20 February 2009.

## **Contributors**

Darryl L. Trickler, Tim Watson  
Jamin Johanson

## **Approval**

Kendra Moseley, 2/05/2025

## **Rangeland health reference sheet**

Interpreting Indicators of Rangeland Health is a qualitative assessment protocol used to determine ecosystem condition based on benchmark characteristics described in the Reference Sheet. A suite of 17 (or more) indicators are typically considered in an assessment. The ecological site(s) representative of an assessment location must be known prior to applying the protocol and must be verified based on soils and climate. Current plant community cannot be used to identify the ecological site.

Author(s)/participant(s)	V. Keith Wadman (NRCS Retired), Shane A. Green
Contact for lead author	shane.green@ut.usda.gov
Date	11/09/2012
Approved by	Kendra Moseley
Approval date	
Composition (Indicators 10 and 12) based on	Annual Production

## Indicators

1. **Number and extent of rills:** None to very rare. Some very minor rill development may occur on steeper slopes (> 20%) or on areas located below exposed bedrock or other water shedding areas where increased runoff may occur. Where these rills are present, they should be fairly short (4-8 feet), < 1 inch deep and somewhat widely spaced (5-10 feet). Minor rill development may be observed on all slopes following major thunderstorm or spring runoff events but should heal during the next growing season.

---

2. **Presence of water flow patterns:** Slight. Some minor evidence of water flow patterns may be found winding around perennial plant bases. They show little evidence of current erosion. They are expected to be short (3-6 feet), stable, sinuous and normally not connected. There may be very minor evidence of deposition. Evidence of water flow may increase somewhat in slopes > 20%.

---

3. **Number and height of erosional pedestals or terracettes:** Perennial vegetation shows none to very little evidence of erosional pedestalling (1 to 2% of individual plants). Plant roots are covered and most litter remains in place around plant crowns. Terracettes should be absent or, if present, stable. A slight increase in both pedestal and terracette development may occur with increasing slope.

---

4. **Bare ground from Ecological Site Description or other studies (rock, litter, lichen, moss, plant canopy are not bare ground):** Bare ground ranges from 15% - 20%. Soil surface may be covered by 20 to 45% coarse fragments. Bare ground openings should not be greater than 1 foot in diameter and should normally not be connected.

---

5. **Number of gullies and erosion associated with gullies:** None to Rare at site level. Scattered landscape level gully channels, however, are a normal component of basin/range environments. Where landscape gullies are present, they should be stable, partially vegetated on their sides and bottoms, with no evidence of head-cutting. Some slight increase in disturbance may be evident following significant weather events or when gullies convey considerable runoff from higher elevation rocky or naturally eroding areas.

---

6. **Extent of wind scoured, blowouts and/or depositional areas:** None. No evidence of wind generated soil movement is present. Wind caused blowouts and deposition are not present.

- 
7. **Amount of litter movement (describe size and distance expected to travel):** Most litter resides in place with some redistribution caused by water movement. Minor litter removal may occur in flow channels with deposition occurring within 1 to 2 feet at points of obstruction. The majority of litter accumulates at the base of plants. Some grass leaves and small twigs (grass stems) may accumulate in soil depressions adjacent to plants. Woody stems are not likely to move. However, some litter movement is expected (up to 6 feet) with increases in slopes >20% and/or increased runoff resulting from heavy thunderstorms.
- 
8. **Soil surface (top few mm) resistance to erosion (stability values are averages - most sites will show a range of values):** This site should have a soil stability rating of 5 or 6 under the plant canopies, and a rating of 4 to 5 in the interspaces. The average rating should be a 5. Soil surface textures are typically loams, very fine sandy loams and silt loams.
- 
9. **Soil surface structure and SOM content (include type of structure and A-horizon color and thickness):** (Henhoit) Soil surface 0-2 inches. Surface texture is a gravelly loam which may have an organic mat of partially decomposed leaves and twigs 1 to 3 inches deep on the surface; color is dark reddish brown (5YR 3/2); and structure is moderate fine granular. Mollic epipedon ranges to 19 inches. Use the specific information for the soil you are assessing found in the published soil survey to supplement this description.
- 
10. **Effect of community phase composition (relative proportion of different functional groups) and spatial distribution on infiltration and runoff:** Perennial vegetation produces sufficient cover and spatial arrangement to intercept most raindrops and reduce raindrop splash erosion. Litter on soil surface and cryptogamic crusting, where present, also protects soil from splash erosion and encourages a higher rate of infiltration. Plant spatial distribution should slow runoff, allowing additional time for infiltration. Bare spaces are expected to be small and irregular in shape and are usually not connected. Vegetative structure is usually adequate to capture snow and ensure that snowmelt occurs in a controlled manner, allowing maximum time for infiltration, and reducing runoff and erosion in all but the most extreme storm events. When perennial grasses and shrubs decrease due to natural events including drought, insect damage, etc., which reduce ground cover and increase bare ground, runoff is expected to increase and associated infiltration reduced.
- 
11. **Presence and thickness of compaction layer (usually none; describe soil profile features which may be mistaken for compaction on this site):** None. Some soils have natural textural variability within their profiles including changes in clay content, these should not be mistaken for a compaction pan.
- 
12. **Functional/Structural Groups (list in order of descending dominance by above-ground annual-production or live foliar cover using symbols: >>, >, = to indicate much greater than, greater than, and equal to):**
- Dominant: Trees (Gamble Oak) >> Sprouting Shrubs (Mountain snowberry) > Rhizomatous grasses (slender wheatgrass) > Perennial bunchgrasses and grasslikes (bluebunch wheatgrass, Geyer sedge) = > Non-sprouting shrub (mountain big sagebrush).
- Sub-dominant: Perennial forbs (thickleaf peavine).
- Other: A wide variety of other perennial grasses and both perennial and annual forbs can be expected to occur in the plant community.

Additional: Natural disturbance regimes include fire, drought, and insects. Assumed fire cycle of 40 to 60+ years. Functional/structural groups may appropriately contain non-native species if their ecological function is the same as the native species in the reference. Following a disturbance such as fire, drought, rodents or insects that remove woody vegetation, forbs and perennial grasses (herbaceous species) may dominate the community for a period of time. If a disturbance has not occurred for an extended period of time, woody species may continue to increase. These conditions would reflect different functional community phases within the reference state.

---

13. **Amount of plant mortality and decadence (include which functional groups are expected to show mortality or decadence):** All age classes of perennial grasses should be present under average to above average growing conditions with age class expression likely subdued during periods of extended drought. Slight decadence in the principle shrubs could occur near the end of the fire cycle or during periods of extended drought, or insect infestations. In general, a mix of age classes should be expected with some dead and decadent plants present.

---

14. **Average percent litter cover (%) and depth ( in):** Litter cover will be heavier under plants. Most litter will be herbaceous and depths of 1 to 3 inches would be considered normal. Perennial vegetation should be well distributed on the site.

---

15. **Expected annual annual-production (this is TOTAL above-ground annual-production, not just forage annual-production):** Annual production in air-dry herbage should be approximately 1900 - 2000 #/acre on an average year but could range from 1400 - 2300 #/acre during periods of prolonged drought or above average precipitation.

---

16. **Potential invasive (including noxious) species (native and non-native). List species which BOTH characterize degraded states and have the potential to become a dominant or co-dominant species on the ecological site if their future establishment and growth is not actively controlled by management interventions. Species that become dominant for only one to several years (e.g., short-term response to drought or wildfire) are not invasive plants. Note that unlike other indicators, we are describing what is NOT expected in the reference state for the ecological site:** Cheatgrass, alyssum, mustard species, Canada thistle, black medic, Utah juniper.

---

17. **Perennial plant reproductive capability:** All perennial plants should have the ability to reproduce in all years, except in extreme drought years. Green rabbitbrush sprouts vigorously following fire. There are no restrictions on either seed or vegetative reproduction. Some seedling recruitment of major species is expected to be present during average and above average growing years.

---