

## Ecological site R047XB463UT Mountain Stony Loam (oak)

Last updated: 2/11/2025  
Accessed: 02/26/2025

---

### General information

**Provisional.** A provisional ecological site description has undergone quality control and quality assurance review. It contains a working state and transition model and enough information to identify the ecological site.

### MLRA notes

Major Land Resource Area (MLRA): 047X–Wasatch and Uinta Mountains

MLRA 47 occurs in Utah (86 percent), Wyoming (8 percent), Colorado (4 percent), and Idaho (2 percent). It encompasses approximately 23,825 square miles (61,740 square kilometers). The northern half of this area is in the Middle Rocky Mountains Province of the Rocky Mountain System. The southern half is in the High Plateaus of the Utah Section of the Colorado Plateaus Province of the Intermontane Plateaus. Parts of the western edge of this MLRA are in the Great Basin Section of the Basin and Range Province of the Intermontane Plateaus. The MLRA includes the Wasatch Mountains, which trend north and south, and the Uinta Mountains, which trend east and west. The steeply sloping, precipitous Wasatch Mountains have narrow crests and deep valleys. Active faulting and erosion are a dominant force in controlling the geomorphology of the area. The Uinta Mountains have a broad, gently arching, elongated shape. Structurally, they consist of a broadly folded anticline that has an erosion-resistant quartzite core. The Wasatch and Uinta Mountains have an elevation of 4,900 to about 13,500 feet (1,495 to 4,115 meters).

The mountains in this area are primarily fault blocks that have been tilted up. Alluvial fans at the base of the mountains are recharge zones for the basin fill aquifers. An ancient shoreline of historic Bonneville Lake is evident on the footslopes along the western edge of the area. Rocks exposed in the mountains are mostly Mesozoic and Paleozoic sediments, but Precambrian rocks are exposed in the Uinta Mountains. The Uinta Mountains are one of the few ranges in the United States that are oriented west to east. The southern Wasatch Mountains consist of Tertiary volcanic rocks occurring as extrusive lava and intrusive crystalline rocks.

The average precipitation is from 8 to 16 inches (203 to 406 mm) in the valleys and can range up to 73 inches (1854 mm) in the mountains. In the northern and western portions of the MLRA, peak precipitation occurs in the winter months. The southern and eastern portions have a greater incidence of high-intensity summer thunderstorms; hence, a significant amount of precipitation occurs during the summer months. The average annual temperature is 30 to 50 degrees Fahrenheit (-1 to 15 C). The freeze-free period averages 140 days and ranges from 60 to 220 days, generally decreasing in length with elevation.

The dominant soil orders in this MLRA are Aridisols, Entisols, Inceptisols, and Mollisols. The lower elevations are dominated by a frigid temperature regime, while the higher elevations experience cryic temperature regimes. Mesic temperature regimes come in on the lower elevations and south facing slopes in the southern portion of this MLRA. The soil moisture regime is typically xeric in the northern part of the MLRA, but grades to ustic in the extreme eastern and southern parts. The mineralogy is generally mixed and the soils are very shallow to very deep, generally well drained, and loamy or loamy-skeletal.

### LRU notes

E47B is the Wasatch Mountains South MLRA. It occurs in the Loa, Panguitch, New Harmony area. Most of Zion, Bryce Canyon National Parks and Cedar Breaks National Monument are in this area. This area is composed of mountain ranges that run north and south.

## Ecological site concept

The soils of this site formed mostly in colluvium and/or residuum from mixed sources. Surface soils are loamy sand, extremely cobbly loam to gravelly loam in texture. Rock fragments may be present on the soil surface and throughout the profile and can make up more than 35 percent of the soil volume. These soils are generally moderately deep but can be shallow, well-drained, and have moderately slow to moderately rapid permeability. pH is slightly acidic to moderately alkaline. Available water-holding capacity ranges from 3.0 to 4.5 inches of water in the upper 40 inches of soil. The soil moisture regime is mostly ustic and the soil temperature regime is frigid. Precipitation ranges from 16 to 22 inches annually.

## Associated sites

R047XB462UT	<b>Mountain Stony Loam (mountain big sagebrush)</b> These sites can occur adjacent to each other.
-------------	--

## Similar sites

R047XB432UT	<b>Mountain Loam (oak)</b> These sites have similar flora characteristics, however this site has less rock fragment in the soil profile.
-------------	---

Table 1. Dominant plant species

Tree	Not specified
Shrub	(1) <i>Quercus gambelii</i>
Herbaceous	Not specified

## Physiographic features

This ecological site typically occurs on mountain slopes and hillslopes. Slopes normally range from 15 to 60 percent but may occasionally be steeper. Slope steepness, aspect and elevation will influence the vegetative floristics of this site. Sites are typically located between 6,000 to 9,400 feet in elevation. Runoff is medium to very high.

Table 2. Representative physiographic features

Landforms	(1) Mountain slope (2) Hillslope
Runoff class	Medium to very high
Flooding frequency	None
Ponding frequency	None
Elevation	6,000–9,400 ft
Slope	15–60%
Aspect	Aspect is not a significant factor

## Climatic features

Climate is characterized by cool summers and cold winters. The annual precipitation on this site occurs with about 50 percent arriving during the growing season. The wettest months are August through March. The driest are May and June. The average snow depth in the winter is between 12 and 24 inches. Summer thunderstorms are typical in July and August. Mean annual temperature is 45 degrees.

Table 3. Representative climatic features

Frost-free period (characteristic range)	
Freeze-free period (characteristic range)	80-110 days

Precipitation total (characteristic range)	16-22 in
--	----------

## Influencing water features

Due to its landscape position, this site is not influenced by streams or wetlands.

## Wetland description

N/A

## Soil features

The soils of this site formed mostly in colluvium and residuum from mixed sources. Surface soils are loamy sand, extremely cobbly loam to gravelly loam in texture. Rock fragments may be present on the soil surface and throughout the profile and can make up more than 35 percent of the soil volume. These soils are generally moderately deep but can be shallow, well-drained, and have moderately slow to moderately rapid permeability. pH is slightly acidic to moderately alkaline. Available water-holding capacity ranges from 3.0 to 4.5 inches of water in the upper 40 inches of soil. The soil moisture regime is mostly ustic and the soil temperature regime is frigid. Precipitation ranges from 16 to 22 inches annually.

**Table 4. Representative soil features**

Parent material	(1) Colluvium—igneous, metamorphic and sedimentary rock (2) Residuum—igneous, metamorphic and sedimentary rock
Surface texture	(1) Gravelly, extremely cobbly loam (2) Loamy sand
Family particle size	(1) Clayey-skeletal (2) Loamy-skeletal
Drainage class	Well drained
Permeability class	Slow to moderate
Depth to restrictive layer	20–40 in
Soil depth	20–40 in
Surface fragment cover <=3"	5–20%
Surface fragment cover >3"	0–25%
Available water capacity (20-40in)	3–4.5 in
Calcium carbonate equivalent (20-40in)	0–5%
Electrical conductivity (20-40in)	0–2 mmhos/cm
Sodium adsorption ratio (20-40in)	0
Soil reaction (1:1 water) (20-40in)	6.1–8.4
Subsurface fragment volume <=3" (20-40in)	10–35%
Subsurface fragment volume >3" (20-40in)	0–30%

## Ecological dynamics

Reference State (State 1)

The Reference State for the Mountain Stony Loam (oak) site was determined by study of relic areas that have been protected from altered disturbance regimes and are considered to be representative of the historic climax plant community. Literature reviews, trends in plant community dynamics, and historical accounts are also considered.

State 1, the reference state, represents the Historic Climax Plant Communities of the Mountain Gravelly Loam (oak) site and the naturally occurring dynamics associated with those communities. This state includes all known biotic communities that would exist under natural disturbance regimes and current climatic conditions. The dominant overstory species is gambel oak (*Quercus gambelii*) with the understory dominated by the perennial bunchgrasses and slender wheatgrass (*Elymus trachycaulus*). The plant communities in State 1 are naturally resistant to disturbance and resilient following disturbance due to favorable amounts of precipitation and the ability of gambel oak to resprout following disturbance. Wildfire is the predominant disturbance affecting ecological processes and is the primary factor driving plant community change in this state. The common fire return interval is 35 to 100 years and plant recovery following a wildfire is rapid, often with Gambel oak resprouting within the same growing season.

#### Community Phase 1.1 Gambel oak / Perennial Bunchgrasses

This plant community consists of mature Gambel oak trees that dominate the overstory and wheatgrasses dominate the understory. Mountain brome, Geyer sedge, as well as other cool season grasses may be present. Common shrubs and forbs are Mountain snowberry, Saskatoon serviceberry, and a suite of other species adapted to grow either in the interspaces or under the canopy of Gambel oak stands. Bare ground is not common and no non-native plants are present.

Community Pathway 1.1a Wildfire --This pathway often occurs late in the growing season when precipitation is low and fuel load is at its peak. Gambel oak is at peak underground carbohydrate storage around this time of year, which provides the energy needed for resprouting.

Community Pathway 1.1b No Fire --This pathway is a subsequent step in natural succession that occurs when fire free periods approach their upper limits and allow fire sensitive species to encroach into Gambel oak sites.

#### Community Phase 1.2 Post-fire Community / Resprouting Gambel oak Thicket

This plant community consists of young Gambel oak shoots that are beginning to reestablish following a wildfire. Burned trunks will usually be visible above the new growth. The Gambel oak suckers often form dense thickets of foliage up to several feet in height which effectively intercept sunlight and crowd out potential invaders. Given adequate recovery time of a few months to a year, the interspaces will exhibit native bunchgrasses and forbs, but few shrubs.

Community Pathway 1.2a Natural Succession—As the post-fire community ages, Gambel oak becomes less dominant near the soil surface, but maintains its dominance in the canopy. Perennial grasses become more robust and the plant community becomes more diverse with the establishment of shrubs and shade sensitive species.

#### Community Phase 1.3 Encroachment by Other Tree Species

This plant community is comparable in composition to community 1.1 with the addition of fire sensitive tree species such as Douglas fir, and/or white fir. The presence of these tree species is scattered and relatively low.

Community Pathway 1.3a Wildfire-- This pathway often occurs late in the growing season when precipitation is low and fuel load is at its peak. Gambel oak also is at peak carbohydrate storage around this time of year, an adaptation which provides the energy needed to resprout and maintain its niche.

#### Transition 1-- Invasive Plants

Transition from Reference State (State 1) to current Potential State (State 2)

This transition occurs when non-native or invasive species become established in the plant community. Common invasive species include dalmatian toadflax, annual forbs, dandelion, houndstongue, rubber rabbitbrush, broom snakeweed, and cheatgrass. Intermediate wheatgrass, smooth brome, and Kentucky bluegrass may also spread into the site. Events that may facilitate the establishment of non-native plants are wildfire, introduction of livestock, seeding, and recreation.

#### Current Potential State (State 2)

State 2 is very similar to State 1 in form and function, with the exception of the presence of non-native plants and animals, possible extinctions of native species, and a different climate. State 2 is a description of the ecological site

shortly following Euro-American settlement.

#### Community Phase 2.1 Gambel oak / Slender wheatgrass

After a fire, Gambel oak sprouts vigorously and suppresses perennial grass and forb production. Non-native species are present, but not dominant.

Community Pathway 2.1a Wildfire -- This pathway often occurs late in the growing season when precipitation is low and fuel load is at its peak. Gambel oak is at peak underground carbohydrate storage around this time of year, which provides the energy needed for resprouting.

Community Pathway 2.1b No Fire -- This pathway is a subsequent step in natural succession that occurs when fire free periods approach their upper limits and allow fire sensitive species to encroach into Gambel oak sites.

Community Pathway 2.1c Prescribed Fire and Re-seed – This pathway occurs when land owners and/or land managers are attempting to improve the vigor of the native plant community.

Community Pathway 2.1d Continuous Heavy Grazing – This pathway occurs when improper grazing continues for extended periods of time not allowing for native plants to recover, ultimately lowering the health and vigor of these plants to compete with available resources.

#### Community Phase 2.2 Resprouting Gambel oak thicket

Gambel oak stem density is less than phase 1.1, though oak production may be higher. Non-native species are present, but not dominant.

#### Community Pathways

##### 2.2a Natural Succession on the site

#### Community Phase 2.3 Encroachment by other tree species

Phase 2.3 is characterized by encroachment of conifer species including Douglas fir, juniper and pinyon. Higher elevations of this ecological site are more susceptible to conifer encroachment. At lower elevations, this phase is characterized by decadent Gambel oak with patches of young sprouts. Gambel oak dies naturally around 80 years of age and promptly responds with vigorous young sprouts to replace the oak foliage. Native species are present, but not dominant

Community Pathway 2.3a Wildfire -- This pathway often occurs late in the growing season when precipitation is low and fuel load is at its peak. Gambel oak is at peak underground carbohydrate storage around this time of year, which provides the energy needed for resprouting.

Community Pathway 2.3b Brush Management (Fire) and reseedling – Utilization of techniques such as prescribed fire and range seeding can reduce composition of invading conifers as well as temporarily reduce competition from oak to allow for the herbaceous component to become established.

Community Pathway 2.3c Continuous Heavy Grazing -- This pathway occurs when improper grazing continues for extended periods of time not allowing for native herbaceous plants and shrubs to recover, ultimately lowering the health and vigor of these plants to compete with available resources.

#### Community Phase 2.4 Seeded Gambel oak Woodland

Phase 2.4 is an aerial seeding following fire. Both native and non-native perennial grasses and forbs are included in most seed mixes. Under proper grazing, native grass and forb species can outcompete introduced species and dominate the understory within 5 to 10 years.

Community Pathway 2.4a Wildfire -- This pathway often occurs late in the growing season when precipitation is low and fuel load is at its peak. Gambel oak is at peak underground carbohydrate storage around this time of year, which provides the energy needed for resprouting.

Community Pathway 2.4b Natural Succession/prescribed grazing – This pathway can occur through natural succession and prescribed grazing. Over time the oak will begin to be the dominant aspect on the site, and with proper grazing management the herbaceous understory and shrubs will maintain health and vigor on the site.

Community Pathway 2.4c Continuous Heavy Grazing -- This pathway occurs when improper grazing continues for extended periods of time not allowing for native herbaceous plants and shrubs to recover, ultimately lowering the health and vigor of these plants to compete with available resources.

Community Phase 2.5 Overgrazed Gambel oak

Phase 2.5 displays a reduction in the herbaceous understory and shrub component due to improper grazing and browsing from livestock and wildlife.

Community Pathway 2.5a No Fire – lack of fire over time will allow other tree species to naturally encroach into the site.

Community Pathway 2.5b Brush Management (Mechanical) and re-seeding -- utilization of techniques such as mechanical brush management and range seeding can reduce composition of oak to allow for the herbaceous component to become established.

Community Pathway 2.5c Natural succession and prescribed grazing – practicing prescribed grazing over time will allow the herbaceous and shrub components to become established on this site.

Transition 2 Noxious Weed Invasion / Repeated Wildfires

Transition from State 2 to State 3

Transition 3 Prescribed Grazing (Goats)

Transition from State 2 to State 4

State 3 Noxious Weed State

State 3 is characterized by a dominance of non-native noxious weeds. The threshold has been crossed into State 3 and the dynamics of this site will likely prohibit the return back into State 2 without an extraordinary amount of external inputs.

Community Phase 3.1 Broadleaf weed dominates interspaces

Native herbaceous species and shrubs have largely been replaced by prolific noxious weeds establishment which generally flourish in sites where there is a short fire return interval. This process makes it incredibly hard for native herbaceous species to become reestablished on the site. Gambel oak is able to remain on this site by utilizing available resources due to its extensive root system and its sprouting abilities following wildfire.

Community Pathway

3.1a Wildfire – The nature of this site with the abundance of noxious weeds and fine fuels shortens the fire return interval compared to the historic fire regime.

Community Phase 3.2 Weed co-dominant with resprouting Gambel oak

Following a wildfire, the herbaceous weed component and sprouting Gambel oak will dominate this site.

Community Pathway

3.2a Natural Succession – Due to the nature of this site, there is often a frequent fire return interval which will return this site back to Community Phase 3.1.

State 4: Herbaceous State:

Utilizing browsing animals such as goats, the threshold from State 2 is crossed into this State. Browsing animals will shift the competitive advantage to the herbaceous component leaving the site devoid of Gambel oak and dominated by the herbaceous understory.

Community Phase 4.1 Devoid of Gambel oak

**State and transition model**

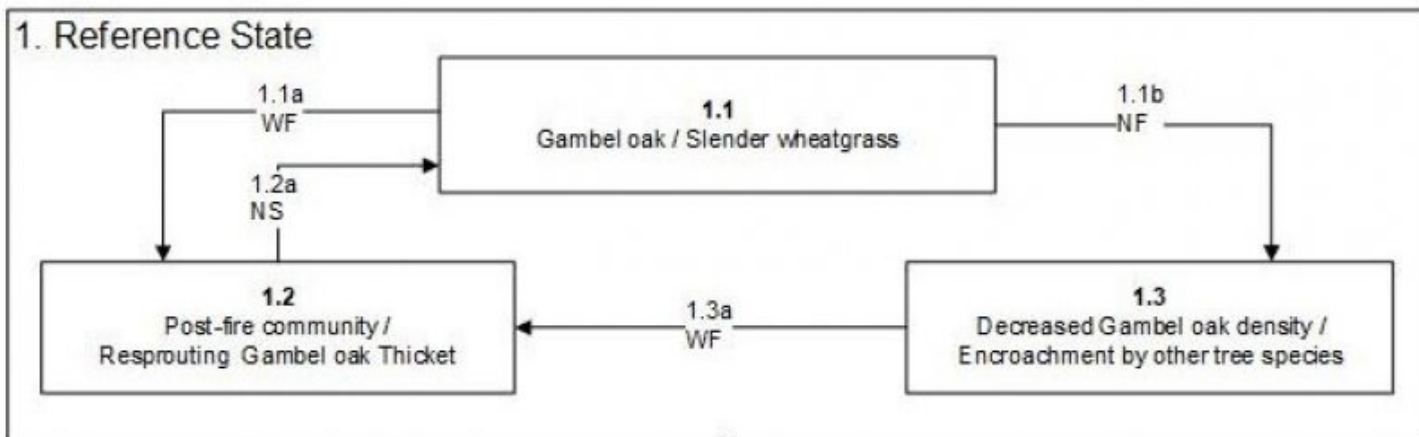

T1  
IP

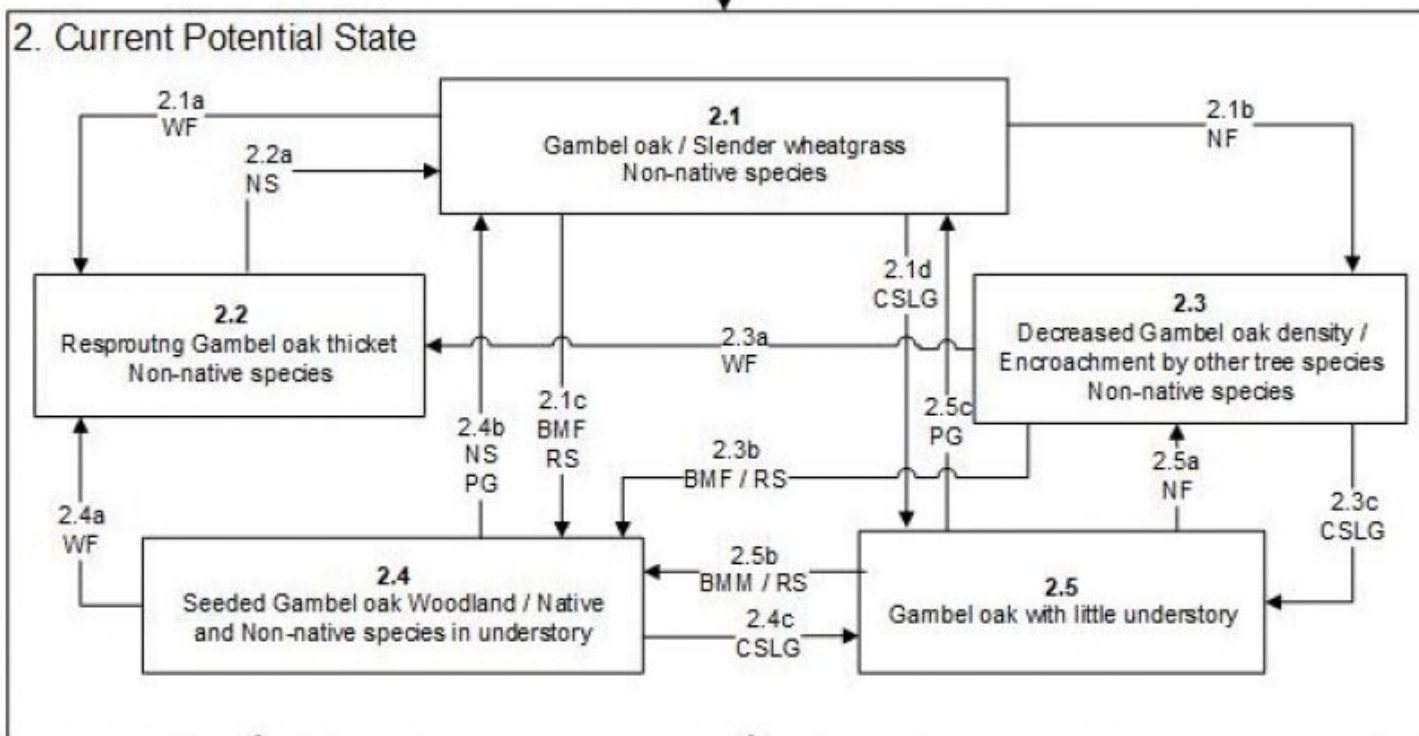

T2  
NWI / RWF

T3  
PG (Goats)

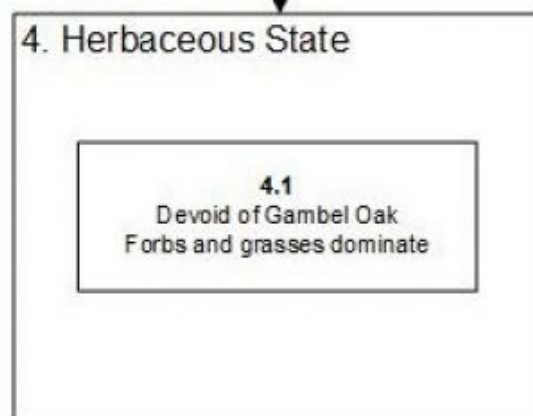
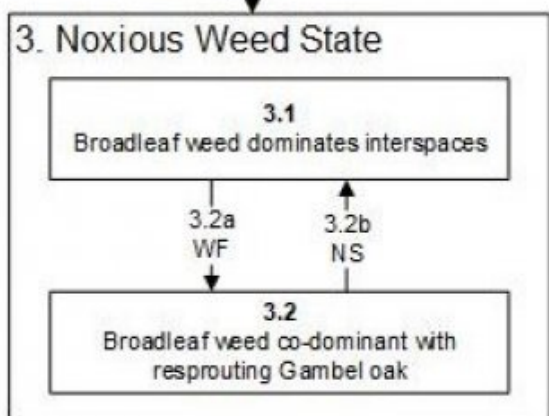

**Legend:** WF = Wildfire      NF = No Fire      BMM = Brush Management (Mechanical)  
 RS = Re-seeding      NS = Natural Succession      BMF = Brush Management (Fire)  
 PG = Prescribed Grazing      RWF = Recurring Wildfire      CSLG = Continuous Season-long Grazing  
 RPT = Replant Trees      IP = Introduced Species      NWI = Noxious Weed Invasion

## Inventory data references

Information presented here has been derived from NRCS clipping data and other inventory data. Field observations from range trained personnel were also used.

## Other references

Alexander, R. R. 1985. Major habitat types, community types, and plant communities in the Rocky Mountains. USDA- Forest Service Rocky Mountain Forest and Range Experiment Station. General technical report RM-123. 105p.

Alexander 1988. Forest vegetation on National Forests in the Rocky Mountain and Intermountain Regions: Habitat types and community types. USDA- Forest Service Rocky Mountain Forest and Range Experiment Station. General technical report RM-162. 47p.

Galatowitsch, S.M. 1990. Using the original land survey notes to reconstruct pre-settlement landscapes in the American West. Great Basin Naturalist: 50(2): 181-191. Keywords: [Western U.S., conservation, history, human impact]

Parson, R. E. 1996. A History of Rich County. Utah State Historical Society, County Commission, Rich County, Utah. Keywords: [Rich County, Utah, Historic land use, European settlements]

USDA-NRCS. 2003. National Range and Pasture Handbook. in USDA, editor, USDA-Natural Resources Conservation Service-Grazing Lands Technology Institute. Keywords: [Western US, Federal guidelines, Range pasture management]

Western Regional Climate Center, Western U.S. Climate Historical Summaries. Available at: <http://www.wrcc.dri.edu/summary/Climsmut.html>. Accessed 15 June 2009.

Web Soil Survey, Official Soil Series Descriptions. Available at: <http://soils.usda.gov/technical/classification/osd/index.html>. Accessed 15 June 2009.

## Contributors

M. Dean Stacy

## Approval

Sarah Quistberg, 2/11/2025

## Rangeland health reference sheet

Interpreting Indicators of Rangeland Health is a qualitative assessment protocol used to determine ecosystem condition based on benchmark characteristics described in the Reference Sheet. A suite of 17 (or more) indicators are typically considered in an assessment. The ecological site(s) representative of an assessment location must be known prior to applying the protocol and must be verified based on soils and climate. Current plant community cannot be used to identify the ecological site.

Author(s)/participant(s)	
Contact for lead author	
Date	02/26/2025
Approved by	Sarah Quistberg
Approval date	
Composition (Indicators 10 and 12) based on	Annual Production



## Indicators

1. **Number and extent of rills:**  

---
2. **Presence of water flow patterns:**  

---
3. **Number and height of erosional pedestals or terracettes:**  

---
4. **Bare ground from Ecological Site Description or other studies (rock, litter, lichen, moss, plant canopy are not bare ground):**  

---
5. **Number of gullies and erosion associated with gullies:**  

---
6. **Extent of wind scoured, blowouts and/or depositional areas:**  

---
7. **Amount of litter movement (describe size and distance expected to travel):**  

---
8. **Soil surface (top few mm) resistance to erosion (stability values are averages - most sites will show a range of values):**  

---
9. **Soil surface structure and SOM content (include type of structure and A-horizon color and thickness):**  

---
10. **Effect of community phase composition (relative proportion of different functional groups) and spatial distribution on infiltration and runoff:**  

---
11. **Presence and thickness of compaction layer (usually none; describe soil profile features which may be mistaken for compaction on this site):**  

---
12. **Functional/Structural Groups (list in order of descending dominance by above-ground annual-production or live foliar cover using symbols: >>, >, = to indicate much greater than, greater than, and equal to):**

Dominant:

Sub-dominant:

Other:

Additional:

---

13. **Amount of plant mortality and decadence (include which functional groups are expected to show mortality or decadence):**
- 

14. **Average percent litter cover (%) and depth ( in):**
- 

15. **Expected annual annual-production (this is TOTAL above-ground annual-production, not just forage annual-production):**
- 

16. **Potential invasive (including noxious) species (native and non-native). List species which BOTH characterize degraded states and have the potential to become a dominant or co-dominant species on the ecological site if their future establishment and growth is not actively controlled by management interventions. Species that become dominant for only one to several years (e.g., short-term response to drought or wildfire) are not invasive plants. Note that unlike other indicators, we are describing what is NOT expected in the reference state for the ecological site:**
- 

17. **Perennial plant reproductive capability:**
-