

Ecological site R047XC008UT Wet Fresh Meadow (sedge)

Last updated: 2/11/2025
Accessed: 02/26/2025

General information

Provisional. A provisional ecological site description has undergone quality control and quality assurance review. It contains a working state and transition model and enough information to identify the ecological site.

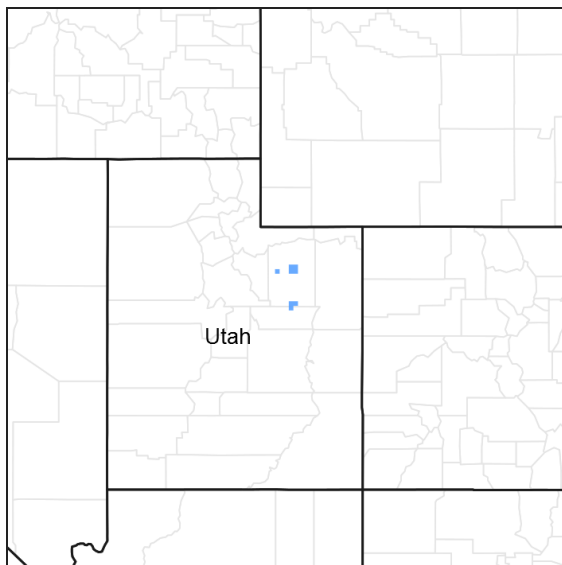

Figure 1. Mapped extent

Areas shown in blue indicate the maximum mapped extent of this ecological site. Other ecological sites likely occur within the highlighted areas. It is also possible for this ecological site to occur outside of highlighted areas if detailed soil survey has not been completed or recently updated.

MLRA notes

Major Land Resource Area (MLRA): 047X–Wasatch and Uinta Mountains

MLRA 47 occurs in Utah (86 percent), Wyoming (8 percent), Colorado (4 percent), and Idaho (2 percent). It encompasses approximately 23,825 square miles (61,740 square kilometers). The northern half of this area is in the Middle Rocky Mountains Province of the Rocky Mountain System. The southern half is in the High Plateaus of the Utah Section of the Colorado Plateaus Province of the Intermontane Plateaus. Parts of the western edge of this MLRA are in the Great Basin Section of the Basin and Range Province of the Intermontane Plateaus. The MLRA includes the Wasatch Mountains, which trend north and south, and the Uinta Mountains, which trend east and west. The steeply sloping, precipitous Wasatch Mountains have narrow crests and deep valleys. Active faulting and erosion are a dominant force in controlling the geomorphology of the area. The Uinta Mountains have a broad, gently arching, elongated shape. Structurally, they consist of a broadly folded anticline that has an erosion-resistant quartzite core. The Wasatch and Uinta Mountains have an elevation of 4,900 to about 13,500 feet (1,495 to 4,115 meters).

The mountains in this area are primarily fault blocks that have been tilted up. Alluvial fans at the base of the mountains are recharge zones for the basin fill aquifers. An ancient shoreline of historic Bonneville Lake is evident on the footholes along the western edge of the area. Rocks exposed in the mountains are mostly Mesozoic and Paleozoic sediments, but Precambrian rocks are exposed in the Uinta Mountains. The Uinta Mountains are one of the few ranges in the United States that are oriented west to east. The southern Wasatch Mountains consist of

Tertiary volcanic rocks occurring as extrusive lava and intrusive crystalline rocks.

The average precipitation is from 8 to 16 inches (203 to 406 mm) in the valleys and can range up to 73 inches (1854 mm) in the mountains. In the northern and western portions of the MLRA, peak precipitation occurs in the winter months. The southern and eastern portions have a greater incidence of high-intensity summer thunderstorms; hence, a significant amount of precipitation occurs during the summer months. The average annual temperature is 30 to 50 degrees Fahrenheit (-1 to 15 C). The freeze-free period averages 140 days and ranges from 60 to 220 days, generally decreasing in length with elevation.

The dominant soil orders in this MLRA are Aridisols, Entisols, Inceptisols, and Mollisols. The lower elevations are dominated by a frigid temperature regime, while the higher elevations experience cryic temperature regimes. Mesic temperature regimes come in on the lower elevations and south facing slopes in the southern portion of this MLRA. The soil moisture regime is typically xeric in the northern part of the MLRA, but grades to ustic in the extreme eastern and southern parts. The mineralogy is generally mixed and the soils are very shallow to very deep, generally well drained, and loamy or loamy-skeletal.

LRU notes

E47C is the Uinta Mountains portion of MLRA 47 that run east and west which includes the Uinta Wilderness and The Flaming Gorge National Recreation Area and towns such as Evanston, Wyoming, Hanna and Tabiona, Utah. Structurally these mountains consist of a broadly folded anticline that has an erosion resistance quartzite core. The Duchesne River and many other tributaries to the Green River run through this range, as well as the headwaters of the Bear River.

Ecological site concept

The soil is deep to very deep with a dark (mollic) surface horizon. It formed in valley fill over glacial outwash derived mainly from Uinta Mountain group sandstone and quartzite. The surface texture is fine sandy loam to loam. Available water capacity is 6 to 8 inches in the top 60 inches. The water table is between 4 and 20 inches of the soil surface during the plant growing period. The soil temperature regime is frigid and the soil moisture regime is ustic.

Associated sites

R047XC004UT	Semi-wet Fresh Meadow
R047XC430UT	Mountain Loam (mountain big sagebrush)

Similar sites

R047XC004UT	Semi-wet Fresh Meadow
-------------	------------------------------

Table 1. Dominant plant species

Tree	Not specified
Shrub	Not specified
Herbaceous	(1) <i>Carex nebrascensis</i> (2) <i>Carex aquatilis</i>

Physiographic features

Fan remnant and flood-plain step.

Table 2. Representative physiographic features

Landforms	(1) Fan remnant (2) Flood-plain step
Flooding duration	Very brief (4 to 48 hours) to long (7 to 30 days)

Flooding frequency	None to frequent
Elevation	6,400–8,000 ft
Slope	2–10%
Water table depth	0–20 in
Aspect	Aspect is not a significant factor

Climatic features

The climate is characterized by cool, moist summers and cold, snowy winters. Approximately 55 percent of the precipitation occurs as rain from April through September. On the average, October, November, and December are the driest months and April, May, and June are the wettest months because of flooding associated with spring runoff.

Table 3. Representative climatic features

Frost-free period (characteristic range)	30-50 days
Freeze-free period (characteristic range)	
Precipitation total (characteristic range)	12-20 in

Influencing water features

The water table is between 0 and 20 inches of the soil surface during the plant growing period.

Wetland description

Further review is required.

Soil features

The soil is deep to very deep with a dark (mollic) surface horizon. It formed in valley fill over glacial outwash derived mainly from Uinta Mountain group sandstone and quartzite. The surface texture is fine sandy loam to loam. Available water capacity is 6 to 8 inches in the top 60 inches. The soil temperature regime is frigid and the soil moisture regime is ustic.

Modal Soil: Enochville Family SiL 0-2% — fine-silty, mixed Cumulic Cryoborolls

Table 4. Representative soil features

Parent material	(1) Alluvium–sandstone (2) Alluvium–quartzite
Surface texture	(1) Fine sandy loam (2) Loam
Family particle size	(1) Fine-loamy (2) Fine-silty
Drainage class	Well drained
Permeability class	Moderately slow to moderate
Depth to restrictive layer	60–80 in
Soil depth	60–80 in
Available water capacity (20-40in)	6–8 in

Calcium carbonate equivalent (20-40in)	0–5%
Electrical conductivity (20-40in)	0–2 mmhos/cm
Sodium adsorption ratio (20-40in)	0–3
Soil reaction (1:1 water) (20-40in)	7.4–8.2
Subsurface fragment volume <=3" (20-40in)	0%
Subsurface fragment volume >3" (20-40in)	0%

Ecological dynamics

It is impossible to determine in any quantitative detail the Historic Climax Plant Community (HCPC) for this ecological site because of the lack of direct historical documentation preceding all human influence. In some areas, the earliest reports of dominant plants include the cadastral survey conducted by the General Land Office, which began in the late 19th century for this area (Galatowitsch 1990). However, up to the 1870s the Shoshone Indians, prevalent in northern Utah and neighboring states, grazed horses and set fires to alter the vegetation for their needs (Parson 1996). In the 1860s, Europeans brought cattle and horses to the area, grazing large numbers of them on unfenced parcels year-long (Parson 1996). Itinerant and local sheep flocks followed, largely replacing cattle as the browse component increased.

Below is a State and Transition Model diagram to illustrate the “phases” (common plant communities), and “states” (aggregations of those plant communities) that can occur on the site. Differences between phases and states depend primarily upon observations of a range of disturbance histories in areas where this ESD is represented. These situations include grazing gradients to water sources, fence-line contrasts, patches with differing dates of fire, herbicide treatment, tillage, etc. Reference State 1 illustrates the common plant communities that probably existed just prior to European settlement.

The major successional pathways within states, (“community pathways”) are indicated by arrows between phases. “Transitions” are indicated by arrows between states. The drivers of these changes are indicated in codes decipherable by referring to the legend at the bottom of the page and by reading the detailed narratives that follow the diagram. The transition between Reference State 1 and State 2 is considered irreversible because of the naturalization of exotic species of both flora and fauna, possible extinction of native species, and climate change. There may have also been accelerated soil erosion.

When available, monitoring data (of various types) were employed to validate more subjective inferences made in this diagram. See the complete files in the office of the State Range Conservationist for more details.

The plant communities shown in this State and Transition Model may not represent every possibility, but are probably the most prevalent and recurring plant communities. As more monitoring data are collected, some phases or states may be revised, removed, and/or new ones may be added. None of these plant communities should necessarily be thought of as “Desired Plant Communities.” According to the USDA NRCS National Range & Pasture Handbook (USDA-NRCS 2003), Desired Plant Communities (DPC’s) will be determined by the decision-makers and will meet minimum quality criteria established by the NRCS. The main purpose for including descriptions of a plant community is to capture the current knowledge at the time of this revision.

State and transition model

R047CY008UT: Interzonal – Wet Fresh Meadow (Sedge)



T3a
(Till; RS)

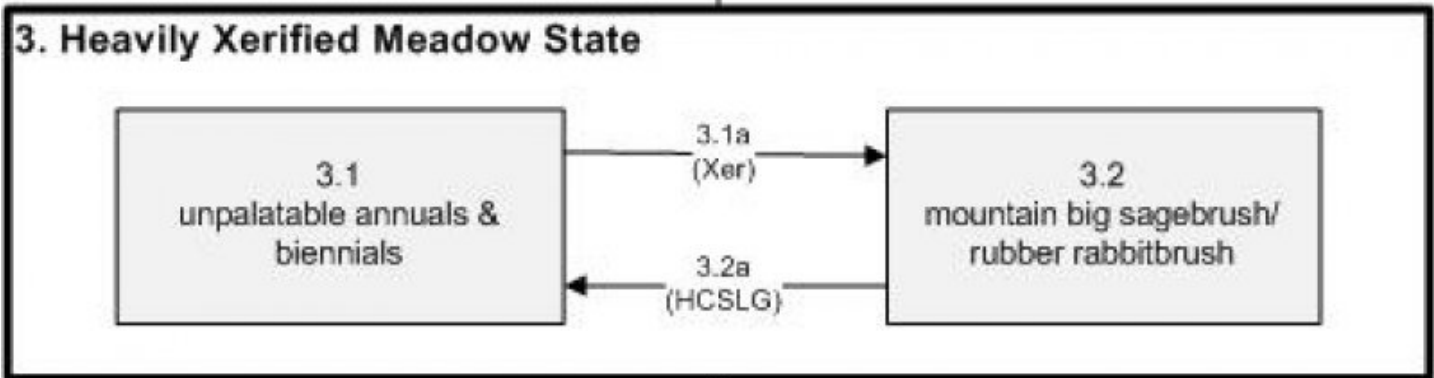

T2a
(Log/Ch; Xer;
HCSLG)

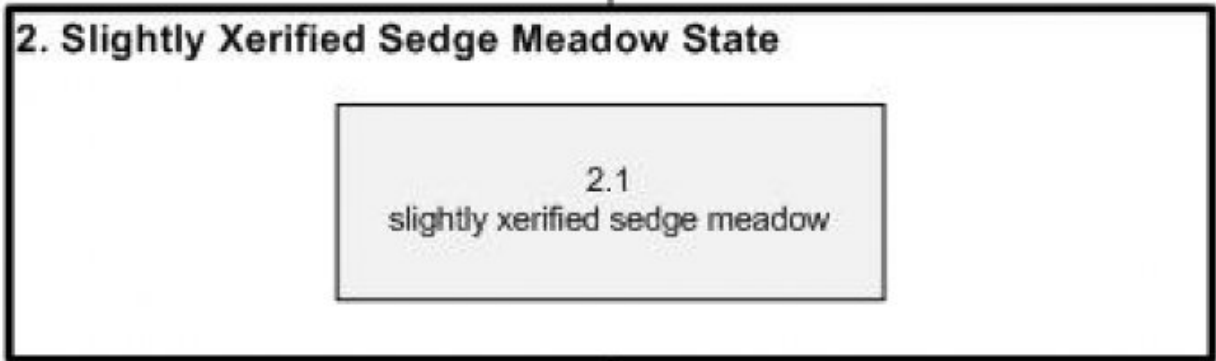

T1a
(HC;
Log/Ch; Xer;
HCSLG)

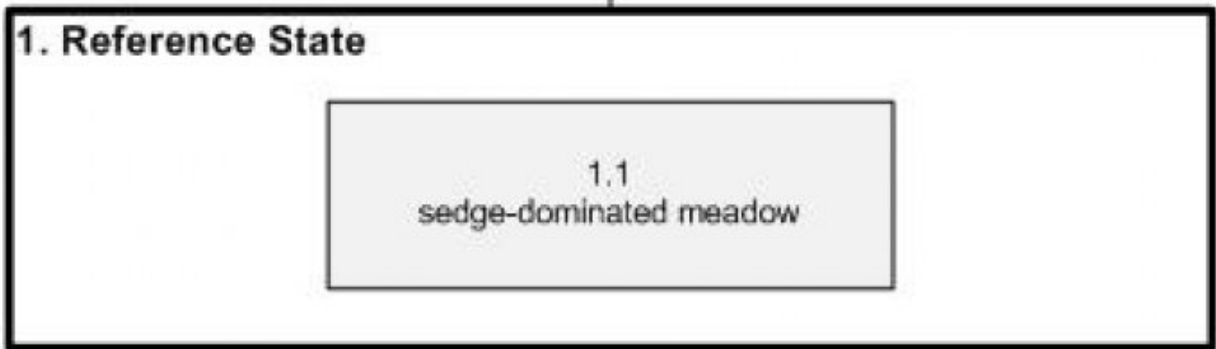

Ch	Channelization (down-cutting)
HC	Historic Change
HCSLG	Heavy Continuous Season Long Grazing
Log	Logging (of sites higher in watershed)
RS	Re-seeding
Till	Tillage
Xer	Xerification

Figure 2. State and Transition Model

State 1 Reference State

The Reference State is a description of this ecological site just prior to Euro-American settlement but long after the arrival of Native Americans. The description of the Reference State was determined by NRCS Soil Survey Type Site Location information and familiarity with rangeland relict areas where they exist. The least modified plant community (1.1) within the Reference State would have been a fen (i.e. a wet grassland) dominated by sedges including Nebraska sedge (*Carex nebrascensis*), water sedge (*Carex aquatilis*), and smallwing sedge (*Carex microptera*), rushes including mountain rush (*Juncus arcticus* ssp. littoralis) and fewflower spikerush (*Eleocharis quinqueflora*), and grasses including tufted hairgrass (*Deschampsia cespitosa*), alpine timothy (*Phleum alpinum*), marsh bluegrass (*Poa leptocoma*), and slender wheatgrass (*Elymus trachycaulus*). Minor amounts of forbs and shrubs would have also occurred. A more complete list of species by lifeform for the Reference State is available in accompanying tables in the “Plant Community Composition by Weight and Percentage” section of this document. The productivity and composition of this plant community would have been quite stable, although varying with the climate because it would have been affected by runoff from streams originating at higher elevations in adjacent mountains. The water table usually persisted throughout the year, causing poorly-aerated soils. Following very wet winters, the melting snow pack would have caused a high and widespread surge of flooding.

Community 1.1 Reference Plant Community

Community Phase 1.1: sedge-dominated meadow The Reference State would have been a meadow dominated by several species of sedge including Nebraska sedge, water sedge, and smallwing sedge. Some rushes (mountain rush and fewflower spikerush) and grass species (tufted hairgrass, alpine timothy, marsh bluegrass, and slender wheatgrass) would have also been present.

Table 5. Annual production by plant type

Plant Type	Low (Lb/Acre)	Representative Value (Lb/Acre)	High (Lb/Acre)
Grass/Grasslike	3105	4454	5804
Forb	173	248	323
Shrub/Vine	173	248	323
Total	3451	4950	6450

Table 6. Ground cover

Tree foliar cover	0%
Shrub/vine/liana foliar cover	0-2%
Grass/grasslike foliar cover	89-91%
Forb foliar cover	4-6%
Non-vascular plants	0%
Biological crusts	0%

Litter	0%
Surface fragments >0.25" and <=3"	0%
Surface fragments >3"	0%
Bedrock	0%
Water	0%
Bare ground	0%

Table 7. Canopy structure (% cover)

Height Above Ground (Ft)	Tree	Shrub/Vine	Grass/ Grasslike	Forb
<0.5	–	–	–	–
>0.5 <= 1	–	–	–	4-6%
>1 <= 2	–	–	89-94%	–
>2 <= 4.5	–	–	–	–
>4.5 <= 13	–	–	–	–
>13 <= 40	–	–	–	–
>40 <= 80	–	–	–	–
>80 <= 120	–	–	–	–
>120	–	–	–	–

State 2

Slightly Xerified Sedge Meadow State

State 2 is similar to State 1 in form and function, with the exception of the presence of non-native plants and animals, possible extinctions of native species, and a different climate. State 2 is a description of the ecological site shortly following Euro-American settlement. This state can be regarded as the current potential. Although similar to State 1 in form and function, soon after European colonization, this xerified state saw reductions in the proportion of the finer-textured soils, and thus a decrease in the more palatable, grasses and increases in the coarser sedges and rushes. Because the soils are somewhat drier due to changes in the hydrologic regime, expansion of native shrubs such as Geyer willow (*Salix geyeriana*), Woods' rose (*Rosa woodsii*), and cinquefoil (*Potentilla* spp.) began. In areas first targeted by the U.S. Forest Service for grazing control (circa 1910), the herbaceous fraction usually regained its dominance and slowed down the advance of the shrubs. An increase in moose and beaver also put pressure on the willows. Newly constructed beaver dams simultaneously increased ponding and raised water tables in and around streams.

Community 2.1

Slightly Xerified Sedge Meadow Plant Community

This plant community is dominated by the less palatable sedges and rushes with patches of native shrubs including Geyer willow, Woods' rose, and cinquefoil.

State 3

Heavily Xerified Meadow State

Where control of grazing intensity hadn't been achieved earlier and excessive use by livestock prevailed, the vegetation takes on the character of drier sites at low elevations. Upland species such as rubber rabbitbrush (*Ericameria nauseosa*) and mountain big sagebrush (*Artemisia tridentata* ssp. *vaseyana*), common on drier adjacent sites, begin to dominate (3.2). The areas most heavily affected from livestock grazing and loafing (3.2a) will be reduced to only those annual and biennial species most tolerant to disturbance (3.1).

Community 3.1

Unpalatable Annuals & Biennials Plant Community

Community Phase 3.1: unpalatable annuals & biennials This plant community is dominated by a mixture of native and introduced annuals and biennials such as Douglas' knotweed (*Polygonum douglasii*), mountain tarweed (*Madia glomerata*), common dandelion (*Taraxacum officinale*), curlycup gumweed (*Grindelia squarrosa*), povertyweed (*Iva axillaris*), and Fuller's teasel (*Dipsacus fullonum*). Disturbance has been so frequent and heavy that long-lived plants have no chance to become dominant. This vegetation will persist until impacts are diminished.

Community 3.2

Mountain big sagebrush/ rubber rabbitbrush Plant Community

Community Phase 3.2: mountain big sagebrush/ rubber rabbitbrush With a lessening of the frequency and intensities of disturbance, shrubs that dominate adjacent drier sites can invade the site and become dominant. Rubber rabbitbrush is an early invader; however mountain big sagebrush will eventually come to dominate.

Pathway 3.1a

Community 3.1 to 3.2

Previous channelization and consequent lowering of the water table will over time lead to xerification of this site. This occurs due to changes in the hydrologic and soil moisture regimes and allows shrubs to become more dominant.

Pathway 3.2a

Community 3.2 to 3.1

Heavy and frequent disturbance over a prolonged period of time will convert the site to one dominated by shorter-lived and unpalatable forb species.

State 4

Replacement Grassland State

Grasses used to reseed degraded montane meadows include meadow foxtail, tall oatgrass (*Arrhenatherum elatius*), mountain brome (*Bromus marginatus*), orchardgrass (*Dactylis glomerata*), tufted hairgrass, sheep fescue (*Festuca ovina*), meadow barley (*Hordeum brachyantherum*), and timothy (*Phleum pratense*) (4.1). Smooth brome (*Bromus inermis*) was commonly seeded in the past, but should be avoided because of its invasive nature. No matter the seed mix used, there will be some seed remaining in the tilled soil and subsequent climate and management will mold the species occurring at particular times. These variables make it impossible to anticipate the phases that will develop. Monitor changes and regulate use to favor the species combinations desired.

Community 4.1

Replacement Grassland Plant Community

Community Phase 4.1: seeded grassland This plant community is dominated by a suite of seeded montane grass species used to increase forage production for livestock. A combination of any of the following species may be present: meadow foxtail, tall oatgrass, California brome, meadow brome, mountain brome, smooth brome, orchardgrass, tufted hairgrass, sheep fescue, meadow barley, and timothy.

Transition T1a

State 1 to 2

Transition from State 1 to State 2 (Reference State to Slightly Xerified Sedge Meadow State) The simultaneous introduction of exotic species, both plants and animals, and possible extinctions of native flora and fauna, along with climate change, impacted the Reference State. However, it was primarily the heavy logging and livestock grazing in the watersheds above that changed the environment in this ESD. Those activities led to earlier and higher floods following snowmelt. These waters also carried more sediment and caused more rapid down-cutting of the stream courses. This lowered the water table and shortened the period of soil saturation. Direct livestock utilization disfavored the fine textured grasses and grass-like, allowing an increase in the proportion of sedges and rushes with higher silica content. Reversal of these historic changes (i.e. a return pathway back to State 1) is not practical.

Transition T2a

State 2 to 3

T2a: Transition from State 2 to State 3 (Slightly Xerified Sedge Meadow State to Heavily Xerified Meadow State) These meadows are indirectly affected by the logging and livestock grazing pressures that occur in forested areas higher in the watershed. Where heavy logging and livestock grazing is not controlled, flash-flooding results, causing an increase in sediment-loads down the connecting streams. Streambanks are down-cut, causing the flow of water through these lower montane meadows to increase. Where heavy grazing pressure continues directly on these drying meadows, further xerification results these sites becoming invaded by both native and introduced species tolerant of drier soils and greater disturbance. The approach to this transition is indicated by the occurrence of seedlings of species dominant on drier sites, by areas of frequent disturbance, and by reduced ground cover.

Transition T3a

State 3 to 4

Transition from State 3 to State 4 (Heavily Xerified Meadow State to Replacement Grassland State) This transition is triggered by management decisions and actions. Because forage production is so diminished from earlier States and the hydrological regime so modified, it is impractical to reseed with species present in the Reference State or State 2. Thus, it has been common to till and re-seed with introduced species to regain a higher level of ground cover and forage production.

Additional community tables

Table 8. Community 1.1 plant community composition

Group	Common Name	Symbol	Scientific Name	Annual Production (Lb/Acre)	Foliar Cover (%)
Grass/Grasslike					
1	Dominant Grasses and Grasslikes			3250–4500	
	Nebraska sedge	CANE2	<i>Carex nebrascensis</i>	1000–1250	–
	water sedge	CAAQ	<i>Carex aquatilis</i>	1000–1250	–
	tufted hairgrass	DECE	<i>Deschampsia cespitosa</i>	750–1000	–
	smallwing sedge	CAMI7	<i>Carex microptera</i>	250–500	–
	mountain rush	JUARL	<i>Juncus arcticus ssp. littoralis</i>	250–500	–
2	Sub-Dominant Grasses and Grasslikes			2650–4000	
	Grass, perennial	2GP	<i>Grass, perennial</i>	750–1000	–
	Grass, annual	2GA	<i>Grass, annual</i>	750–1000	–
	alpine timothy	PHAL2	<i>Phleum alpinum</i>	150–250	–
	marsh bluegrass	POLE2	<i>Poa leptocoma</i>	150–250	–
	tule	SCACO2	<i>Schoenoplectus acutus var. occidentalis</i>	150–250	–
	fewflower spikerush	ELQU2	<i>Eleocharis quinqueflora</i>	150–250	–
	slender wheatgrass	ELTR7	<i>Elymus trachycaulus</i>	150–250	–
Forb					
3	Sub-Dominant Forbs			850–1600	
	Forb, perennial	2FP	<i>Forb, perennial</i>	150–250	–
	Forb, annual	2FA	<i>Forb, annual</i>	150–250	–
	alpine leafybract aster	SYFO2	<i>Symphotrichum foliaceum</i>	50–100	–
	heartleaf bittercress	CACO6	<i>Cardamine cordifolia</i>	50–100	–
	white marsh marigold	CALE4	<i>Caltha leptosepala</i>	50–100	–
	wild mint	MEAR4	<i>Mentha arvensis</i>	50–100	–
	elephanthead lousewort	PEGR2	<i>Pedicularis groenlandica</i>	50–100	–
	Tweedy's plantain	PLTW	<i>Plantago tweedyi</i>	50–100	–
	graceful buttercup	RAIN	<i>Ranunculus inamoenus</i>	50–100	–
	water ragwort	SEHY2	<i>Senecio hydrophilus</i>	50–100	–
	longstalk clover	TRLO	<i>Trifolium longipes</i>	50–100	–
	seaside arrowgrass	TRMA20	<i>Triglochin maritima</i>	50–100	–
	hookedspur violet	VIAD	<i>Viola adunca</i>	50–100	–
Shrub/Vine					
4	Sub-Dominant Shrubs			150–350	
	Shrub (>.5m)	2SHRUB	<i>Shrub (>.5m)</i>	150–250	–
	shrubby cinquefoil	DAFRF	<i>Dasiphora fruticosa ssp. floribunda</i>	50–150	–
	Woods' rose	ROWO	<i>Rosa woodsii</i>	50–150	–
	Geyer willow	SAGE2	<i>Salix geyeriana</i>	50–150	–

Animal community

This is one of Utah's highest yielding ecological sites. The plants are predominantly grasses and grasslike plants with a few forbs and practically no shrubs. To control soil erosion and deterioration of the plant community, this site may be properly grazed early with animals being removed early to allow key plants to go ungrazed during the last

part of the growing season. A stubble height of 4 to 6 inches should be adhered to.

The potential is poor to fair for openland habitat, good to fair for woodland habitat, good to fair for wetland habitat dependent on slope, and poor to fair for rangeland wildlife habitat.

It is good all around habitat for waterfowl and shorebirds, muskrats, and beaver wherever it is adjacent to streams and ponds. It is fair for upland game, birds, and songbirds. It provides some feed for moose, elk, and deer and brood rearing areas for sage grouse.

Hydrological functions

Soil series in this site are grouped mainly into D hydrologic group. These soils have high runoff potential. When the vegetation is in climax, the hydrologic curves are from 84 to 85. Refer to National Engineering Handbook Section 4 (USDA - NRCS), to determine runoff quantities from these curves. When range condition has declined from the climax, field investigations are needed in order to determine hydrologic curve numbers. Use form UT-range-2 for this purpose.

Recreational uses

This site presents a view of lush, high producing vegetation primarily grasses and grasslike plants. It presents a pleasing view, especially when livestock or big game are grazing it – one of a pleasant pastoral panorama. Fishing is opportune in adjacent lakes and streams.

Wood products

None

Inventory data references

Information presented here has been derived from NRCS clipping data and other inventory data. Field observations from range trained personnel were also used.

Other references

Galatowitsch, S.M. 1990. Using the original land survey notes to reconstruct pre-settlement landscapes in the American West. *Great Basin Naturalist*: 50(2): 181-191. Keywords: [Western U.S., conservation, history, human impact]

Parson, R. E. 1996. *A History of Rich County*. Utah State Historical Society, County Commission, Rich County, Utah. Keywords: [Rich County, Utah, Historic land use, European settlements]

USDA-NRCS. 2003. *National Range and Pasture Handbook*. in USDA, editor, USDA-Natural Resources Conservation Service-Grazing Lands Technology Institute. Keywords: [Western US, Federal guidelines, Range pasture management]

Contributors

Garth W. Leishman, Lars L. Rassmussen

Approval

Sarah Quistberg, 2/11/2025

Rangeland health reference sheet

Interpreting Indicators of Rangeland Health is a qualitative assessment protocol used to determine ecosystem condition based on benchmark characteristics described in the Reference Sheet. A suite of 17 (or more) indicators are typically considered in an assessment. The ecological site(s) representative of an assessment location must be

known prior to applying the protocol and must be verified based on soils and climate. Current plant community cannot be used to identify the ecological site.

Author(s)/participant(s)	V. Keith Wadman, NRCS Retired.
Contact for lead author	shane.green@ut.usda.gov
Date	10/17/2012
Approved by	Sarah Quistberg
Approval date	
Composition (Indicators 10 and 12) based on	Annual Production

Indicators

- 1. Number and extent of rills:** None. A very slight amount of rill development may be observed following large storm events or spring runoff periods, but they should heal within the following growing season. Very slight rill development may also be observed where the site is adjacent to ecological sites that produce large amounts of runoff (i.e. steep sites, slickrock, etc.).

- 2. Presence of water flow patterns:** None to rare. Any flow patterns present should be sinuous and wind around perennial plant bases. They should be short (4 to 8 feet), < 6" wide, and spaced from 10 to 15 feet apart. They should be stable with only minor evidence of deposition. This site is periodically inundated with runoff water from adjacent sites. It also acts as a filter and trap sediment.

- 3. Number and height of erosional pedestals or terracettes:** None to rare. A few plants may show very minor pedestalling where they are adjacent to any water flow patterns present, but there will be no exposed roots. Terracettes are not present.

- 4. Bare ground from Ecological Site Description or other studies (rock, litter, lichen, moss, plant canopy are not bare ground):** 0 to 5% bare ground. Any bare ground openings present should be < 1 foot in size and should not be connected.

- 5. Number of gullies and erosion associated with gullies:** None at site level. Widely scattered landscape level gully channels, however, are a normal component of desert environments. Where landscape gullies are present, they should be stable, vegetated on both sides and bottoms, with no evidence of head-cutting. Some slight increase in disturbance may be evident following significant weather events or when gullies convey considerable runoff from higher elevation rocky or naturally eroding areas.

- 6. Extent of wind scoured, blowouts and/or depositional areas:** No evidence of wind generated soil movement. Wind scoured (blowouts) and depositional areas are not present.

- 7. Amount of litter movement (describe size and distance expected to travel):** The majority of litter accumulates in place at the base of plant canopies. Slight movement of the finest material (< 1/4 inch) may move 1 to 2 feet downslope when transported by water. Little accumulation is observed behind obstructions.

-
8. **Soil surface (top few mm) resistance to erosion (stability values are averages - most sites will show a range of values):** This site should have a soil stability rating of 6 under plant canopies and a rating of 5 to 6 in any interspaces present. The average should be 6. Surface textures typically vary from silt loams and silty clay loams to clay loams.
-
9. **Soil surface structure and SOM content (include type of structure and A-horizon color and thickness):**
(Enochville) Soil surface is typically 0 to 7 inches deep. Surface texture is a silt loam which will often have a thin organic root-mat on the surface, structure is strong medium and fine granular. The A-horizon color is black, 10YR 2/1). Soils have an Mollic epipedon that extends 20 to 45 inches into the soil profile. Use the specific information for the soil you are assessing found in the published soil survey to supplement this description.
-
10. **Effect of community phase composition (relative proportion of different functional groups) and spatial distribution on infiltration and runoff:** Perennial vegetation breaks raindrop impact and reduces splash erosion. Dense distribution of plants slows runoff by obstructing surface flows, allowing time for increased infiltration. With the physiographic location of this site being in low lying areas, it often acts as a terminal accumulation site for runoff. The amount of sodium in the soil can affect infiltration and facilitate puddling on the surface.
-
11. **Presence and thickness of compaction layer (usually none; describe soil profile features which may be mistaken for compaction on this site):** None. This site will normally have textural changes within its' profile. These should not be mistaken for compaction layers.
-
12. **Functional/Structural Groups (list in order of descending dominance by above-ground annual-production or live foliar cover using symbols: >>, >, = to indicate much greater than, greater than, and equal to):**
- Dominant: Perennial Grasses and grass-likes (Nebraska sedge, leafy tussock sedge, tufted hairgrass) > Perennial Forbs (alpine aster, longstock clover).
- Sub-dominant: Shrubs (Geyer willow, woods rose) > Rhizomatous Grasses and grasslikes (arctic rush, smallwing sedge) >> Perennial Forbs (field mint).
- Other: Functional/structural groups may appropriately contain non-native species if their ecological function is the same as the native species in the reference state. Biological soil crust is variable in its' expression where present on this site and is measured as a component of ground cover. Perennial and annual forbs can be expected to vary widely in their expression in the plant community based upon departures from average growing conditions.
- Additional: Disturbance regimes include insects, infrequent fire, and flooding. Temporal variability can be caused by fires, droughts, insects, etc. Spatial variability can be caused by runoff, soil pH, and topography.
-
13. **Amount of plant mortality and decadence (include which functional groups are expected to show mortality or decadence):** During years with average to above average precipitation, there should be no mortality or decadence in either perennial grasses or grasslikes. During severe (multi-year) droughts that affect groundwater levels, up to 10% of the perennial plants may die. There may be partial mortality of individual grasses and grasslikes during less severe droughts.
-

14. **Average percent litter cover (%) and depth (in):** Litter cover ranges from 60 to 70%. Depth should be 1 inch thickness in any interspaces and from 2 to 3 inches under perennial plant canopies.

15. **Expected annual annual-production (this is TOTAL above-ground annual-production, not just forage annual-production):** Annual production in air-dry herbage should be approximately 4900 to 5000 pounds per acre on an average year. Production could vary from 3400 to 6500 pounds per acre during drought or above-average years.

16. **Potential invasive (including noxious) species (native and non-native). List species which BOTH characterize degraded states and have the potential to become a dominant or co-dominant species on the ecological site if their future establishment and growth is not actively controlled by management interventions. Species that become dominant for only one to several years (e.g., short-term response to drought or wildfire) are not invasive plants. Note that unlike other indicators, we are describing what is NOT expected in the reference state for the ecological site:** Phragmites, bullrush, Canada thistle, whitetop, mustard species and other non-native forbs and grasses.

17. **Perennial plant reproductive capability:** All perennial plants should have the ability to reproduce sexually or asexually in most years, except in drought years.
