

## Ecological site R047XC016UT Loamy Bottom (basin big sagebrush)

Last updated: 2/11/2025  
Accessed: 02/26/2025

---

### General information

**Provisional.** A provisional ecological site description has undergone quality control and quality assurance review. It contains a working state and transition model and enough information to identify the ecological site.

### MLRA notes

Major Land Resource Area (MLRA): 047X–Wasatch and Uinta Mountains

MLRA 47 occurs in Utah (86 percent), Wyoming (8 percent), Colorado (4 percent), and Idaho (2 percent). It encompasses approximately 23,825 square miles (61,740 square kilometers). The northern half of this area is in the Middle Rocky Mountains Province of the Rocky Mountain System. The southern half is in the High Plateaus of the Utah Section of the Colorado Plateaus Province of the Intermontane Plateaus. Parts of the western edge of this MLRA are in the Great Basin Section of the Basin and Range Province of the Intermontane Plateaus. The MLRA includes the Wasatch Mountains, which trend north and south, and the Uinta Mountains, which trend east and west. The steeply sloping, precipitous Wasatch Mountains have narrow crests and deep valleys. Active faulting and erosion are a dominant force in controlling the geomorphology of the area. The Uinta Mountains have a broad, gently arching, elongated shape. Structurally, they consist of a broadly folded anticline that has an erosion-resistant quartzite core. The Wasatch and Uinta Mountains have an elevation of 4,900 to about 13,500 feet (1,495 to 4,115 meters).

The mountains in this area are primarily fault blocks that have been tilted up. Alluvial fans at the base of the mountains are recharge zones for the basin fill aquifers. An ancient shoreline of historic Bonneville Lake is evident on the footslopes along the western edge of the area. Rocks exposed in the mountains are mostly Mesozoic and Paleozoic sediments, but Precambrian rocks are exposed in the Uinta Mountains. The Uinta Mountains are one of the few ranges in the United States that are oriented west to east. The southern Wasatch Mountains consist of Tertiary volcanic rocks occurring as extrusive lava and intrusive crystalline rocks.

The average precipitation is from 8 to 16 inches (203 to 406 mm) in the valleys and can range up to 73 inches (1854 mm) in the mountains. In the northern and western portions of the MLRA, peak precipitation occurs in the winter months. The southern and eastern portions have a greater incidence of high-intensity summer thunderstorms; hence, a significant amount of precipitation occurs during the summer months. The average annual temperature is 30 to 50 degrees Fahrenheit (-1 to 15 C). The freeze-free period averages 140 days and ranges from 60 to 220 days, generally decreasing in length with elevation.

The dominant soil orders in this MLRA are Aridisols, Entisols, Inceptisols, and Mollisols. The lower elevations are dominated by a frigid temperature regime, while the higher elevations experience cryic temperature regimes. Mesic temperature regimes come in on the lower elevations and south facing slopes in the southern portion of this MLRA. The soil moisture regime is typically xeric in the northern part of the MLRA, but grades to ustic in the extreme eastern and southern parts. The mineralogy is generally mixed and the soils are very shallow to very deep, generally well drained, and loamy or loamy-skeletal.

### LRU notes

E47C is the Uinta Mountains portion of MLRA 47 that run east and west which includes the Uinta Wilderness and The Flaming Gorge National Recreation Area and towns such as Evanston, Wyoming, Hanna and Tabiona, Utah. Structurally these mountains consist of a broadly folded anticline that has an erosion resistance quartzite core. The

Duchesne River and many other tributaries to the Green River run through this range, as well as the headwaters of the Bear River.

## Ecological site concept

This site occurs along the terraces along stream channels and in depression pockets on valley floors. It has a plant composition of basin big sagebrush; basin wildrye; Slender wheatgrass; western wheatgrass; sulfur-flowered buckwheat; rubber rabbitbrush.

The soils of this site formed mostly in slope alluvium from sedimentary rock. Surface soils are fine sandy loam to loam in texture. Rock fragments may be present on the soil surface and throughout the profile, but make up less than 35 percent of the soil volume. These soils are deep to very deep, well-drained, and have moderately slow to moderate permeability. pH is slightly to moderately alkaline. Available water-holding capacity ranges from 6.0 to 7.5 inches of water in the upper 60 inches of soil. The soil moisture regime is mostly ustic and the soil temperature regime is frigid. Precipitation ranges from 12 to 16 inches annually.

## Associated sites

R047XC003UT	<b>Interzonal Semi-wet Streambank (narrowleaf cottonwood)</b> These sites can occur adjacent to each other.
-------------	--

## Similar sites

R047XA016UT	<b>Loamy Bottom (basin wildrye)</b> These sites are very similar just in adjacent LRUs.
-------------	--

**Table 1. Dominant plant species**

Tree	Not specified
Shrub	(1) <i>Artemisia tridentata ssp. tridentata</i>
Herbaceous	Not specified

## Physiographic features

This ecological site typically occurs on alluvial fans and fan remnants. Slopes normally range from 2 to 10 percent. Sites are typically located between 6,400 to 9,500 feet in elevation.

**Table 2. Representative physiographic features**

Landforms	(1) Alluvial fan (2) Fan remnant
Flooding duration	Brief (2 to 7 days)
Flooding frequency	None to very rare
Ponding frequency	None
Elevation	6,400–9,500 ft
Slope	2–10%
Aspect	Aspect is not a significant factor

## Climatic features

The climate is characterized by cool, moist summers and cold, snowy winters. Approximately 60 percent of the moisture comes as rain from May through October. On the average, January through April are the driest months and May through October are the wettest months.

**Table 3. Representative climatic features**

Frost-free period (characteristic range)	90-110 days
Freeze-free period (characteristic range)	
Precipitation total (characteristic range)	12-16 in

## Influencing water features

This site receives extra water (run-in) from adjacent upland positions as it is located in a low position on the landscape. It does not have a water table within 60 inches.

## Wetland description

N/A

## Soil features

The soils of this site formed mostly in slope alluvium from sedimentary rock. Surface soils are fine sandy loam to loam in texture. Rock fragments may be present on the soil surface and throughout the profile, but make up less than 35 percent of the soil volume. These soils are deep to very deep, well-drained, and have moderately slow to moderate permeability. pH is slightly to moderately alkaline. Available water-holding capacity ranges from 6.0 to 7.5 inches of water in the upper 60 inches of soil. The soil moisture regime is mostly ustic and the soil temperature regime is frigid. Precipitation ranges from 12 to 16 inches annually.

**Table 4. Representative soil features**

Parent material	(1) Slope alluvium–sedimentary rock
Surface texture	(1) Loam (2) Fine sandy loam
Family particle size	(1) Fine-loamy
Drainage class	Well drained
Permeability class	Moderately slow to moderate
Depth to restrictive layer	60–100 in
Soil depth	60–100 in
Surface fragment cover <=3"	0–1%
Available water capacity (20-40in)	6–7.5 in
Calcium carbonate equivalent (20-40in)	2–13%
Electrical conductivity (20-40in)	0–1 mmhos/cm
Sodium adsorption ratio (20-40in)	0–3
Soil reaction (1:1 water) (20-40in)	7.6–8.4
Subsurface fragment volume <=3" (20-40in)	0–1%
Subsurface fragment volume >3" (20-40in)	0%

## Ecological dynamics

It is impossible to determine in any quantitative detail the Historic Climax Plant Community (HCPC) for this

ecological site because of the lack of direct historical documentation preceding all human influence. In some areas, the earliest reports of dominant plants include the cadastral survey conducted by the General Land Office, which began in the late 19th century for this area (Galatowitsch 1990). However, up to the 1870s the Shoshone Indians, prevalent in northern Utah and neighboring states, grazed horses and set fires to alter the vegetation for their needs (Parson 1996). In the 1860s, Europeans brought cattle and horses to the area, grazing large numbers of them on unfenced parcels year-long (Parson 1996). Itinerant and local sheep followed, largely replacing cattle as the browse component increased.

Below is a State and Transition Model diagram to illustrate the “phases” (common plant communities), and “states” (aggregations of those plant communities) that can occur on the site. Differences between phases and states depend primarily upon observations of a range of disturbance histories in areas where this ESD is represented. These situations include grazing gradients to water sources, fence-line contrasts, patches with differing dates of fire, herbicide treatment, tillage, etc. Reference State 1 illustrates the common plant communities that probably existed just prior to European settlement.

The major successional pathways within states, (“community pathways”) are indicated by arrows between phases. “Transitions” are indicated by arrows between states. The drivers of these changes are indicated in codes decipherable by referring to the legend at the bottom of the page and by reading the detailed narratives that follow the diagram. The transition between Reference State 1 and State 2 is considered irreversible because of the naturalization of exotic species of both flora and fauna, possible extinction of native species, and climate change. There may have also been accelerated soil erosion.

When available, monitoring data (of various types) were employed to validate more subjective inferences made in this diagram. See the complete files in the office of the State Range Conservationist for more details.

The plant communities shown in this State and Transition Model may not represent every possibility, but are probably the most prevalent and recurring plant communities. As more monitoring data are collected, some phases or states may be revised, removed, and/or new ones may be added. None of these plant communities should necessarily be thought of as “Desired Plant Communities.” According to the USDA NRCS National Range & Pasture Handbook (USDA-NRCS 2003), Desired Plant Communities (DPC’s) will be determined by the decision-makers and will meet minimum quality criteria established by the NRCS. The main purpose for including descriptions of a plant community is to capture the current knowledge at the time of this revision.

#### State 1: Reference State

The Reference State is a description of this ecological site just prior to Euro-American settlement but long after the arrival of Native Americans. The description of the Reference State was determined by NRCS Soil Survey Type Site Location information and familiarity with rangeland relict areas where they exist. The Reference State for this site would have been characterized as a shrub steppe co-dominated by basin big sagebrush (*Artemisia tridentata* ssp. *tridentata*), the dominant shrub, and having a rich herbaceous understory. The proportions of shrubs and herbs would have been dependent upon the length of time elapsed since the last wildfire or other sagebrush-killing event. If fire had not occurred within the past 30 years (1.2a), basin big sagebrush would have been the dominant shrub, having a native perennial herbaceous understory (1.1). If less than 10 years had elapsed since the last fire (1.1a), perennial native herbs would have increased and the shrub component would have been dominated by root-sprouting species such as rubber rabbitbrush (*Ericameria nauseosa*), and yellow rabbitbrush (*Chrysothamnus viscidiflorus*) (1.2). Soil anoxia from extremely wet years or an outbreak of Aroga (Aroga spp.) moth (1.1b) could have also reduced sagebrush and enhanced root-sprouting shrubs and perennial herbs (1.2) in some years. The same effect would have also been achieved by parch blight due to lack of snow cover during dry, cold winters (1.1c).

#### Community Phase 1.1: Basin big sagebrush/ abundant native perennial herbs

This plant community would have developed in the absence of recent fire and was characterized by basin big sagebrush and abundant native perennial herbs.

#### Community Pathway 1.1a

Wildfire would have removed basin big sagebrush, allowing root-sprouting shrubs and the native perennial forbs and grasses to increase.

#### Community Pathway 1.1b

An extremely wet period such as an El Niño-Southern Oscillation event and subsequent anoxic soil conditions would have killed off basin big sagebrush and converted the plant community to one dominated by root-sprouting shrubs and native perennial herbs. The same result would have been seen following a sudden insect (e.g. Aroga moth), or other pathogen outbreak on sagebrush.

#### Community Pathway 1.1c

Unusually cold, dry winters may have caused severe parch blight, killing off substantial portions of sagebrush and allowing roots-sprouting shrubs and native perennial herbs to dominate the plant community.

#### Community Phase 1.2: root-sprouting shrubs/ increased perennial herbs

This phase of the Reference State would have been dominated by root-sprouting shrubs such as rubber rabbitbrush, yellow rabbitbrush, and snakeweed (*Gutierrezia sarothrae*), with a rich understory of native perennial herbs.

#### Community Pathway 1.2a

In the absence of fire, this plant community would have responded with an increase in basin big sagebrush and a corresponding decrease in native perennial herbs.

#### T1a: Transition from State 1 to State 2 (Reference State to Basin Big Sagebrush/ Introduced Non-natives State)

The simultaneous introduction of exotic species, both plants and animals, and possible extinctions, along with climate change, has caused State 1 to transition to State 2. Reversal of such historic changes (i.e. a return pathway) back to State 1 is not practical.

#### State 2: Basin Big Sagebrush/ Introduced Non-native Herbs State

State 2 is very similar to State 1 in form and function, with the exception of the presence of non-native plants and animals, possible extinctions of native species, and a different climate. State 2 is a description of the ecological site shortly following Euro-American settlement. This State can be regarded as the current potential. As with State 1, a shift will be seen in the abundance of basin big sagebrush relative to the perennial herbs based upon the amount of time that has elapsed since the last wildfire or other sagebrush-killing event. Wildfire (2.1a) will temporarily remove basin big sagebrush, allowing root-sprouting shrubs and all types of herbs (both native and non-native) to increase (2.2). Lack of fire (2.2a) will favor the return of basin big sagebrush provided that there is adequate seed source from adjacent unburned areas. Perennial native herbs and non-native annuals will maintain their presence post-fire. Other drivers that could reduce sagebrush and favor root-sprouting shrubs (2.2) include anoxic soils from extremely wet years, outbreaks of Aroga moth (2.1b), or parch blight due to lack of snow cover during dry cold winters (2.1c). The resiliency of this State is maintained by a healthy, productive, and diverse plant community that can provide native seed sources and promotes soil stability, water infiltration, and soil moisture retention. The resiliency of this State can be maintained by reducing livestock grazing impacts, especially during the growing season of perennial herbs. Conversely, continued heavy grazing will negatively impact the resiliency of this State.

#### Community Phase 2.1: Basin big sagebrush/ abundant native perennial herbs

This plant community will develop in the absence of fire and is characterized by basin big sagebrush with an understory made up of both native perennial and introduced herbs. Common invaders are cheatgrass and Russian thistle.

#### Community Pathway 2.1a

Wildfire will remove basin big sagebrush, allowing root-sprouting shrubs and the native perennial forbs and grasses to increase.

#### Community Pathway 2.1b

An extremely wet period such as an El Niño-Southern Oscillation event and subsequent anoxic soil conditions can kill basin big sagebrush and convert the plant community to one dominated by root-sprouting shrubs and native perennial herbs. The same result would be seen following a sudden insect (e.g. Aroga moth) or other pathogen outbreak on sagebrush.

#### Community Pathway 2.1c

Unusually cold, dry winters may cause severe parch blight, killing substantial portions of sagebrush and allowing roots-sprouting shrubs and native perennial herbs to dominate the plant community.

Community Phase 2.2: root-sprouting shrubs/ increased native perennial herbs

This plant community is dominated by root-sprouting shrubs such as rubber rabbitbrush, and yellow rabbitbrush, with a rich understory of native perennial herbs.

Community Pathway 2.2a

In the absence of fire, this plant community will respond with an increase in basin big sagebrush and a corresponding decrease in native perennial herbs.

T2a: Transition from State 2 to State 3 (Basin Big Sagebrush/ Introduced Non-native Herbs State to Brush Super-dominance State)

The Basin Big Sagebrush/ Introduced Non-natives State will transition to the Brush Super-dominance State following excessive livestock grazing, particularly during the growing season of herbs. Native perennial herbs are eventually depleted such that mere reduction or removal of livestock will not allow for their recovery. The approach to this transition is indicated by the dominance of large, old sagebrush. This transition can be avoided by removal or reduction of sagebrush by prescribed fire, herbicides, or mechanical means well before the diminishment of native perennial herbs has occurred.

State 3: Brush Super-dominance State

With multiple-year heavy livestock grazing, especially during the growing season, native perennial herbs are diminished. Once the soil seed reserve is exhausted, there is little opportunity for recovery. In the absence of fire (3.2a) basin big sagebrush will begin to dominate (3.1). Where mechanical or fire damage occur to the non-sprouting basin big sagebrush (3.1a), root-sprouting shrubs can increase (3.2). The state is maintained by the lack of a healthy, productive and diverse herb component capable of providing native seed source, soil stabilization, and soil moisture retention.

Community Phase 3.1: Basin big sagebrush super-dominance

This plant community is characterized as a basin big sagebrush-dominated site where the understory is greatly diminished in species richness and abundance from heavy continuous livestock grazing and lack of fire.

Community Pathway 3.1a

Wildfire or mechanical removal of sagebrush will develop a plant community dominated by root-sprouting shrubs.

Community Phase 3.2: Root-sprouting shrubs super-dominance

As the site deteriorates from heavy continuous livestock grazing compounded by fire or mechanical removal of sagebrush, the plant community will become dominated by root-sprouting shrubs such as rubber rabbitbrush, and yellow rabbitbrush.

Community Pathway 3.2a

After an extended period without wildfire, provided a viable seed source is available, basin big sagebrush will begin to re-establish and dominate the site.

T3a: Transition from State 3 to State 4 (Brush Super-dominance State to Seeded State)

Because reduction or exclusion of livestock use will not allow ready recovery of the herbaceous understory in State 3, the manager is left with few options to increase the perennial herbaceous cover. Tillage followed by re-seeding is the usual action required. Thus, the transition from a Brush Super-dominance State (regardless of phase) to the Seeded State is commonly seen.

State 4: Seeded State

The most common seedings of the past have been to Eurasian wheatgrasses (*Agropyron* spp.) or ryegrasses (*Elymus* spp.) (4.1). Where tillage has been employed, the native forbs and browse have most likely been destroyed. Thus, if a more diverse plant community is required (4.2), other species will have to be added to the seed mix and utilization by livestock deferred for several years (4.1a). In some circumstances, the native forbs and shrubs will slowly re-establish (4.2 and 4.3) when adjacent area have not been tilled. Subsequent re-treatment with herbicide or mechanical (e.g. Lawson pasture-aerator) action (4.2a and 4.3a) will be necessary to maintain grass dominance (4.1). Fortunately, annual invaders such as cheatgrass are short-lived where Wasatch Formation-derived soils (MLRA 47A) or the Gilbert Land Surface (MLRA 47C) are involved, both being of nutrient-poor parent materials. Once a site is re-established with forbs and shrubs (4.2) and a sufficient length of time has elapsed since the last fire (4.2b), pioneering shrubs such as snakeweed, rubber rabbitbrush, and yellow rabbitbrush may dominate

the site (4.3). Returning to a more diverse plant community (4.2) may require mechanically removing some shrubs and re-seeding (4.3b). This State can be maintained by moderate levels of livestock use or alteration of dates of use, particularly during the boot stage of the grass. Heavy spring use by livestock will reduce the resiliency of this State.

#### Community Phase 4.1: crested wheatgrass monoculture

This plant community is predominantly a monoculture of a seeded species, commonly crested wheatgrass (*Agropyron cristatum*).

#### Community Pathway 4.1a

Re-seeding with a mix of forbs and shrubs combined with limited use/prescribed grazing by livestock will be necessary to facilitate the re-establishment of a more diverse plant community.

#### Community Phase 4.2: re-invaded herbs and shrubs

This plant community is characterized by a mix of native and non-native herbs and shrubs that have re-invaded or been seeded into the site. Disturbance follower species that may be present include snakeweed, rubber rabbitbrush, yellow rabbitbrush, and Russian thistle (*Salsola* sp.). Other re-invaders could also include bulbous bluegrass (*Poa bulbosa*), Sandberg bluegrass (*Poa secunda*), or Kentucky bluegrass (*Poa pratensis*).

#### Community Pathway 4.2a

Either mechanical or chemical brush management will be required to maintain a grass-dominated site.

#### Community Pathway 4.2b

The absence of fire will shift this community into a re-invaded shrub-dominated site.

#### Community Phase 4.3: re-invaded shrub dominance

Disturbance following shrubs such as snakeweed, rubber rabbitbrush, and yellow rabbitbrush may dominate the site in the absence of fire.

#### Community Pathway 4.3a

Either mechanical or chemical brush management will be required to maintain a grass-dominated site.

#### Community Pathway 4.3b

Mechanically removing some shrubs and re-seeding with a diverse mixture of forbs and grasses will improve the balance between the herbaceous and shrub components.

## State and transition model

#### 4. Seeded State

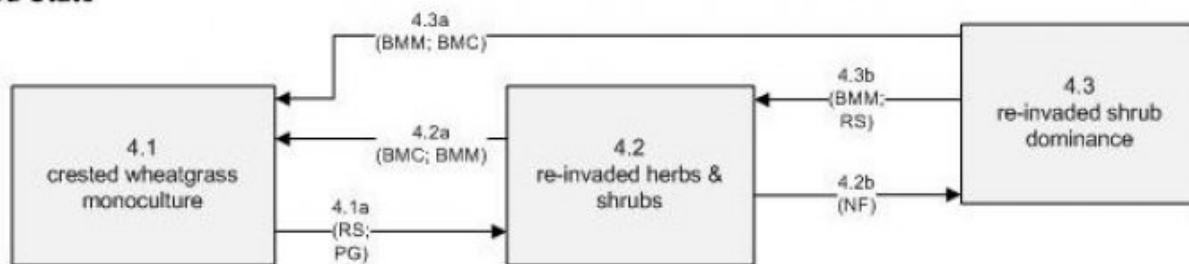

#### 3. Brush Super-dominance State

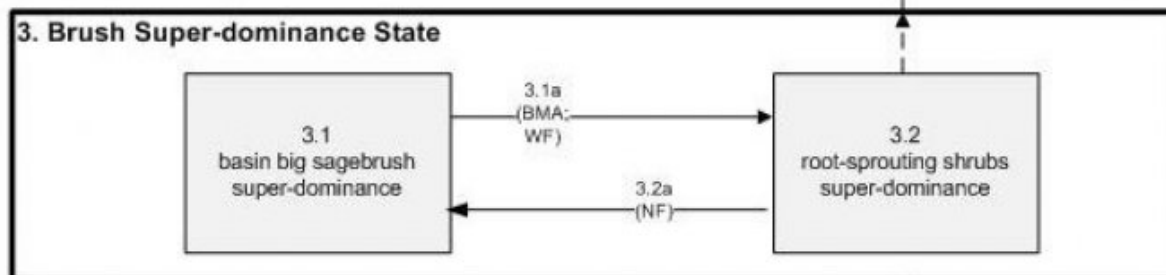

#### 2. Basin Big Sagebrush/ Introduced Non-native Herbs State

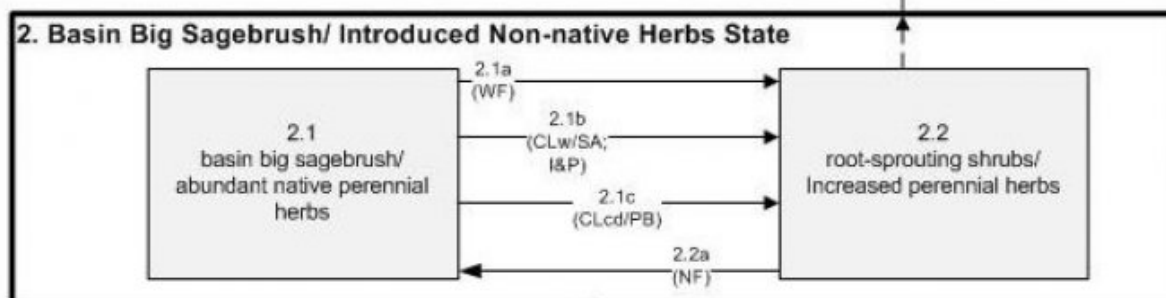

#### 1. Reference State

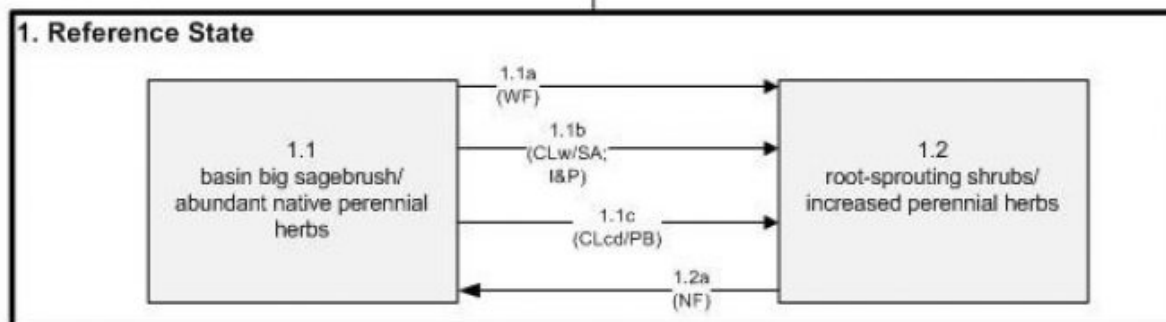

BMA	Brush Management All (Chemical, Fire, Mechanical)	NF	No Fire
BMC	Brush Management (Chemical)	PB	Parch Blight
BMM	Brush Management (Mechanical)	PG	Prescribed Grazing
CLcd	Climate (unusually cold and dry)	RS	Re-seed
CLw	Climate (unusually wet)	SA	Soil Anoxia
HC	Historic Change	Till	Tillage
HCSLG	Heavy Continuous Season Long Grazing	WF	Wildfire
I&P	Insects & (Other) Pathogens		

#### Inventory data references

Information presented here has been derived from NRCS clipping data and other inventory data. Field observations



from range trained personnel were also used.

## Other references

Alexander, R. R. 1985. Major habitat types, community types, and plant communities in the Rocky Mountains. USDA- Forest Service Rocky Mountain Forest and Range Experiment Station. General technical report RM-123. 105p.

Alexander 1988. Forest vegetation on National Forests in the Rocky Mountain and Intermountain Regions: Habitat types and community types. USDA- Forest Service Rocky Mountain Forest and Range Experiment Station. General technical report RM-162. 47p.

Galatowitsch, S.M. 1990. Using the original land survey notes to reconstruct pre-settlement landscapes in the American West. Great Basin Naturalist: 50(2): 181-191. Keywords: [Western U.S., conservation, history, human impact]

Parson, R. E. 1996. A History of Rich County. Utah State Historical Society, County Commission, Rich County, Utah. Keywords: [Rich County, Utah, Historic land use, European settlements]

USDA-NRCS. 2003. National Range and Pasture Handbook. in USDA, editor, USDA-Natural Resources Conservation Service-Grazing Lands Technology Institute. Keywords: [Western US, Federal guidelines, Range pasture management]

Western Regional Climate Center, Western U.S. Climate Historical Summaries. Available at: <http://www.wrcc.dri.edu/summary/Climsmut.html>. Accessed 15 June 2009.

Web Soil Survey, Official Soil Series Descriptions. Available at: <http://soils.usda.gov/technical/classification/osd/index.html>. Accessed 15 June 2009.

## Contributors

M. Dean Stacy

## Approval

Sarah Quistberg, 2/11/2025

## Rangeland health reference sheet

Interpreting Indicators of Rangeland Health is a qualitative assessment protocol used to determine ecosystem condition based on benchmark characteristics described in the Reference Sheet. A suite of 17 (or more) indicators are typically considered in an assessment. The ecological site(s) representative of an assessment location must be known prior to applying the protocol and must be verified based on soils and climate. Current plant community cannot be used to identify the ecological site.

Author(s)/participant(s)	
Contact for lead author	
Date	02/26/2025
Approved by	Sarah Quistberg
Approval date	
Composition (Indicators 10 and 12) based on	Annual Production

## Indicators

1. **Number and extent of rills:**

---

2. **Presence of water flow patterns:**

---

3. **Number and height of erosional pedestals or terracettes:**

---

4. **Bare ground from Ecological Site Description or other studies (rock, litter, lichen, moss, plant canopy are not bare ground):**

---

5. **Number of gullies and erosion associated with gullies:**

---

6. **Extent of wind scoured, blowouts and/or depositional areas:**

---

7. **Amount of litter movement (describe size and distance expected to travel):**

---

8. **Soil surface (top few mm) resistance to erosion (stability values are averages - most sites will show a range of values):**

---

9. **Soil surface structure and SOM content (include type of structure and A-horizon color and thickness):**

---

10. **Effect of community phase composition (relative proportion of different functional groups) and spatial distribution on infiltration and runoff:**

---

11. **Presence and thickness of compaction layer (usually none; describe soil profile features which may be mistaken for compaction on this site):**

---

12. **Functional/Structural Groups (list in order of descending dominance by above-ground annual-production or live foliar cover using symbols: >>, >, = to indicate much greater than, greater than, and equal to):**

Dominant:

Sub-dominant:

Other:

Additional:

---

13. **Amount of plant mortality and decadence (include which functional groups are expected to show mortality or decadence):**

---

14. **Average percent litter cover (%) and depth ( in):**

---

15. **Expected annual annual-production (this is TOTAL above-ground annual-production, not just forage annual-production):**

---

16. **Potential invasive (including noxious) species (native and non-native). List species which BOTH characterize degraded states and have the potential to become a dominant or co-dominant species on the ecological site if their future establishment and growth is not actively controlled by management interventions. Species that become dominant for only one to several years (e.g., short-term response to drought or wildfire) are not invasive plants. Note that unlike other indicators, we are describing what is NOT expected in the reference state for the ecological site:**

---

17. **Perennial plant reproductive capability:**

---