

Ecological site R048AY008UT Wet Fresh Meadow (Willow-Sedge)

Last updated: 3/01/2024
Accessed: 05/07/2024

General information

Provisional. A provisional ecological site description has undergone quality control and quality assurance review. It contains a working state and transition model and enough information to identify the ecological site.

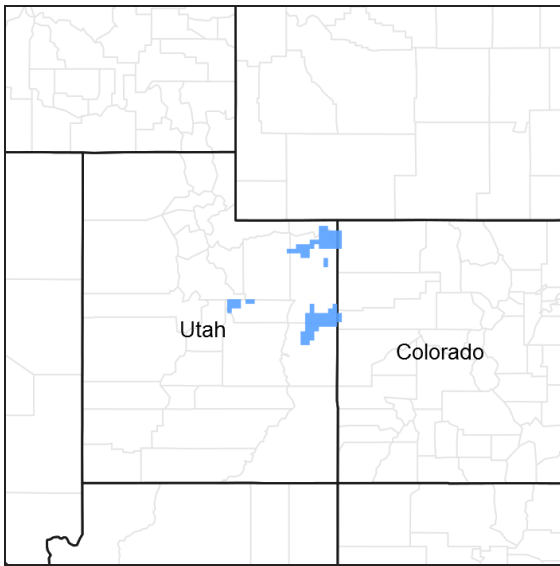

Figure 1. Mapped extent

Areas shown in blue indicate the maximum mapped extent of this ecological site. Other ecological sites likely occur within the highlighted areas. It is also possible for this ecological site to occur outside of highlighted areas if detailed soil survey has not been completed or recently updated.

MLRA notes

Major Land Resource Area (MLRA): 048A–Southern Rocky Mountains

MLRA 48A makes up about 45,920 square miles (119,000 square kilometers) and is the southern part of the Rocky Mountains. The Southern Rocky Mountains lies east of the Colorado Plateau, south of the Wyoming Basin, west of the Great Plains, and north of the Rio Grande Rift. It is in western and central Colorado, southeastern Wyoming, eastern Utah, and northern New Mexico. The headwaters of major rivers such as the Colorado, Yampa, Arkansas, Rio Grande, North Platte and South Plate rivers are located here. This MLRA has numerous national forests, including the Medicine Bow National Forest in Wyoming; the Routt, Arapaho, Roosevelt, Pike, San Isabel, White River, Gunnison, Grand Mesa, Uncompahgre, Rio Grande, and San Juan National Forests in Colorado; the Carson National Forest and part of the Santa Fe National Forest in New Mexico. Rocky Mountain National Park also is in this MLRA.

MLRA 48A is the southern Rocky Mountains physiographic region. The Southern Rocky Mountains consist primarily of two belts of strongly sloping to precipitous mountain ranges trending north to south. Several basins, or parks, are between the belts. Some high mesas and plateaus are included. It is characterized by mountain ranges that were uplifted during the Laramide Orogeny and then had periods of glaciation. The ranges include the Sangre de Cristo Mountains, the Laramie Mountains, and the Front Range in the east and the San Juan Mountains and the Sawatch and Park Ranges in the west. The ranges are dissected by many narrow stream valleys having steep gradients. In some areas the upper mountain slopes and broad crests are covered by snowfields and glaciers. Elevation typically

ranges from 6,500 to 14,400 feet (1,980 to 4,390 meters) in this area. The part of this MLRA in central Colorado includes the highest point in the Rockies, Mount Elbert, which reaches an elevation of 14,433 feet (4,400 meters). More than 50 peaks in the part of the MLRA in Colorado are at an elevation of more than 14,000 feet (4,270 meters). Many small glacial lakes are in the high mountains.

The mountains in this area were formed mainly by crustal uplifts during the late Cretaceous and early Tertiary periods. This large MLRA can be subdivided into at least 4 large general divisions. First is the Rockies on the east side of this area are called the "Front Range," which is a fault block that has been tilted up on edge and uplifted and is largely igneous and metamorphic geology. It was tilted up on the east edge, so there is a steep front on the east and the west side is more gently sloping and in the south east there are rocks exposed in the mountains are mostly Precambrian igneous and metamorphic rocks. Second is the tertiary rocks, primarily basalt and andesitic lava flows, tuffs, breccias, and conglomerates, are throughout this area (San Juan Mountains Area). The third division is Northwest part of the MLRA is dominantly sedimentary rock from the cretaceous/tertiary and Permian/Pennsylvanian periods. The fourth subset is the long and narrow Sangre de Cristos mountains uplifted in the Cenozoic are between the Rio Grande rift and the great plains. Many of the highest mountain ranges were reshaped by glaciation during the Pleistocene. Alluvial fans at the base of the mountains are recharge zones for local basin and valley fill aquifers. They also are important sources of sand and gravel.

The average annual precipitation ranges predominantly from 12 to 63 inches. Summer rainfall commonly occurs as high-intensity, convective thunderstorms. About half of the annual precipitation occurs as snow in winter; this proportion increases with elevation. In the mountains, deep snowpacks accumulate throughout the winter and generally persist into spring or early summer, depending on elevation. Some permanent snowfields and small glaciers are on the highest mountain peaks. In the valleys at the lower elevations, snowfall is lighter and snowpacks can be intermittent. The average annual temperature is 26 to 54 degrees F (-3 to 12 degrees C). The freeze-free period averages 135 days and ranges from 45 to 230 days, decreasing in length with elevation. The climate of this area is strongly dependent upon elevation; precipitation is greater, and temperatures are cooler at the higher elevations. The plant communities vary with elevation, aspect and change in latitudes due to changing in precipitation kind and timing and temperature.

The dominant soil orders in this MLRA are Mollisols, Alfisols, Inceptisols, and Entisols. The soils in the area dominantly have a frigid or cryic soil temperature regime and an ustic or udic soil moisture regime. Mineralogy is typically mixed, smectitic, or paramicaceous. In areas with granite, gneiss, and schist bedrock, Glossocryalfs (Seitz, Granile, and Leadville series) and Haplocryolls (Rogert series) formed in colluvium on mountain slopes. Dystrocryepts (Leighcan and Mummy series) formed on mountain slopes and summits at the higher elevations. In areas of andesite and rhyolite bedrock, Dystrocryepts (Endlich and Whitecross series) formed in colluvium on mountain slopes. In areas of sedimentary bedrock, Haplustolls (Towave series) formed on mountain slopes at low elevations and with low precipitation. Haplocryolls (Lamphier and Razorba series), Argicryolls (Cochetopa series), and Haplocryalfs (Needleton series) formed in colluvium on mountain slopes at high elevations.

Ecological site concept

The soil is deep and affected by wetness. The water table fluctuates during the growing season, generally above 20 inches. Drainage characteristics range from imperfectly to poorly, with the imperfectly drained soils having a higher water table than is common for the site. Surface soils are generally dark colored and high in organic matter content. Textures of these soils range from moderately coarse to fine and are most commonly medium and moderately alkaline and from non-calcareous to strongly calcareous. These soils are forming in lowland areas on nearly level to gently sloping or undulating topography. Parent materials are derived from a wide range of parent rock and lacustrine sediments. Roots and water move readily through these soils above the water table. Water holding capacity is moderate to high and is supplemented by upward capillary movement from the shallow water table. Erosion is not a serious hazard on these soils.

Associated sites

R048AY006UT	Semiwet Fresh Streambank
-------------	--------------------------

Table 1. Dominant plant species

Tree	Not specified
------	---------------

Shrub	Not specified
Herbaceous	(1) <i>Carex nebrascensis</i> (2) <i>Carex aquatilis</i>

Physiographic features

Drainageways and flood plains.

Table 2. Representative physiographic features

Landforms	(1) Drainageway (2) Flood plain
Runoff class	Low
Flooding duration	Very brief (4 to 48 hours) to brief (2 to 7 days)
Flooding frequency	None to occasional
Ponding frequency	None
Elevation	1,768–2,743 m
Slope	0–15%
Ponding depth	Not specified
Water table depth	25–102 cm

Climatic features

Average annual precipitation is 14 to 16 inches. Approximately 55 percent occurs as rain from May through October. On the average, November through June are the driest months and July through October are the wettest months. Cool temperatures and length of growing season are important environmental factors in this site. In average years, plants begin growth around April 20 and end growth around September 30.

Table 3. Representative climatic features

Frost-free period (characteristic range)	
Freeze-free period (characteristic range)	90-110 days
Precipitation total (characteristic range)	356-406 mm

Influencing water features

This site has a water table from 10-40 inches in depth.

Soil features

The soil is deep and affected by wetness. The water table fluctuates during the growing season, generally above 20 inches. Drainage characteristics range from imperfectly to poorly, with the imperfectly drained soils having a higher water table than is common for the site. Surface soils are generally dark colored and high in organic matter content. Textures of these soils range from moderately coarse to fine and are most commonly medium and moderately alkaline and from non-calcareous to strongly calcareous. These soils are forming in lowland areas on nearly level to gently sloping or undulating topography. Parent materials are derived from a wide range of parent rock and lacustrine sediments. Roots and water move readily through these soils above the water table. Water holding capacity is moderate to high and is supplemented by upward capillary movement from the shallow water table. Erosion is not a serious hazard on these soils.

Modal Soil: Iceslew SiL, 1 to 3 % — fine-loamy, mixed, (calc.), frigid Aeric Fluvaquents

Table 4. Representative soil features

Parent material	(1) Alluvium–sandstone and shale
Surface texture	(1) Silt loam (2) Loam
Family particle size	(1) Fine-loamy
Drainage class	Poorly drained to moderately well drained
Permeability class	Moderately slow to moderate
Depth to restrictive layer	152–203 cm
Soil depth	152–203 cm
Surface fragment cover <=3"	0–5%
Surface fragment cover >3"	0%
Available water capacity (Depth not specified)	10.16–22.86 cm
Calcium carbonate equivalent (Depth not specified)	0–15%
Electrical conductivity (Depth not specified)	0–4 mmhos/cm
Sodium adsorption ratio (Depth not specified)	0–5
Soil reaction (1:1 water) (Depth not specified)	7.4–8.4
Subsurface fragment volume <=3" (Depth not specified)	0–15%
Subsurface fragment volume >3" (Depth not specified)	0–10%

Ecological dynamics

Reference State

Community Phase 1.1: willow shrub carr/ rich & productive understory

Without disturbance, the Reference State would have been dominated by woody plants. The proportion of woody plants in relation to herbaceous understory species would have been influenced by the time and type of natural disturbance that most recently took place. Possible natural disturbances would have included beaver and/or moose consumption of willow, deciduous wood pathogens (i.e. insects) reducing particular species, wildfires, and extreme run-off causing flooding or diversion of existing drainages. Such disturbances would have temporarily decreased the woody component and allowed an increase in herbs. All of these influences tended to have very long return intervals. Without such disturbance, woody plants would have increased at the expense of the understory because of the overtopping shade they create.

T1a: Transition from State 1 to State 2 (Reference State to Willow Shrub Carr/ Diminished Understory State)

The simultaneous introduction of exotic species, both plants and animals, and possible extinctions of native flora and fauna, along with climate change, has caused State 1 to transition to State 2. Reversal of such historic changes (i.e. a return pathway) back to State 1 is not practical.

Willow Shrub Carr/ Diminished Understory State

State 2 is very similar to State 1 in form and function, with the exception of the presence of non-native plants and animals, possible extinctions of native species, and a different climate.

State 2 is a description of the ecological site shortly following Euro-American settlement. This state can be regarded as the current potential. State 2 can fluctuate between two willow-dominated phases: one that is relatively undisturbed with a rich and productive understory (2.2), and another where the understory is reduced due to the heavy livestock grazing (2.1). Phase 2.1 is a willow (*Salix* spp.) stand with a reduced understory due to the heavy

livestock grazing. This Phase was also produced by horses and mules belonging to early European settlers and travelers (2.2a). These areas usually have surface water available, an attractant to most animals in the vicinity, which tend to pass through these stands at least once daily to feed, get water, and find shade. Heavy use of this part of the landscape was common. Because of the high resilience of these sub-irrigated habitats, partial recovery of the understory was attained in many instances and accelerated soil erosion arrested. Sustainable use was approached in such instances (2.1a).

Community Phase 2.1: increased willows & unpalatable forbs/ diminished understory

Periods of heavy livestock and/or trailstock grazing of the herbaceous understory, along with near-extirpation of beaver and moose, causes this plant community to experience an increase in the proportion of woody plants at the expense of the herbaceous understory. Sedges, unpalatable forbs, and woody species are increased.

Community Pathway 2.1a:

A reduction in livestock numbers and limiting seasons of use allows the understory component to rejuvenate.

Community Phase 2.2: willow shrub carr/ rich & productive understory

This plant community has regained the understory components following a period of reduction in livestock use.

Community Pathway 2.2a:

Heavy continuous season long grazing by livestock reduces the palatable understory species. This occurred in the past when these sites were common places for travelers to feed and water their animals.

T2a: Transition from State 2 to State 3 (Willow Shrub Carr/ Diminished Understory State to Xerified Shrubland State)

Excessive season-long livestock (or trailstock use in the past) involves high intensities of forage utilization, trampling, and bedding. Salting was common on such locations. When ground cover is reduced, accelerated soil erosion is possible. These impacts, along with logging in the watersheds above, results in accelerated channel down-cutting, more extreme flooding, and changes in drainage patterns. The overall result is a xerification of the site and lignification of its vegetation (an increase in woody vegetation). The approach to this transition is indicated by changes in species composition – primarily an increase in woody vegetation. The trigger causing this transition is stream down-cutting due to extreme hydrologic events.

Xerified Shrubland State

Where control of grazing intensity isn't been achieved earlier and excessive use by livestock prevails, the vegetation takes on more of the character of that of drier sites at low elevations. As the water table is lowered, the stature of the willows and other riparian shrubs declines, allowing upland species such as rubber rabbitbrush (*Ericameria nauseosus*), Wyoming big sagebrush (*Artemisia tridentata* ssp. *wyomingensis*) to fill in these sites (3.2). Wildfire followed by continued heavy livestock grazing (3.2a) will temporarily remove the shrub and palatable herbaceous component, leaving annuals and biennials such as lesser burdock (*Arctium minus*), rough cocklebur (*Xanthium strumarium*), horehound (*Marrubium vulgare*), houndstongue (*Cynoglossum officinale*), stickseed (*Hackelia* spp.), Canada thistle (*Cirsium arvense*), and Scotch cottonthistle (*Onopordum acanthium*) to flourish (3.1). The recovery of moose and beaver puts more pressure on the remaining willows. However, if enough willow and other deciduous shrubs survive previous herbivory to allow beaver dam building, and thus re-ponding of these sites (R3a), it may be possible for the original mesic species to re-establish and for the site to return to State 2. A return to heavy livestock grazing and logging will negatively impact the resiliency of this State.

Community Phase 3.1: unpalatable annuals & biennials dominance

This plant community is dominated by assorted unpalatable annuals and biennials that gained dominance following wildfire and heavy continuous season long grazing. Some of the species may include burdock, cocklebur, horehound, houndstongue, stickseed, Canada thistle, and Scotch cottonthistle.

Community Pathway 3.1a:

Previous channelization and consequent lowering of the water table will over time lead to xerification of this site. This occurs because channelization moves water through the site rather than allowing it to infiltrate the soil and be retained for season-long plant growth.

Community Phase 3.2: Wyoming big sagebrush/ rubber rabbitbrush

This plant community is dominated by Wyoming big sagebrush and rubber rabbitbrush due to a lowering of the

water table and subsequent xerification of the site.

Community Pathway 3.2a:

In the event of wildfire followed by heavy grazing pressure by livestock the site will convert to one dominated by assorted unpalatable annual and biennial forbs.

T3a: Transition from State 3 to State 4 (Xerified Shrubland State to Seeded Grassland State)

If managers are dissatisfied with the levels of productivity and/or the dominance of undesirable and noxious weeds present in State 3, the location is suitable, and finances are available, they could till and re-seed with a suite of montane grasses that would not only increase forage but may help to stabilize streambanks as well.

R3a: Restoration Pathway from State 3 to State 2 (Xerified Shrubland State to Willow Shrub Carr/ Diminished Understory State)

It may be possible for this site to recover to a willow-dominated system where beaver populations and activity have been restored. The ponding caused by construction of beaver dams helps raise the water table, creating a less favorable environment for the upland species that moved in and allows the original mesic species to re-occupy the site.

Seeded Grassland State

A seeded grassland state is possible if the site is tilled and re-seeded to increase forage for livestock and to stabilize walls of streambanks. Levels of grazing will have to be controlled (4.2a) or the initially pure grassland (4.1) will quickly be re-invaded by rabbitbrush, sagebrush, willow, or other mesic shrubs (4.2), along with the noxious understory forbs such as burdock, cocklebur, horehound, houndstongue, stickseed, and a variety of thistles. Heavy continuous season long grazing would deplete the seeded grasses, giving an advantage to shrubs and other invasive species (4.1a).

Community Phase 4.1 pure grassland

This plant community is dominated by a suite of seeded grass species used to increase forage production for livestock and stabilize streambanks.

Community Pathway 4.1a:

Heavy continuous season long grazing will deplete the seeded grasses, allowing shrubs and other invasive species to re-establish.

Community Phase 4.2 shrub & weed invaded grassland

This plant community is a product of heavy grazing on seeded grass species. Seeded grasses are diminished and an encroachment of woody species including willow, sagebrush, or rabbitbrush has occurred.

Community Pathway 4.2a:

Moderation of grazing is required to sustain a purely grassland phase.

State and transition model

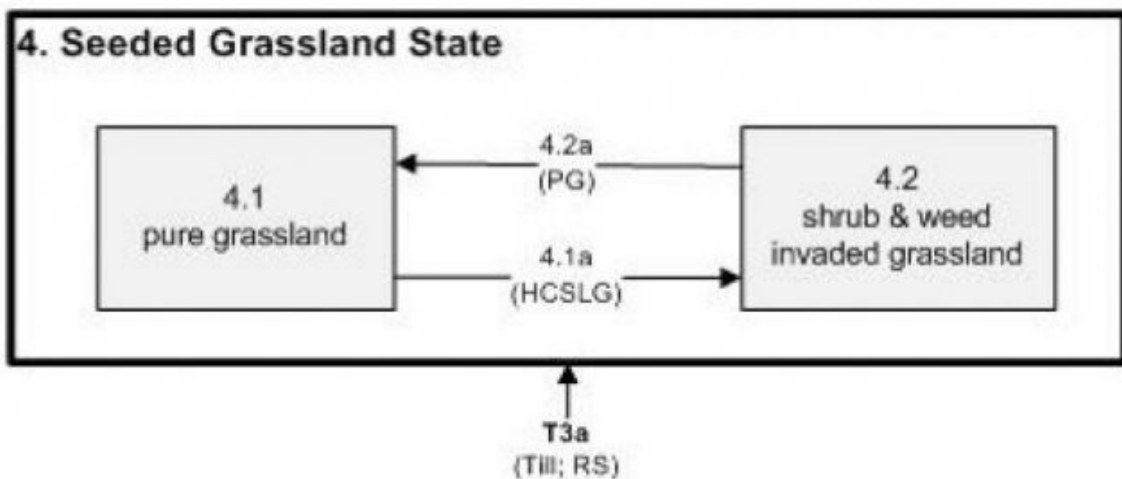

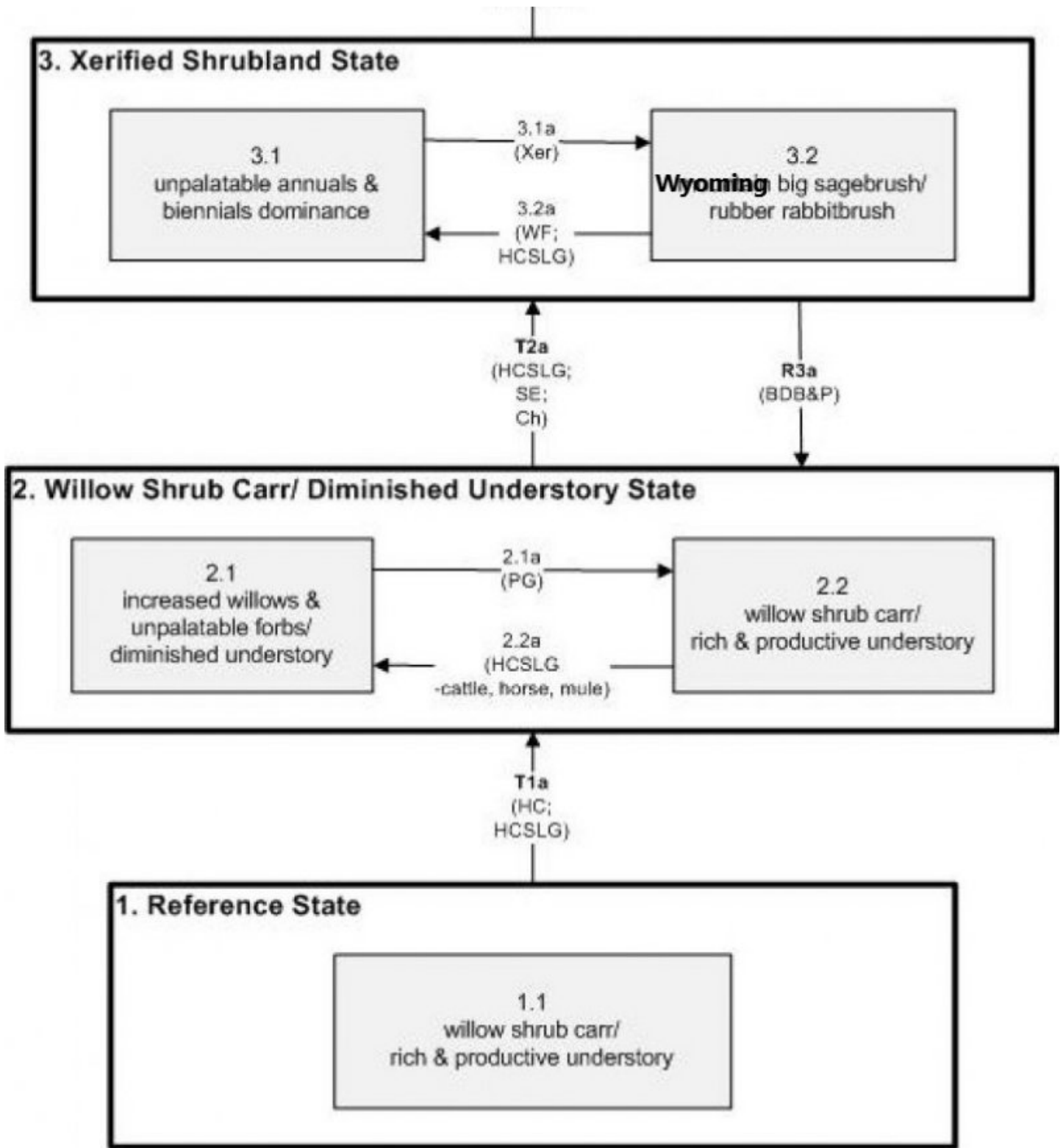

BDB&P	Beaver Dam Building & Ponding
Ch	Channelization (down-cutting)
HC	Historic Change
HCSLG	Heavy Continuous Season Long Grazing
PG	Prescribed Grazing
RS	Re-seeding
SE	Soil Erosion
Till	Tillage
WF	Wildfire
Xer	Xerification

Reference State

Community 1.1

Reference Plant Community

The general view of this site is sedges and willows. The natural plant community is composed of approximately 75 percent perennial grasses and grasslike plants, 10 percent forbs, and 15 percent shrubs.

Table 5. Annual production by plant type

Plant Type	Low (Kg/Hectare)	Representative Value (Kg/Hectare)	High (Kg/Hectare)
Grass/Grasslike	2059	2479	2900
Shrub/Vine	412	497	581
Forb	275	331	387
Total	2746	3307	3868

Table 6. Ground cover

Tree foliar cover	0%
Shrub/vine/liana foliar cover	4-6%
Grass/grasslike foliar cover	89-91%
Forb foliar cover	4-6%
Non-vascular plants	0%
Biological crusts	0%
Litter	0%
Surface fragments >0.25" and <=3"	0%
Surface fragments >3"	0%
Bedrock	0%
Water	0%
Bare ground	0%

Table 7. Canopy structure (% cover)

Height Above Ground (M)	Tree	Shrub/Vine	Grass/ Grasslike	Forb
<0.15	–	–	–	–
>0.15 <= 0.3	–	–	–	4-6%
>0.3 <= 0.6	–	–	89-91%	–
>0.6 <= 1.4	–	–	–	–
>1.4 <= 4	–	4-6%	–	–
>4 <= 12	–	–	–	–
>12 <= 24	–	–	–	–
>24 <= 37	–	–	–	–
>37	–	–	–	–

Additional community tables

Table 8. Community 1.1 plant community composition

Group	Common Name	Symbol	Scientific Name	Annual Production (Kg/Hectare)	Foliar Cover (%)
-------	-------------	--------	-----------------	-----------------------------------	---------------------

Shrub/Vine					
0	Dominant Shrubs			168–370	
	Booth's willow	SABO2	<i>Salix boothii</i>	101–168	–
	Drummond's willow	SADR	<i>Salix drummondiana</i>	34–101	–
	narrowleaf willow	SAEX	<i>Salix exigua</i>	34–101	–
3	Sub-Dominant Shrubs			202–471	
	Shrub (>.5m)	2SHRUB	<i>Shrub (>.5m)</i>	101–168	–
	shrubby cinquefoil	DAFRF	<i>Dasiphora fruticosa</i> ssp. <i>floribunda</i>	34–101	–
	whitestem gooseberry	RIIN2	<i>Ribes inerme</i>	34–101	–
	Woods' rose	ROWO	<i>Rosa woodsii</i>	34–101	–
Grass/Grasslike					
0	Dominant Grasses & Grass-likes			942–1849	
	water sedge	CAAQ	<i>Carex aquatilis</i>	168–336	–
	smallwing sedge	CAMI7	<i>Carex microptera</i>	168–336	–
	Nebraska sedge	CANE2	<i>Carex nebrascensis</i>	168–336	–
	tufted hairgrass	DECE	<i>Deschampsia cespitosa</i>	168–336	–
	mountain rush	JUARL	<i>Juncus arcticus</i> ssp. <i>littoralis</i>	168–336	–
1	Sub-Dominant Grasses & Grass-likes			942–1816	
	Grass, annual	2GA	<i>Grass, annual</i>	336–504	–
	Grass, perennial	2GP	<i>Grass, perennial</i>	336–504	–
	squirreltail	ELEL5	<i>Elymus elymoides</i>	34–101	–
	common spikerush	ELPA3	<i>Eleocharis palustris</i>	34–101	–
	slender wheatgrass	ELTR7	<i>Elymus trachycaulus</i>	34–101	–
	meadow barley	HOB2	<i>Hordeum brachyantherum</i>	34–101	–
	basin wildrye	LECI4	<i>Leymus cinereus</i>	34–101	–
	western wheatgrass	PASM	<i>Pascopyrum smithii</i>	34–101	–
	alpine timothy	PHAL2	<i>Phleum alpinum</i>	34–101	–
	weeping alkaligrass	PUDI	<i>Puccinellia distans</i>	34–101	–
Forb					
2	Sub-Dominant Forbs			336–504	
	Forb, annual	2FA	<i>Forb, annual</i>	336–504	–
	Forb, perennial	2FP	<i>Forb, perennial</i>	336–504	–
	common yarrow	ACMI2	<i>Achillea millefolium</i>	34–101	–
	silverweed cinquefoil	ARAN7	<i>Argentina anserina</i>	34–101	–
	field horsetail	EQAR	<i>Equisetum arvense</i>	34–101	–
	Nuttall's sunflower	HENU	<i>Helianthus nuttallii</i>	34–101	–
	Rocky Mountain iris	IRMI	<i>Iris missouriensis</i>	34–101	–
	yellow evening primrose	OEFL	<i>Oenothera flava</i>	34–101	–
	Rocky Mountain groundsel	PAST10	<i>Packera streptanthifolia</i>	34–101	–
	Utah buttercup	RAJO	<i>Ranunculus jovis</i>	34–101	–
	golden dock	RUMA4	<i>Rumex maritimus</i>	34–101	–
	seaside arrowgrass	TRMA20	<i>Triglochin maritima</i>	34–101	–

Animal community

This is one of Utah's highest yielding range sites. The plants are predominantly grasses and grasslike plants with a few forbs and practically no shrubs. To control soil erosion and degradation of the plant community this site may be properly grazed early with animals being removed early to allow key plants to go ungrazed during the last part of the growing season. A stubble height of 4 to 6 inches should be adhered to.

The potential is poor to fair for openland habitat, good to fair for woodland habitat, and good to fair for wetland habitat dependent on slope, and poor to fair for rangeland wildlife habitat.

It is good all around habitat for waterfowl and shorebirds, muskrats and beaver wherever it is adjacent to streams and ponds. It is fair for upland game birds and songbirds. It provides some feed for moose, elk and deer and brood rearing areas for sage grouse.

Hydrological functions

Soil series in this site are grouped mainly into D hydrologic group. These soils have high runoff potential. When the vegetation is in climax, the hydrologic curves are from 84 to 85. Refer to SCS national engineering handbook, section 4 to determine runoff quantities from these curves. When range condition has declined from the climax, field investigations are needed in order to determine hydrologic curve numbers. Use form UT-range-2 for this purpose.

Recreational uses

This site represents a view of lush, high producing vegetation primarily grasses and grass-like plants. It presents a pleasing view especially when livestock or big game are grazing it – one of a pleasant pastoral panorama. Fishing is opportune in adjacent lake and streams.

Wood products

None

Contributors

Garth W. Leishman, George Cook

Approval

Kirt Walstad, 3/01/2024

Rangeland health reference sheet

Interpreting Indicators of Rangeland Health is a qualitative assessment protocol used to determine ecosystem condition based on benchmark characteristics described in the Reference Sheet. A suite of 17 (or more) indicators are typically considered in an assessment. The ecological site(s) representative of an assessment location must be known prior to applying the protocol and must be verified based on soils and climate. Current plant community cannot be used to identify the ecological site.

Author(s)/participant(s)	Jack Alexander, Range Specialist, Synergy Resource Solutions, Inc. Julia Kluck, Soil Scientist, Synergy Resource Solutions, Inc. , Shane Green, NRCS
Contact for lead author	shane.green@ut.usda.gov
Date	02/07/2012
Approved by	Kirt Walstad
Approval date	

Indicators

- 1. Number and extent of rills:** No rills present. Very minor rill development may occur in sparsely vegetated areas. If rills are present, they should be widely spaced and not connected. Rill development may increase following large storm events, but should begin to heal during the following growing season. Frost heaving will accelerate recovery. Rill development may increase when run inflow enters site from adjacent sites that produce large amounts of runoff (i.e. steeper sites, slickrock, rock outcrop). Site is essentially level and rills do not form.

- 2. Presence of water flow patterns:** Water flow patterns will be very short (1-3'), narrow (<1'), and meandering; interrupted by plants and exposed rocks. Slight to no evidence of erosion or deposition associated with flow patterns. Where slopes exceed 5%, water flow patterns may be of medium length (5 –10 feet).

- 3. Number and height of erosional pedestals or terracettes:** Plants may have small pedestals (1-3") where they are adjacent to water flow patterns, but without exposed roots. Terracettes should be few and stable. Terracettes should be small (1-3") and show little sign of active erosion. Some plants may appear to have a pedestal but rather than be formed by erosion, they are the result of litter and soil accumulating at plant bases, forming the appearance of a pedestal.

- 4. Bare ground from Ecological Site Description or other studies (rock, litter, lichen, moss, plant canopy are not bare ground):** Essentially none. Litter or other ground cover fills all plant interspaces.

- 5. Number of gullies and erosion associated with gullies:** No gullies present. Site is essentially level, so no gullies are expected to form.

- 6. Extent of wind scoured, blowouts and/or depositional areas:** none

- 7. Amount of litter movement (describe size and distance expected to travel):** Most litter resides in place with some redistribution caused by water and wind movement. Very minor litter removal may occur in water flow paths with deposition occurring at points of obstruction. Where litter movement does occur, litter accumulates at plant bases. Some leaves, stems, and small twigs may accumulate in soil depressions adjacent to plants. Woody stems are not likely to move.

- 8. Soil surface (top few mm) resistance to erosion (stability values are averages - most sites will show a range of values):** This site should have an average erosion rating of 6 using the soil stability kit test.

- 9. Soil surface structure and SOM content (include type of structure and A-horizon color and thickness):** A--0 to 2 inches; pale brown (10YR 6/3) very fine sandy loam, brown (10YR 4/3) moist; weak fine granular structure; slightly hard, very friable, nonsticky and slightly plastic; many very fine, fine, and few medium roots; slightly effervescent, carbonates disseminated; strongly alkaline (pH 8.5); abrupt smooth boundary. (1 to 6 inches thick.)

-
10. **Effect of community phase composition (relative proportion of different functional groups) and spatial distribution on infiltration and runoff:** Bunchgrasses, rhizomatous grasses, and shrubs provide nearly continuous canopy cover, which effectively intercepts rainfall and protects soil from erosion. Extensive root systems provide ample organic matter to the soil, resulting in very high water-holding capacity. Infiltration rates vary with soil type, but the flat aspect and low-lying physiographic position favors surface ponding and gradual infiltration. Runoff is expected to be minimal.
-
11. **Presence and thickness of compaction layer (usually none; describe soil profile features which may be mistaken for compaction on this site):** A compaction layer is not expected.
-
12. **Functional/Structural Groups (list in order of descending dominance by above-ground annual-production or live foliar cover using symbols: >>, >, = to indicate much greater than, greater than, and equal to):**
- Dominant: Dominant: Grasslikes (sedges, mountain rush) > shrub-type willows (Booth's willow, Drummond's willow)
- Sub-dominant: Sub-dominant: Cool-season bunchgrasses (tufted hairgrass) > rhizomatous willows (narrowleaf willow)
- Other: Other: Forbs > other perennial grasses > other shrubs
- Additional:
-
13. **Amount of plant mortality and decadence (include which functional groups are expected to show mortality or decadence):** During years with average to above average precipitation, there should be very little recent mortality or decadence apparent in either the shrubs or grasses. Some mortality of bunchgrass and other shrubs may occur during very severe (long-term) droughts. There may be partial mortality of individual bunchgrasses and shrubs during less severe drought and toward the end of the fire cycle. Long-lived species dominate the site. Open spaces from disturbance are quickly filled by new plants through seedlings and asexual reproduction (tillering).
-
14. **Average percent litter cover (%) and depth (in):** Litter cover includes litter under plants. Most litter will be fine (herbaceous) litter. Litter will be concentrated under plant canopies and sparser between plant canopies, with an average cover of 20-40% and an average depth of 0.75-1.5 inches. Litter cover may increase following years with favorable growing conditions. Excess litter may accumulate in absence of disturbance. Vegetative production may be reduced if litter cover exceeds 40%.
-
15. **Expected annual annual-production (this is TOTAL above-ground annual-production, not just forage annual-production):** 2050-3050 lbs/acre.
- Even the most stable communities exhibit a range of production values. Production will vary between communities and across the MRLA. Refer to the community descriptions in the ESD. Production will differ across the MLRA due to the naturally occurring variability in weather, soils, and aspect. The biological processes on this site are complex; therefore, representative values are presented in a land management context.
-
16. **Potential invasive (including noxious) species (native and non-native). List species which BOTH characterize degraded states and have the potential to become a dominant or co-dominant species on the ecological site if**

their future establishment and growth is not actively controlled by management interventions. Species that become dominant for only one to several years (e.g., short-term response to drought or wildfire) are not invasive plants. Note that unlike other indicators, we are describing what is NOT expected in the reference state for the ecological site: Canada thistle, elk thistle, musk thistle

17. **Perennial plant reproductive capability:** All perennial plants should have the ability to reproduce sexually or asexually, except in drought years. Density of plants indicates that plants reproduce at level sufficient to fill available resource. Within capability of site there are no restrictions on seed or vegetative reproductive capacity.
-