

Ecological site R048AY410UT Mountain Loamy Bottom (Basin Wildrye)

Last updated: 3/01/2024
Accessed: 05/03/2024

General information

Provisional. A provisional ecological site description has undergone quality control and quality assurance review. It contains a working state and transition model and enough information to identify the ecological site.

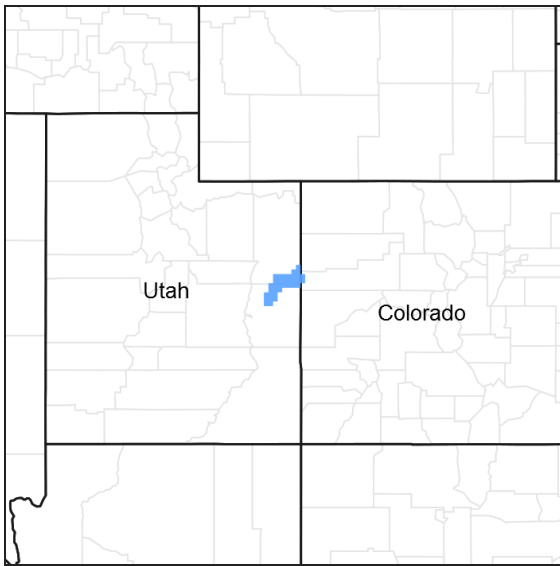

Figure 1. Mapped extent

Areas shown in blue indicate the maximum mapped extent of this ecological site. Other ecological sites likely occur within the highlighted areas. It is also possible for this ecological site to occur outside of highlighted areas if detailed soil survey has not been completed or recently updated.

MLRA notes

Major Land Resource Area (MLRA): 048A–Southern Rocky Mountains

MLRA 48A makes up about 45,920 square miles (119,000 square kilometers) and is the southern part of the Rocky Mountains. The Southern Rocky Mountains lies east of the Colorado Plateau, south of the Wyoming Basin, west of the Great Plains, and north of the Rio Grande Rift. It is in western and central Colorado, southeastern Wyoming, eastern Utah, and northern New Mexico. The headwaters of major rivers such as the Colorado, Yampa, Arkansas, Rio Grande, North Platte and South Plate rivers are located here. This MLRA has numerous national forests, including the Medicine Bow National Forest in Wyoming; the Routt, Arapaho, Roosevelt, Pike, San Isabel, White River, Gunnison, Grand Mesa, Uncompahgre, Rio Grande, and San Juan National Forests in Colorado; the Carson National Forest and part of the Santa Fe National Forest in New Mexico. Rocky Mountain National Park also is in this MLRA.

MLRA 48A is the southern Rocky Mountains physiographic region. The Southern Rocky Mountains consist primarily of two belts of strongly sloping to precipitous mountain ranges trending north to south. Several basins, or parks, are between the belts. Some high mesas and plateaus are included. It is characterized by mountain ranges that were uplifted during the Laramide Orogeny and then had periods of glaciation. The ranges include the Sangre de Cristo Mountains, the Laramie Mountains, and the Front Range in the east and the San Juan Mountains and the Sawatch and Park Ranges in the west. The ranges are dissected by many narrow stream valleys having steep gradients. In some areas the upper mountain slopes and broad crests are covered by snowfields and glaciers. Elevation typically

ranges from 6,500 to 14,400 feet (1,980 to 4,390 meters) in this area. The part of this MLRA in central Colorado includes the highest point in the Rockies, Mount Elbert, which reaches an elevation of 14,433 feet (4,400 meters). More than 50 peaks in the part of the MLRA in Colorado are at an elevation of more than 14,000 feet (4,270 meters). Many small glacial lakes are in the high mountains.

The mountains in this area were formed mainly by crustal uplifts during the late Cretaceous and early Tertiary periods. This large MLRA can be subdivided into at least 4 large general divisions. First is the Rockies on the east side of this area are called the "Front Range," which is a fault block that has been tilted up on edge and uplifted and is largely igneous and metamorphic geology. It was tilted up on the east edge, so there is a steep front on the east and the west side is more gently sloping and in the south east there are rocks exposed in the mountains are mostly Precambrian igneous and metamorphic rocks. Second is the tertiary rocks, primarily basalt and andesitic lava flows, tuffs, breccias, and conglomerates, are throughout this area (San Juan Mountains Area). The third division is Northwest part of the MLRA is dominantly sedimentary rock from the cretaceous/tertiary and Permian/Pennsylvanian periods. The fourth subset is the long and narrow Sangre de Cristos mountains uplifted in the Cenozoic are between the Rio Grande rift and the great plains. Many of the highest mountain ranges were reshaped by glaciation during the Pleistocene. Alluvial fans at the base of the mountains are recharge zones for local basin and valley fill aquifers. They also are important sources of sand and gravel.

The average annual precipitation ranges predominantly from 12 to 63 inches. Summer rainfall commonly occurs as high-intensity, convective thunderstorms. About half of the annual precipitation occurs as snow in winter; this proportion increases with elevation. In the mountains, deep snowpacks accumulate throughout the winter and generally persist into spring or early summer, depending on elevation. Some permanent snowfields and small glaciers are on the highest mountain peaks. In the valleys at the lower elevations, snowfall is lighter and snowpacks can be intermittent. The average annual temperature is 26 to 54 degrees F (-3 to 12 degrees C). The freeze-free period averages 135 days and ranges from 45 to 230 days, decreasing in length with elevation. The climate of this area is strongly dependent upon elevation; precipitation is greater, and temperatures are cooler at the higher elevations. The plant communities vary with elevation, aspect and change in latitudes due to changing in precipitation kind and timing and temperature.

The dominant soil orders in this MLRA are Mollisols, Alfisols, Inceptisols, and Entisols. The soils in the area dominantly have a frigid or cryic soil temperature regime and an ustic or udic soil moisture regime. Mineralogy is typically mixed, smectitic, or paramicaceous. In areas with granite, gneiss, and schist bedrock, Glossocryalfs (Seitz, Granile, and Leadville series) and Haplocryolls (Rogert series) formed in colluvium on mountain slopes. Dystrocryepts (Leighcan and Mummy series) formed on mountain slopes and summits at the higher elevations. In areas of andesite and rhyolite bedrock, Dystrocryepts (Endlich and Whitecross series) formed in colluvium on mountain slopes. In areas of sedimentary bedrock, Haplustolls (Towave series) formed on mountain slopes at low elevations and with low precipitation. Haplocryolls (Lamphier and Razorba series), Argicryolls (Cochetopa series), and Haplocryalfs (Needleton series) formed in colluvium on mountain slopes at high elevations.

Ecological site concept

The soils of this site formed mostly in alluvium derived from limestone, sandstone, and shale. Surface soils are loam to sandy loam in texture. Rock fragments may be present on the soil surface and throughout the profile, but make up less than 35 percent of the soil volume. These soils are deep to very deep, well-drained, and have moderate to moderately rapid permeability. pH is slightly to moderately alkaline. Available water-holding capacity ranges from 4 to 8 inches of water in the upper 60 inches of soil. The soil moisture regime is mostly ustic and the soil temperature regime is frigid. Precipitation ranges from 16 to 22 inches annually.

Associated sites

R048AY006UT	Semiwet Fresh Streambank
R048AY409UT	Mountain Loam (Salina Wildrye)
R048AY448UT	Mountain Stony Loam (Mountain Big Sagebrush)

Similar sites

Table 1. Dominant plant species

Tree	Not specified
Shrub	(1) <i>Artemisia tridentata ssp. tridentata</i>
Herbaceous	(1) <i>Leymus cinereus</i>

Physiographic features

This ecological site typically is on stream terraces and drainageways. Sites are located between 6,100 to 8,500 feet in elevation. Slopes normally range from 3 to 15 percent.

Table 2. Representative physiographic features

Landforms	(1) Drainageway (2) Stream terrace
Runoff class	Low
Flooding duration	Extremely brief (0.1 to 4 hours) to brief (2 to 7 days)
Flooding frequency	None to very rare
Ponding frequency	None
Elevation	1,859–2,591 m
Slope	3–15%
Ponding depth	Not specified
Water table depth	Not specified

Climatic features

Average annual precipitation is 16 to 22 inches. Approximately 55 percent occurs as rain from may through october. On the average, november through june are the driest months and july through october are the wettest months. Cool temperatures and length of growing season are important environmental factors in this site. In average years, plants begin growth around april 20 and end growth around september 30.

Table 3. Representative climatic features

Frost-free period (characteristic range)	60-90 days
Freeze-free period (characteristic range)	
Precipitation total (characteristic range)	406-559 mm

Influencing water features

This site receives run-in water from adjacent upland landscapes.

Soil features

The soils of this site formed mostly in alluvium derived from limestone, sandstone, and shale. Surface soils are loam to sandy loam in texture. Rock fragments may be present on the soil surface and throughout the profile, but make up less than 35 percent of the soil volume. These soils are deep to very deep, well-drained, and have moderate to moderately rapid permeability. pH is slightly to moderately alkaline. Available water-holding capacity ranges from 4 to 8 inches of water in the upper 60 inches of soil. The soil moisture regime is mostly ustic and the soil temperature regime is frigid. Precipitation ranges from 16-22 inches annually.

Table 4. Representative soil features

Parent material	(1) Alluvium–limestone, sandstone, and shale
Surface texture	(1) Loam (2) Sandy loam
Family particle size	(1) Fine-loamy (2) Coarse-loamy
Drainage class	Well drained
Permeability class	Moderate to moderately rapid
Depth to restrictive layer	152–254 cm
Soil depth	152–254 cm
Surface fragment cover <=3"	3–11%
Surface fragment cover >3"	0%
Available water capacity (Depth not specified)	10.16–20.32 cm
Calcium carbonate equivalent (Depth not specified)	0–15%
Electrical conductivity (Depth not specified)	0–2 mmhos/cm
Sodium adsorption ratio (Depth not specified)	0–3
Soil reaction (1:1 water) (Depth not specified)	7.9–8.4
Subsurface fragment volume <=3" (Depth not specified)	8–10%
Subsurface fragment volume >3" (Depth not specified)	1–3%

Ecological dynamics

It is impossible to determine in any quantitative detail the historic climax plant community (HCPC) for this ecological site because of the lack of direct historical documentation preceding all human influence. In some areas, the earliest reports of dominant plants include the cadastral survey conducted by the General Land Office, which began in the late 19th century for this area (Galatowitsch 1990). However, up to the 1870s the Shoshone Indians, prevalent in northern Utah and neighboring states, grazed horses and set fires to alter the vegetation for their needs (Parson 1996). In the 1860s, Europeans brought cattle and horses to the area, grazing large numbers of them on unfenced parcels year-long (Parson 1996). Itinerant and local sheep followed, largely replacing cattle as the browse component increased.

Below is a State and Transition Model diagram to illustrate the “phases” (common plant communities), and “states” (aggregations of those plant communities) that can occur on the site. Differences between phases and states depend primarily upon observations of a range of disturbance histories in areas where this ESD is represented. These situations include grazing gradients to water sources, fence-line contrasts, patches with differing dates of fire, herbicide treatment, tillage, etc. Reference State 1 illustrates the common plant communities that probably existed just prior to European settlement.

The major successional pathways within states, (“community pathways”) are indicated by arrows between phases. “Transitions” are indicated by arrows between states. The drivers of these changes are indicated in codes decipherable by referring to the legend at the bottom of the page and by reading the detailed narratives that follow the diagram. The transition between Reference State 1 and State 2 is considered irreversible because of the naturalization of exotic species of both flora and fauna, possible extinction of native species, and climate change.

There may have also been accelerated soil erosion.

When available, monitoring data (of various types) were employed to validate more subjective inferences made in this diagram. See the complete files in the office of the State Range Conservationist for more details.

The plant communities shown in this State and Transition Model may not represent every possibility, but are probably the most prevalent and recurring plant communities. As more monitoring data are collected, some phases or states may be revised, removed, and/or new ones may be added. None of these plant communities should necessarily be thought of as "Desired Plant Communities." According to the USDA NRCS National Range & Pasture Handbook (USDA-NRCS 2003), Desired Plant Communities (DPC's) will be determined by the decision-makers and will meet minimum quality criteria established by the NRCS. The main purpose for including descriptions of a plant community is to capture the current knowledge at the time of this revision.

State 1: Reference State

The Reference State is a description of this ecological site just prior to Euro-American settlement but long after the arrival of Native Americans. The description of the Reference State was determined by NRCS Soil Survey Type Site Location information and familiarity with rangeland relict areas where they exist. The Reference State for this site would have been characterized as a shrub steppe co-dominated by basin big sagebrush (*Artemisia tridentata* ssp. *tridentata*), the dominant shrub, and having a rich herbaceous understory. The proportions of shrubs and herbs would have been dependent upon the length of time elapsed since the last wildfire or other sagebrush-killing event. If fire had not occurred within the past 30 years (1.2a), basin big sagebrush would have been the dominant shrub, having a native perennial herbaceous understory (1.1). If less than 10 years had elapsed since the last fire (1.1a), perennial native herbs would have increased and the shrub component would have been dominated by root-sprouting species such as rubber rabbitbrush (*Ericameria nauseosa*), and yellow rabbitbrush (*Chrysothamnus viscidiflorus*) (1.2). Soil anoxia from extremely wet years or an outbreak of Aroga (Aroga spp.) moth (1.1b) could have also reduced sagebrush and enhanced root-sprouting shrubs and perennial herbs (1.2) in some years. The same effect would have also been achieved by parch blight due to lack of snow cover during dry, cold winters (1.1c). A more complete list of species by lifeform for the Reference State is available in the accompanying tables in the "Plant Community Composition by Weight and Percentage" section of this document.

Community Phase 1.1: Basin big sagebrush/ abundant native perennial herbs

This plant community would have developed in the absence of recent fire and was characterized by basin big sagebrush and abundant native perennial herbs. Primary bunchgrasses would have included needle-and-thread (*Hesperostipa comata*), Indian ricegrass (*Achnatherum hymenoides*), and basin wildrye (*Leymus cinereus*).

Community Pathway 1.1a

Wildfire would have removed basin big sagebrush, allowing root-sprouting shrubs and the native perennial forbs and grasses to increase.

Community Pathway 1.1b

An extremely wet period such as an El Nino-Southern Oscillation event and subsequent anoxic soil conditions would have killed off basin big sagebrush and converted the plant community to one dominated by root-sprouting shrubs and native perennial herbs. The same result would have been seen following a sudden insect (e.g. Aroga moth), or other pathogen outbreak on sagebrush.

Community Pathway 1.1c

Unusually cold, dry winters may have caused severe parch blight, killing off substantial portions of sagebrush and allowing roots-sprouting shrubs and native perennial herbs to dominate the plant community.

Community Phase 1.2: root-sprouting shrubs/ increased perennial herbs

This phase of the Reference State would have been dominated by root-sprouting shrubs such as rubber rabbitbrush, and yellow rabbitbrush, with a rich understory of native perennial herbs.

Community Pathway 1.2a

In the absence of fire, this plant community would have responded with an increase in basin big sagebrush and a corresponding decrease in native perennial herbs.

T1a: Transition from State 1 to State 2 (Reference State to Basin Big Sagebrush/ Introduced Non-natives State)

The simultaneous introduction of exotic species, both plants and animals, and possible extinctions, along with climate change, has caused State 1 to transition to State 2. Reversal of such historic changes (i.e. a return pathway) back to State 1 is not practical.

State 2: Basin Big Sagebrush/ Introduced Non-native Herbs State

State 2 is very similar to State 1 in form and function, with the exception of the presence of non-native plants and animals, possible extinctions of native species, and a different climate. State 2 is a description of the ecological site shortly following Euro-American settlement. This State can be regarded as the current potential. As with State 1, a shift will be seen in the abundance of basin big sagebrush relative to the perennial herbs based upon the amount of time that has elapsed since the last wildfire or other sagebrush-killing event. Wildfire (2.1a) will temporarily remove basin big sagebrush, allowing root-sprouting shrubs and all types of herbs (both native and non-native) to increase (2.2). Lack of fire (2.2a) will favor the return of basin big sagebrush provided that there is adequate seed source from adjacent unburned areas. Perennial native herbs and non-native annuals will maintain their presence post-fire. Other drivers that could reduce sagebrush and favor root-sprouting shrubs (2.2) include anoxic soils from extremely wet years, outbreaks of Aroga moth (2.1b), or parch blight due to lack of snow cover during dry cold winters (2.1c). The resiliency of this State is maintained by a healthy, productive, and diverse plant community that can provide native seed sources and promotes soil stability, water infiltration, and soil moisture retention. The resiliency of this State can be maintained by reducing livestock grazing impacts, especially during the growing season of perennial herbs. Conversely, continued heavy grazing will negatively impact the resiliency of this State.

Community Phase 2.1: Basin big sagebrush/ abundant native perennial herbs

This plant community will develop in the absence of fire and is characterized by basin big sagebrush with an understory made up of both native perennial and introduced herbs. Bunchgrasses include needle-and-thread, Indian ricegrass, and basin wildrye. Common invaders are cheatgrass and Russian thistle.

Community Pathway 2.1a

Wildfire will remove basin big sagebrush, allowing root-sprouting shrubs and the native perennial forbs and grasses to increase.

Community Pathway 2.1b

An extremely wet period such as an El Nino-Southern Oscillation event and subsequent anoxic soil conditions can kill basin big sagebrush and convert the plant community to one dominated by root-sprouting shrubs and native perennial herbs. The same result would be seen following a sudden insect (e.g. Aroga moth) or other pathogen outbreak on sagebrush.

Community Pathway 2.1c

Unusually cold, dry winters may cause severe parch blight, killing substantial portions of sagebrush and allowing roots-sprouting shrubs and native perennial herbs to dominate the plant community.

Community Phase 2.2: root-sprouting shrubs/ increased native perennial herbs

This plant community is dominated by root-sprouting shrubs such as rubber rabbitbrush, and yellow rabbitbrush with a rich understory of native perennial herbs.

Community Pathway 2.2a

In the absence of fire, this plant community will respond with an increase in basin big sagebrush and a corresponding decrease in native perennial herbs.

T2a: Transition from State 2 to State 3 (Basin Big Sagebrush/ Introduced Non-native Herbs State to Brush Super-dominance State)

The Basin Big Sagebrush/ Introduced Non-natives State will transition to the Brush Super-dominance State following excessive livestock grazing, particularly during the growing season of herbs. Native perennial herbs are eventually depleted such that mere reduction or removal of livestock will not allow for their recovery. The approach to this transition is indicated by the dominance of large, old sagebrush. This transition can be avoided by removal or reduction of sagebrush by prescribed fire, herbicides, or mechanical means well before the diminishment of native perennial herbs has occurred.

State 3: Brush Super-dominance State

With multiple-year heavy livestock grazing, especially during the growing season, native perennial herbs are

diminished. Once the soil seed reserve is exhausted, there is little opportunity for recovery. In the absence of fire (3.2a) basin big sagebrush will begin to dominate (3.1). Where mechanical or fire damage occur to the non-sprouting basin big sagebrush (3.1a), root-sprouting shrubs can increase (3.2). The state is maintained by the lack of a healthy, productive and diverse herb component capable of providing native seed source, soil stabilization, and soil moisture retention.

Community Phase 3.1: Basin big sagebrush super-dominance

This plant community is characterized as a basin big sagebrush-dominated site where the understory is greatly diminished in species richness and abundance from heavy continuous livestock grazing and lack of fire.

Community Pathway 3.1a

Wildfire or mechanical removal of sagebrush will develop a plant community dominated by root-sprouting shrubs.

Community Phase 3.2: Root-sprouting shrubs super-dominance

As the site deteriorates from heavy continuous livestock grazing compounded by fire or mechanical removal of sagebrush, the plant community will become dominated by root-sprouting shrubs such as rubber rabbitbrush, and yellow rabbitbrush.

Community Pathway 3.2a

After an extended period without wildfire, provided a viable seed source is available, basin big sagebrush will begin to re-establish and dominate the site.

T3a: Transition from State 3 to State 4 (Brush Super-dominance State to Seeded State)

Because reduction or exclusion of livestock use will not allow ready recovery of the herbaceous understory in State 3, the manager is left with few options to increase the perennial herbaceous cover. Tillage followed by re-seeding is the usual action required. Thus, the transition from a Brush Super-dominance State (regardless of phase) to the Seeded State is commonly seen.

State 4: Seeded State

The most common seedings of the past have been to Eurasian wheatgrasses (*Agropyron* spp.) or ryegrasses (*Elymus* spp.) (4.1). Where tillage has been employed, the native forbs and browse have most likely been destroyed. Thus, if a more diverse plant community is required (4.2), other species will have to be added to the seed mix and utilization by livestock deferred for several years (4.1a). In some circumstances, the native forbs and shrubs will slowly re-establish (4.2 and 4.3) when adjacent area have not been tilled. Subsequent re-treatment with herbicide or mechanical (e.g. Lawson pasture-aerator) action (4.2a and 4.3a) will be necessary to maintain grass dominance (4.1). Once a site is re-established with forbs and shrubs (4.2) and a sufficient length of time has elapsed since the last fire (4.2b), pioneering shrubs such as rubber rabbitbrush, and yellow rabbitbrush may dominate the site (4.3). Returning to a more diverse plant community (4.2) may require mechanically removing some shrubs and re-seeding (4.3b). This State can be maintained by moderate levels of livestock use or alteration of dates of use, particularly during the boot stage of the grass. Heavy spring use by livestock will reduce the resiliency of this State.

Community Phase 4.1: crested wheatgrass monoculture

This plant community is predominantly a monoculture of a seeded species, commonly crested wheatgrass (*Agropyron cristatum*).

Community Pathway 4.1a

Re-seeding with a mix of forbs and shrubs combined with limited use/prescribed grazing by livestock will be necessary to facilitate the re-establishment of a more diverse plant community.

Community Phase 4.2: re-invaded herbs and shrubs

This plant community is characterized by a mix of native and non-native herbs and shrubs that have re-invaded or been seeded into the site. Disturbance follower species that may be present include rubber rabbitbrush, yellow rabbitbrush, and Russian thistle (*Salsola* sp.). Other re-invaders could also include bulbous bluegrass (*Poa bulbosa*), Sandberg bluegrass (*Poa secunda*), or Kentucky bluegrass (*Poa pratensis*).

Community Pathway 4.2a

Either mechanical or chemical brush management will be required to maintain a grass-dominated site.

Community Pathway 4.2b

The absence of fire will shift this community into a re-invaded shrub-dominated site.

Community Phase 4.3: re-invaded shrub dominance

Disturbance following shrubs such as rubber rabbitbrush, and yellow rabbitbrush may dominate the site in the absence of fire.

Community Pathway 4.3a

Either mechanical or chemical brush management will be required to maintain a grass-dominated site.

Community Pathway 4.3b

Mechanically removing some shrubs and re-seeding with a diverse mixture of forbs and grasses will improve the balance between the herbaceous and shrub components.

State and transition model

4. Seeded State

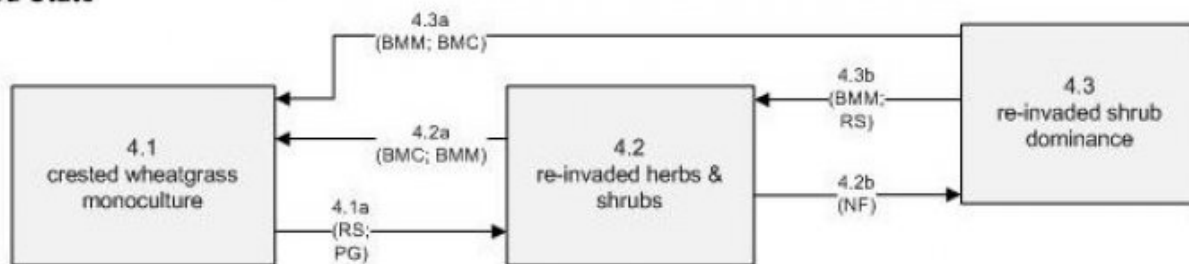

3. Brush Super-dominance State

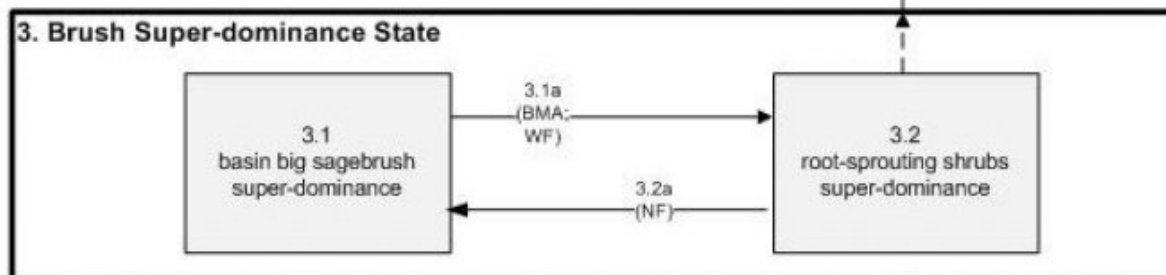

2. Basin Big Sagebrush/ Introduced Non-native Herbs State

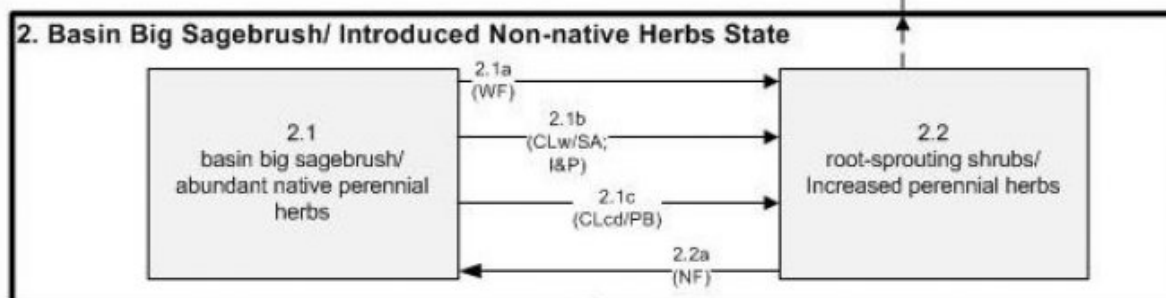

1. Reference State

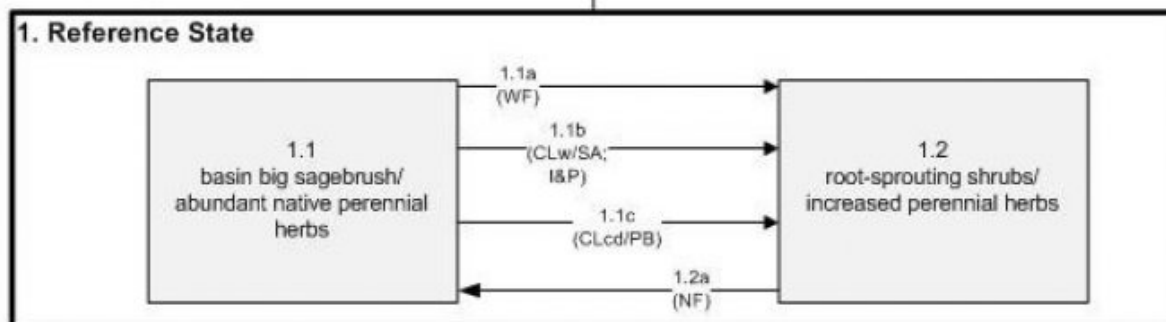

BMA	Brush Management All (Chemical, Fire, Mechanical)
BMC	Brush Management (Chemical)
BMM	Brush Management (Mechanical)
CLcd	Climate (unusually cold and dry)
CLw	Climate (unusually wet)
HC	Historic Change
HCSLG	Heavy Continuous Season Long Grazing
I&P	Insects & (Other) Pathogens

NF	No Fire
PB	Parch Blight
PG	Prescribed Grazing
RS	Re-seed
SA	Soil Anoxia
Till	Tillage
WF	Wildfire

State 1
Reference State

Community 1.1 Reference Plant Community

The general view of this site is basin wildrye and basin big sagebrush. The potential natural plant community is composed of approximately 65 percent perennial grasses, 10 percent forbs and 25 percent shrubs by air-dry weight.

Table 5. Annual production by plant type

Plant Type	Low (Kg/Hectare)	Representative Value (Kg/Hectare)	High (Kg/Hectare)
Grass/Grasslike	1056	1420	2149
Shrub/Vine	407	547	827
Forb	163	219	331
Total	1626	2186	3307

Table 6. Ground cover

Tree foliar cover	0%
Shrub/vine/liana foliar cover	19-21%
Grass/grasslike foliar cover	49-51%
Forb foliar cover	4-6%
Non-vascular plants	0%
Biological crusts	0%
Litter	0%
Surface fragments >0.25" and <=3"	0%
Surface fragments >3"	0%
Bedrock	0%
Water	0%
Bare ground	0%

Table 7. Canopy structure (% cover)

Height Above Ground (M)	Tree	Shrub/Vine	Grass/ Grasslike	Forb
<0.15	–	–	–	–
>0.15 <= 0.3	–	–	–	4-6%
>0.3 <= 0.6	–	–	–	–
>0.6 <= 1.4	–	–	–	–
>1.4 <= 4	–	19-21%	49-51%	–
>4 <= 12	–	–	–	–
>12 <= 24	–	–	–	–
>24 <= 37	–	–	–	–
>37	–	–	–	–

Additional community tables

Table 8. Community 1.1 plant community composition

Group	Common Name	Symbol	Scientific Name	Annual Production (Kg/Hectare)	Foliar Cover (%)
Shrub/Vine					

0	Dominant Shrubs			291–448	
	basin big sagebrush	ARTRT	<i>Artemisia tridentata</i> ssp. <i>tridentata</i>	224–336	–
	mountain snowberry	SYOR2	<i>Symphoricarpos oreophilus</i>	67–112	–
3	Sub-Dominant Shrubs			269–695	
	Shrub (>.5m)	2SHRUB	<i>Shrub (>.5m)</i>	112–224	–
	Utah serviceberry	AMUT	<i>Amelanchier utahensis</i>	22–67	–
	prairie sagewort	ARFR4	<i>Artemisia frigida</i>	22–67	–
	yellow rabbitbrush	CHVI8	<i>Chrysothamnus viscidiflorus</i>	22–67	–
	rubber rabbitbrush	ERNA10	<i>Ericameria nauseosa</i>	22–67	–
	sulphur-flower buckwheat	ERUM	<i>Eriogonum umbellatum</i>	22–67	–
	plains pricklypear	OPPO	<i>Opuntia polyacantha</i>	22–67	–
	blue elderberry	SANIC5	<i>Sambucus nigra</i> ssp. <i>cerulea</i>	22–67	–
Grass/Grasslike					
0	Dominant Grasses			897–1457	
	basin wildrye	LECI4	<i>Leymus cinereus</i>	448–560	–
	saline wildrye	LESAS	<i>Leymus salinus</i> ssp. <i>salinus</i>	112–224	–
	muttongrass	POFE	<i>Poa fendleriana</i>	112–224	–
	mountain brome	BRMA4	<i>Bromus marginatus</i>	112–224	–
	needle and thread	HECO26	<i>Hesperostipa comata</i>	112–224	–
1	Sub-Dominant Grasses			695–1233	
	Grass, annual	2GA	<i>Grass, annual</i>	112–224	–
	Grass, perennial	2GP	<i>Grass, perennial</i>	112–224	–
	Indian ricegrass	ACHY	<i>Achnatherum hymenoides</i>	67–112	–
	Letterman's needlegrass	ACLE9	<i>Achnatherum lettermanii</i>	67–112	–
	Columbia needlegrass	ACNE9	<i>Achnatherum nelsonii</i>	67–112	–
	Ross' sedge	CARO5	<i>Carex rossii</i>	67–112	–
	squirreltail	ELEL5	<i>Elymus elymoides</i>	67–112	–
	slender wheatgrass	ELTR7	<i>Elymus trachycaulus</i>	67–112	–
	western wheatgrass	PASM	<i>Pascopyrum smithii</i>	67–112	–
Forb					
2	Sub-Dominant Forbs			224–448	
	Forb, annual	2FA	<i>Forb, annual</i>	112–224	–
	Forb, perennial	2FP	<i>Forb, perennial</i>	112–224	–
	common yarrow	ACMI2	<i>Achillea millefolium</i>	22–45	–
	white sagebrush	ARLU	<i>Artemisia ludoviciana</i>	22–45	–
	Wyoming Indian paintbrush	CALI4	<i>Castilleja linariifolia</i>	22–45	–
	woodland strawberry	FRVE	<i>Fragaria vesca</i>	22–45	–
	sticky purple geranium	GEVI2	<i>Geranium viscosissimum</i>	22–45	–
	tailcup lupine	LUCAC3	<i>Lupinus caudatus</i> ssp. <i>caudatus</i>	22–45	–
	lobeleaf groundsel	PAMU11	<i>Packera multilobata</i>	22–45	–
	slender cinquefoil	POGR9	<i>Potentilla gracilis</i>	22–45	–
	scarlet globemallow	SPCO	<i>Sphaeralcea coccinea</i>	22–45	–

	common dandelion	TAOF	<i>Taraxacum officinale</i>	22-45	-
	American vetch	VIAM	<i>Vicia americana</i>	22-45	-

Animal community

Basin wildrye is a moderately palatable, long-lived grass (Welsh et al: A Utah Flora pg. 723).

This site provides food and cover for Several species of wildlife. Wildlife using this site include sage grouse, coyote, rabbit, mule deer and elk.

Hydrological functions

The soil series in this site are in hydrologic groups B and C. The runoff curve numbers are 61 through 86 depending on the condition of the watershed.

Recreational uses

This site has aesthetic appeal because of increased production due to more moisture that adjacent land. Recreation values include hiking and hunting.

Wood products

None

Contributors

Garth W. Leishman, Lars Rassmussen

Approval

Kirt Walstad, 3/01/2024

Rangeland health reference sheet

Interpreting Indicators of Rangeland Health is a qualitative assessment protocol used to determine ecosystem condition based on benchmark characteristics described in the Reference Sheet. A suite of 17 (or more) indicators are typically considered in an assessment. The ecological site(s) representative of an assessment location must be known prior to applying the protocol and must be verified based on soils and climate. Current plant community cannot be used to identify the ecological site.

Author(s)/participant(s)	
Contact for lead author	
Date	03/12/2020
Approved by	Kirt Walstad
Approval date	
Composition (Indicators 10 and 12) based on	Annual Production

Indicators

1. **Number and extent of rills:** No rills present. Very minor rill development may occur in sparsely vegetated areas. If rills are present, they should be widely spaced and not connected. Rill development may increase following large storm events, but should begin to heal during the following growing season. Frost heaving will accelerate recovery. Rill development may increase when run inflow enters site from adjacent sites that produce large amounts of runoff (i.e.

steeper sites, slickrock, rock outcrop). Site is essentially level and rills do not form.

2. **Presence of water flow patterns:** Few originating on this site. Flow patterns meander around rocks, litter, and perennial plant bases. They may be long (10-20'), but remain less than 1' wide, and are widely spaced (5-15' apart). They are stable with only minor evidence of deposition. This site is periodically inundated with runoff water due to its physiographic location.

3. **Number and height of erosional pedestals or terracettes:** Plants may have small pedestals (1-3") where they are adjacent to water flow patterns, but without exposed roots. Terracettes should be few and stable. Terracettes should be small (1-3") and show little sign of active erosion. Some plants may appear to have a pedestal but rather than be formed by erosion, they are the result of litter and soil accumulating at plant bases, forming the appearance of a pedestal.

4. **Bare ground from Ecological Site Description or other studies (rock, litter, lichen, moss, plant canopy are not bare ground):** Essentially none. Litter or other ground cover fills all plant interspaces.

5. **Number of gullies and erosion associated with gullies:** Site is essentially level, so no gullies are expected to form.

6. **Extent of wind scoured, blowouts and/or depositional areas:** Very minor evidence of active wind-generated soil movement. Wind scoured (blowouts) and depositional areas are rarely present. If present they have muted features and are mostly stabilized with vegetation and/or biological crust.

7. **Amount of litter movement (describe size and distance expected to travel):** Most litter resides in place with some redistribution caused by water and wind movement. Very minor litter removal may occur in water flow paths with deposition occurring at points of obstruction. Where litter movement does occur, litter accumulates at plant bases. Some leaves, stems, and small twigs may accumulate in soil depressions adjacent to plants. Woody stems are not likely to move.

8. **Soil surface (top few mm) resistance to erosion (stability values are averages - most sites will show a range of values):** This site should have an average erosion rating of 6 using the soil stability kit test.

9. **Soil surface structure and SOM content (include type of structure and A-horizon color and thickness):** A1--0 to 3 inches; grayish brown (10YR 5/2) sandy loam, very dark grayish brown (10YR 3/2) moist; weak medium subangular blocky structure; soft, friable, slightly sticky and nonplastic; many fine and very fine roots; few fine tubular pores; very slightly effervescent, (2 percent calcium carbonate equivalent), carbonates are disseminated; moderately alkaline (pH 8.2); clear smooth boundary. (3 to 8 inches thick)

10. **Effect of community phase composition (relative proportion of different functional groups) and spatial distribution on infiltration and runoff:** Bunchgrasses and shrubs are equally important for increasing infiltration and reducing runoff. Plant litter and canopy cover from all functional groups intercept rainfall and prevent splash erosion. Bunchgrasses contribute organic matter directly to soil through root decay, and organic matter helps stabilize soil

aggregates and maintain soil porosity. Shrubs hold snow and slow wind evaporation. Bunchgrass bases intercept litter and soil in water flow paths, reducing runoff. Biological soil crusts (where present) are resistant to raindrop impact and splash erosion. Spatial distribution of vascular plants and well-developed biological soil crusts (where present) provides detention storage and surface roughness that slows runoff allowing time for infiltration. Interspaces between plants and any well-developed biological soil crusts (where present) may serve as water flow patterns during episodic runoff events, with natural erosion expected in severe storms.

11. **Presence and thickness of compaction layer (usually none; describe soil profile features which may be mistaken for compaction on this site):** A compaction layer is not expected.
-

12. **Functional/Structural Groups (list in order of descending dominance by above-ground annual-production or live foliar cover using symbols: >>, >, = to indicate much greater than, greater than, and equal to):**

Dominant: Dominant: Tall perennial cool-season bunchgrass (basin wildrye) > non-sprouting shrubs (basin big sagebrush)

Sub-dominant: Sum-dominant: Perennial cool-season bunchgrasses (California brome, needle and thread, saline wildrye, muttongrass) > sprouting shrubs (mountain snowberry)

Other: Other: Other perennial grasses = perennial forbs > other shrubs

Additional:

13. **Amount of plant mortality and decadence (include which functional groups are expected to show mortality or decadence):** During years with average to above average precipitation, there should be very little recent mortality or decadence apparent in either the shrubs or grasses. Some mortality of bunchgrass and other shrubs may occur during very severe (long-term) droughts. There may be partial mortality of individual bunchgrasses and shrubs during less severe drought and toward the end of the fire cycle. Long-lived species dominate the site. Open spaces from disturbance are quickly filled by new plants through seedlings and asexual reproduction (tillering).
-

14. **Average percent litter cover (%) and depth (in):** Litter cover includes litter under plants. Most litter will be fine (herbaceous) litter. Litter will be concentrated under plant canopies and sparser between plant canopies, with an average cover of 20-40% and an average depth of 0.75-1.5 inches. Litter cover may increase following years with favorable growing conditions. Excess litter may accumulate in absence of disturbance. Vegetative production may be reduced if litter cover exceeds 40%.
-

15. **Expected annual annual-production (this is TOTAL above-ground annual-production, not just forage annual-production):** 1900-2000 lbs/acre.

Even the most stable communities exhibit a range of production values. Production will vary between communities and across the MRLA. Refer to the community descriptions in the ESD. Production will differ across the MLRA due to the naturally occurring variability in weather, soils, and aspect. The biological processes on this site are complex; therefore, representative values are presented in a land management context.

16. **Potential invasive (including noxious) species (native and non-native). List species which BOTH characterize degraded states and have the potential to become a dominant or co-dominant species on the ecological site if**

their future establishment and growth is not actively controlled by management interventions. Species that become dominant for only one to several years (e.g., short-term response to drought or wildfire) are not invasive plants. Note that unlike other indicators, we are describing what is NOT expected in the reference state for the ecological site: Cheatgrass, halogeton, kochia, Russian thistle, Utah juniper

17. **Perennial plant reproductive capability:** All perennial plants should have the ability to reproduce sexually or asexually, except in drought years. Density of plants indicates that plants reproduce at level sufficient to fill available resource. Within capability of site there are no restrictions on seed or vegetative reproductive capacity.
-