

Ecological site R048AY415UT Mountain Loam (Oak)

Last updated: 3/01/2024
Accessed: 05/03/2024

General information

Provisional. A provisional ecological site description has undergone quality control and quality assurance review. It contains a working state and transition model and enough information to identify the ecological site.

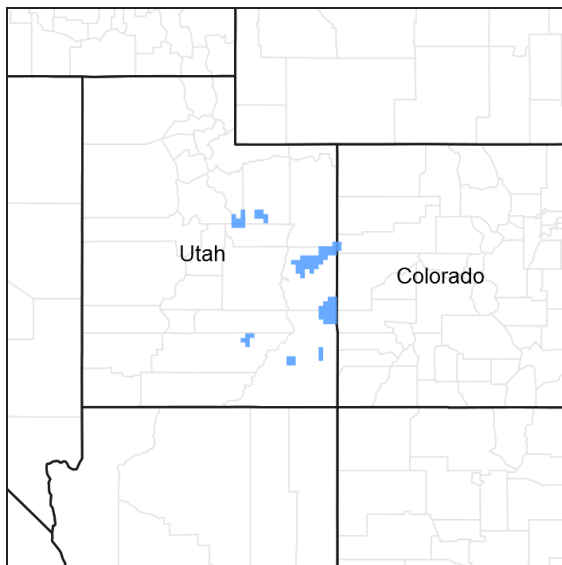

Figure 1. Mapped extent

Areas shown in blue indicate the maximum mapped extent of this ecological site. Other ecological sites likely occur within the highlighted areas. It is also possible for this ecological site to occur outside of highlighted areas if detailed soil survey has not been completed or recently updated.

MLRA notes

Major Land Resource Area (MLRA): 048A–Southern Rocky Mountains

MLRA 48A makes up about 45,920 square miles (119,000 square kilometers) and is the southern part of the Rocky Mountains. The Southern Rocky Mountains lies east of the Colorado Plateau, south of the Wyoming Basin, west of the Great Plains, and north of the Rio Grande Rift. It is in western and central Colorado, southeastern Wyoming, eastern Utah, and northern New Mexico. The headwaters of major rivers such as the Colorado, Yampa, Arkansas, Rio Grande, North Platte and South Plate rivers are located here. This MLRA has numerous national forests, including the Medicine Bow National Forest in Wyoming; the Routt, Arapaho, Roosevelt, Pike, San Isabel, White River, Gunnison, Grand Mesa, Uncompahgre, Rio Grande, and San Juan National Forests in Colorado; the Carson National Forest and part of the Santa Fe National Forest in New Mexico. Rocky Mountain National Park also is in this MLRA.

MLRA 48A is the southern Rocky Mountains physiographic region. The Southern Rocky Mountains consist primarily of two belts of strongly sloping to precipitous mountain ranges trending north to south. Several basins, or parks, are between the belts. Some high mesas and plateaus are included. It is characterized by mountain ranges that were uplifted during the Laramide Orogeny and then had periods of glaciation. The ranges include the Sangre de Cristo Mountains, the Laramie Mountains, and the Front Range in the east and the San Juan Mountains and the Sawatch and Park Ranges in the west. The ranges are dissected by many narrow stream valleys having steep gradients. In some areas the upper mountain slopes and broad crests are covered by snowfields and glaciers. Elevation typically

ranges from 6,500 to 14,400 feet (1,980 to 4,390 meters) in this area. The part of this MLRA in central Colorado includes the highest point in the Rockies, Mount Elbert, which reaches an elevation of 14,433 feet (4,400 meters). More than 50 peaks in the part of the MLRA in Colorado are at an elevation of more than 14,000 feet (4,270 meters). Many small glacial lakes are in the high mountains.

The mountains in this area were formed mainly by crustal uplifts during the late Cretaceous and early Tertiary periods. This large MLRA can be subdivided into at least 4 large general divisions. First is the Rockies on the east side of this area are called the "Front Range," which is a fault block that has been tilted up on edge and uplifted and is largely igneous and metamorphic geology. It was tilted up on the east edge, so there is a steep front on the east and the west side is more gently sloping and in the south east there are rocks exposed in the mountains are mostly Precambrian igneous and metamorphic rocks. Second is the tertiary rocks, primarily basalt and andesitic lava flows, tuffs, breccias, and conglomerates, are throughout this area (San Juan Mountains Area). The third division is Northwest part of the MLRA is dominantly sedimentary rock from the cretaceous/tertiary and Permian/Pennsylvanian periods. The fourth subset is the long and narrow Sangre de Cristos mountains uplifted in the Cenozoic are between the Rio Grande rift and the great plains. Many of the highest mountain ranges were reshaped by glaciation during the Pleistocene. Alluvial fans at the base of the mountains are recharge zones for local basin and valley fill aquifers. They also are important sources of sand and gravel.

The average annual precipitation ranges predominantly from 12 to 63 inches. Summer rainfall commonly occurs as high-intensity, convective thunderstorms. About half of the annual precipitation occurs as snow in winter; this proportion increases with elevation. In the mountains, deep snowpacks accumulate throughout the winter and generally persist into spring or early summer, depending on elevation. Some permanent snowfields and small glaciers are on the highest mountain peaks. In the valleys at the lower elevations, snowfall is lighter and snowpacks can be intermittent. The average annual temperature is 26 to 54 degrees F (-3 to 12 degrees C). The freeze-free period averages 135 days and ranges from 45 to 230 days, decreasing in length with elevation. The climate of this area is strongly dependent upon elevation; precipitation is greater, and temperatures are cooler at the higher elevations. The plant communities vary with elevation, aspect and change in latitudes due to changing in precipitation kind and timing and temperature.

The dominant soil orders in this MLRA are Mollisols, Alfisols, Inceptisols, and Entisols. The soils in the area dominantly have a frigid or cryic soil temperature regime and an ustic or udic soil moisture regime. Mineralogy is typically mixed, smectitic, or paramicaceous. In areas with granite, gneiss, and schist bedrock, Glossocryalfs (Seitz, Granile, and Leadville series) and Haplocryolls (Rogert series) formed in colluvium on mountain slopes. Dystrocryepts (Leighcan and Mummy series) formed on mountain slopes and summits at the higher elevations. In areas of andesite and rhyolite bedrock, Dystrocryepts (Endlich and Whitecross series) formed in colluvium on mountain slopes. In areas of sedimentary bedrock, Haplustolls (Towave series) formed on mountain slopes at low elevations and with low precipitation. Haplocryolls (Lamphier and Razorba series), Argicryolls (Cochetopa series), and Haplocryalfs (Needleton series) formed in colluvium on mountain slopes at high elevations.

Ecological site concept

The soils of this site formed mostly in alluvium derived from sandstone and shale and/or colluvium derived from sandstone and shale. Surface soils are cobbly loam, stony loam to loam in texture. Rock fragments may be present on the soil surface and throughout the profile, but generally make up less than 35 percent of the soil volume. These soils are moderately deep to deep, well-drained, and have slow to moderately rapid permeability. pH is neutral to moderately alkaline. Available water-holding capacity ranges from 2 to 7 inches of water in the upper 60 inches of soil. The soil moisture regime is mostly ustic and the soil temperature regime is frigid. Precipitation ranges from 16 to 22 inches annually.

Associated sites

R048AY436UT	Mountain Shallow Loam (Mountain Big Sagebrush) These sites often occur adjacent to each other.
-------------	--

Similar sites

R048AY430UT	Mountain Shallow Loam (Oak) These sites have very similar vegetation, however this sites has shallower soils.
-------------	---

Table 1. Dominant plant species

Tree	Not specified
Shrub	(1) <i>Quercus gambelii</i> (2) <i>Symphoricarpos oreophilus</i>
Herbaceous	(1) <i>Leymus salinus ssp. salinus</i> (2) <i>Poa fendleriana</i>

Physiographic features

This site occurs at elevations between 6,500 and 9,000 feet. It is found on mountain slopes with slopes ranging from 3 to 50 percent. Flooding and ponding do not occur on this site.

Table 2. Representative physiographic features

Landforms	(1) Mountain slope
Runoff class	Low to very high
Flooding frequency	None
Ponding frequency	None
Elevation	1,981–3,048 m
Slope	3–50%
Aspect	Aspect is not a significant factor

Climatic features

Average annual precipitation is 16 to 22 inches. Approximately 55 percent occurs as rain from May through October. On the average, November through June are the driest months and July through October are the wettest months. Cool temperatures and length of growing season are important environmental factors in this site. In average years, plants begin growth April 20 and end growth September 30.

Table 3. Representative climatic features

Frost-free period (characteristic range)	
Freeze-free period (characteristic range)	70-100 days
Precipitation total (characteristic range)	406-559 mm

Influencing water features

Due to its landscape position, this site is not influenced by streams or wetlands.

Soil features

The soils of this site formed mostly in alluvium derived from sandstone and shale and/or colluvium derived from sandstone and shale. Surface soils are cobbly loam, stony loam to loam in texture. Rock fragments may be present on the soil surface and throughout the profile, but generally make up less than 35 percent of the soil volume. These soils are moderately deep to deep, well-drained, and have slow to moderately rapid permeability. pH is neutral to moderately alkaline. Available water-holding capacity ranges from 2 to 7 inches of water in the upper 60 inches of soil. The soil moisture regime is mostly ustic and the soil temperature regime is frigid. Precipitation ranges from 16-22 inches annually.

Table 4. Representative soil features

Parent material	(1) Alluvium–sandstone and shale (2) Colluvium–sandstone and shale
Surface texture	(1) Cobbly, stony loam (2) Loam
Family particle size	(1) Fine-loamy
Drainage class	Well drained
Permeability class	Slow to moderate
Depth to restrictive layer	51–152 cm
Soil depth	51–152 cm
Surface fragment cover <=3"	0–20%
Surface fragment cover >3"	0–25%
Available water capacity (Depth not specified)	5.08–17.78 cm
Calcium carbonate equivalent (Depth not specified)	0–1%
Electrical conductivity (Depth not specified)	0–2 mmhos/cm
Sodium adsorption ratio (Depth not specified)	0
Soil reaction (1:1 water) (Depth not specified)	6.6–8.4
Subsurface fragment volume <=3" (Depth not specified)	0–25%
Subsurface fragment volume >3" (Depth not specified)	0–30%

Ecological dynamics

Reference State (State 1)

The reference state for the mountain loam (oak) site was determined by study of relic areas that have been protected from altered disturbance regimes and are considered to be representative of the historic climax plant community. Literature reviews, trends in plant community dynamics, and historical accounts are also considered.

State 1, the reference state, represents the historic plant communities of the mountain loam (oak) site and the naturally occurring dynamics associated with those communities. This state includes all known biotic communities that would exist under natural disturbance regimes and current climatic conditions. The dominant overstory species is Gambel oak (*Quercus gambelii*) with the understory dominated by the perennial bunchgrasses Salina Wildrye (*Leymus salinus* ssp. *salinus*), muttongrass (*Poa fendleriana*) and/or Bluebunch wheatgrass (*Elymus spicata*). The plant communities in state 1 are naturally resistant to disturbance and resilient following disturbance due to favorable amounts of precipitation and the ability of Gambel oak to resprout following disturbance. Wildfire is the predominant disturbance affecting ecological processes and is the primary factor driving plant community change in this state. The common fire return interval is 35-100 years and plant recovery following a wildfire is rapid, often with Gambel oak resprouting within the same growing season.

Community Phase 1.1 Gambel oak / Perennial Bunchgrasses

This plant community consists of mature Gambel oak trees that dominate the overstory and Salina Wildrye (*Leymus salinus* ssp. *salinus*), muttongrass (*Poa fendleriana*) and/or Bluebunch wheatgrass (*Elymus spicata*) that dominate the understory. Mountain brome, Geyer sedge, as well as other cool season grasses may be present. Common shrubs and forbs are mountain snowberry, Utah serviceberry, yarrow, and a suite of other species adapted to grow

either in the interspaces or under the canopy of Gambel oak stands. Bare ground is not common and no non-native plants are present.

Community Pathway 1.1a Wildfire --This pathway often occurs late in the growing season when precipitation is low and fuel load is at its peak. Gambel oak is at peak underground carbohydrate storage around this time of year, which provides the energy needed for resprouting.

Community Pathway 1.1b No Fire --This pathway is a subsequent step in natural succession that occurs when fire free periods approach their upper limits and allow fire sensitive species to encroach into Gambel oak sites.

Community Phase 1.2 Post-fire Community / Resprouting Gambel oak Thicket

This plant community consists of young Gambel oak shoots that are beginning to reestablish following a wildfire. Burned trunks will usually be visible above the new growth. The Gambel oak suckers often form dense thickets of foliage up to several feet in height which effectively intercept sunlight and crowd out potential invaders. Given adequate recovery time of a few months to a year, the interspaces will exhibit native buchgrasses and forbs, but few shrubs.

Community Pathway 1.2a Natural Succession—As the post-fire community ages, Gambel oak becomes less dominant near the soil surface, but maintains its dominance in the canopy. Perennial grasses become more robust and the plant community becomes more diverse with the establishment of shrubs and shade sensitive species.

Community Phase 1.3 Encroachment by Other Tree Species

This plant community is comparable in composition to community 1.1 with the addition of fire sensitive tree species such as Rocky mountain Douglas fir, Canyon maple, and/or white fir. The percent composition of these tree species is relatively low (3-5%).

Community Pathway 1.3a Wildfire-- This pathway often occurs late in the growing season when precipitation is low and fuel load is at its peak. Gambel oak also is at peak carbohydrate storage around this time of year, an adaptation which provides the energy needed to resprout and maintain its niche.

Transition 1-- Invasive Plants Transition from Reference State (State 1) to current Potential State (State 2)

This transition occurs when non-native or invasive species become established in the plant community. Common invasive species include Dalmation toadflax, Annual forbs, Dandelion, Houndstongue, Rubber rabbitbrush, Broom snakeweed, and Cheatgrass. Intermediate wheatgrass, Smooth brome, and Kentucky bluegrass may also spread into the site. Events that may facilitate the establishment of non-native plants are wildfire, introduction of livestock, seeding, and recreation.

Current Potential State (State 2)

State 2 is very similar to State 1 in form and function, with the exception of the presence of non-native plants and animals, possible extinctions of native species, and a different climate. State 2 is a description of the ecological site shortly following Euro-American settlement.

Community Phase 2.1 Gambel oak / Salina Wildrye

Phase 2.1 is 30-40% grasses, 5-15% forbs and 50-60% shrubs by air-dry weight. After a fire, Gambel oak sprouts vigorously and suppresses perennial grass and forb production. Non-native species are present, but not dominant.

Community Pathway 2.1a Wildfire -- This pathway often occurs late in the growing season when precipitation is low and fuel load is at its peak. Gambel oak is at peak underground carbohydrate storage around this time of year, which provides the energy needed for resprouting.

Community Pathway 2.1b No Fire -- This pathway is a subsequent step in natural succession that occurs when fire free periods approach their upper limits and allow fire sensitive species to encroach into Gambel oak sites.

Community Pathway 2.1c Prescribed Fire and Re-seed – This pathway occurs when land owners and/or land managers are attempting to improve the vigor of the native plant community.

Community Pathway 2.1d Continuous Heavy Grazing – This pathway occurs when improper grazing continues for extended periods of time not allowing for native plants to recover, ultimately lowering the health and vigor of these

plants to compete with available resources.

Community Phase 2.2 Resprouting Gambel oak thicket

Phase 2.2 Gambel oak stem density is less than phase 1.1, though oak production may be higher. Non-native species are present, but not dominant.

Community Pathway 2.2a Natural Succession on the site

Community Phase 2.3 Encroachment by other tree species

Phase 2.3 is characterized by encroachment of conifer species including Douglas fir, juniper and pinyon. Higher elevations of this ecological site are more susceptible to conifer encroachment. At lower elevations, this phase is characterized by decadent Gambel oak with patches of young sprouts. Gambel oak dies naturally around 80 years of age and promptly responds with vigorous young sprouts to replace the oak foliage. Native species are present, but not dominant

Community Pathway 2.3a Wildfire -- This pathway often occurs late in the growing season when precipitation is low and fuel load is at its peak. Gambel oak is at peak underground carbohydrate storage around this time of year, which provides the energy needed for resprouting.

Community Pathway 2.3b Brush Management (Fire) and re-seeding – Utilization of techniques such as prescribed fire and range seeding can reduce composition of invading conifers as well as temporarily reduce competition from oak to allow for the herbaceous component to become established.

Community Pathway 2.3c Continuous Heavy Grazing -- This pathway occurs when improper grazing continues for extended periods of time not allowing for native herbaceous plants and shrubs to recover, ultimately lowering the health and vigor of these plants to compete with available resources.

Community Phase 2.4 Seeded Gambel oak Woodland

Phase 2.4 is an aerial seeding following fire. Both native and non-native perennial grasses and forbs are included in most seed mixes. Under proper grazing, native grass and forb species can outcompete introduced species and dominate the understory within 5-10 years.

Community Pathway 2.4a Wildfire -- This pathway often occurs late in the growing season when precipitation is low and fuel load is at its peak. Gambel oak is at peak underground carbohydrate storage around this time of year, which provides the energy needed for resprouting.

Community Pathway 2.4b Natural Succession/prescribed grazing – This pathway can occur through natural succession and prescribed grazing. Over time the oak will begin to be the dominant aspect on the site, and with proper grazing management the herbaceous understory and shrubs will maintain health and vigor on the site.

Community Pathway 2.4c Continuous Heavy Grazing -- This pathway occurs when improper grazing continues for extended periods of time not allowing for native herbaceous plants and shrubs to recover, ultimately lowering the health and vigor of these plants to compete with available resources.

Community Phase 2.5 Overgrazed Gambel oak

Phase 2.5 displays a reduction in the herbaceous understory and/or shrub component do to improper grazing/browsing from livestock and/or wildlife.

Community Pathway 2.5a No Fire – lack of fire over time will allow other tree species to naturally encroach into the site.

Community Pathway 2.5b Brush Management (Mechanical) and re-seeding -- utilization of techniques such as mechanical brush management and range seeding can reduce composition of oak to allow for the herbaceous component to become established.

Community Pathway 2.5c Natural succession and prescribed grazing – practicing prescribed grazing over time will allow the herbaceous and shrub components to become established on this site.

Transition 2 Noxious Weed Invasion / Repeated Wildfires
Transition from State 2 to State 3

Transition 3 Prescribed Grazing (Goats)
Transition from State 2 to State 4

State 3 Noxious Weed State

State 3 is characterized by a dominance of non-native noxious weeds. The threshold has been crossed into State 3 and the dynamics of this site will likely prohibit the return back into State 2 without an extraordinary amount of external inputs.

Community Phase 3.1 Broadleaf weed dominates interspaces

Native herbaceous and/or shrubs have largely been replaced by prolific noxious weeds establishment which generally flourish in sites where there is a short fire return interval. This process makes it incredibly hard for native herbaceous species to become reestablished on the site. Gambel oak is able to remain on this site by utilizing available resources due to its extensive root system and its sprouting abilities following wildfire.

Community Pathway 3.1a Wildfire – The nature of this site with the abundance of noxious weeds/fine fuels shortens the fire return interval compared to the historic fire regime.

Community Phase 3.2 Weed co-dominant with resprouting Gambel oak

Following a wildfire, the herbaceous weed component and sprouting Gambel oak will dominate this site.

Community Pathway 3.2a Natural Succession – Due to the nature of this site, there is often a frequent fire return interval which will return this site back to Community Phase 3.1.

State 4: Herbaceous State:

Utilizing browsing animals such as goats, the threshold from State 2 is crossed into this State. Browsing animals will shift the competitive advantage to the herbaceous component leaving the site devoid of Gambel oak and dominated by the herbaceous understory.

Community Phase 4.1 Devoid of Gambel oak

State and transition model

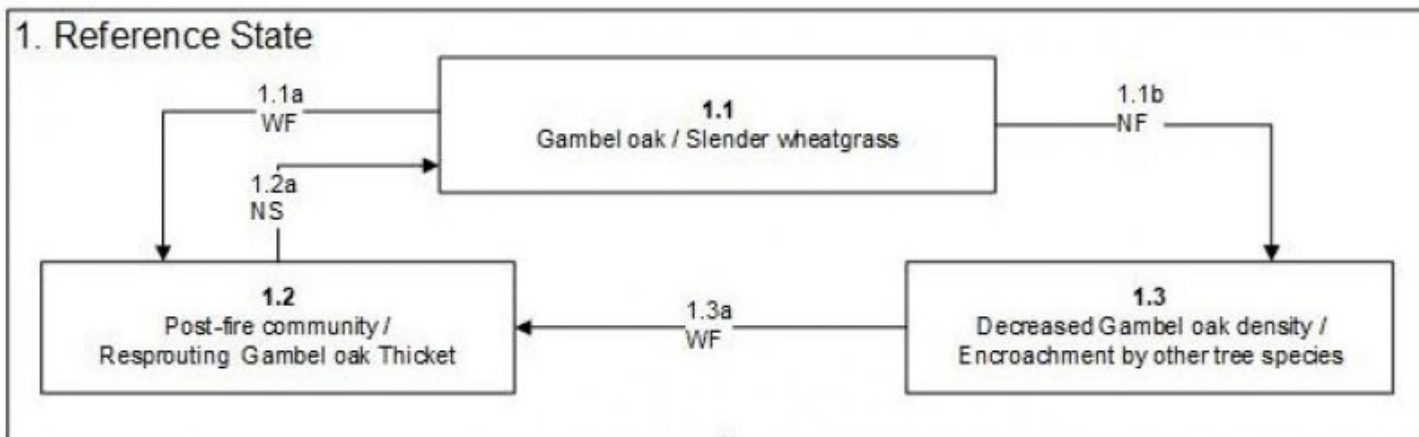

T1
IP

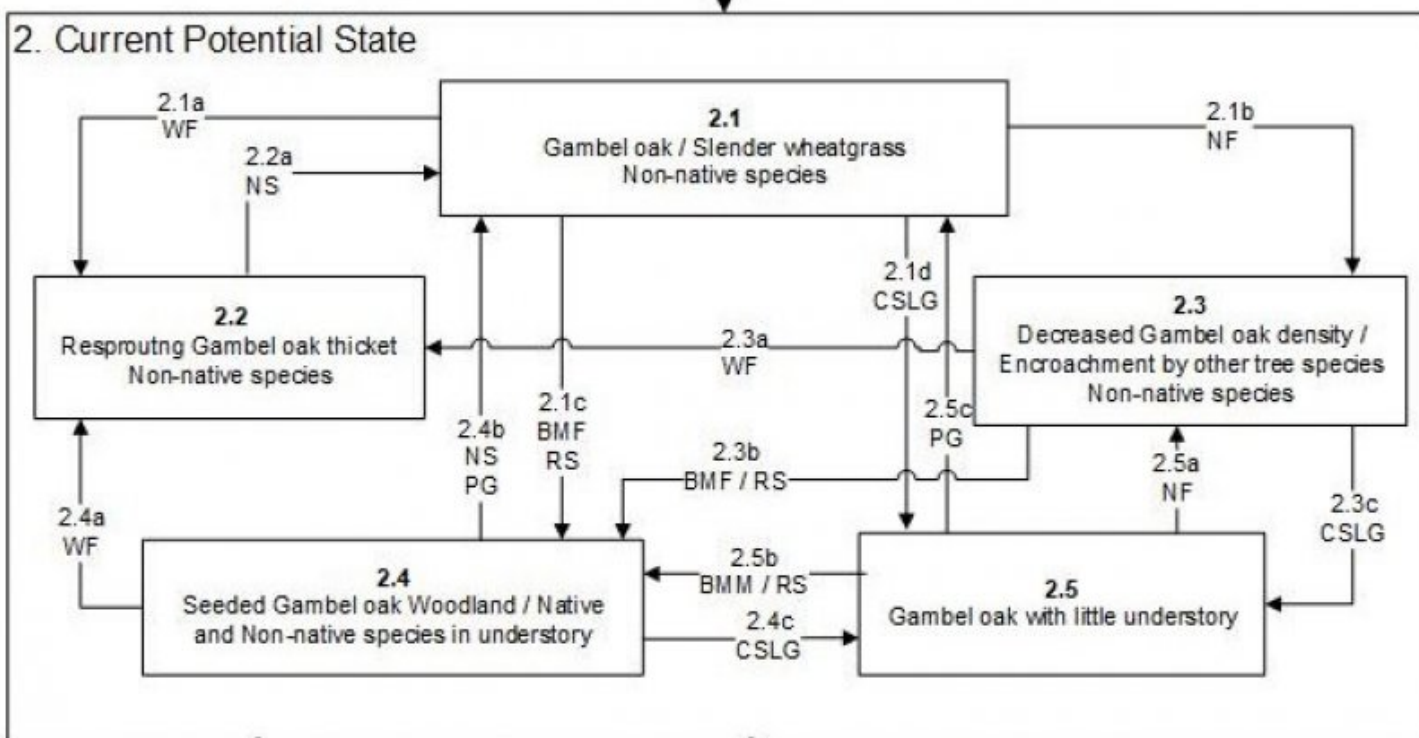

T2
NWI / RWF

T3
PG (Goats)

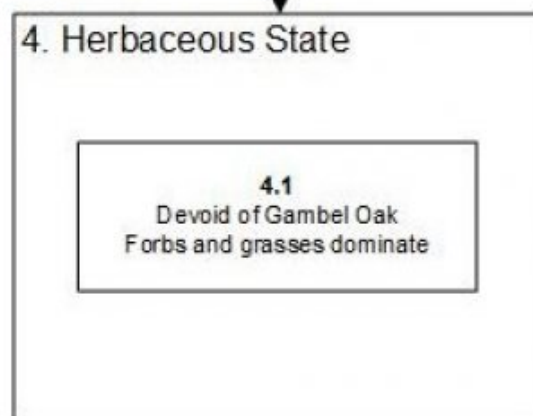
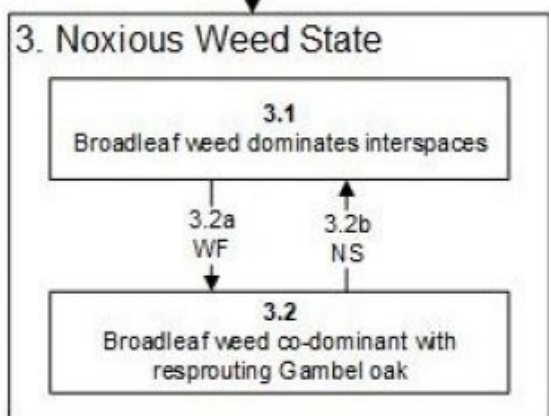

Legend: WF = Wildfire NF = No Fire BMM = Brush Management (Mechanical)
 RS = Re-seeding NS = Natural Succession BMF = Brush Management (Fire)
 PG = Prescribed Grazing RWF = Recurring Wildfire CSLG = Continuous Season-long Grazing
 RPT = Replant Trees IP = Introduced Species NWI = Noxious Weed Invasion

State 1
Reference State

Community 1.1
Reference Plant Community

The dominant aspect of this site is Gambel oak and serviceberry. The composition by air-dry weight is 35 percent perennial grasses, 10 percent forbs, and 55 percent shrubs.

Table 5. Annual production by plant type

Plant Type	Low (Kg/Hectare)	Representative Value (Kg/Hectare)	High (Kg/Hectare)
Shrub/Vine	370	708	1048
Grass/Grasslike	235	452	667
Forb	67	129	191
Total	672	1289	1906

Table 6. Ground cover

Tree foliar cover	0%
Shrub/vine/liana foliar cover	39-41%
Grass/grasslike foliar cover	19-21%
Forb foliar cover	9-11%
Non-vascular plants	0%
Biological crusts	0%
Litter	0%
Surface fragments >0.25" and <=3"	0%
Surface fragments >3"	0%
Bedrock	0%
Water	0%
Bare ground	0%

Table 7. Canopy structure (% cover)

Height Above Ground (M)	Tree	Shrub/Vine	Grass/ Grasslike	Forb
<0.15	-	-	-	-
>0.15 <= 0.3	-	-	-	9-11%
>0.3 <= 0.6	-	-	19-21%	-
>0.6 <= 1.4	-	-	-	-
>1.4 <= 4	-	39-41%	-	-
>4 <= 12	-	-	-	-
>12 <= 24	-	-	-	-
>24 <= 37	-	-	-	-
>37	-	-	-	-

Additional community tables

Table 8. Community 1.1 plant community composition

--	--	--	--	--

Group	Common Name	Symbol	Scientific Name	Annual Production (Kg/Hectare)	Foliar Cover (%)
Shrub/Vine					
0	Dominant Shrubs			482–740	
	Gambel oak	QUGA	<i>Quercus gambelii</i>	336–471	–
	mountain snowberry	SYOR2	<i>Symphoricarpos oreophilus</i>	67–135	–
	Utah serviceberry	AMUT	<i>Amelanchier utahensis</i>	40–67	–
	alderleaf mountain mahogany	CEMO2	<i>Cercocarpus montanus</i>	40–67	–
3	Sub-Dominant Shrubs			202–538	
	Shrub (>.5m)	2SHRUB	<i>Shrub (>.5m)</i>	67–135	–
	mountain big sagebrush	ARTRV	<i>Artemisia tridentata ssp. vaseyana</i>	13–40	–
	longleaf brickellbush	BRLO	<i>Brickellia longifolia</i>	13–40	–
	curl-leaf mountain mahogany	CELE3	<i>Cercocarpus ledifolius</i>	13–40	–
	yellow rabbitbrush	CHV18	<i>Chrysothamnus viscidiflorus</i>	13–40	–
	rubber rabbitbrush	ERNA10	<i>Ericameria nauseosa</i>	13–40	–
	Oregon boxleaf	PAMY	<i>Paxistima myrsinites</i>	13–40	–
	wild crab apple	PERA4	<i>Peraphyllum ramosissimum</i>	13–40	–
	chokecherry	PRVI	<i>Prunus virginiana</i>	13–40	–
	antelope bitterbrush	PUTR2	<i>Purshia tridentata</i>	13–40	–
	Woods' rose	ROWO	<i>Rosa woodsii</i>	13–40	–
Grass/Grasslike					
0	Dominant Grasses			269–471	
	saline wildrye	LESAS	<i>Leymus salinus ssp. salinus</i>	135–202	–
	muttongrass	POFE	<i>Poa fendleriana</i>	67–135	–
	bluebunch wheatgrass	PSSP6	<i>Pseudoroegneria spicata</i>	67–135	–
1	Sub-Dominant Grasses			135–280	
	Grass, annual	2GA	<i>Grass, annual</i>	40–67	–
	Grass, perennial	2GP	<i>Grass, perennial</i>	40–67	–
	Letterman's needlegrass	ACLE9	<i>Achnatherum lettermanii</i>	13–40	–
	Columbia needlegrass	ACNE9	<i>Achnatherum nelsonii</i>	13–40	–
	mountain brome	BRMA4	<i>Bromus marginatus</i>	13–40	–
	Ross' sedge	CARO5	<i>Carex rossii</i>	13–40	–
	squirreltail	ELEL5	<i>Elymus elymoides</i>	13–40	–
	slender wheatgrass	ELTR7	<i>Elymus trachycaulus</i>	13–40	–
	needle and thread	HECO26	<i>Hesperostipa comata</i>	13–40	–
	spike fescue	LEK12	<i>Leucopoa kingii</i>	13–40	–
	western wheatgrass	PASM	<i>Pascopyrum smithii</i>	13–40	–
Forb					
2	Sub-Dominant Forbs			202–269	
	Forb, annual	2FA	<i>Forb, annual</i>	202–269	–
	Forb, perennial	2FP	<i>Forb, perennial</i>	202–269	–
	common yarrow	ACMI2	<i>Achillea millefolium</i>	13–27	–
	white sagebrush	ARLU	<i>Artemisia ludoviciana</i>	13–27	–

Wyoming Indian paintbrush	CALI4	<i>Castilleja linariifolia</i>	13–27	–
Brenda's yellow cryptantha	CRFL5	<i>Cryptantha flava</i>	13–27	–
twolobe larkspur	DENU2	<i>Delphinium nuttallianum</i>	13–27	–
Shockley's buckwheat	ERSH	<i>Eriogonum shockleyi</i>	13–27	–
pineywoods geranium	GECA3	<i>Geranium caespitosum</i>	13–27	–
Nevada pea	LALA3	<i>Lathyrus lanszwertii</i>	13–27	–
tailcup lupine	LUCAC3	<i>Lupinus caudatus ssp. caudatus</i>	13–27	–
creeping barberry	MARE11	<i>Mahonia repens</i>	13–27	–
dusty beardtongue	PECO5	<i>Penstemon comarrhenus</i>	13–27	–
Mt. Albert goldenrod	SOSI3	<i>Solidago simplex</i>	13–27	–
Pacific aster	SYHC	<i>Symphotrichum chilense var. chilense</i>	13–27	–
American vetch	VIAM	<i>Vicia americana</i>	13–27	–

Animal community

This site provides proper grazing for cattle and sheep during spring, summer, and fall.

This site produces food and cover for wildlife. Wildlife using this site include jackrabbit, coyote, mule deer, and elk.

Hydrological functions

The soil is in hydrologic groups B and C. The runoff curve numbers are 61 through 86 depending on the condition of the watershed.

Recreational uses

This site has aesthetic appeal and many recreation opportunities.

Wood products

None

Inventory data references

Type Location: See the appropriate soil survey report

Contributors

George Cook , David Somerville

Approval

Kirt Walstad, 3/01/2024

Rangeland health reference sheet

Interpreting Indicators of Rangeland Health is a qualitative assessment protocol used to determine ecosystem condition based on benchmark characteristics described in the Reference Sheet. A suite of 17 (or more) indicators are typically considered in an assessment. The ecological site(s) representative of an assessment location must be known prior to applying the protocol and must be verified based on soils and climate. Current plant community cannot be used to identify the ecological site.

Author(s)/participant(s)	
Contact for lead author	
Date	03/12/2020
Approved by	Kirt Walstad
Approval date	
Composition (Indicators 10 and 12) based on	Annual Production

Indicators

1. **Number and extent of rills:** No rills present. Very minor rill development may occur in sparsely vegetated areas. If rills are present, they should be widely spaced and not connected. Rill development may increase following large storm events, but should begin to heal during the following growing season. Frost heaving will accelerate recovery. Rill development may increase when run inflow enters site from adjacent sites that produce large amounts of runoff (i.e. steeper sites, slickrock, rock outcrop). Site is essentially level and rills do not form.

2. **Presence of water flow patterns:** Water flow patterns will be very short (1-3'), narrow (<1'), and meandering; interrupted by plants and exposed rocks. Slight to no evidence of erosion or deposition associated with flow patterns. Where slopes exceed 5%, water flow patterns may be of medium length (5 –10 feet).

3. **Number and height of erosional pedestals or terracettes:** Plants may have small pedestals (1-3") where they are adjacent to water flow patterns, but without exposed roots. Terracettes should be few and stable. Terracettes should be small (1-3") and show little sign of active erosion. Some plants may appear to have a pedestal but rather than be formed by erosion, they are the result of litter and soil accumulating at plant bases, forming the appearance of a pedestal.

4. **Bare ground from Ecological Site Description or other studies (rock, litter, lichen, moss, plant canopy are not bare ground):** 15-30% bare ground (soil with no protection from raindrop impact). Very few if any bare spaces of greater than 1 square foot. In general, bare ground increases as production decreases. As species composition of shrubs relative to grasses increases, bare ground is likely to increase. Poorly developed biological soil crust that is susceptible to erosion from raindrop impact should be recorded as bare ground.

5. **Number of gullies and erosion associated with gullies:** No gullies present.

6. **Extent of wind scoured, blowouts and/or depositional areas:** Very minor evidence of active wind-generated soil movement. Wind scoured (blowouts) and depositional areas are rarely present. If present they have muted features and are mostly stabilized with vegetation and/or biological crust.

7. **Amount of litter movement (describe size and distance expected to travel):** Most litter resides in place with some redistribution caused by water and wind movement. Very minor litter removal may occur in water flow paths with deposition occurring at points of obstruction. Where litter movement does occur, litter accumulates at plant bases. Some leaves, stems, and small twigs may accumulate in soil depressions adjacent to plants. Woody stems are not likely to move.

-
8. **Soil surface (top few mm) resistance to erosion (stability values are averages - most sites will show a range of values):** This site should have an erosion rating of 5 to 6 under plant canopies and a rating of 4 to 5 in the interspaces with an average rating of 5 using the soil stability kit test.
-
9. **Soil surface structure and SOM content (include type of structure and A-horizon color and thickness):** A--0 to 2E cm; brown (10YR 4/3) extremely stony fine sandy loam, dark brown (10YR 3/3) moist; weak fine granular structure; soft, friable, slightly sticky and slightly plastic; few coarse and medium and common fine and very fine roots; few very fine pores; 25 percent stones, 25 percent cobbles and 15 percent gravel; noneffervescent; moderately alkaline (pH 7.9); clear smooth boundary. (18 to 30 cm thick)
-
10. **Effect of community phase composition (relative proportion of different functional groups) and spatial distribution on infiltration and runoff:** Bunchgrasses and shrubs are more important than trees for enhancing infiltration and preventing runoff. Although tree canopies intercept rainfall and provide a barrier to raindrop impact, some evergreen trees such as pinyon and juniper may intercept so much rainfall that not enough water reaches the ground to supply the understory. In this situation, the soil beneath tree canopies is often unvegetated and susceptible to erosion. Bunchgrasses and shrubs, on the other hand, not only intercept rainfall, but contribute litter cover, soil organic matter, and physical stability to the soil. Bunchgrasses contribute organic matter directly to soil through root decay, and organic matter helps stabilize soil aggregates and maintain soil porosity. Shrubs hold snow and slow wind evaporation. Bunchgrass bases intercept litter and soil in water flow paths, reducing runoff. Biological soil crusts (where present) are resistant to raindrop impact and splash erosion. Spatial distribution of vascular plants and well-developed biological soil crusts (where present) provides detention storage and surface roughness that slows runoff, allowing time for infiltration. Water flow patterns are likely to develop under tree canopies, where herbaceous vegetation is sparse.
-
11. **Presence and thickness of compaction layer (usually none; describe soil profile features which may be mistaken for compaction on this site):** A compaction layer is not expected.
-
12. **Functional/Structural Groups (list in order of descending dominance by above-ground annual-production or live foliar cover using symbols: >>, >, = to indicate much greater than, greater than, and equal to):**
- Dominant: Dominant: Sprouting shrubs (Gambel oak, mountain snowberry) > perennial cool-season bunchgrasses (saline wildrye, muttongrass, bluebunch wheatgrass)
- Sub-dominant:
- Other: Other: Perennial forbs > other shrubs > other perennial grasses
- Additional:
-
13. **Amount of plant mortality and decadence (include which functional groups are expected to show mortality or decadence):** During years with average to above average precipitation, there should be very little recent mortality or decadence apparent in either the shrubs or grasses. Some mortality of bunchgrass and other shrubs may occur during very severe (long-term) droughts. There may be partial mortality of individual bunchgrasses and shrubs during less severe drought and toward the end of the fire cycle. Long-lived species dominate the site. Open spaces from disturbance are quickly filled by new plants through seedlings and asexual reproduction (tillering).

14. **Average percent litter cover (%) and depth (in):** Litter cover includes litter under plants. Most litter will be fine (herbaceous) litter. Litter will be concentrated under plant canopies and sparser between plant canopies, with an average cover of 25-35% and an average depth of 0.5-1 inches. Litter cover may increase following years with favorable growing conditions. Excess litter may accumulate in absence of disturbance. Vegetative production may be reduced if litter cover exceeds 40%.

15. **Expected annual annual-production (this is TOTAL above-ground annual-production, not just forage annual-production):** 1150-1250 lbs/acre.
Even the most stable communities exhibit a range of production values. Production will vary between communities and across the MRLA. Refer to the community descriptions in the ESD. Production will differ across the MLRA due to the naturally occurring variability in weather, soils, and aspect. The biological processes on this site are complex; therefore, representative values are presented in a land management context.

16. **Potential invasive (including noxious) species (native and non-native). List species which BOTH characterize degraded states and have the potential to become a dominant or co-dominant species on the ecological site if their future establishment and growth is not actively controlled by management interventions. Species that become dominant for only one to several years (e.g., short-term response to drought or wildfire) are not invasive plants. Note that unlike other indicators, we are describing what is NOT expected in the reference state for the ecological site:** Invasive species unlikely because of high elevation

17. **Perennial plant reproductive capability:** All perennial plants should have the ability to reproduce sexually or asexually, except in drought years. Density of plants indicates that plants reproduce at level sufficient to fill available resource. Within capability of site there are no restrictions on seed or vegetative reproductive capacity.
