

Ecological site R049XA116WY

Igneous (Foothills and Mountains Southeast)

Accessed: 05/19/2024

General information

Provisional. A provisional ecological site description has undergone quality control and quality assurance review. It contains a working state and transition model and enough information to identify the ecological site.

Associated sites

R049XA160WY	Shallow Igneous (Foothills and Mountains Southeast) Shallow Igneous
-------------	---

Similar sites

R049XA160WY	Shallow Igneous (Foothills and Mountains Southeast) Shallow Igneous, 049XA160WY has higher production
-------------	---

Table 1. Dominant plant species

Tree	Not specified
Shrub	Not specified
Herbaceous	Not specified

Physiographic features

This site is found in an upland position on rolling to steep mountain slopes and ridges

Table 2. Representative physiographic features

Landforms	(1) Hill (2) Ridge (3) Escarpment
Flooding frequency	None
Ponding frequency	None
Elevation	1,981–2,591 m
Slope	5–70%
Ponding depth	0 cm
Aspect	Aspect is not a significant factor

Climatic features

Annual precipitation ranges from 15-19 inches per year. Wide fluctuations may occur in yearly precipitation and result in more dry years than those with more than normal precipitation. Temperatures show a wide range between summer and winter and between daily maximums and minimums. This is predominantly due to the high elevation and dry air, which permits rapid incoming and outgoing radiation. Cold air outbreaks in winter move rapidly from northwest to southeast and account for extreme minimum temperatures. Extreme storms may occur during the

winter, but most severely affect ranch operations during late winter and spring.

Prevailing winds are from the southwest and strong winds are less frequent than over other areas of Wyoming. Occasional storms, however, can bring brief periods of high winds with gusts exceeding 50 mph.

Growth of native cool season plants begins about May 1 and continues to about August 1.

The following information is from the “Hecla 1E” climate station:

Minimum Maximum 5 yrs. out of 10 between
 Frost-free period (days): 93 151 May 20 – September 14
 Freeze-free period (days): 106 184 May 9 – September 26
 Annual Precipitation (inches): 9.56 24.23

Mean annual precipitation: 16.04 inches
 Mean annual air temperature: 44.7F (32.1F Avg. Min. to 57.2F Avg. Max.)
 For detailed information visit the Natural Resources Conservation Service National Water and Climate Center at <http://www.wcc.nrcs.usda.gov/> website. Other climate station(s) representative of this precipitation zone include “Glenrock 14 SSE”, “Foxpark” and “Horse Creek 2 NW”.

Table 3. Representative climatic features

Frost-free period (average)	151 days
Freeze-free period (average)	184 days
Precipitation total (average)	483 mm

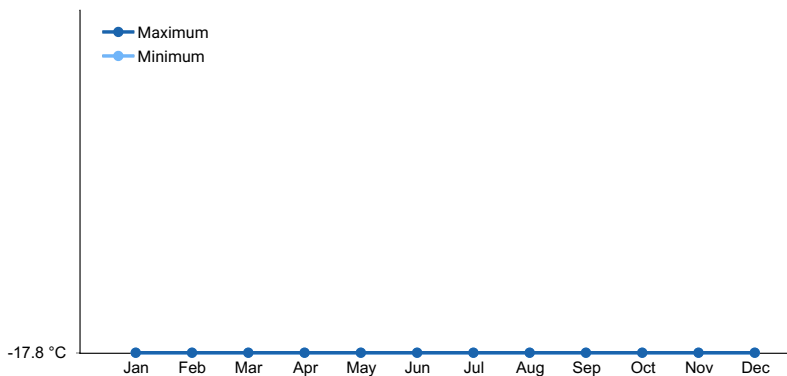

Figure 1. Monthly average minimum and maximum temperature

Influencing water features

Soil features

The soils of this site are very shallow (less than 10”to bedrock), well-drained to somewhat excessively drained, and formed in residuum. They are usually found on mountain sides.

Major Soil Series correlated to this site include:

Table 4. Representative soil features

Surface texture	(1) Cobbly sandy loam (2) Stony loamy sand (3) Bouldery
Family particle size	(1) Loamy

Drainage class	Well drained to somewhat excessively drained
Permeability class	Moderate to moderately rapid
Soil depth	10–25 cm
Surface fragment cover <=3"	10–25%
Surface fragment cover >3"	20–45%
Available water capacity (0-101.6cm)	0.64–1.27 cm
Calcium carbonate equivalent (0-101.6cm)	0%
Electrical conductivity (0-101.6cm)	0 mmhos/cm
Sodium adsorption ratio (0-101.6cm)	0
Soil reaction (1:1 water) (0-101.6cm)	5.6–7.2
Subsurface fragment volume <=3" (Depth not specified)	15–30%
Subsurface fragment volume >3" (Depth not specified)	30–45%

Ecological dynamics

As this site deteriorates because of a combination of frequent and severe grazing, species such as Sandberg bluegrass, threadleaf sedge, prairie junegrass unpalatable forbs and threetip sagebrush will increase. Grasses such as bluebunch wheatgrass, Montana wheatgrass, and Parry's oatgrass will decrease in frequency and production.

The Historic Climax Plant Community (description follows the plant community diagram) has been determined by study of rangeland relic areas, or areas protected from excessive disturbance. Trends in plant communities going from heavily grazed areas to lightly grazed areas, seasonal use pastures, and historical accounts have also been used.

The following is a State and Transition Model Diagram that illustrates the common plant communities (states) that can occur on the site and the transitions between these communities. The ecological processes will be discussed in more detail in the plant community narratives following the diagram.

State and transition model

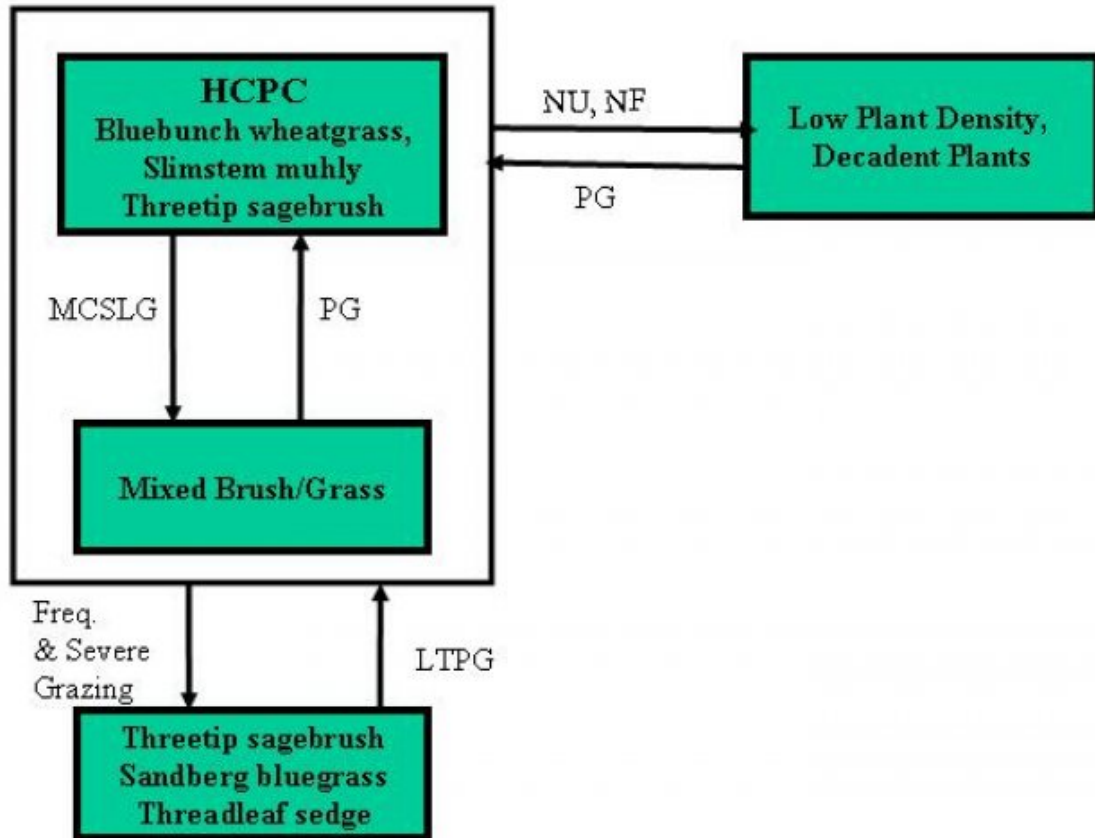

Freq. & Severe Grazing - Frequent and Severe Utilization of the Cool-season Mid-grasses during the Growing Season

LTPG - Long-term Prescribed Grazing

MCSLG - Moderate, Continuous Season-long Grazing

NU, NF - No Use and No Fire

PG - Prescribed Grazing (proper stocking rates with adequate recovery periods during the growing season)

Community 1.1

Bluebunch wheatgrass, Slimstem muhly, Threetip sagebrush Plant Community

This plant community is the interpretive plant community for this site and is considered to be the Historic Climax Plant Community (HCPC). This plant community evolved with grazing by large herbivores and is well suited for grazing by domestic livestock. This plant community can be found on areas that are properly managed with grazing, and sometimes on areas receiving occasional short periods of rest. The potential vegetation is about 65% grasses or grass-like plants, 15% forbs, and 25% woody plants. The major grasses include bluebunch wheatgrass, and slimstem muhly. Other grasses occurring on the state include threadleaf sedge, Sandberg bluegrass, Canby bluegrass and Parry's oatgrass. A variety of forbs also occur. Threetip sagebrush can be a conspicuous element of this state. Plant diversity is high. The total annual production (air-dry weight) of this state is about 550 lbs./acre, but it can range from about 350 lbs./acre in unfavorable years to about 700 lbs./acre in above average years. The following is the growth curve of this plant community expected during a normal year: Growth curve number: Growth curve name: Growth curve description: JAN FEB MAR APR MAY JUN JUL AUG SEP OCT NOV DEC 0 0 0 5 20 45 20 5 5 0 0 0 0 (Monthly percentages of total annual growth) This plant community is extremely stable and well adapted to the climatic conditions. The diversity in plant species allows for high drought tolerance. This is a sustainable plant community (site/soil stability, watershed function, and biologic integrity). Transitions or pathways leading to other plant communities are as follows: • No use and no fire for 20 years or more will convert this plant community to the Low Plant Density, Decadent Plants Community. • Moderate, continuous season-long grazing will convert the plant community to the Mixed Brush/Grass Plant Community.

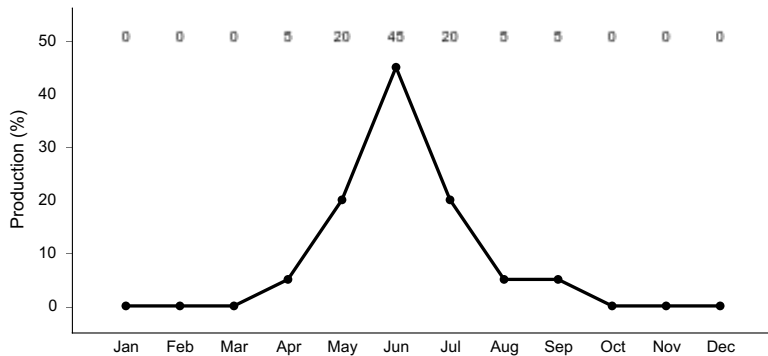

Figure 3. Plant community growth curve (percent production by month). WY1001, 15-19SE upland sites.

State 2

Mixed Brush/Grass Plant Community

Community 2.1

Mixed Brush/Grass Plant Community

Historically, this plant community evolved under grazing and a low fire frequency. Currently, it is found under moderate, season-long grazing by livestock. Cool-season grasses make up the majority of the understory with the balance made up of annual cool-season grasses, and miscellaneous forbs. Dominants include threadleaf sedge, western wheatgrass, and Sandberg bluegrass. Forbs commonly found in this plant community include Hoods phlox and western yarrow. When compared to the Historic Climax Plant Community, threetip sagebrush has increased but does not produce the thick canopy cover found on sites with moderately deep to deep soils. Production of cool-season grasses has been reduced. The mixture of sagebrush, grass and forbs provide a diverse plant community that will support domestic livestock and wildlife such as mule deer and antelope. The total annual production (air-dry weight) of this state is about 450 pounds per acre, but it can range from about 300 lbs./acre in unfavorable years to about 600 lbs./acre in above average years. The following is the growth curve of this plant community expected during a normal year: Growth curve number: Growth curve name: Growth curve description: JAN FEB MAR APR MAY JUN JUL AUG SEP OCT NOV DEC 0 0 0 5 20 45 20 5 5 0 0 0 (Monthly percentages of total annual growth) This plant community is resistant to change. The herbaceous species present are well adapted to grazing; however, species composition can be altered through long-term overgrazing. If the herbaceous component is intact, it tends to be resilient if the disturbance is not long-term. Transitions or pathways leading to other plant communities are as follows: • Prescribed grazing, will convert this plant community to the Bluebunch wheatgrass, Slimstem muhly, Threetip sagebrush Plant Community. The probability of this occurring is high. • Frequent and severe grazing, will

convert the plant community to the Threetip sagebrush, Sandberg bluegrass, Threadleaf sedge Plant Community. The probability of this occurring is high. If bare areas exist, along with no recovery periods from grazing, annuals can invade and plants not as resistant to grazing will be reduced.

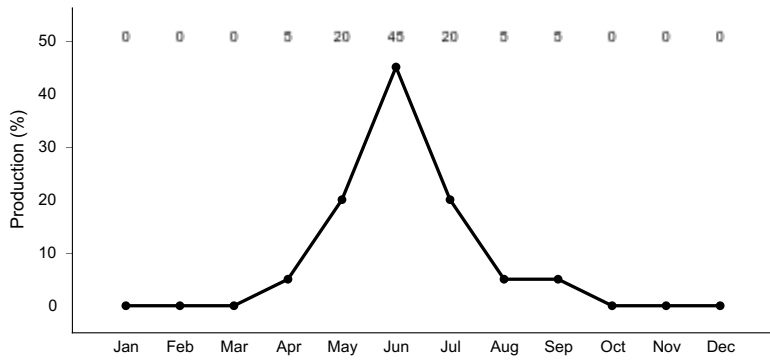

Figure 4. Plant community growth curve (percent production by month). WY1001, 15-19SE upland sites.

State 3 Low Plant Density, Decadent Plants Community

Community 3.1 Low Plant Density, Decadent Plants Community

This plant community is the result of long-term protection from grazing and fire. At first, excessive litter builds up shading out some of the grasses and forbs. Other plants become decadent with low vigor. Bunch grasses often develop dead centers. Eventually, the interspaces between plants increase in size leaving more soil surface exposed. Organic matter oxidizes in the air rather than being incorporated into the soil. The dominant plants tend to be somewhat similar to those found in the Historic Climax Plant Community. Weedy species and sedges have increased. Noxious weeds may invade the state if a seed source is present. Plant diversity is moderate to high. The total annual production (air-dry weight) of this state is about 500 pounds per acre, but it can range from about 350 lbs./acre in unfavorable years to about 650 lbs./acre in above average years. The following is the growth curve of the plant community expected during a normal year: Growth curve number: Growth curve name: Growth curve description: JAN FEB MAR APR MAY JUN JUL AUG SEP OCT NOV DEC 0 0 0 5 20 45 20 5 5 0 0 0 (Monthly percentages of total annual growth) This plant community is not resistant to change and is more vulnerable to severe disturbance than the HCPC. The introduction of grazing quickly changes the plant community. Soil erosion is accelerated because of increased bare ground. Water flow patterns and pedestaling are obvious. Infiltration is reduced and runoff is increased. Transitions or pathways leading to other plant communities are as follows: • Prescribed grazing, will return this plant community to at or near the Bluebunch wheatgrass, Slimstem muhly, Threetip sagebrush Plant Community.

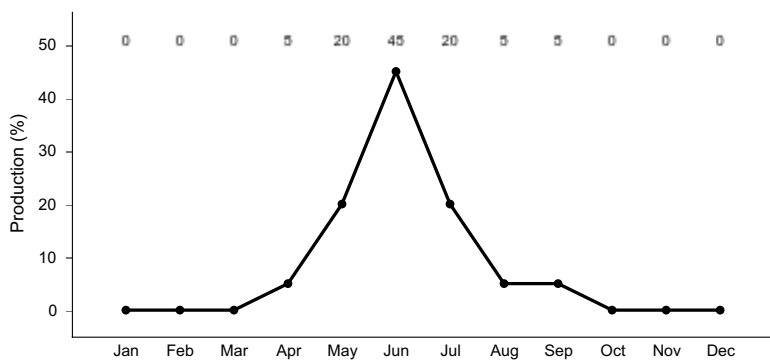

Figure 5. Plant community growth curve (percent production by month). WY1001, 15-19SE upland sites.

State 4 Threetip sagebrush, Sandberg bluegrass, Threadleaf sedge Plant Community

Community 4.1

Threetip sagebrush, Sandberg bluegrass, Threadleaf sedge Plant Community

This plant community is created when the Mixed Brush/Grass Plant Community is subjected to frequent and severe grazing. Threetip sagebrush, Sandberg bluegrass, herbaceous cinquefoils, hairy goldenaster, and threadleaf sedge will dominate the state. Compared to the HCPC, threetip sagebrush has increased. Virtually all cool-season mid-grasses are severely decreased. Plant diversity is low. The total annual production (air-dry weight) of this state is about 250 pounds per acre, but it can range from about 200 lbs./acre in unfavorable years to about 350 lbs./acre in above average years. The following is the growth curve of the plant community expected during a normal year:

Growth curve number: Growth curve name: Growth curve description: JAN FEB MAR APR MAY JUN JUL AUG SEP OCT NOV DEC 0 0 0 5 20 45 20 5 5 0 0 0 (Monthly percentages of total annual growth)

This plant community is relatively stable and somewhat resistant to overgrazing. The low growing grasses, sedges and threetip sagebrush effectively compete against the establishment of perennial cool-season grasses. The watershed is usually functioning. The biotic integrity is reduced by the lack of diversity in the plant community. Transitions or pathways leading to other plant communities are as follows:

- Prescribed grazing will eventually return this plant community to the Mixed Brush/Grass Plant Community.
- Long-term, prescribed grazing will eventually return this plant community to at or near the Bluebunch wheatgrass, Slimstem muhly, Threetip sagebrush Plant Community.

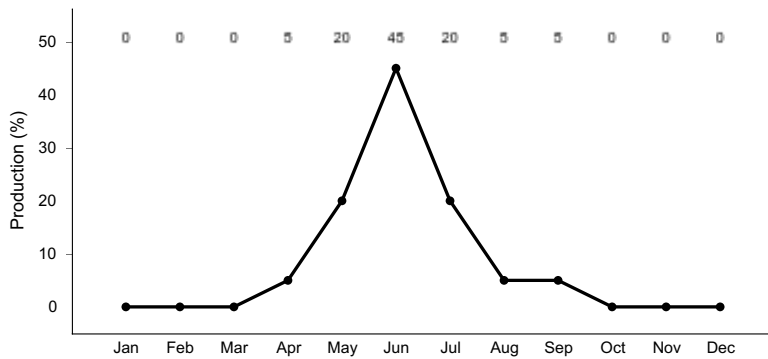

Figure 6. Plant community growth curve (percent production by month). WY1001, 15-19SE upland sites.

Additional community tables

Table 5. Community 1.1 plant community composition

Group	Common Name	Symbol	Scientific Name	Annual Production (Kg/Hectare)	Foliar Cover (%)
Grass/Grasslike					
1				155–308	
	bluebunch wheatgrass	PSSP6	<i>Pseudoroegneria spicata</i>	155–216	–
	slimstem muhly	MUFI	<i>Muhlenbergia filiculmis</i>	31–93	–
2				185–247	
	Grass, perennial	2GP	<i>Grass, perennial</i>	0–31	–
	Indian ricegrass	ACHY	<i>Achnatherum hymenoides</i>	0–31	–
	threadleaf sedge	CAFI	<i>Carex filifolia</i>	0–31	–
	Parry's oatgrass	DAPA2	<i>Danthonia parryi</i>	0–31	–
	Montana wheatgrass	ELAL7	<i>Elymus albicans</i>	0–31	–
	Idaho fescue	FEID	<i>Festuca idahoensis</i>	0–31	–
	needle and thread	HECO26	<i>Hesperostipa comata</i>	0–31	–
	prairie Junegrass	KOMA	<i>Koeleria macrantha</i>	0–31	–
	mountain muhly	MUMO	<i>Muhlenbergia montana</i>	0–31	–
	mat muhly	MURI	<i>Muhlenbergia richardsonis</i>	0–31	–
	western wheatgrass	PASM	<i>Pascopyrum smithii</i>	0–31	–
	muttongrass	POFE	<i>Poa fendleriana</i>	0–31	–
	Sandberg bluegrass	POSE	<i>Poa secunda</i>	0–31	–
Forb					
3				31–93	
	Forb, perennial	2FP	<i>Forb, perennial</i>	0–31	–
	yarrow	ACHIL	<i>Achillea</i>	0–31	–
	white sagebrush	ARLU	<i>Artemisia ludoviciana</i>	0–31	–
	milkvetch	ASTRA	<i>Astragalus</i>	0–31	–
	larkspur	DELPH	<i>Delphinium</i>	0–31	–
	buckwheat	ERIOG	<i>Eriogonum</i>	0–31	–
	hairy false goldenaster	HEVI4	<i>Heterotheca villosa</i>	0–31	–
	beardtongue	PENST	<i>Penstemon</i>	0–31	–
	spiny phlox	PHHO	<i>Phlox hoodii</i>	0–31	–
	cinquefoil	POTEN	<i>Potentilla</i>	0–31	–
Shrub/Vine					
4				7–62	
	threetip sagebrush	ARTR4	<i>Artemisia tripartita</i>	7–62	–
	threetip sagebrush	ARTR4	<i>Artemisia tripartita</i>	7–62	–
5				7–62	
	black sagebrush	ARNO4	<i>Artemisia nova</i>	7–62	–
6				0–31	
	yellow rabbitbrush	CHVI8	<i>Chrysothamnus viscidiflorus</i>	0–31	–
7				0–31	
	rubber rabbitbrush	ERNA10	<i>Ericameria nauseosa</i>	0–31	–
8				0–31	
	winterfat	KRLA2	<i>Krascheninnikovia lanata</i>	0–31	–

Animal community

Animal Community – Wildlife Interpretations

Bluebunch wheatgrass, Slimstem muhly, Threetip sagebrush Plant Community (HCPC): The predominance of grasses in this plant community favors grazers and mixed-feeders, such as bison and elk. Suitable thermal and escape cover for deer may be limited due to the low quantities of woody plants. However, topographical variations could provide some escape cover. Birds that would frequent this plant community include Western meadowlarks, horned larks, and golden eagles. Many grassland obligate small mammals would occur here.

Mixed Brush/Grass Plant Community: The combination of an overstory of sagebrush and an understory of grasses and forbs provide a very diverse plant community for wildlife. The crowns of sagebrush tend to break up hard crusted snow on winter ranges, so mule deer may use this state for foraging and cover year-round, as would cottontail and jack rabbits.

Low Plant Density, Decadent Plants Community: This plant community can provide important winter foraging for elk and mule deer, as sagebrush can approach 15% protein and 40-60% digestibility during that time.

Threetip sagebrush, Sandberg bluegrass, Threadleaf sedge Plant Community: This plant community may be useful for the same large grazers that would use the Historic Climax Plant Community. However, the plant community composition is less diverse, and thus, less apt to meet the seasonal needs of these animals.

Animal Community – Grazing Interpretations

The following table lists suggested stocking rates for cattle under continuous season-long grazing under normal growing conditions. These are conservative estimates that should be used only as guidelines in the initial stages of the conservation planning process. Often, the current plant composition does not entirely match any particular plant community (as described in this ecological site description). Because of this, a field visit is recommended, in all cases, to document plant composition and production. More precise carrying capacity estimates should eventually be calculated using this information along with animal preference data, particularly when grazers other than cattle are involved. Under more intensive grazing management, improved harvest efficiencies can result in an increased carrying capacity. If distribution problems occur, stocking rates must be reduced to maintain plant health and vigor.

Plant Community Production Carrying Capacity*

(lb./ac) (AUM/ac)

Bluebunch wheatgrass, Slimstem muhly, Threetip sagebrush 550 .2

Mixed Brush/Grass 450 .15

Low Plant Density, Decadent Plants 500 .15

Threetip sagebrush, Sandberg bluegrass, Threadleaf sedge 250 .08

* - Continuous, season-long grazing by cattle under average growing conditions.

Grazing by domestic livestock is one of the major income-producing industries in the area. Rangeland in this area may provide yearlong forage for cattle, sheep, or horses. During the dormant period, the forage for livestock use needs to be supplemented with protein because the quality does not meet minimum livestock requirements.

Hydrological functions

Water is the principal factor limiting forage production on this site. This site is dominated by soils in hydrologic group B and C, with localized areas in hydrologic group D. Infiltration ranges from moderate to moderately rapid. Runoff potential for this site varies from moderate to high because of the shallow soils and low available water capacity. In many cases, areas with greater than 75% ground cover have the greatest potential for high infiltration and lower runoff, however, with AWC of 0.25-0.5 inch and soil depth of 4-10 inches, runoff potential will still be quite high. An example of an exception would be where short-grasses form a strong sod and dominate the site. Areas where ground cover is less than 50% have the greatest potential to have reduced infiltration and higher runoff (refer to Part 630, NRCS National Engineering Handbook for detailed hydrology information).

Recreational uses

This site provides hunting opportunities for upland game species. The wide variety of plants which bloom from spring until fall have an esthetic value that appeals to visitors.

Wood products

No appreciable wood products are present on the site.

Other products

None noted.

Inventory data references

Inventory Data References (narrative)

Information presented here has been derived from NRCS clipping data and other inventory data. Field observations from range trained personnel was also used.

Inventory Data References

Data Source Number of Records Sample Period State County
SCS-RANGE-417 24 1963 -1987 WY Albany & others

Other references

Other sources used as references include: High Plains Regional Climate Center, USDA NRCS Water and Climate Center, USDA NRCS National Range and Pasture Handbook, and USDA NRCS Soil Surveys from various counties.

Rangeland health reference sheet

Interpreting Indicators of Rangeland Health is a qualitative assessment protocol used to determine ecosystem condition based on benchmark characteristics described in the Reference Sheet. A suite of 17 (or more) indicators are typically considered in an assessment. The ecological site(s) representative of an assessment location must be known prior to applying the protocol and must be verified based on soils and climate. Current plant community cannot be used to identify the ecological site.

Author(s)/participant(s)	
Contact for lead author	
Date	03/01/2005
Approved by	E. Bainter
Approval date	
Composition (Indicators 10 and 12) based on	Annual Production

Indicators

1. **Number and extent of rills:** Rills should not be present
-

2. **Presence of water flow patterns:** Barely observable

-
3. **Number and height of erosional pedestals or terracettes:** Essentially non-existent
-
4. **Bare ground from Ecological Site Description or other studies (rock, litter, lichen, moss, plant canopy are not bare ground):** Bare ground is 50-60% occurring in small areas throughout site
-
5. **Number of gullies and erosion associated with gullies:** Active gullies should be restricted to areas of concentrated water flow patterns on steeper slopes
-
6. **Extent of wind scoured, blowouts and/or depositional areas:** Small scoured sites may be observed
-
7. **Amount of litter movement (describe size and distance expected to travel):** Litter movement is little to none based on topography and water flow patterns
-
8. **Soil surface (top few mm) resistance to erosion (stability values are averages - most sites will show a range of values):** Plant cover and litter is at 50% or greater of soil surface and maintains soil surface integrity. Soil Stability class is anticipated to be 4 or greater.
-
9. **Soil surface structure and SOM content (include type of structure and A-horizon color and thickness):** Use Soil Series description for depth and color of A-horizon
-
10. **Effect of community phase composition (relative proportion of different functional groups) and spatial distribution on infiltration and runoff:** Grass canopy and basal cover should reduce raindrop impact and slow overland flow providing increased time for infiltration to occur. Infiltration is moderate.
-
11. **Presence and thickness of compaction layer (usually none; describe soil profile features which may be mistaken for compaction on this site):** No compaction layer or soil surface crusting should be present.
-
12. **Functional/Structural Groups (list in order of descending dominance by above-ground annual-production or live foliar cover using symbols: >>, >, = to indicate much greater than, greater than, and equal to):**
- Dominant:
- Sub-dominant:
- Other:
- Additional: Mid stature Cool Season Grasses > Shrubs > Forbs
-

13. **Amount of plant mortality and decadence (include which functional groups are expected to show mortality or decadence):** Very Low

14. **Average percent litter cover (%) and depth (in):** Average litter cover is 15-25% with depths of 0.25 to 0.5 inches

15. **Expected annual annual-production (this is TOTAL above-ground annual-production, not just forage annual-production):** 550 lbs/ac

16. **Potential invasive (including noxious) species (native and non-native). List species which BOTH characterize degraded states and have the potential to become a dominant or co-dominant species on the ecological site if their future establishment and growth is not actively controlled by management interventions. Species that become dominant for only one to several years (e.g., short-term response to drought or wildfire) are not invasive plants. Note that unlike other indicators, we are describing what is NOT expected in the reference state for the ecological site:** Threadleaf sedge, Threetip sagebrush, Unpalatable Forbs, Species found on Noxious Weed List

17. **Perennial plant reproductive capability:** All species are capable of reproducing
