

## Ecological site R052XN162MT Clayey (Cy) 10-14" p.z.

Last updated: 1/24/2024  
Accessed: 04/25/2024

---

### General information

**Provisional.** A provisional ecological site description has undergone quality control and quality assurance review. It contains a working state and transition model and enough information to identify the ecological site.

### MLRA notes

Major Land Resource Area (MLRA): 052X–Brown Glaciated Plains

The Brown Glaciated Plains, MLRA 52, is an expansive, agriculturally and ecologically significant area. It consists of approximately 14.5 million acres and stretches across 350 miles from east to west, encompassing portions of 15 counties in north-central Montana. This region represents the southwestern limit of the Laurentide Ice Sheet and is considered to be the driest and westernmost area within the vast network of glacially derived prairie pothole landforms of the northern Great Plains. Elevation ranges from 2,000 feet (610 meters) to 4,600 feet (1,400 meters).

Soils are primarily Mollisols, but Entisols, Inceptisols, Alfisols, and Vertisols are also common. Till from continental glaciation is the predominant parent material, but alluvium and bedrock are also common. Till deposits are typically less than 50 feet thick, and in some areas glacially deformed bedrock occurs at or near the soil surface (Soller, 2001). Underlying sedimentary bedrock largely consisting of Cretaceous shale, sandstone, and mudstone (Vuke et al., 2007) is commonly exposed on hillslopes, particularly along drainageways. Significant alluvial deposits occur along glacial outwash channels and major drainages, including portions of the Missouri, Teton, Marias, Milk, and Frenchman Rivers. Large glacial lakes, particularly in the western half of the MLRA, deposited clayey and silty lacustrine sediments (Fullerton et al., 2013).

Much of the western portion of this MLRA was glaciated towards the end of the Wisconsin age, with the maximum glacial extent occurring approximately 20,000 years ago (Fullerton et al., 2004). The result is a geologically young landscape that is predominantly a level till plain interspersed with lake plains and dominated by soils in the Mollisol and Vertisol orders. These soils are very productive and generally are well suited to dryland farming. Much of this area is aridic-ustic. Crop-fallow dryland wheat farming is the predominant land use. Areas of rangeland typically are on steep hillslopes along drainages.

The rangeland, much of which is native mixedgrass prairie, increases in abundance in the eastern half of the MLRA. The Wisconsin-age till in the north-central part of this area typically formed large disintegration moraines with steep slopes and numerous poorly drained potholes. A large portion of Wisconsin-age till occurring on the type of the level terrain that would typically be optimal for farming has large amounts of less-suitable sodium-affected Natrustalfs. Significant portions of Blaine, Phillips, and Valley Counties were glaciated approximately 150,000 years ago during the Illinoian age. Due to erosion and dissection of the landscape, many of these areas have steeper slopes and more exposed bedrock than areas glaciated during the Wisconsin age (Fullerton and Colton, 1986).

While much of the rangeland in the aridic-ustic portion of MLRA 52 is classified as belonging to the “dry grassland” climatic zone, sites in portions of southern MLRA 52 may belong to the “dry shrubland” climatic zone. The dry shrubland zone represents the northernmost extent of the big sagebrush (*Artemisia tridentata*) steppe on the Great Plains. Because similar soils occur in both southern and northern portions of the MLRA, it is currently hypothesized that climate is the primary driving factor affecting big sagebrush distribution in this area. However, the precise factors are not yet fully understood.

Sizeable tracts of largely unbroken rangeland in the eastern half of the MLRA and adjacent southern Saskatchewan

are home to the Northern Montana population of greater sage-grouse (*Centrocercus urophasianus*), and large portions of this area are considered to be a Priority Area for Conservation (PAC) by the U.S. Fish and Wildlife Service (U.S. Fish and Wildlife Service, 2013). This population is unique among sage grouse populations in the fact that many individuals overwinter in the big sagebrush steppe (dry shrubland) in the southern portion of the MLRA and then migrate to the northern portion of the MLRA, which lacks big sagebrush (dry grassland), to live rest of the year (Smith, 2013).

Areas of the till plain near the Bearpaw and Highwood Mountains as well as the Sweetgrass Hills and Rocky Mountain foothills are at higher elevations, receive higher amounts of precipitation, and have a typical-ustic moisture regime. These areas have significantly more rangeland production than the drier aridic-ustic portions of the MLRA and have enough moisture to produce crops annually rather than just bi-annually, as in the drier areas. Ecological sites in this higher precipitation area are classified as the moist grassland climatic zone.

## Classification relationships

NRCS Soil Geography Hierarchy

- Land Resource Region: Northern Great Plains
- Major Land Resource Area (MLRA): 052 Brown Glaciated Plains
- Climate Zone: Dry Shrubland

National Hierarchical Framework of Ecological Units (Cleland et al., 1997; McNab et al., 2007)

- Domain: Dry
- Division: Temperate Steppe
- Province: Great Plains-Palouse Dry Steppe Province 331
- Section: Northwestern Glaciated Plains 331D
- Subsection: Montana Glaciated Plains 331Dh
- Landtype association/Landtype phase: N/A

National Vegetation Classification Standard (Federal Geographic Data Committee, 2008)

- Class: Xeromorphic Woodland, Scrub and Herb Vegetation Class (3)
- Subclass: Cool Semi-Desert Scrub and Grassland Subclass (3.B)
- Formation: Cool Semi-Desert Scrub and Grassland Formation (3.B.1)
- Division: Cool Semi-Desert Scrub and Grassland Division (3.B.1.Ne)
- Macrogroup: *Artemisia tridentata* - *Artemisia tripartita* ssp. *tripartita* - *Purshia tridentata* Steppe and Shrubland Macrogroup (3.B.1.Ne.3)
- Group: *Artemisia tridentata* - *Artemisia tripartita* - *Purshia tridentata* Big Sagebrush Steppe and Shrubland Group (3.B.1.Ne.3.b)
- Alliance: *Artemisia tridentata* ssp. *wyomingensis* Mesic Steppe and Shrubland Alliance
- Association: *Artemisia tridentata* ssp. *wyomingensis* / *Pascopyrum smithii* Shrub Grassland

EPA Ecoregions

- Level 1: Great Plains (9)
- Level 2: West-Central Semi-Arid Prairies (9.3)
- Level 3: Northwestern Glaciated Plains (42)
- Level 4: North-Central Brown Glaciated Plains (42o) and Glaciated Northern Grasslands (42j)

## Ecological site concept

This ecological site occurs on till plains, lake plains, and low hills where slopes are less than 15 percent. This site can be found on any slope shape, but concave or linear is most common.

The distinguishing characteristic of this site is that it contains greater than 35 percent, but not more than 45 percent, clay in the upper 4 inches of soil. Soils for this ecological site are typically moderately deep to very deep (more than 20 inches to bedrock) and derived from shale residuum, clayey till, or glaciofluvial deposits. Soil surface textures (0 to 4 inches) are typically clay, clay loam, silty clay, or silty clay loam, and the soils typically have an ochric epipedon. This site is typically nonacid, with pH values greater than 5.6 throughout the soil profile. Characteristic vegetation is western wheatgrass (*Pascopyrum smithii*), green needlegrass (*Nassella viridula*), Nuttall's saltbush (*Atriplex nuttallii*), greasewood (*Sarcobatus vermiculatus*), and silver sagebrush (*Artemisia cana*).

## Associated sites

R052XN161MT	<b>Silty (Si) 10-14" p.z.</b> Similar landscape position; different species composition and soil texture.
R052XN164MT	<b>Clayey-Steep (CyStp) 10-14" p.z.</b> Slopes >15%; less forage production; different species composition.
R052XN166MT	<b>Overflow (Ov) 10-14" p.z.</b> Receives additional run-in moisture from surrounding landscape; different species composition, higher productivity.
R052XN178MT	<b>Shallow (Sw) 10-14" p.z.</b> Soil depth less than or equal to 20 inches to a restrictive layer; less forage production.

## Similar sites

R053AE061MT	<b>Clayey (Cy) (Legacy) RRU 53AE</b> Decrease in total annual production of bluebunch wheatgrass (it becomes an insignificant grass). Increase in other wheatgrasses and/or needlegrass.
R052XC205MT	<b>Clayey (Cy) 10-14" p.z.</b> Decrease in total annual production of bluebunch wheatgrass, but bluebunch is a co-dominant grass. Increase in other wheatgrasses and/or needlegrass.

**Table 1. Dominant plant species**

Tree	Not specified
Shrub	(1) <i>Krascheninnikovia lanata</i> (2) <i>Atriplex nuttallii</i>
Herbaceous	(1) <i>Nassella viridula</i> (2) <i>Pseudoroegneria spicata</i>

## Physiographic features

This site usually consists of deep soils on flood plains and fans, and moderately deep soils on uplands. Slopes vary from 1- 15%, but are usually less than 8%. Elevations generally range from 2,000 to 3,500 feet.

**Table 2. Representative physiographic features**

Landforms	(1) Flood plain (2) Alluvial fan (3) Lava flow
Runoff class	Medium
Flooding frequency	None
Ponding frequency	None
Elevation	2,000–3,500 ft
Slope	1–8%
Aspect	W, NW, N, NE, E, SE, S, SW

**Table 3. Representative physiographic features (actual ranges)**

Runoff class	Not specified
Flooding frequency	Not specified
Ponding frequency	Not specified
Elevation	1,875–4,000 ft

### Climatic features

A semi-arid, temperate climate characterizes the Glaciated Plains. The predominance of cool season species has evolved to take advantage of the precipitation regime that peaks in late spring-early summer (June). Seventy-five percent of the annual precipitation usually falls as steady, soaking, frontal system rains. Summer rains usually come with thunderstorms. Precipitation is the most important factor influencing production (Heitschmidt et al 2005). Severe drought occurs on average in two out of every ten years (Cooper, et al., 2001).

**Table 4. Representative climatic features**

Frost-free period (characteristic range)	85-123 days
Freeze-free period (characteristic range)	116-142 days
Precipitation total (characteristic range)	10-14 in
Frost-free period (average)	94 days
Freeze-free period (average)	125 days
Precipitation total (average)	12 in

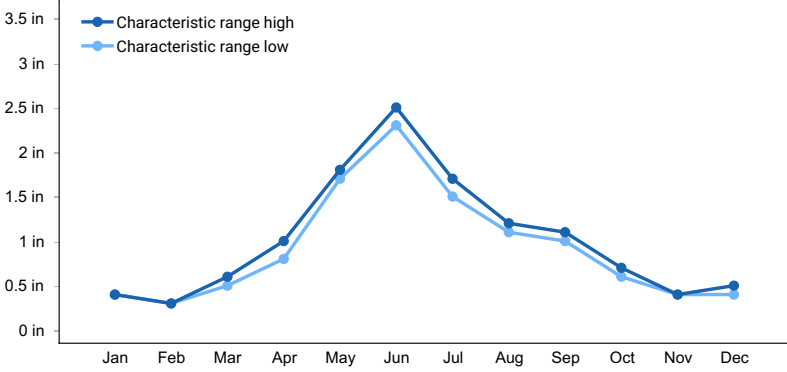

**Figure 1. Monthly precipitation range**

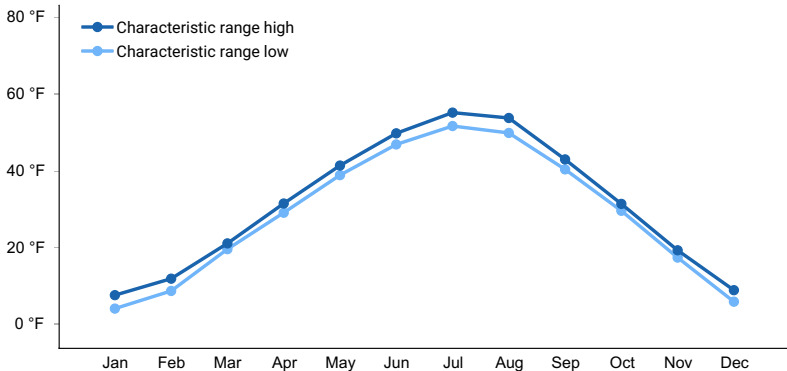

**Figure 2. Monthly minimum temperature range**

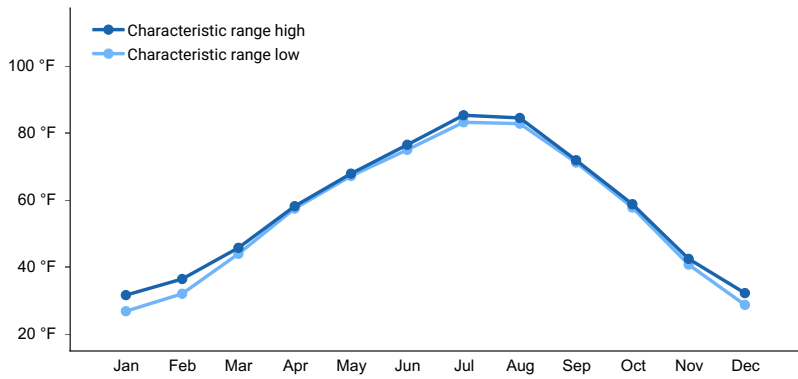

**Figure 3. Monthly maximum temperature range**

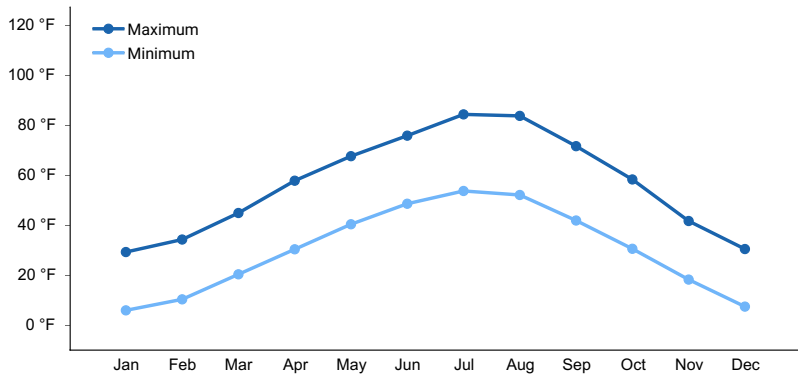

**Figure 4. Monthly average minimum and maximum temperature**

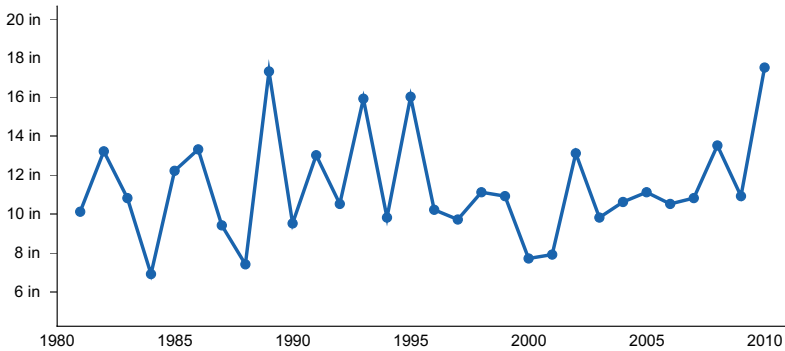

**Figure 5. Annual precipitation pattern**

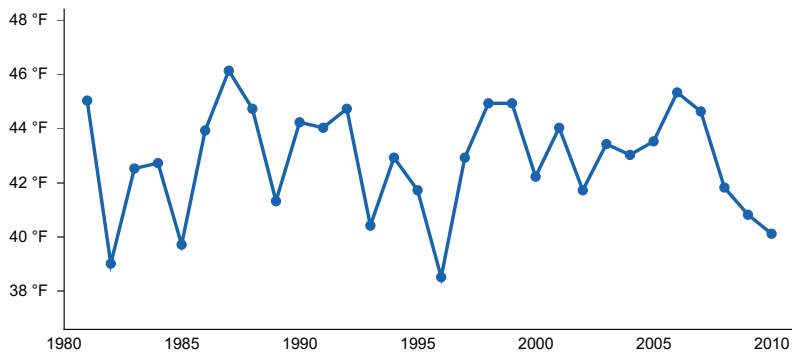

**Figure 6. Annual average temperature pattern**

### Climate stations used

- (1) CHESTER [USC00241692], Chester, MT
- (2) GLASGOW [USW00094008], Glasgow, MT
- (3) HAVRE CITY CO AP [USW00094012], Havre, MT

- (4) SHELBY [USC00247500], Shelby, MT

## Influencing water features

This site is not influenced by water from streams.

## Wetland description

This site is not influenced by water from wetlands.

## Soil features

These soils formed in place in glacial till underlain by shale. Some of the soils formed in material derived from shale or in alluvium derived from glacial till or shale. The alluvium was deposited in the valleys on some of the bordering uplands, low terraces, fans and flood plains. The light brownish gray clay surface layer of these soils is usually less than 5 inches in depth. The clay soils are more than 20 inches deep. Soils are well drained. Permeability is very slow. Soil ph varies from 6.6-8.4. This site is characterized by the following soil components: Abor, Lohler, Marias, Bacovey, and Marvan.

**Table 5. Representative soil features**

Parent material	(1) Alluvium (2) Till (3) Residuum–shale
Surface texture	(1) Clay loam (2) Silty clay loam (3) Silty clay
Family particle size	(1) Fine
Drainage class	Moderately well drained to well drained
Permeability class	Very slow
Soil depth	20–78 in
Surface fragment cover ≤3"	0%
Surface fragment cover >3"	0%
Available water capacity (Depth not specified)	4–5 in
Electrical conductivity (Depth not specified)	0–2 mmhos/cm
Sodium adsorption ratio (Depth not specified)	0–2
Soil reaction (1:1 water) (Depth not specified)	6.1–8.4
Subsurface fragment volume ≤3" (Depth not specified)	0–11%
Subsurface fragment volume >3" (Depth not specified)	0–2%

## Ecological dynamics

This ecological site developed under Northern Great Plains climatic conditions, geological parent materials, fire, biotic factors, and under the natural influence of herbivory. Research consistently shows that precipitation is the principle factor altering productivity on ecological sites in the Northern Great Plains (Heitschmidt et al. 2005). The same authors concluded that grazing reduces herbage standing crop, whereas its effects on above ground net primary production varies with timing of grazing and precipitation events, along with the functional and structural composition of the plant community.

It is theorized that these lands burned on a natural interval of 10-12 years (Frost 1998). Fires were ignited by lightning and by early Americans whom were striving to manipulate their environment. Periodic burns would have favored grasses over shrubs, adversely impacted dense clubmoss, attracted herbivory into an area, and altered nutrient cycling and the hydrologic cycle.

The resultant historic climax plant community (HCPC) is the basis for plant community interpretations. The HCPC was determined by evaluating relic areas, and other areas protected from excessive disturbance. The HCPC is comprised of a mixture of tall and medium height cool and warm season grasses, native forbs and native shrubs. About 80% of the annual production is from grasses and grasslike plants, most of which are produced during the cool season. Forbs and shrubs contribute 15% and 5%, respectively to total annual production. Total vegetative production averages 1300 lbs/ac in normal years, 1800 lbs/ac during favorable years, and 900 lbs/ac during unfavorable years.

This ecological site is highly resistant and resilient to disturbance as it has only minor soil limitations for plant growth. Departures from HCPC generally result from management actions, drought, colonization and recruitment of noxious weeds, and a change in the natural fire regime. Under continued adverse impacts, vegetative vigor declines and the HCPC species are gradually out-competed by lower-successional species. This shift in species composition is most evident as the deep-rooted cool season perennial grasses (such as green needlegrass and western/thickspike wheatgrasses) are replaced by short warm season grasses (blue grama, sandberg bluegrass), fringed sagewort (a half-shrub), and forbs including western wallflower, scarlet globemallow, western yarrow and biscuitroot. The dominance of these short grasses, non-nitrogenous-fixing forbs, and warm season half-shrubs disrupts ecological processes, impairs the biotic integrity of the site, and restricts the system's ability to recover to higher seral states. Thus, the site loses much of its resiliency.

#### State and Transition Diagram

Traditional theories of plant succession leading to a single climax community are inadequate for understanding the complex successional pathways of this ecological site in the glaciated plains (Briske et al 2005). This site is more aptly described using state-and-transition vegetation dynamics in a non-linear framework. A "state" is an alternative, persistent vegetation community that is not simply reversible in the linear successional framework. States are depicted as seral stages, while pathways between states are "transitions." The latter can be transient or persisting (crosses a threshold). Transitions are triggered by climatic events, fire, grazing, farming, burning, etc.

Three important plant communities and the successional pathways that commonly occur within the reference state (State 1), are shown in the following diagram. In addition, the transition from Plant Community B (State 1) to Plant Community C (State 2), and a transition from State 1 to State 3 are also illustrated. Ecological processes are discussed in the plant community descriptions which follow the diagram.

#### State and transition model

# Clayey 10-14" p.z. RRUs 52XN, 52XC, 53AE

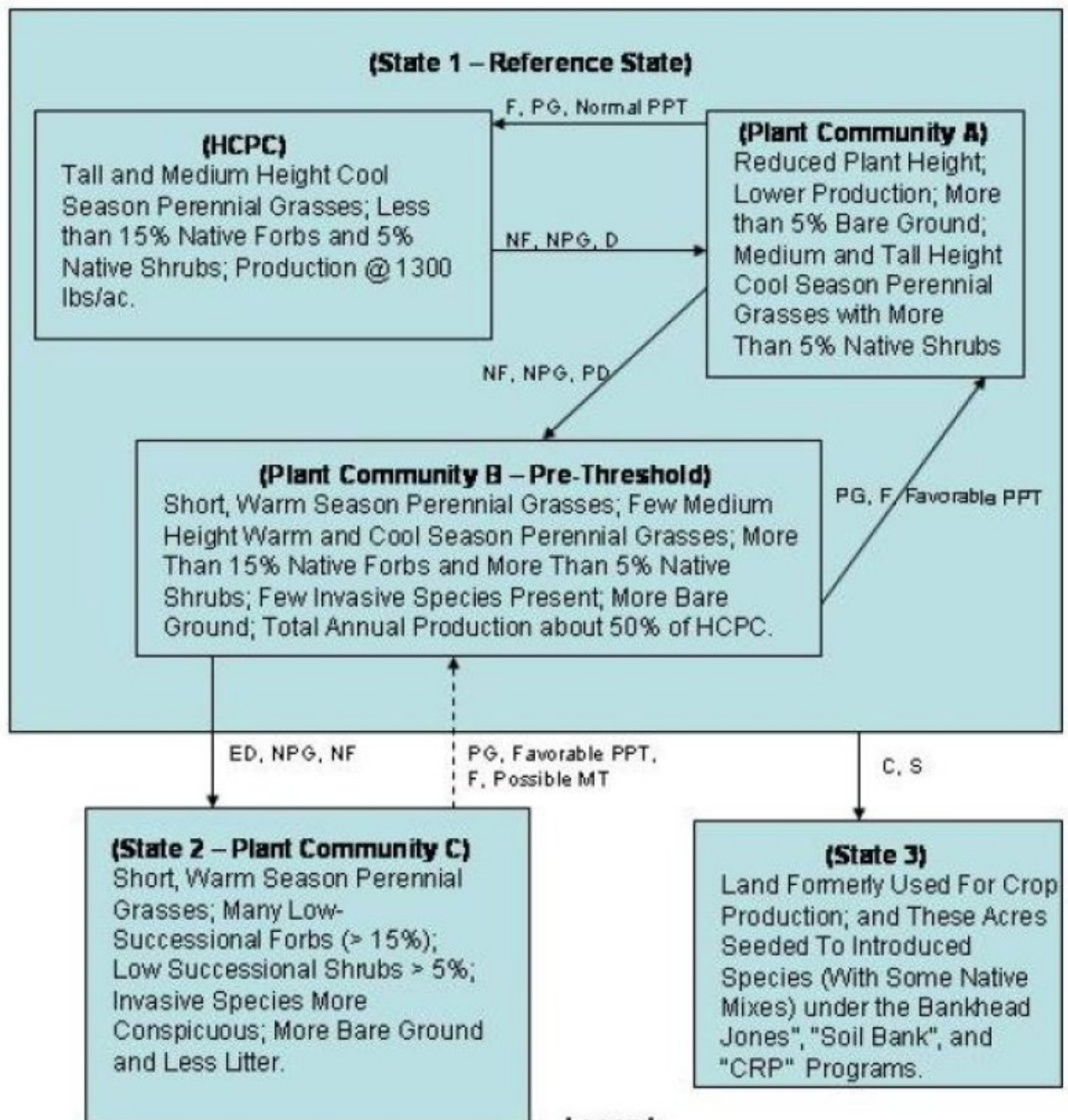

**Legend:**

- NF – No Fire
- F – Fire (natural interval 5-7 yrs)
- NPG – Non-Prescribed Grazing
- PG – Prescribed Grazing
- PPT -- Precipitation
- D – Drought (3-5 years)
- PD – Prolonged Drought (5-7 years)
- ED – Extended Drought (>7 years)
- MT – Mechanical Treatment (NRCS Jobsheet 548)
- C- Cultivated and Farmed
- S – Seeding



**State 1**  
**Reference State**

**Community 1.1**

**Historic Climax Plant Community (HCPC) Tall- and medium-height cool-season perennial grasses, less than 15 percent native forbs, and 5 percent native shrubs.**

Tall- and medium-height cool-season perennial grasses, less than 15 percent native forbs, and 5 percent native shrubs, production@1300 lbs/ac. The interpretive plant community for this site is the Historic Climax Plant Community (HCPC). Cool season, tall and mid-grasses (such as bluebunch wheatgrass, green needlegrass, western wheatgrass, and thickspike wheatgrass) dominate the HCPC. Prairie junegrass is the most common short grass. Other short grasses and sedges include plains reedgrass, threadleaf sedge and needleleaf sedge. Bluebunch wheatgrass is a dominant species on the Clayey 10-14" p.z. site in the northern Glaciated Plains. Blue grama is the only common warm season grass. The range inventories on Fort Peck and Fort Belknap Reservations (2001-2004) did not report any sideoats grama or little bluestem on this site. Grasses represent about 80% of the total annual production in the community. Dotted gayfeather, American vetch, white prairie clover and purple prairie clover are warm season forbs that commonly occur on these Clayey 10-14" p.z. sites. American vetch and the prairie clovers are nitrogen-fixing species, and are also valuable forage producing plants. Groundplum milkvetch, scurfpea and prairie thermopsis are lower-successional forbs that have the ability to fix nitrogen. White milkwort, biscuitroot, wild onion and western yarrow may be present as minor components of the plant community. Forbs represent about 15% of the total annual production. Winterfat and Nuttall's saltbush are common warm and cool season shrubs, respectively. They are valuable forage for wildlife and livestock. Silver sagebrush and fringed sagewort, two additional warm season shrub species, may represent a minor component of the HCPC. One would not expect to find more than a trace of broom snakeweed and pricklypear cactus in the HCPC. Very few cool season shrubs grow on the site. Overall, shrubs account for about 5% of the annual plant production. Range inventory data collected (in 2001 and 2004) on the Fort Peck and Fort Belknap Indian Reservations, and previous clipping studies by the NRCS indicate total annual production averages 1300 lbs/ac during normal years. Production varies from 900 to 1800 lbs/ac in unfavorable and favorable years, respectively. Average annual production is expected to increase and decrease, respectively on more mesic and xeric portions of the Glaciated plains. Although similarity indices (SI) >75% are expected to be associated with the HCPC, none were recorded during the recent range inventories on the two Reservations. This plant community is well adapted to the semi-arid, temperate climate that characterizes the glaciated plains. The predominance of cool season species has evolved to take advantage of the precipitation regime that peaks in late spring-early summer (June). Seventy-five percent of the annual precipitation usually falls as steady, soaking, frontal system rains. Summer rains usually come with thunderstorms. Precipitation is the most important factor influencing production. Severe drought occurs on average in two out of every ten years (Cooper, et al., 2001). Annual bromes and other annual species may invade the HCPC following a drought or period of non-prescriptive grazing. Continual adverse impacts over a period of several years will cause a shift in species composition from the mid and tall cool season grasses to warm season grasses and forbs/half-shrubs such as prairie junegrass, plains reedgrass, white milkwort, fringed sagewort, etc. With proper grazing management and/or normal precipitation, the desirable perennial plants regain vigor and competitiveness. The annual opportunistic species normally do not persist for more than a few years. Litter is in contact with 50-60% of the soil surface. Less than 5-10% of the soil surface should be bare, or unprotected by litter, rock, moss, and plant canopy. Rills should not be present and water flow patterns should be barely observable. Soil erosion by wind and water should be minimal.

**Table 6. Annual production by plant type**

Plant Type	Low (Lb/Acre)	Representative Value (Lb/Acre)	High (Lb/Acre)
Grass/Grasslike	720	1040	1440
Forb	135	195	270
Shrub/Vine	45	65	90
<b>Total</b>	<b>900</b>	<b>1300</b>	<b>1800</b>

**Table 7. Ground cover**

Tree foliar cover	0%
-------------------	----

Shrub/vine/liana foliar cover	0%
Grass/grasslike foliar cover	0%
Forb foliar cover	0%
Non-vascular plants	0-5%
Biological crusts	0-2%
Litter	55-65%
Surface fragments >0.25" and <=3"	0-3%
Surface fragments >3"	0-2%
Bedrock	0%
Water	0%
Bare ground	1-5%

**Table 8. Soil surface cover**

Tree basal cover	0%
Shrub/vine/liana basal cover	1-5%
Grass/grasslike basal cover	20-25%
Forb basal cover	5-10%
Non-vascular plants	0%
Biological crusts	0%
Litter	0%
Surface fragments >0.25" and <=3"	0%
Surface fragments >3"	0%
Bedrock	0%
Water	0%
Bare ground	0%

**Table 9. Canopy structure (% cover)**

Height Above Ground (Ft)	Tree	Shrub/Vine	Grass/ Grasslike	Forb
<0.5	–	0-20%	0-10%	0-40%
>0.5 <= 1	–	0-40%	0-30%	0-50%
>1 <= 2	–	0-30%	0-40%	0-8%
>2 <= 4.5	–	0-10%	0-20%	0-2%
>4.5 <= 13	–	–	–	–
>13 <= 40	–	–	–	–
>40 <= 80	–	–	–	–
>80 <= 120	–	–	–	–
>120	–	–	–	–

## Community 1.2

**Plant Community A Reduced plant height, lower production, more than 5 percent bare ground, medium- and tall-height cool-season perennial grasses with more than 5 percent native shrubs.**

Reduced plant height, lower production, more than 5 percent bare ground, medium- and tall-height cool-season perennial grasses with more than 5 percent native shrubs. A plant height shift to lower stature plants distinguishes Community A from the HCPC. Although cool season perennial grasses (bluebunch wheatgrass, western/thickspike wheatgrass and green needlegrass) still dominate the vegetative community, the percentage of short stature cool and warm season perennial plants such as prairie junegrass and blue grama has increased. Fringed sagewort and silver sagebrush often increase in abundance and contribute more than 5% of the total production. Total vegetative production decreases to about 1050 lbs/ac, or 80% of HCPC. Basal cover provided by plants decreases to 25%, while litter cover decreases to 40%. Careful examination will yield slight evidence of rills and surface water runoff.

### **Community 1.3**

#### **Plant Community B - Pre-threshold Short, warm-season perennial grasses, few medium-height warm- and cool-season perennial grasses, more than 15% native forbs and more than 5% native shrubs, few invasive species present, more bare ground.**

Short, warm-season perennial grasses, few medium-height warm- and cool-season perennial grasses, more than 15% native forbs and more than 5% native shrubs, few invasive species present, more bare ground, total annual production about 50% of HCPC. Vegetative production averages about 800 lbs/ac in this Community. The community is dominated by short, warm and cool season perennial grasses. Production of western and thickspike wheatgrass, green needlegrass, and bluebunch wheatgrass is greatly reduced. The production, composition and diversity of cool season mid and tall grasses in the plant community have been significantly reduced. Production of hairy goldenaster, western yarrow, hoods phlox, scurfpea, and other lower-successional native forbs increased. Fringed sagewort and silver sagebrush make up more than 5% of the total vegetative production. Plant replacement (seedlings and young plants) will be weighted in favor of opportunistic warm season species. Recruitment of mid and tall height cool season grasses is limited to only be a few seedlings and young plants. Japanese brome and other annual grasses occur on the site. Japanese brome density will be highest in microsites, where there is excess moisture or an abundance of litter, or in disturbed areas (rodent mounds, roads, trails, etc.). This community is characterized by a functional shift from a cool season dominant to a mix of warm and cool season species. The warm season plants are less well-adapted to exploit the precipitation and temperature conditions during May and June. Consequently, less solar energy is captured and converted to carbohydrates. The transfer of energy through the site has been adversely impacted. The site also tends to be more xeric as evaporation and runoff increases. Plant community B is called the "pre-threshold community." It is critical that this community be recognized and management strategies implemented to prevent further regression. Although this community can improve to either Community A or HCPC through successional processes, further disturbances will result in regression to a lower state. Succession from a lower state (State 2) to State 1 is unlikely without significant inputs into the system.

### **Pathway 1.1A**

#### **Community 1.1 to 1.2**

No fire, non-prescribed grazing, drought (3 to 5 years) Non-prescribed grazing, drought, insect infestations (grasshopper, etc) and/or a cessation of fire will cause regression from HCPC to Community A.

### **Pathway 1.2A**

#### **Community 1.2 to 1.1**

Fire (natural interval 5 to 7 years), prescribed grazing, normal precipitation Favorable growing conditions, the implementation of prescribed grazing, or the reintroduction of periodic fire into the system will move Plant Community A to the HCPC. This succession can occur within a couple of years.

### **Pathway 1.2B**

#### **Community 1.2 to 1.3**

No fire, non-prescribed grazing, prolonged drought (5 to 7 years) Community A will regress to Community B under non-prescribed grazing, prolonged drought (5 to 7 years), or an extended period of no fire (greater than 7 years). The rate of regression varies with the intensity and frequency of disturbances

### **Pathway 1.3A**

## **Community 1.3 to 1.2**

Prescribed grazing, fire (natural interfall 5 to 7 years), favorable precipitation The Clayey 10-14" p.z. site is resistant within the reference state. It is also resilient. Prescribed grazing, the re-implementation of the natural fire regime and/or a period of favorable precipitation will induce successional changes toward the HCPC. Succession will normally occur within a few years.

## **State 2**

### **Degraded State**

#### **Community 2.1**

**Plant Community C Short, warm-season perennial grasses, many low-successional forbs (greater than 15 percent), low successional shrubs greater than 5 percent, invasive species more conspicuous, more bare ground and less litter.**

Short, warm-season perennial grasses, many low-successional forbs (greater than 15 percent), low successional shrubs greater than 5 percent, invasive species more conspicuous, more bare ground and less litter. State 2 Plant Community C is dominated by warm season species (blue grama, prairie junegrass, sandberg bluegrass and other short grasses). Both the percentage of total forbs on the site and the percentage of warm season forbs, with respect to percent of cool season forbs have increased. Curlycup gumweed, a warm season biennial plant will often establish in disturbed areas. Silver sagebrush may either increase or decrease in this State; however fringed sagewort normally increases. Prickly pear and brittle cacti usually increase in abundance. Broom snakeweed may encroach onto the site. Annual grasses such as Japanese brome and cheatgrass often increase in abundance until they actually dominate portions of the community. Dense clubmoss, a low growing, vascular cryptogam forms a carpet-like mat that provides up to 30% ground cover in some of these communities. Total vegetative production in a normal year is usually less than 500 lbs/ac. Many resource concerns exist in this State. There is little or no regeneration of cool season perennial grasses and cool season forbs/shrubs. Litter is inadequate to protect the soil from erosion by wind and water. Surface erosion is moderate to severe, and there is more bare ground than expected. Rills, water flow patterns, and pedestals are evident.

## **State 3**

### **Converted State**

#### **Community 3.1**

**Seeded Community Land formerly used for crop production, and these acres seeded to introduced species (with some native mixes) under Bankhead Jones, Soil Bank, and CRP Programs.**

Land formerly used for crop production, and these acres seeded to introduced species (with some native mixes) under Bankhead Jones, Soil Bank, and CRP Programs. More than one million acres of former cropland in the Glaciated Plains have been seeded to introduced and native species. These seedings resulted from society's concerns regarding land stewardship and erosion, and have been largely funded by the Federal Government. The government programs have spanned from the 1940s (Bankhead Jones Act) to the present (Conservation Reserve Program - CRP). Crested wheatgrass was the primary species seeded under the direction of the Bankhead Jones Act. Crested wheatgrass, intermediate wheatgrass, smooth brome and some native grasses were seeded during several Soil Bank Programs of the 1960-1970 era. Both introduced species and native species were seeded during the CRP (1985-present). There are over 220,000 acres of CRP in Valley County alone. The future of these Communities is not predicted in the S&T model. Depending on government programs and agricultural prices, these lands could stay in permanent vegetation with limited haying and grazing, be used as pasture for grazing livestock, or be converted to cropland.

## **Transition T1A**

### **State 1 to 2**

Extended drought (greater than 7 years), non-prescribed grazing, no fire Community B is not highly resistant to regression. In comparison to higher seral stages there is less vegetative production, less litter, and increased bare ground. Extended drought (longer than 7 consecutive years) and non-prescribed grazing can quickly cause

regression to a lower state (State 2).

## Transition T1B State 1 to 3

Cultivated and farmed, seeding

## Restoration pathway R2A State 2 to 1

Prescribed grazing, favorable precipitation, fire (natural interval 5 to 7 years), possible mechanical treatment (NRCS job sheet 548) This plant community is resistant to change, it is a steady state. The short grasses tend to form a sod that prevents seedling establishment of higher successional species. Less than 10% of the seed bank in State 2 is comprised of seed from cool season perennial plants (Romo and Bai 2004). Thus, potential for succession is limited without significant inputs. Prescribed grazing minimizes the risk of further regression and enhances the potential for succession to State 1. The combination of prescribed grazing, a natural fire regime, and a prolonged period of favorable precipitation may allow significant succession in communities that have less than 20% clubmoss cover. This potential is depicted with the dashed line in the state and transition model. . Mechanical treatments may be feasible in areas where potential erosion is not a concern. However, mechanical treatments are not normally recommended on soils with a clay content > 60%. Grazing management practices following a mechanical treatment must be prescribed to address deferment, stocking rates, season of grazing, and other considerations (NRCS Conservation Practice 548). Failure to do so will adversely affect economic returns and is likely to result in retrogression rather than plant succession.

## Additional community tables

Table 10. Community 1.1 plant community composition

Group	Common Name	Symbol	Scientific Name	Annual Production (Lb/Acre)	Foliar Cover (%)
<b>Grass/Grasslike</b>					
1	<b>Cool-season Bunchgrasses</b>			690–1110	
	green needlegrass	NAVI4	<i>Nassella viridula</i>	390–590	–
	bluebunch wheatgrass	PSSP6	<i>Pseudoroegneria spicata</i>	300–520	–
2	<b>Rhizomatous Wheatgrasses</b>			390–590	
	western wheatgrass	PASM	<i>Pascopyrum smithii</i>	195–325	–
	tufted wheatgrass	ELMA7	<i>Elymus macrourus</i>	195–325	–
3	<b>Miscellaneous Grasses</b>			13–130	
	threadleaf sedge	CAFI	<i>Carex filifolia</i>	13–65	–
	needleleaf sedge	CADU6	<i>Carex duriuscula</i>	13–65	–
	Sandberg bluegrass	POSE	<i>Poa secunda</i>	13–65	–
	prairie Junegrass	KOMA	<i>Koeleria macrantha</i>	13–65	–
	plains reedgrass	CAMO	<i>Calamagrostis montanensis</i>	13–65	–
	blue grama	BOGR2	<i>Bouteloua gracilis</i>	13–65	–
	Grass, native	2GN	<i>Grass, native</i>	13–65	–
<b>Forb</b>					
4	<b>Dominant Forbs</b>			13–65	
	dotted blazing star	LIPU	<i>Liatris punctata</i>	13–65	–
	American vetch	VIAM	<i>Vicia americana</i>	13–65	–
5	<b>Clovers</b>			26–130	
	purple prairie clover	DAPU5	<i>Dalea purpurea</i>	13–65	–
	white prairie clover	DACA7	<i>Dalea candida</i>	13–65	–

6	<b>Miscellaneous Forbs</b>			0-100	
	beardtongue	PENST	<i>Penstemon</i>	0-65	-
	Missouri goldenrod	SOMI2	<i>Solidago missouriensis</i>	0-65	-
	common yarrow	ACMI2	<i>Achillea millefolium</i>	0-65	-
	aster	ASTER	<i>Aster</i>	0-65	-
	scarlet globemallow	SPCO	<i>Sphaeralcea coccinea</i>	0-65	-
	scurfpea	PSORA2	<i>Psoralegium</i>	0-65	-
	hairy false goldenaster	HEVI4	<i>Heterotheca villosa</i>	0-65	-
	upright prairie coneflower	RACO3	<i>Ratibida columnifera</i>	0-65	-
	prairie thermopsis	THRH	<i>Thermopsis rhombifolia</i>	0-65	-
	pussytoes	ANTEN	<i>Antennaria</i>	0-65	-
	bastard toadflax	COUM	<i>Comandra umbellata</i>	0-65	-
	white milkwort	POAL4	<i>Polygala alba</i>	0-65	-
	milkvetch	ASTRA	<i>Astragalus</i>	0-65	-
	groundplum milkvetch	ASCR2	<i>Astragalus crassicaucus</i>	0-65	-
	spiny phlox	PHHO	<i>Phlox hoodii</i>	0-65	-
	buckwheat	ERIOG	<i>Eriogonum</i>	0-65	-
	lesser spikemoss	SEDE2	<i>Selaginella densa</i>	0-65	-
	Forb, native	2FN	<i>Forb, native</i>	0-65	-
<b>Shrub/Vine</b>					
7	<b>Dominant Shrubs</b>			26-65	
	winterfat	KRLA2	<i>Krascheninnikovia lanata</i>	13-65	-
	Nuttall's saltbush	ATNU2	<i>Atriplex nuttallii</i>	13-65	-
8	<b>Miscellaneous Shrubs</b>			0-65	
	rubber rabbitbrush	ERNA10	<i>Ericameria nauseosa</i>	0-65	-
	silver sagebrush	ARCA13	<i>Artemisia cana</i>	0-65	-
	snowberry	SYMPH	<i>Symphoricarpos</i>	0-65	-
	prairie sagewort	ARFR4	<i>Artemisia frigida</i>	0-65	-
	rose	ROSA5	<i>Rosa</i>	0-65	-
	creeping juniper	JUHO2	<i>Juniperus horizontalis</i>	0-65	-
	Shrub (>.5m)	2SHRUB	<i>Shrub (&gt;.5m)</i>	0-65	-
	broom snakeweed	GUSA2	<i>Gutierrezia sarothrae</i>	0-1	-
	plains pricklypear	OPPO	<i>Opuntia polyacantha</i>	0-1	-
	brittle pricklypear	OPFR	<i>Opuntia fragilis</i>	0-1	-

## Animal community

### Livestock Management

This site evolved with trampling, defoliation (grasshoppers, jackrabbits, deer, elk, bison, antelope, prairie dogs and other herbivores), fire and drought. The site is highly resistant and resilient to disturbances which may alter its ecological processes. Following perturbations such as drought, which allows blue grama and other short grasses to increase at the expense of the mid and tall grasses, succession occurs during years of favorable precipitation. The site has the potential to produce 900-1800 lbs of forage per acre. Under typical grazing practices, very few livestock losses are reported from poisonous plants.

Forage production shows far greater variations in response to changes in annual precipitation than to different grazing intensities (Branson, 1985). However, proper stocking rates and a planned grazing system are needed to ensure that the site remains in a high seral or HCPC state. Without proper grazing management the mid-to-tall

grass community will regress to an early seral state (blue grama, prairie junegrass, sandberg bluegrass, hoods phlox, wooly plantain, and annual bromes).

Suggested stocking rates decrease from about 2.8 acres/AUM in the HCPC to about 10 acres/AUM in the early seral state (State 2). Plant succession in communities that are inhabited with prairie dogs is unlikely until the prairie dogs are controlled.

This site is usually grazed by livestock from May through October. Some ranchers utilize the Clayey 10-14" p.z. ecological site for fall and early winter grazing. However, storms are a threat. It is recommended that livestock either have access to adjacent wooded draws, or provide a good animal trail leading to headquarters for protection in winter and during storm events. Because of the predominant wheatgrass composition, the site is better-suited for cattle, rather than sheep grazing.

#### **Wildlife Interpretations**

The Clayey 10-14" p.z. ecological site that is in the reference state (State 1) provides forage for mule deer and antelope during most of the year. However, the overall forage potential is limited by the relatively low production and diversity of forbs and shrubs. Low shrub cover also limits the potential of the site for thermal and escape cover.

Most deer use on the site occurs along the edges where it borders woody draws, badland range sites, etc.

The species diversity and cover associated with the HCPC and with other communities in State #1 provides habitat for sharp-tailed grouse and other upland birds. Much of the use occurs along the ecotones between the Clayey 10-14" p.z. site and wooded draws where deciduous tree and shrub cover increase. The relative absence of big sagebrush limits the potential of this site for sage grouse habitat. The few sage grouse that exist in the Glaciated Plains are usually associated with silver sagebrush.

Species diversity and litter also provide favorable habitats for deer mice, rabbits and other small mammals. Golden eagles, redtail and ferruginous hawks are often circling over the landscape searching for prey.

Sites that are characterized by communities in mid to early seral stages are less suitable for big game, upland birds and small mammals. However, they are more suitable for prairie dogs. Prairie dog towns also have potential for use by burrowing owls, upland plovers, and other wildlife species.

#### **Hydrological functions**

Soils series in the Clayey 10-14" p.z. fall into the C and D hydrologic groups. Runoff potential varies from low to high, depending on slope, ground cover, and rangeland health. Infiltration rates also vary with environmental conditions.

Good hydrologic conditions exist on this site when it is in State #1. Canopy cover (grass, forbs and shrubs) is greater than 90% in these communities. Plant cover and litter are adequate to optimize infiltration and minimize runoff and erosion. Sites in early or low seral state (State #2) are generally considered to be in poor hydrologic condition.

#### **Recreational uses**

Hunters are probably the most common recreational user of Clayey 10-14" p.z. ecological sites. The site is also used by hikers and photographers.

#### **Wood products**

None

#### **Other products**

None

#### **Inventory data references**

Data Source Number of Records Sample Period State County  
SCS-Range-417 3 (1991-1992) MT Phillips  
ECS-1  
Modified Double Sampling 19 2001-2004 MT Blaine, Roosevelt,  
Sheridan,  
Phillips

## Other references

- Branson, Farrel A. 1985. Vegetation changes on western rangelands. Society for Range Management. Denver, Colo.
- Briske, D. D., S. D. Fuhlendorf, and F. E. Smeins. 2005. State-and-transition models, thresholds, and rangeland health: a synthesis of ecological concepts and perspectives. Rangeland Ecol. Manage. 58:1-10.
- Cooper, S.V., C. Jean and P. Hendricks. 2001. Biological survey of a prairie landscape in Montana's glaciated plains. Report to the Bureau of Land Management. Montana Natural Heritage Program, Helena.
- Heitschmidt, R. K., K. D. Klement, and M. R. Haferkamp. 2005. Interactive effects of drought and grazing on Northern Great Plains rangelands. Rangeland Ecol. Manage. 58:11-19.
- Romo, J. T., and Y. Bai. 2004. Seed bank and plant community composition, mixed prairie of Saskatchewan. J. Range Manage. 57:300-304.
- USDI BLM USGS and USDA NRCS. 2000. Interpreting indicators of rangeland health. Tech. Ref. 1734-6.

## Contributors

Kirt Walstad

## Approval

Kirt Walstad, 1/24/2024

## Acknowledgments

### Site Description Revision(s)

This 2005 revision replaces the following technical range site descriptions in Section II-E-8 of the NRCS Field Office Technical Guide:

Clayey 10-14" p.z. – Western Glaciated Plains (RRU 52XN), dated August 1981.

This 2005 revision incorporates the State and Transition Model theory, additional data on site productivity, and an improved understanding of many rangeland health indicators.

### Site Description Approval

This ecological site description is approved with the understanding that it is no more than another step in our continual effort to update the NRCS ecological database. In order to facilitate the process, NRCS field personnel are encouraged to forward existing information and/or new data that can be used to improve the utility of this site description. Please forward the information and data to the State Rangeland Management Specialist.

### Author Date Approval Date

Dr. John Lacey 02/23/2005 Loretta J. Metz 03/19/2005

Maxine Rasmussen, Area RMS, Glasgow, MT

Jon Siddoway, Area RMS, Great Falls, MT

Rick Bandy, Area RSS, Great Falls, MT

Greg Snell, Area RSS, Glasgow, MT

## Rangeland health reference sheet

Interpreting Indicators of Rangeland Health is a qualitative assessment protocol used to determine ecosystem condition based on benchmark characteristics described in the Reference Sheet. A suite of 17 (or more) indicators are typically considered in an assessment. The ecological site(s) representative of an assessment location must be known prior to applying the protocol and must be verified based on soils and climate. Current plant community cannot be used to identify the ecological site.

Author(s)/participant(s)	Siddoway/Bandy
Contact for lead author	Great Falls Area Office, Great Falls, MT
	Reference site used? No



Date	04/19/2005
Approved by	Kirt Walstad
Approval date	
Composition (Indicators 10 and 12) based on	Annual Production

## Indicators

1. **Number and extent of rills:** Slopes most common on this site are between 0 – 8% and with at least 95% of the soil surface well-covered there are no rills even with the most extreme convection storms. Rills would be rare on slopes of 9 – 15%.  

---
2. **Presence of water flow patterns:** Due to the soil surface being well covered and minimal slope there is no evidence of past or current soil deposition or erosion for this site on slopes of <6% - may be small areas with patterns on slopes >6%.  

---
3. **Number and height of erosional pedestals or terracettes:** Wind and water erosion will not be evident on this site, so pedestals and terracettes will not be present.  

---
4. **Bare ground from Ecological Site Description or other studies (rock, litter, lichen, moss, plant canopy are not bare ground):** Bare ground should be 5% or less on this site.  

---
5. **Number of gullies and erosion associated with gullies:** Gully erosion will not be evident on this site.  

---
6. **Extent of wind scoured, blowouts and/or depositional areas:** Appearance or evidence of these erosional features on the landscape would not be present on this site.  

---
7. **Amount of litter movement (describe size and distance expected to travel):** Because the site is dominated by the taller bunchgrasses, litter size will reflect the height and diameter of the reproductive culms and leaves of these grasses as well as the lesser dominate mid-size grasses.  

---
8. **Soil surface (top few mm) resistance to erosion (stability values are averages - most sites will show a range of values):** Resistance to erosion will be high with soil stability values of 5 or 6; areas of bare soil on this site may have values less than 5 if not under plant canopy.  

---
9. **Soil surface structure and SOM content (include type of structure and A-horizon color and thickness):** Soil surface structure is granular; A horizon depth is 3 – 5".  

---
10. **Effect of community phase composition (relative proportion of different functional groups) and spatial distribution on infiltration and runoff:** Dominance of taller, deep rooted bunchgrasses will maximize infiltration and

minimize runoff throughout the site.

---

11. **Presence and thickness of compaction layer (usually none; describe soil profile features which may be mistaken for compaction on this site):** Will not be present generally, but there may be areas that have "healed" from former bison trails and wallows which could have a compaction layer below the soil surface.
- 

12. **Functional/Structural Groups (list in order of descending dominance by above-ground annual-production or live foliar cover using symbols: >>, >, = to indicate much greater than, greater than, and equal to):**

Dominant:

Sub-dominant:

Other:

Additional: Cool season, taller grasses (Green needlegrass, Bluebunch wheatgrass) > cool season rhizomatous grasses (Western wheatgrasses (Prairie junegrass) > warm season shortgrass (Blue grama) = shrubs.

---

13. **Amount of plant mortality and decadence (include which functional groups are expected to show mortality or decadence):** Will be low for all functional groups in a given year. Prolonged droughts which last more than 3 years may show increases in mortality and decadence for all plant groups.
- 

14. **Average percent litter cover (%) and depth ( in):**
- 

15. **Expected annual annual-production (this is TOTAL above-ground annual-production, not just forage annual-production):** 1000 - 1600 #/acre. This would be the expected production for the reference state during adequate moisture years. 1300pounds would be the expected production in a 12 inch precipitation zone.
- 

16. **Potential invasive (including noxious) species (native and non-native). List species which BOTH characterize degraded states and have the potential to become a dominant or co-dominant species on the ecological site if their future establishment and growth is not actively controlled by management interventions. Species that become dominant for only one to several years (e.g., short-term response to drought or wildfire) are not invasive plants. Note that unlike other indicators, we are describing what is NOT expected in the reference state for the ecological site:** Blue grama, Japanese brome, a variety of annual or biennial weedy forbs, fringed sagewort, broom snakeweed, prickly pear cactus, cheatgrass
- 

17. **Perennial plant reproductive capability:** During adequate moisture years bunchgrasses will generally produce seeds, however the cool season rhizomatous grasses may not necessarily produce seed even with adequate moisture.
-