

Ecological site R053BY006ND

Saline Lowland

Last updated: 1/11/2024
 Accessed: 05/21/2024

General information

Provisional. A provisional ecological site description has undergone quality control and quality assurance review. It contains a working state and transition model and enough information to identify the ecological site.

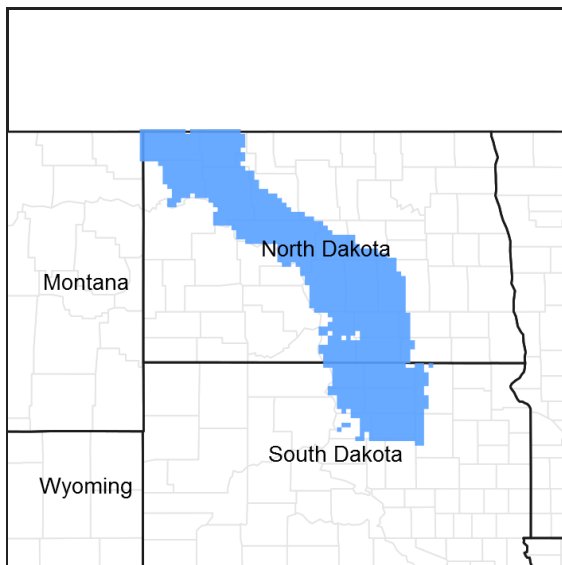

Figure 1. Mapped extent

Areas shown in blue indicate the maximum mapped extent of this ecological site. Other ecological sites likely occur within the highlighted areas. It is also possible for this ecological site to occur outside of highlighted areas if detailed soil survey has not been completed or recently updated.

Classification relationships

Level IV Ecoregions of the Conterminous United States: 42a – Missouri Coteau; 42b – Collapsed Glacial Outwash; 42c – Missouri Coteau Slope; 42d – Northern Missouri Coteau; 42f – Southern Missouri Coteau Slope; 42g – Ponca Plains; and 42h – Southern River Breaks.

Associated sites

R053BY002ND	Claypan
R053BY012ND	Subirrigated
R053BY013ND	Thin Claypan
R053BY018ND	Linear Meadow
R053BY019ND	Wet Meadow

Similar sites

R053BY003ND	<p>Closed Depression [Poorly drained clayey soils with sodic subsoils and with noticeable redoximorphic features within depressions. Ponds periodically with no apparent water table. Indicator species: dominated by western wheatgrass with alkaligrass and foxtail barley intermixed, forb indicator is western dock, no shrubs. This site has more western wheatgrass, more dock and smartweed, slightly higher production, no water table, and a sodic restrictive layer.]</p>
R053BY019ND	<p>Wet Meadow [Poorly drained soils found adjacent to streams or in depressions, with water table at the surface or within 1.5 feet from the surface with no evidence of salts, noticeable redoximorphic features within 6 inches or just below the organic soil layer. Found upslope from Wetlands and downslope of Subirrigated or Loamy Overflow sites; can be located within the listed associated sites. Indicator species are prairie cordgrass and northern reedgrass. This site has more production, less western wheatgrass and more prairie cordgrass, and a water table without a restrictive sodic layer or evidence of salts within the profile.]</p>

Table 1. Dominant plant species

Tree	Not specified
Shrub	Not specified
Herbaceous	(1) <i>Pascopyrum smithii</i> (2) <i>Puccinellia nuttalliana</i>

Physiographic features

This site occurs on nearly level to gently undulating swales, drainageways and flood plains on uplands.

Table 2. Representative physiographic features

Landforms	(1) Till plain (2) Lake plain (3) Flood plain
Flooding duration	Long (7 to 30 days)
Flooding frequency	None to frequent
Ponding frequency	None
Elevation	488–610 m
Slope	0–3%
Ponding depth	0 cm
Water table depth	0–203 cm
Aspect	Aspect is not a significant factor

Climatic features

MLRA 53B is considered to have a continental climate – cold winters and hot summers, low humidity, light rainfall, and much sunshine. Extremes in temperature are characteristic. The climate is the result of this MLRA's location in the geographic center of North America. There are few natural barriers on the northern Great Plains. The air masses move unobstructed across the plains and account for rapid changes in temperature.

Annual precipitation ranges from 15 to 20 inches per year. The normal average annual temperature is about 41° F. January is the coldest month with average temperatures ranging from about 4° F (Powers Lake, ND) to about 10° F (Pollock, SD). July is the warmest month with temperatures averaging from about 67° F (Powers Lake, ND) to about 72° F (Pollock, SD). The range of normal average monthly temperatures between the coldest and warmest months is about 62° F. This large annual range attests to the continental nature of this MLRA's climate. Winds average about 11 miles per hour annually, ranging from about 13 miles per hour during the spring to about 10 miles per hour during the summer. Daytime winds are generally stronger than nighttime and occasional strong storms may bring brief periods of high winds with gusts to more than 50 miles per hour.

Growth of native cool-season plants begins in late March and continues to early to mid July. Native warm-season plants begin growth in mid May and continue to the end of August. Green up of cool-season plants can occur in September and October when adequate soil moisture is present.

Table 3. Representative climatic features

Frost-free period (average)	142 days
Freeze-free period (average)	122 days
Precipitation total (average)	457 mm

Influencing water features

Stream Type: DA6
(Rosgen System)

Soil features

These are moderately deep to very deep, poorly to moderately well drained, coarse to fine textured soils. Saturated hydraulic conductivity is moderate to very slow and available water capacity is low to high. Salinity is moderate, especially in surface layers and sodicity is none to high. Natraquolls are included in this site. This ecological site receives additional moisture from ground water seepage and/or run-on. This site occurs on depressed areas on flood plains, lake plains and till plains. Slope ranges from 0 to 3 percent. Rills and gullies should not typically be present. Water flow patterns should be barely distinguishable if at all present. Pedestals are only slightly present in association with bunchgrasses such as Nuttall's alkaligrass and slender wheatgrass. Litter typically falls in place, and signs of movement are not common. Chemical and physical crusts are common. Cryptogamic crusts occasionally occur on the soil surface. Typically, the interpretive plant community will have good cover of perennial grasses and limited areas of bare ground and infrequent salt crusts.

These soils are susceptible to wind and water erosion. The hazard of water erosion increases on areas that lack vegetative cover. Stream channels are intact with occasional water pockets scattered throughout. Loss of the soil surface can result in a shift in species composition and/or production.

Major soil series correlated to this ecological site can be found in Section II of the Natural Resources Conservation Service Field Office Technical Guide or the following web sites:
<http://www.nrcs.usda.gov/technical/efotg/>

Table 4. Representative soil features

Surface texture	(1) Loam (2) Silt loam (3) Silty clay loam
Family particle size	(1) Loamy
Drainage class	Poorly drained to moderately well drained
Permeability class	Very slow to moderate
Soil depth	51–203 cm
Surface fragment cover <=3"	0–10%
Surface fragment cover >3"	0–5%
Available water capacity (0-101.6cm)	7.62–12.7 cm
Calcium carbonate equivalent (0-101.6cm)	0–45%
Electrical conductivity (0-101.6cm)	0–32 mmhos/cm

Sodium adsorption ratio (0-101.6cm)	0-25
Soil reaction (1:1 water) (0-101.6cm)	6.6-9
Subsurface fragment volume <=3" (Depth not specified)	0-20%
Subsurface fragment volume >3" (Depth not specified)	0-5%

Ecological dynamics

The site developed under Northern Great Plains climatic conditions, and included natural influence of large herbivores and occasional fire. Changes will occur in the plant communities due to climatic conditions and/or management actions. Due to the nature of the soils, the site is considered quite fragile. Under continued adverse impacts, a rapid decline in vegetative vigor and composition will occur. Under favorable vegetative management treatments the site can slowly return to the Historic Climax Plant Community (HCPC).

The plant community upon which interpretations are primarily based is the Historic Climax Plant Community. The HCPC has been determined by study of rangeland relic areas, areas protected from excessive disturbance, and areas under long-term rotational grazing regimes. Trends in plant community dynamics ranging from heavily grazed to lightly grazed areas, seasonal use pastures, and historical accounts also have been considered. Subclimax plant communities, states, transitional pathways, and thresholds have been determined through similar studies and experience.

Continuous grazing without adequate recovery periods following each grazing occurrence causes this site to depart from the HCPC. Species such as western wheatgrass and inland saltgrass will initially increase. Alkali cordgrass and Nuttall's alkaligrass will decrease in frequency and production. Heavy continuous grazing causes foxtail barley, inland saltgrass, mat muhly and unpalatable forbs such as silverweed cinquefoil and dock species to increase and western wheatgrass to decrease. Inland saltgrass can eventually form into a patchy sod and bare ground will typically increase around the sod patches. Increased surface salts are common due to loss of plant cover.

Excessive rest or non-use and lack of fire will result in a plant community having high litter levels with low plant density with an increase in Nuttall's alkaligrass.

The following is a diagram that illustrates the common plant communities that can occur on the site and the transition pathways between communities. The ecological processes will be discussed in more detail in the plant community descriptions following the diagram.

State and transition model

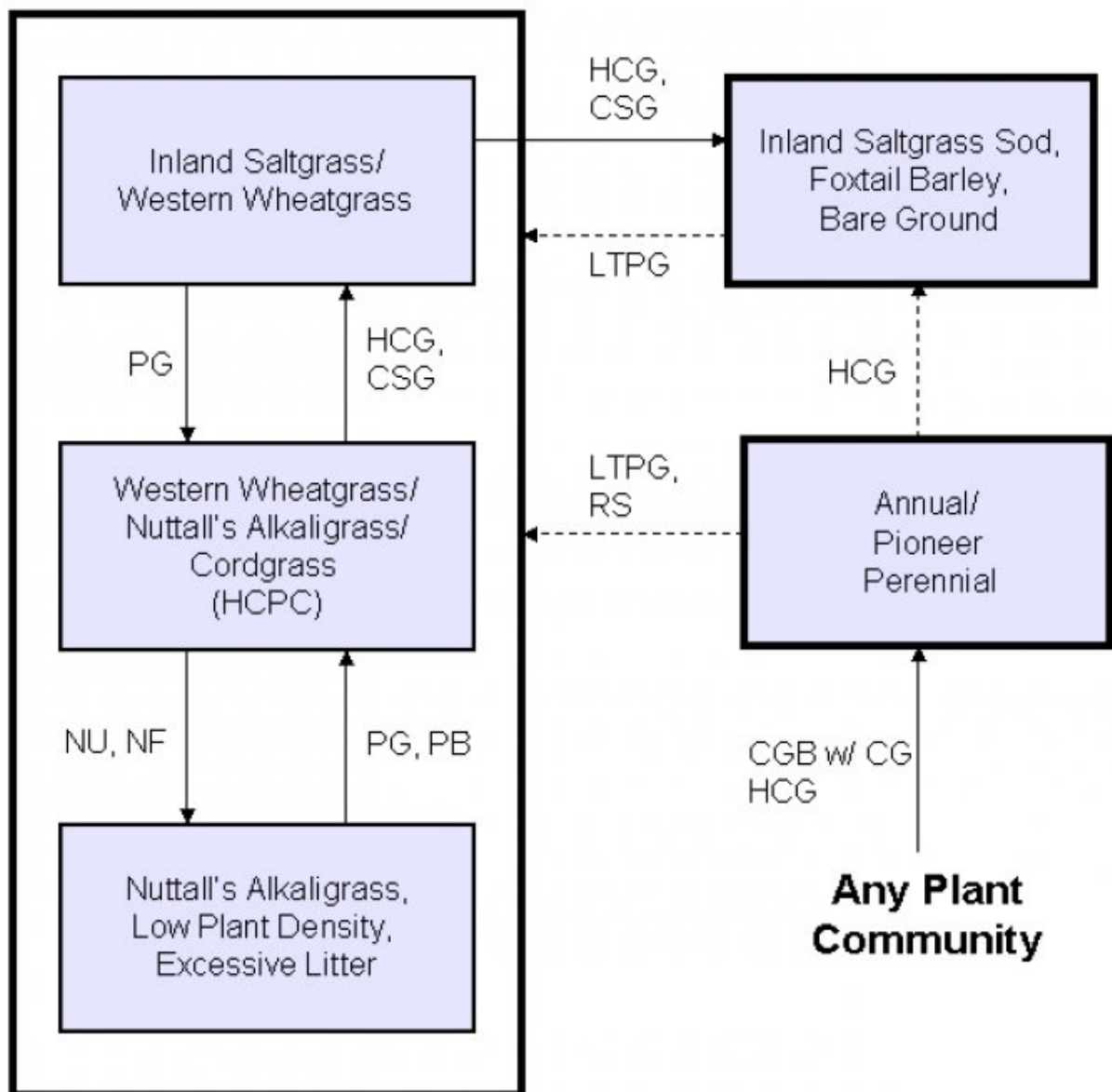

CGB w/ CG – Cropped go-back with continuous grazing; **CSG** – Continuous seasonal grazing, **HCG** – Heavy continuous grazing; **HCPC** – Historic Climax Plant Community; **LTPG** – Long-term prescribed grazing; **NU, NF** – Non-use, no-fire; **PB** – Prescribed burning followed by prescribed grazing; **PG** – Prescribed grazing with adequate recovery opportunity; **RD** – Removal of disturbance; **RS** – Range seeding with prescribed grazing.

State 1

Western Wheatgrass/Nuttall's Alkaligrass/Cordgrass (HCPC)

Community 1.1

Western Wheatgrass/Nuttall's Alkaligrass/Cordgrass (HCPC)

This is the interpretive plant community and is considered to be the Historic Climax Plant Community (HCPC). This community evolved with grazing by large herbivores, occasional prairie fires and periodic flooding events and can be found on areas that are properly managed with grazing and/or prescribed burning, and sometimes on areas receiving occasional short periods of rest. The potential vegetation is about 90% grasses and grass-like plants, 5% forbs and 5% shrubs. The major grasses include western wheatgrass, Nuttall's alkaligrass and alkali and prairie cordgrass. Other grasses present include slender wheatgrass, inland saltgrass and foxtail barley. Salt tolerant forbs such as alkali plantain, western dock and seepweed are common. The shrub that may occur on this site is Nuttall's saltbush. This plant community is diverse, stable, productive and well adapted to both saline soils and the Northern Great Plains climatic conditions. Community dynamics, nutrient cycle, water cycle and energy flow are functioning properly. Litter is properly distributed with very little movement off-site and natural plant mortality is very low. This community is resistant to many disturbances except continuous grazing, tillage and/or development into urban or other uses. The diversity in plant species allows for both the fluctuation of flooding as well as large variations in climate.

Table 5. Annual production by plant type

Plant Type	Low (Kg/Hectare)	Representative Value (Kg/Hectare)	High (Kg/Hectare)
Grass/Grasslike	3032	3570	4102
Moss	73	137	202
Shrub/Vine	–	99	202
Forb	34	118	202
Total	3139	3924	4708

Figure 7. Plant community growth curve (percent production by month).
ND5308, Missouri Coteau, lowland cool-season/warm-season co-dominant..
Cool-season, warm-season co-dominant, lowland..

Jan	Feb	Mar	Apr	May	Jun	Jul	Aug	Sep	Oct	Nov	Dec
0	0	0	3	35	35	15	5	5	2	0	0

State 2

Inland Saltgrass/Western Wheatgrass

Community 2.1

Inland Saltgrass/Western Wheatgrass

This community develops with short-term heavy use, longer term continuous grazing with lack of adequate recovery periods during the growing season, and/or annual, early spring seasonal grazing. Lack of litter and reduced plant heights result in higher soil temperatures, poor water infiltration rates, high evapotranspiration and increased percolation of the high water table, which increases salt concentrations on the surface. This gives inland saltgrass and other salt tolerant species a competitive advantage over less tolerant species. Nuttall's alkaligrass, slender wheatgrass, alkali cordgrass have decreased while western wheatgrass and inland saltgrass will initially increase in composition. Mat muhly, foxtail barley, silverleaf cinquefoil, dock and plantain will also increase in composition. As long as the herbaceous component remains intact, the plant community tends to be resilient. However, species composition can be further altered through long-term heavy continuous grazing. With loss of Nuttall alkaligrass, cordgrasses, slender wheatgrass and much of the western wheatgrass, inland saltgrass becomes the dominant species. This plant community is relatively stable and well adapted to increased salinity. Plant vigor, litter, plant density and production have decreased. The biological integrity, water and nutrient cycles of this plant community are becoming impaired.

Table 6. Annual production by plant type

Plant Type	Low (Kg/Hectare)	Representative Value (Kg/Hectare)	High (Kg/Hectare)
Grass/Grasslike	1631	2096	2556
Moss	118	185	252
Forb	45	148	252
Shrub/Vine	–	37	78
Total	1794	2466	3138

Figure 9. Plant community growth curve (percent production by month). ND5309, Missouri Coteau, warm-season dominant, cool-season sub-dominant.. Warm-season dominant, cool-season sub-dominant, lowland..

Jan	Feb	Mar	Apr	May	Jun	Jul	Aug	Sep	Oct	Nov	Dec
0	0	0	2	32	33	20	7	4	2	0	0

State 3 Nuttall's Alkaligrass, Low Plant Density, Excessive Litter

Community 3.1 Nuttall's Alkaligrass, Low Plant Density, Excessive Litter

This plant community occurs when grazing is removed for long periods of time (rest) in the absence of fire. Plant composition is similar to the HCPC, however individual species production and frequency will be lower. Much of the nutrients are tied up in excessive litter. Standing dead plant residues that are not in contact with a moist soil surface result in a slow nutrient recycling process. Aboveground litter also limits sunlight from reaching plant crowns. Tall warm-season grasses (cordgrasses) die off or reduce in density and vigor and typically develop into small but dense colonies. Thick litter and absence of grazing animals (animal impact) or fire reduces seed germination and establishment. This plant community develops after an extended period of 10 or more years of non-use by herbivores and exclusion of fire. This plant community is resistant to change without prescribed grazing or fire. The combination of both grazing and fire is most effective in moving this plant community towards the HCPC. Soil erosion is low. Runoff is similar to the HCPC. Once this plant community is reached, time and external resources will be needed to see any immediate recovery in diversity.

Table 7. Annual production by plant type

Plant Type	Low (Kg/Hectare)	Representative Value (Kg/Hectare)	High (Kg/Hectare)
Grass/Grasslike	1922	2340	2735
Forb	135	280	448
Moss	50	99	146
Shrub/Vine	22	83	146
Total	2129	2802	3475

Figure 11. Plant community growth curve (percent production by month). ND5306, Missouri Coteau, lowland cool-season dominant.. Cool-season dominant, lowland..

Jan	Feb	Mar	Apr	May	Jun	Jul	Aug	Sep	Oct	Nov	Dec
0	0	3	10	37	35	5	2	8	0	0	0

State 4 Inland Saltgrass Sod, Foxtail Barley, Bare Ground

Community 4.1 Inland Saltgrass Sod, Foxtail Barley, Bare Ground

This plant community developed with heavy continuous grazing where adequate recovery periods between grazing events were not allowed. Patches of inland saltgrass sod are typical and foxtail barley is well distributed throughout the community. Nuttall's alkaligrass and western wheatgrass have been greatly reduced and may persist in remnant amounts, reduced in vigor. Bare ground may develop in micro lows where salt concentrations are highest. A white salt crust is common on the surface. Only a few very salt tolerant annuals, such as glasswort and seepweed, can survive. This plant community is resistant to change due to the grazing tolerance of inland saltgrass and increased surface salts. A significant amount of production and diversity has been lost when compared to the HCPC. Loss of key cool-season grasses and increased bare ground has negatively impacted energy flow and nutrient cycling. Water infiltration is reduced significantly due to the massive shallow root system "root pan", characteristic of inland saltgrass, and increased bare ground. It will take a long time to bring this plant community back to the HCPC with management alone. Renovation (mechanical and/or chemical inputs) is not recommended due to high salt content of the soil and saltgrass persistence.

Table 8. Annual production by plant type

Plant Type	Low (Kg/Hectare)	Representative Value (Kg/Hectare)	High (Kg/Hectare)
Grass/Grasslike	857	1420	1978
Forb	28	94	163
Moss	11	47	84
Shrub/Vine	–	8	17
Total	896	1569	2242

Figure 13. Plant community growth curve (percent production by month).
ND5309, Missouri Coteau, warm-season dominant, cool-season sub-
dominant.. Warm-season dominant, cool-season sub-dominant, lowland..

Jan	Feb	Mar	Apr	May	Jun	Jul	Aug	Sep	Oct	Nov	Dec
0	0	0	2	32	33	20	7	4	2	0	0

Additional community tables

Table 9. Community 1.1 plant community composition

Group	Common Name	Symbol	Scientific Name	Annual Production (Kg/Hectare)	Foliar Cover (%)
Grass/Grasslike					
1	Wheatgrass			588–981	
	western wheatgrass	PASM	<i>Pascopyrum smithii</i>	588–981	–
2	Alkaligrass			588–981	
	Nuttall's alkaligrass	PUNU2	<i>Puccinellia nuttalliana</i>	588–981	–
3	Cordgrass			392–785	
	alkali cordgrass	SPGR	<i>Spartina gracilis</i>	392–785	–
	prairie cordgrass	SPPE	<i>Spartina pectinata</i>	392–785	–
4	Other Native Perennial			196–588	
	saltgrass	DISP	<i>Distichlis spicata</i>	78–392	–
	slender wheatgrass	ELTR7	<i>Elymus trachycaulus</i>	0–196	–
	Grass, perennial	2GP	<i>Grass, perennial</i>	39–196	–
	plains bluegrass	POAR3	<i>Poa arida</i>	39–118	–
	fowl bluegrass	POPA2	<i>Poa palustris</i>	0–78	–
	little bluestem	SCSC	<i>Schizachyrium scoparium</i>	0–78	–
	foxtail barley	HOJU	<i>Hordeum jubatum</i>	0–78	–
	scratchgrass	MUAS	<i>Muhlenbergia asperifolia</i>	39–78	–
	mat muhly	MURI	<i>Muhlenbergia richardsonis</i>	39–78	–
6	Grass-Likes			78–196	
	sedge	CAREX	<i>Carex</i>	39–196	–
	rush	JUNCU	<i>Juncus</i>	39–118	–
	Grass-like (not a true grass)	2GL	<i>Grass-like (not a true grass)</i>	0–118	–
Forb					
7	Forbs			39–196	
	Forb, perennial	2FP	<i>Forb, perennial</i>	39–118	–
	western dock	RUAQ	<i>Rumex aquaticus</i>	39–118	–
	silver cinquefoil	POAR8	<i>Potentilla argentea</i>	39–78	–
	silverscale saltbush	ATAR2	<i>Atriplex argentea</i>	39–78	–
	povertyweed	IVAX	<i>Iva axillaris</i>	0–39	–
	redwool plantain	PLER	<i>Plantago eriopoda</i>	0–39	–
	little hogweed	POOL	<i>Portulaca oleracea</i>	0–39	–
	seepweed	SUAED	<i>Suaeda</i>	0–39	–
	Pursh seepweed	SUCA2	<i>Suaeda calceoliformis</i>	0–39	–
Shrub/Vine					
8	Shrubs			0–196	
	Nuttall's saltbush	ATNU2	<i>Atriplex nuttallii</i>	0–196	–
	Subshrub (<.5m)	2SUBS	<i>Subshrub (<.5m)</i>	0–78	–

Table 10. Community 2.1 plant community composition

Group	Common Name	Symbol	Scientific Name	Annual Production (Kg/Hectare)	Foliar Cover (%)
Grass/Grasslike					
1	Wheatgrass			493–986	
	western wheatgrass	PASM	<i>Pascopyrum smithii</i>	493–986	–
2	Alkaligrass			25–99	
	Nuttall's alkaligrass	PUNU2	<i>Puccinellia nuttalliana</i>	25–99	–
3	Cordgrass			0–25	
	alkali cordgrass	SPGR	<i>Spartina gracilis</i>	0–25	–
	prairie cordgrass	SPPE	<i>Spartina pectinata</i>	0–25	–
4	Other Native Perennial			370–740	
	saltgrass	DISP	<i>Distichlis spicata</i>	247–493	–
	foxtail barley	HOJU	<i>Hordeum jubatum</i>	49–247	–
	fowl bluegrass	POPA2	<i>Poa palustris</i>	49–247	–
	mat muhly	MURI	<i>Muhlenbergia richardsonis</i>	25–123	–
	Grass, perennial	2GP	<i>Grass, perennial</i>	0–123	–
	plains bluegrass	POAR3	<i>Poa arida</i>	25–74	–
5	Non-Native Grasses			0–49	
	Graminoid (grass or grass-like)	2GRAM	<i>Graminoid (grass or grass-like)</i>	0–49	–
	Kentucky bluegrass	POPR	<i>Poa pratensis</i>	0–49	–
6	Grass-Likes			123–247	
	Grass-like (not a true grass)	2GL	<i>Grass-like (not a true grass)</i>	0–123	–
	sedge	CAREX	<i>Carex</i>	25–123	–
	rush	JUNCU	<i>Juncus</i>	25–123	–
Forb					
7	Forbs			49–247	
	curly dock	RUCR	<i>Rumex crispus</i>	49–197	–
	Forb, annual	2FA	<i>Forb, annual</i>	0–99	–
	Forb, perennial	2FP	<i>Forb, perennial</i>	0–99	–
	povertyweed	IVAX	<i>Iva axillaris</i>	25–74	–
	pepperweed	LEPID	<i>Lepidium</i>	0–49	–
	lambsquarters	CHAL7	<i>Chenopodium album</i>	0–49	–
	curlycup gumweed	GRSQ	<i>Grindelia squarrosa</i>	0–49	–
	seepweed	SUAED	<i>Suaeda</i>	0–49	–
	cocklebur	XANTH2	<i>Xanthium</i>	0–49	–
	little hogweed	POOL	<i>Portulaca oleracea</i>	0–49	–
	western dock	RUAQ	<i>Rumex aquaticus</i>	0–49	–
	redwool plantain	PLER	<i>Plantago eriopoda</i>	0–25	–
	silver cinquefoil	POAR8	<i>Potentilla argentea</i>	0–25	–
Shrub/Vine					
8	Shrubs			0–74	
	Subshrub (<.5m)	2SUBS	<i>Subshrub (<.5m)</i>	0–74	–
	Nuttall's saltbush	ATNU2	<i>Atriplex nuttallii</i>	0–74	–

Table 11. Community 3.1 plant community composition

Group	Common Name	Symbol	Scientific Name	Annual Production (Kg/Hectare)	Foliar Cover (%)
Grass/Grasslike					
1	Wheatgrass			280–560	
	western wheatgrass	PASM	<i>Pascopyrum smithii</i>	280–560	–
2	Alkaligrass			140–280	
	Nuttall's alkaligrass	PUNU2	<i>Puccinellia nuttalliana</i>	140–280	–
3	Cordgrass			56–280	
	alkali cordgrass	SPGR	<i>Spartina gracilis</i>	56–280	–
	prairie cordgrass	SPPE	<i>Spartina pectinata</i>	56–280	–
4	Other Native Perennial			420–701	
	foxtail barley	HOJU	<i>Hordeum jubatum</i>	140–280	–
	plains bluegrass	POAR3	<i>Poa arida</i>	140–280	–
	fowl bluegrass	POPA2	<i>Poa palustris</i>	140–280	–
	saltgrass	DISP	<i>Distichlis spicata</i>	28–140	–
	mat muhly	MURI	<i>Muhlenbergia richardsonis</i>	28–112	–
	Grass, perennial	2GP	<i>Grass, perennial</i>	0–112	–
	scratchgrass	MUAS	<i>Muhlenbergia asperifolia</i>	28–84	–
	slender wheatgrass	ELTR7	<i>Elymus trachycaulus</i>	0–84	–
5	Non-Native Grasses			56–280	
	Kentucky bluegrass	POPR	<i>Poa pratensis</i>	56–280	–
	Graminoid (grass or grass-like)	2GRAM	<i>Graminoid (grass or grass-like)</i>	0–140	–
6	Grass-Likes			56–140	
	sedge	CAREX	<i>Carex</i>	28–112	–
	rush	JUNCU	<i>Juncus</i>	28–84	–
	Grass-like (not a true grass)	2GL	<i>Grass-like (not a true grass)</i>	0–84	–
Forb					
7	Forbs			140–420	
	curly dock	RUCR	<i>Rumex crispus</i>	56–280	–
	Forb, annual	2FA	<i>Forb, annual</i>	0–140	–
	Forb, perennial	2FP	<i>Forb, perennial</i>	0–140	–
	lambsquarters	CHAL7	<i>Chenopodium album</i>	28–112	–
	western dock	RUAQ	<i>Rumex aquaticus</i>	28–112	–
	silver cinquefoil	POAR8	<i>Potentilla argentea</i>	28–84	–
	little hogweed	POOL	<i>Portulaca oleracea</i>	0–56	–
	povertyweed	IVAX	<i>Iva axillaris</i>	0–56	–
	pepperweed	LEPID	<i>Lepidium</i>	0–56	–
	seepweed	SUAED	<i>Suaeda</i>	0–56	–
	Pursh seepweed	SUCA2	<i>Suaeda calceoliformis</i>	0–56	–
	cocklebur	XANTH2	<i>Xanthium</i>	0–56	–
	redwool plantain	PLER	<i>Plantago eriopoda</i>	0–28	–
	curlycup gumweed	GRSQ	<i>Grindelia squarrosa</i>	0–28	–

Shrub/Vine					
8	Shrubs			28–140	
	Nuttall's saltbush	ATNU2	<i>Atriplex nuttallii</i>	28–140	–
	Subshrub (<.5m)	2SUBS	<i>Subshrub (<.5m)</i>	0–112	–

Table 12. Community 4.1 plant community composition

Group	Common Name	Symbol	Scientific Name	Annual Production (Kg/Hectare)	Foliar Cover (%)
Grass/Grasslike					
1	Wheatgrass			31–157	
	western wheatgrass	PASM	<i>Pascopyrum smithii</i>	31–157	–
2	Alkaligrass			0–78	
	Nuttall's alkaligrass	PUNU2	<i>Puccinellia nuttalliana</i>	0–78	–
4	Other Native Perennial			471–1020	
	saltgrass	DISP	<i>Distichlis spicata</i>	235–706	–
	foxtail barley	HOJU	<i>Hordeum jubatum</i>	235–706	–
	mat muhly	MURI	<i>Muhlenbergia richardsonis</i>	16–78	–
	fowl bluegrass	POPA2	<i>Poa palustris</i>	16–78	–
	plains bluegrass	POAR3	<i>Poa arida</i>	0–31	–
5	Non-Native Grasses			0–63	
	Graminoid (grass or grass-like)	2GRAM	<i>Graminoid (grass or grass-like)</i>	0–63	–
6	Grass-Likes			16–78	
	rush	JUNCU	<i>Juncus</i>	16–63	–
	Grass-like (not a true grass)	2GL	<i>Grass-like (not a true grass)</i>	0–47	–
	sedge	CAREX	<i>Carex</i>	0–47	–
Forb					
7	Forbs			31–157	
	curly dock	RUCR	<i>Rumex crispus</i>	0–78	–
	Forb, annual	2FA	<i>Forb, annual</i>	0–63	–
	Forb, perennial	2FP	<i>Forb, perennial</i>	0–63	–
	pepperweed	LEPID	<i>Lepidium</i>	16–63	–
	little hogweed	POOL	<i>Portulaca oleracea</i>	16–47	–
	lambsquarters	CHAL7	<i>Chenopodium album</i>	16–47	–
	curlycup gumweed	GRSQ	<i>Grindelia squarrosa</i>	0–47	–
	povertyweed	IVAX	<i>Iva axillaris</i>	16–47	–
	seepweed	SUAED	<i>Suaeda</i>	16–47	–
	cocklebur	XANTH2	<i>Xanthium</i>	0–31	–
	western dock	RUAQ	<i>Rumex aquaticus</i>	0–31	–
	silver cinquefoil	POAR8	<i>Potentilla argentea</i>	0–16	–
Shrub/Vine					
8	Shrubs			0–16	
	Subshrub (<.5m)	2SUBS	<i>Subshrub (<.5m)</i>	0–16	–
	Nuttall's saltbush	ATNU2	<i>Atriplex nuttallii</i>	0–16	–

Animal community

Wildlife Interpretations:
Under development.

Grazing Interpretations:

This site is well adapted to managed grazing by domestic livestock. The predominance of herbaceous plants across all plant community phases best lends these sites to grazing by cattle but other domestic grazers with differing diet preferences may also be a consideration depending upon management objectives. Often, the current plant community does not entirely match any particular plant community (as described in the ecological site description). Because of this, a resource inventory is necessary to document plant composition and production. Proper interpretation of this inventory data will permit the establishment of a safe, initial stocking rate for the type and class of animals and level of grazing management. More accurate stocking rate estimates should eventually be calculated using actual stocking rate information and monitoring data.

Hydrological functions

Available water is the principal factor limiting forage production on this site. Inherent soil salinity indirectly influences the availability of water to plants growing on the site. This site is dominated by soils in hydrologic groups C and D with localized areas in hydrologic group B. Infiltration varies from moderately slow to slow and runoff potential varies from low to moderate depending on soil hydrologic group and ground cover. In many cases, areas with greater than 75% ground cover have the greatest potential for high infiltration and lower runoff. An exception would be where short grasses form a strong sod and dominate the site. Areas where ground cover is less than 50% have the greatest potential to have reduced infiltration and higher runoff (refer to Section 4, NRCS National Engineering Handbook for runoff quantities and hydrologic curves).

Recreational uses

This site offers open space and opportunity for intermittent viewing and/or hunting of a few wildlife species.

Wood products

No appreciable wood products are present on the site.

Other products

Seed harvest of native plant species can provide additional income on this site.

Inventory data references

Information presented here has been derived from NRCS clipping and other inventory data. Also, field knowledge of range-trained personnel was used. All descriptions were peer reviewed and/or field-tested by various private, state and federal agency specialists. Those involved in developing this site description include: Stan Boltz, NRCS Range Management Specialist; Michael D. Brand, State Land Dept., Director Surface Management; David Dewald, NRCS State Biologist; Paul Drayton, NRCS District Conservationist; Jody Forman, NRCS Range Management Specialist; Dennis Froemke, NRCS Range Management Specialist; Jeff Printz, NRCS State Range Management Specialist; Josh Saunders, NRCS Range Management Specialist; Kevin Sedivec, Extension Rangeland Management Specialist; Darrell Vanderbusch, NRCS Resource Soil Scientist; and Lee Voigt, NRCS Range Management Specialist.

Other references

High Plains Regional Climate Center, University of Nebraska, 830728 Chase Hall, Lincoln, NE 68583-0728.
(<http://hprcc.unl.edu>)
USDA, NRCS. National Water and Climate Center, 101 SW Main, Suite 1600, Portland, OR 97204-3224.
(<http://www.wcc.nrcs.usda.gov>)
USDA, NRCS. National Range and Pasture Handbook, September 1997

USDA, NRCS. National Soil Information System, Information Technology Center, 2150 Centre Avenue, Building A, Fort Collins, CO 80526. (<http://nasis.nrcs.usda.gov>)

USDA, NRCS. 2001. The PLANTS Database, Version 3.1 (<http://plants.usda.gov>). National Plant Data Center, Baton Rouge, LA 70874-4490 USA.

USDA, NRCS, Various Published Soil Surveys.

Contributors

Jeff Printz

Jeff Printz/Stan Boltz

Approval

Suzanne Mayne-Kinney, 1/11/2024

Rangeland health reference sheet

Interpreting Indicators of Rangeland Health is a qualitative assessment protocol used to determine ecosystem condition based on benchmark characteristics described in the Reference Sheet. A suite of 17 (or more) indicators are typically considered in an assessment. The ecological site(s) representative of an assessment location must be known prior to applying the protocol and must be verified based on soils and climate. Current plant community cannot be used to identify the ecological site.

Author(s)/participant(s)	Jeff Printz, Stan Boltz, Lee Voigt, Jody Forman
Contact for lead author	Jeff.printz@nd.usda.gov 701-530-2080
Date	01/17/2012
Approved by	Suzanne Mayne-Kinney
Approval date	
Composition (Indicators 10 and 12) based on	Annual Production

Indicators

1. **Number and extent of rills:** None.

2. **Presence of water flow patterns:** None.

3. **Number and height of erosional pedestals or terracettes:** None.

4. **Bare ground from Ecological Site Description or other studies (rock, litter, lichen, moss, plant canopy are not bare ground):** Bare ground is 5% or less with bare patches less than 2 inches in diameter and not connected. Slickspots of varying size can occur in complex with this site and will be mostly bare ground with sparse, salt-tolerant vegetation. Slickspots typically have salt crusting at the surface.

5. **Number of gullies and erosion associated with gullies:** None.

6. **Extent of wind scoured, blowouts and/or depositional areas:** None.

7. **Amount of litter movement (describe size and distance expected to travel):** None.

8. **Soil surface (top few mm) resistance to erosion (stability values are averages - most sites will show a range of values):** Soil aggregate stability should be 5 or greater. Soil surface has high root content and is resistant to erosion.

9. **Soil surface structure and SOM content (include type of structure and A-horizon color and thickness):** Use soil series description for depth, color and structure of A horizon/surface layer.

10. **Effect of community phase composition (relative proportion of different functional groups) and spatial distribution on infiltration and runoff:** High grass canopy and small gaps between plants reduces raindrop impact and slows overland flow, providing increased time for infiltration to occur. Healthy, deep rooted native grasses enhance infiltration and reduce runoff.

11. **Presence and thickness of compaction layer (usually none; describe soil profile features which may be mistaken for compaction on this site):** None. Naturally occurring platy structure may be observable.

12. **Functional/Structural Groups (list in order of descending dominance by above-ground annual-production or live foliar cover using symbols: >>, >, = to indicate much greater than, greater than, and equal to):**

Dominant: Short and mid cool-season bunchgrasses = mid, cool-season rhizomatous

Sub-dominant: Tall and mid warm-season rhizomatous grasses

Other: Short, warm-season grasses > grass-likes = forbs > shrubs

Additional: Due to differing root structure and distribution, Kentucky bluegrass and smooth bromegrass do not fit into reference plant community F/S groups.

13. **Amount of plant mortality and decadence (include which functional groups are expected to show mortality or decadence):** None.

14. **Average percent litter cover (%) and depth (in):** In contact with soil surface.

15. **Expected annual annual-production (this is TOTAL above-ground annual-production, not just forage annual-production):** Representative value = 3500 lbs/ac air dry with a range of 2800 to 4200 lbs./ac air dry depending upon growing conditions.

16. **Potential invasive (including noxious) species (native and non-native).** List species which **BOTH** characterize degraded states and have the potential to become a dominant or co-dominant species on the ecological site if their future establishment and growth is not actively controlled by management interventions. Species that become dominant for only one to several years (e.g., short-term response to drought or wildfire) are not invasive plants. Note that unlike other indicators, we are describing what is **NOT** expected in the reference state for the ecological site: State and local noxious, Kentucky bluegrass, smooth bromegrass, Russian olive
-

17. **Perennial plant reproductive capability:** All species exhibit high vigor relative to climatic conditions. Do not rate based solely on seed production. Perennial grasses should have vigorous rhizomes or tillers.
-