

Ecological site R053BY009ND Shallow Loamy

Last updated: 1/11/2024
Accessed: 09/27/2024

General information

Provisional. A provisional ecological site description has undergone quality control and quality assurance review. It contains a working state and transition model and enough information to identify the ecological site.

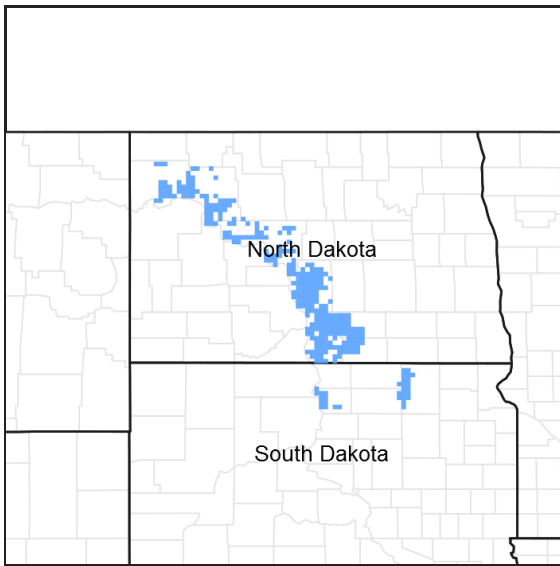

Figure 1. Mapped extent

Areas shown in blue indicate the maximum mapped extent of this ecological site. Other ecological sites likely occur within the highlighted areas. It is also possible for this ecological site to occur outside of highlighted areas if detailed soil survey has not been completed or recently updated.

Classification relationships

Level IV Ecoregions of the Conterminous United States: 42a – Missouri Coteau; 42b – Collapsed Glacial Outwash; 42c – Missouri Coteau Slope; 42d – Northern Missouri Coteau; 42f – Southern Missouri Coteau Slope; 42g – Ponca Plains; and 42h – Southern River Breaks.

Associated sites

R053BY008ND	Sandy
R053BY011ND	Loamy
R053BY015ND	Thin Loamy
R053BY017ND	Very Shallow

Similar sites

R053BY015ND	<p>Thin Loamy [Deep and moderately deep entisols, usually calcareous within 4 inches to the surface, found on knobs and/or sideslopes of hills and buttes. Will form a ribbon greater than 1 inches but not more than 2 inches. Up slope of Loamy site. Indicator species: little bluestem, western wheatgrass, plains muhly, porcupinegrass and sideoats grama, with Missouri goldenrod, dotted gayfeather, pasqueflower, purple coneflower and purple prairie clover, and shrubs like prairie rose. This site has similar species but more little bluestem more production, deeper soils, no restrictive layer above twenty inches.]</p>
R053BY017ND	<p>Very Shallow [Excessively well drained soils less than 10 inches to scoria, gravels, shales, siltstone or sandstone bedrock that restricts root penetration, upslope of Shallow loamy site. Indicator species are blue grama, sideoats grama, purple coneflower, pasqueflower and creeping juniper. This site has similar species but more needleandthread, blue grama and less plains muhly, green needlegrass, western wheatgrass, restrictive layer above 10 inches is scoria or gravels, less production.]</p>

Table 1. Dominant plant species

Tree	Not specified
Shrub	Not specified
Herbaceous	(1) <i>Nassella viridula</i> (2) <i>Hesperostipa spartea</i>

Physiographic features

This site typically occurs on moderately sloping to very steep uplands.

Table 2. Representative physiographic features

Landforms	(1) Hill (2) Escarpment (3) Ridge
Flooding frequency	None
Ponding frequency	None
Elevation	488–610 m
Slope	6–60%
Aspect	Aspect is not a significant factor

Climatic features

MLRA 53B is considered to have a continental climate – cold winters and hot summers, low humidity, light rainfall, and much sunshine. Extremes in temperature are characteristic. The climate is the result of this MLRA's location in the geographic center of North America. There are few natural barriers on the northern Great Plains. The air masses move unobstructed across the plains and account for rapid changes in temperature.

Annual precipitation ranges from 15 to 20 inches per year. The normal average annual temperature is about 41° F. January is the coldest month with average temperatures ranging from about 4° F (Powers Lake, ND) to about 10° F (Pollock, SD). July is the warmest month with temperatures averaging from about 67° F (Powers Lake, ND) to about 72° F (Pollock, SD). The range of normal average monthly temperatures between the coldest and warmest months is about 62° F. This large annual range attests to the continental nature of this MLRA's climate. Winds average about 11 miles per hour annually, ranging from about 13 miles per hour during the spring to about 10 miles per hour during the summer. Daytime winds are generally stronger than nighttime and occasional strong storms may bring brief periods of high winds with gusts to more than 50 miles per hour.

Growth of native cool-season plants begins in late March and continues to early to mid July. Native warm-season plants begin growth in mid May and continue to the end of August. Green up of cool-season plants can occur in September and October when adequate soil moisture is present.

Table 3. Representative climatic features

Frost-free period (average)	135 days
Freeze-free period (average)	156 days
Precipitation total (average)	508 mm

Influencing water features

No significant water features influence this site.

Soil features

These are shallow, well drained, medium and moderately fine textured soils overlying weathered mudstone or siltstone at less than 20 inches. Saturated hydraulic conductivity is moderate or moderately slow and available water capacity is low or very low. Salinity and sodicity are none to slight. This site occurs on hills, escarpments and ridges on nearly level to very steep residual uplands. Slope ranges from 6 to 60 percent. This site should show slight to no evidence of rills, wind scoured areas or pedestalled plants. Water flow paths are broken, irregular in appearance or discontinuous. The soil surface is stable and intact.

These soils are mainly susceptible to water erosion. The hazard of water erosion increases on slopes greater than about 15 percent. Low available water capacity coupled with high accumulations of lime and slow permeability strongly influences the soil-water-plant relationship. Loss of the soil surface layer can result in a shift in species composition and/or production.

Major soil series correlated to this ecological site can be found in Section II of the Natural Resources Conservation Service Field Office Technical Guide or the following web sites:

<http://www.nrcs.usda.gov/technical/efotg/>

Table 4. Representative soil features

Surface texture	(1) Loam
Family particle size	(1) Loamy
Drainage class	Well drained
Permeability class	Moderate
Soil depth	25–51 cm
Surface fragment cover <=3"	0–15%
Surface fragment cover >3"	0–5%
Available water capacity (0-101.6cm)	7.62 cm
Calcium carbonate equivalent (0-101.6cm)	0–15%
Electrical conductivity (0-101.6cm)	0–8 mmhos/cm
Sodium adsorption ratio (0-101.6cm)	0
Soil reaction (1:1 water) (0-101.6cm)	6.6–8.4
Subsurface fragment volume <=3" (Depth not specified)	0–15%
Subsurface fragment volume >3" (Depth not specified)	0–5%

Ecological dynamics

The site developed under Northern Great Plains climatic conditions, and included natural influence of large herbivores and occasional fire. Changes will occur in the plant communities due to climatic conditions and/or management actions. Due to the nature of the soils, the site is considered quite fragile. Under continued adverse impacts, a rapid decline in vegetative vigor and composition will occur. Under favorable vegetative management treatments the site can slowly return to the Historic Climax Plant Community (HCPC).

The plant community upon which interpretations are primarily based is the HCPC. The HCPC has been determined by study of rangeland relic areas, areas protected from excessive disturbance, and areas under long-term rotational grazing regimes. Trends in plant community dynamics ranging from heavily grazed to lightly grazed areas, seasonal use pastures, and historical accounts also have been considered. Subclimax plant communities, states, transitional pathways, and thresholds have been determined through similar studies and experience.

Continuous grazing without adequate recovery periods following each grazing occurrence over several years causes this site to depart from the HCPC. Species such as little bluestem, needleandthread, threadleaf sedge and blue grama will initially increase. Porcupine grass, green needlegrass, plains muhly and sideoats grama will decrease in frequency and production. Heavy continuous grazing causes blue grama and/or threadleaf sedge to increase and eventually dominate and pioneer perennials and annuals to increase. The resulting plant community is relatively stable and the competitive advantage prevents other species from establishing.

Under extended periods of non-use and/or lack of fire will result in a plant community having high litter levels, which favors an increase in Kentucky bluegrass and/or smooth brome grass and in time, shrubs such as fringed sagewort and cactus will increase.

The following diagram illustrates the common plant communities and vegetation states commonly occurring on the site and the transition pathways between communities and states. The ecological processes will be discussed in more detail in the plant community descriptions following the diagram.

State and transition model

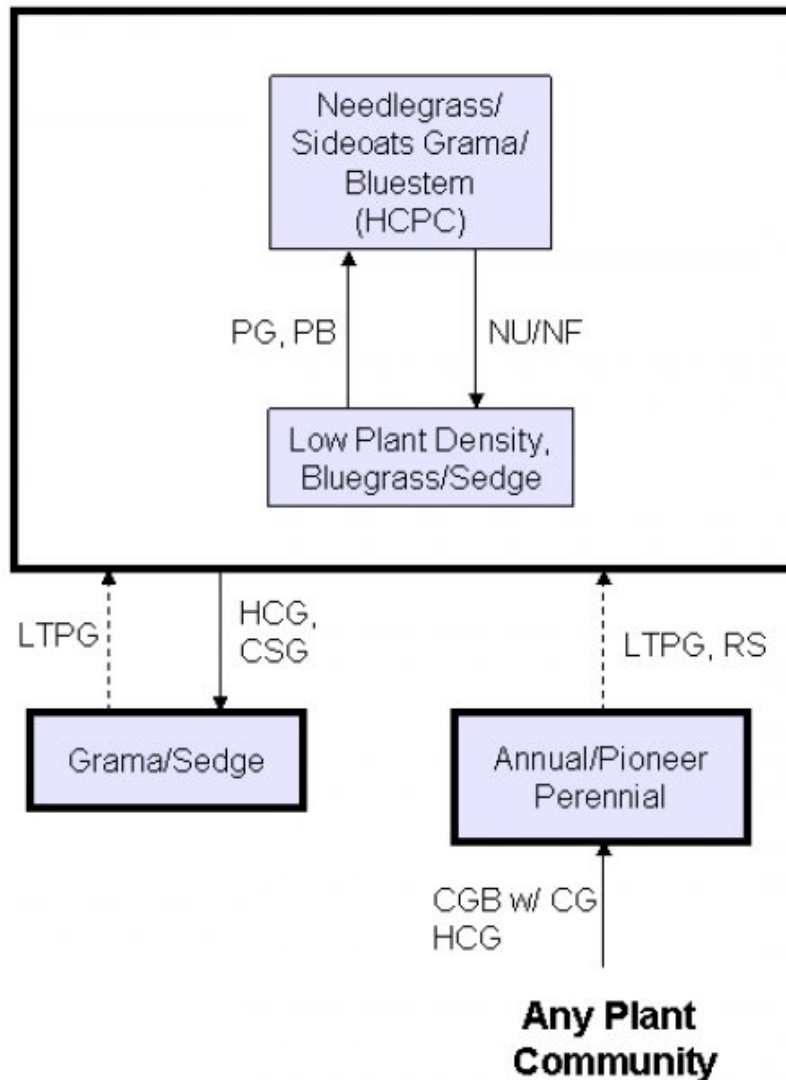

CGB w/ CG – Cropped go-back with continuous grazing; **CSG** – Continuous seasonal grazing; **HCG** – Heavy continuous grazing; **HCPC** – Historical Climax Plant Community; **LTPG** – Long-term prescribed grazing; **NU/NF** – Extended period of non-use & no fire; **PB** – Prescribed burning; **PG** – Prescribed grazing; **RS** – Range seeding followed by prescribed grazing.

State 1
Needlegrass/Sideoats Grama/Bluestem (HCPC)

Community 1.1

Needlegrass/Sideoats Grama/Bluestem (HCPC)

This is the interpretive plant community and is considered to be the Historic Climax Plant Community (HCPC). This community evolved with grazing by large herbivores and occasional prairie fire. It is well suited for grazing by domestic livestock and can be found on areas that are properly managed with prescribed grazing that allows for proper utilization, changes in season of use and adequate recovery periods following each grazing event. The potential vegetation is about 85% grasses or grass-like plants, 10% forbs and 5% shrubs. A mix of cool-season and warm-season grasses dominates this plant community. The major grasses include green needlegrass, porcupine grass, sideoats grama, little bluestem, big bluestem, plains muhly and western wheatgrass. Other grasses occurring on the site include prairie junegrass, red threeawn and blue grama. The significant forbs include gayfeather, purple coneflower, prairie clover and cutleaf ironplant. Significant shrubs may include fringed sagewort, leadplant and rose. This plant community is well adapted to the Northern Great Plains climatic conditions. Individual species can vary greatly in production depending on growing conditions (timing and amount of precipitation and temperature). Community dynamics, nutrient cycle, water cycle and energy flow are functioning properly. Plant litter is properly distributed with very little movement off-site and natural plant mortality is very low. The diversity in plant species allows for high drought tolerance.

Table 5. Annual production by plant type

Plant Type	Low (Kg/Hectare)	Representative Value (Kg/Hectare)	High (Kg/Hectare)
Grass/Grasslike	1519	2195	2869
Forb	118	185	252
Shrub/Vine	45	86	129
Total	1682	2466	3250

Figure 5. Plant community growth curve (percent production by month).
ND5303, Missouri Coteau, cool-season/warm-season co-dominant.. Cool-season, warm-season co-dominant..

Jan	Feb	Mar	Apr	May	Jun	Jul	Aug	Sep	Oct	Nov	Dec
0	0	2	6	21	40	20	6	4	1	0	0

State 2

Grama/Sedge

Community 2.1

Grama/Sedge

This plant community is the result of long-term, heavy, continuous grazing and/or continuous seasonal grazing (annual, early spring seasonal grazing). Annual, grazing too early in the spring depletes stored carbohydrates, resulting in weakening and eventual death of the cool season mid-grasses. Short grasses and forbs increase to dominate and annual production decreases dramatically. Lack of litter and reduced plant vigor result in higher soil temperatures, poor water infiltration rates, and high evapotranspiration, which gives blue grama a competitive advantage over cool season mid-grasses. This plant community can occur throughout the pasture, on spot grazed areas, and around water sources where season-long grazing patterns occur. Blue grama and threadleaf sedge are the dominant grass/grass-like species. Other grasses include western wheatgrass, needleandthread, little bluestem, prairie junegrass and red threeawn. Significant forbs include American pasqueflower, cutleaf ironplant, groundplum milkvetch, prairie coneflower and scarlet globemallow. There is usually less than 10% bare ground. The significant shrubs include broom snakeweed and fringed sagewort. This plant community is relatively stable. The thick sod and competitive advantage prevents other species from establishing. This plant community is less productive than the HCPC. Runoff increases and infiltration will decrease. Soil erosion will be minimal.

Table 6. Annual production by plant type

Plant Type	Low (Kg/Hectare)	Representative Value (Kg/Hectare)	High (Kg/Hectare)
Grass/Grasslike	387	749	1334
Forb	39	90	140
Shrub/Vine	22	58	95
Total	448	897	1569

Figure 7. Plant community growth curve (percent production by month).
ND5304, Missouri Coteau, warm-season dominant, cool-season sub-dominant.. Warm-season dominant, cool-season sub-dominant..

Jan	Feb	Mar	Apr	May	Jun	Jul	Aug	Sep	Oct	Nov	Dec
0	0	1	5	20	38	25	8	3	0	0	0

State 3 Low Plant Density, Bluegrass/Sedge

Community 3.1 Low Plant Density, Bluegrass/Sedge

This plant community develops after an extended period of 15 or more years of non-use by herbivores and exclusion of fire. This plant community is dispersed throughout the pasture, encircling spot grazed areas, and areas distant from water sources. This is a typical pattern found in properly stocked pastures grazed season-long. Plant litter may accumulate as this plant community first develops. Due to a lack of tiller stimulation and sunlight, native bunchgrasses typically develop dead centers and native rhizomatous grasses are limited to colonies. Standing decadent plants and moderate litter covers shorter understory species (i.e. short grasses and sedges), restricting their ability to capture adequate sunlight for photosynthesis. Vigor and diversity of native plants are reduced. Annual and/or biennial forbs and annual grasses commonly fill interspaces once occupied by desirable species. Kentucky bluegrass, crested wheatgrass, smooth brome grass, cheatgrass and sweetclover tend to invade and may dominate this plant community. Other grasses present include western wheatgrass, needleandthread, and green needlegrass. The common forbs include green sagewort, cudweed and heath aster. Fringed sagewort and brome snakeweed are the principal shrubs. This plant community is resistant to change without prescribed grazing or fire. The combination of both grazing and fire is most effective in moving this plant community towards the HCPC. Soil erosion is low. Compared to the HCPC, infiltration is reduced to the lower root zone. Runoff is similar to the HCPC. This plant community tends to favor early cool season plant species which are moisture loving and usually tends to utilize the spring moisture quickly causing the forage base to become dry and not very palatable early in the summer. Once this plant community is reached, any of the preferred treatments can readily return the diversity and production of the site.

Table 7. Annual production by plant type

Plant Type	Low (Kg/Hectare)	Representative Value (Kg/Hectare)	High (Kg/Hectare)
Grass/Grasslike	1222	1601	1961
Forb	90	191	308
Shrub/Vine	34	114	196
Total	1346	1906	2465

Figure 9. Plant community growth curve (percent production by month).
ND5302, Missouri Coteau, cool-season dominant, warm-season sub-dominant.. Cool-season dominant, warm-season sub-dominant..

Jan	Feb	Mar	Apr	May	Jun	Jul	Aug	Sep	Oct	Nov	Dec
0	0	3	7	23	42	15	5	4	1	0	0

Additional community tables

Table 8. Community 1.1 plant community composition

Group	Common Name	Symbol	Scientific Name	Annual Production (Kg/Hectare)	Foliar Cover (%)
Grass/Grasslike					
1	Needlegrasses			247–493	
	porcupinegrass	HESP11	<i>Hesperostipa spartea</i>	123–370	–
	green needlegrass	NAVI4	<i>Nassella viridula</i>	123–370	–
	needle and thread	HECOC8	<i>Hesperostipa comata ssp. comata</i>	49–247	–
2	Warm-Season Mid Grasses			247–493	
	little bluestem	SCSC	<i>Schizachyrium scoparium</i>	123–370	–
	sideoats grama	BOCU	<i>Bouteloua curtipendula</i>	123–370	–
	plains muhly	MUCU3	<i>Muhlenbergia cuspidata</i>	49–197	–
3	Warm-Season Tall Grasses			123–370	
	big bluestem	ANGE	<i>Andropogon gerardii</i>	123–370	–
	prairie sandreed	CALO	<i>Calamovilfa longifolia</i>	49–247	–
4	Wheatgrass			123–247	
	slender wheatgrass	ELTR7	<i>Elymus trachycaulus</i>	49–247	–
	western wheatgrass	PASM	<i>Pascopyrum smithii</i>	49–247	–
5	Warm-Season Short Grasses			123–247	
	blue grama	BOGR2	<i>Bouteloua gracilis</i>	123–247	–
	hairy grama	BOHI2	<i>Bouteloua hirsuta</i>	0–123	–
6	Native Grasses/Grass-Likes			123–247	
	sedge	CAREX	<i>Carex</i>	49–197	–
	Grass, perennial	2GP	<i>Grass, perennial</i>	0–123	–
	prairie Junegrass	KOMA	<i>Koeleria macrantha</i>	25–74	–
	threeawn	ARIST	<i>Aristida</i>	25–49	–
	plains reedgrass	CAMO	<i>Calamagrostis montanensis</i>	0–49	–
Forb					
8	Forbs			123–247	
	Forb, perennial	2FP	<i>Forb, perennial</i>	25–123	–
	white sagebrush	ARLU	<i>Artemisia ludoviciana</i>	25–74	–
	Forb, annual	2FA	<i>Forb, annual</i>	25–74	–
	blacksamson echinacea	ECAN2	<i>Echinacea angustifolia</i>	25–74	–
	blazing star	LIATR	<i>Liatris</i>	25–74	–
	scarlet globemallow	SPCO	<i>Sphaeralcea coccinea</i>	25–74	–
	white heath aster	SYER	<i>Symphotrichum ericoides</i>	25–74	–
	American vetch	VIAM	<i>Vicia americana</i>	25–49	–
	prairie clover	DALEA	<i>Dalea</i>	25–49	–
	large Indian breadroot	PEES	<i>Pedimelum esculentum</i>	0–49	–
	upright prairie coneflower	RACO3	<i>Ratibida columnifera</i>	25–49	–
	goldenrod	SOLID	<i>Solidago</i>	25–49	–
	tarragon	ARDR4	<i>Artemisia dracunculus</i>	0–49	–

	scarlet beeblossom	GACO5	<i>Gaura coccinea</i>	0–25	–
	rush skeletonplant	LYJU	<i>Lygodesmia juncea</i>	0–25	–
	lacy tansyaster	MAPI	<i>Machaeranthera pinnatifida</i>	0–25	–
	purple locoweed	OXLA3	<i>Oxytropis lambertii</i>	0–25	–
	groundplum milkvetch	ASCR2	<i>Astragalus crassicaarpus</i>	0–25	–
	plains milkvetch	ASGI5	<i>Astragalus gilviflorus</i>	0–25	–
	wavyleaf thistle	CIUN	<i>Cirsium undulatum</i>	0–25	–
	western yarrow	ACMIO	<i>Achillea millefolium var. occidentalis</i>	0–25	–
	onion	ALLIU	<i>Allium</i>	0–25	–
	pussytoes	ANTEN	<i>Antennaria</i>	0–25	–
	scurfpea	PSORA2	<i>Psoraleidium</i>	0–25	–
	eastern pasqueflower	PUPA5	<i>Pulsatilla patens</i>	0–25	–
Shrub/Vine					
9	Shrubs			49–123	
	Subshrub (<.5m)	2SUBS	<i>Subshrub (<.5m)</i>	0–123	–
	leadplant	AMCA6	<i>Amorpha canescens</i>	25–123	–
	prairie sagewort	ARFR4	<i>Artemisia frigida</i>	25–123	–
	skunkbush sumac	RHTR	<i>Rhus trilobata</i>	25–123	–
	rose	ROSA5	<i>Rosa</i>	25–123	–
	soapweed yucca	YUGL	<i>Yucca glauca</i>	0–74	–
	creeping juniper	JUHO2	<i>Juniperus horizontalis</i>	0–49	–
	pricklypear	OPUNT	<i>Opuntia</i>	0–49	–

Table 9. Community 2.1 plant community composition

Group	Common Name	Symbol	Scientific Name	Annual Production (Kg/Hectare)	Foliar Cover (%)
Grass/Grasslike					
1	Needlegrasses			9–45	
	needle and thread	HECOC8	<i>Hesperostipa comata ssp. comata</i>	9–45	–
	green needlegrass	NAVI4	<i>Nassella viridula</i>	0–18	–
2	Warm-Season Mid Grasses			18–90	
	little bluestem	SCSC	<i>Schizachyrium scoparium</i>	18–90	–
	sideoats grama	BOCU	<i>Bouteloua curtipendula</i>	0–18	–
3	Warm-Season Tall Grasses			0–18	
	prairie sandreed	CALO	<i>Calamovilfa longifolia</i>	0–18	–
4	Wheatgrass			9–63	
	western wheatgrass	PASM	<i>Pascopyrum smithii</i>	9–63	–
	slender wheatgrass	ELTR7	<i>Elymus trachycaulus</i>	0–45	–
5	Warm-Season Short Grasses			90–179	
	blue grama	BOGR2	<i>Bouteloua gracilis</i>	90–179	–
	hairy grama	BOHI2	<i>Bouteloua hirsuta</i>	0–90	–
6	Native Grasses/Grass-Likes			90–224	
	sedge	CAREX	<i>Carex</i>	45–179	–
	Grass, perennial	2GP	<i>Grass, perennial</i>	0–45	–

	threeawn	ARIST	<i>Aristida</i>	9-45	-
	prairie Junegrass	KOMA	<i>Koeleria macrantha</i>	9-18	-
	plains reedgrass	CAMO	<i>Calamagrostis montanensis</i>	0-9	-
7	Non-Native Grasses			9-54	
	Kentucky bluegrass	POPR	<i>Poa pratensis</i>	9-54	-
	smooth brome	BRIN2	<i>Bromus inermis</i>	0-45	-
	cheatgrass	BRTE	<i>Bromus tectorum</i>	0-36	-
	crested wheatgrass	AGCR	<i>Agropyron cristatum</i>	0-18	-
Forb					
8	Forbs			45-135	
	Forb, perennial	2FP	<i>Forb, perennial</i>	9-45	-
	sweetclover	MELIL	<i>Melilotus</i>	0-45	-
	Forb, annual	2FA	<i>Forb, annual</i>	9-36	-
	white sagebrush	ARLU	<i>Artemisia ludoviciana</i>	9-36	-
	white heath aster	SYER	<i>Symphotrichum ericoides</i>	9-36	-
	yellow salsify	TRDU	<i>Tragopogon dubius</i>	0-36	-
	common dandelion	TAOF	<i>Taraxacum officinale</i>	9-27	-
	goldenrod	SOLID	<i>Solidago</i>	9-27	-
	scarlet globemallow	SPCO	<i>Sphaeralcea coccinea</i>	9-27	-
	scurfpea	PSORA2	<i>Psoralegium</i>	9-27	-
	eastern pasqueflower	PUPA5	<i>Pulsatilla patens</i>	0-27	-
	tarragon	ARDR4	<i>Artemisia dracunculus</i>	9-27	-
	lacy tansyaster	MAPI	<i>Machaeranthera pinnatifida</i>	0-18	-
	blacksamson echinacea	ECAN2	<i>Echinacea angustifolia</i>	0-18	-
	blazing star	LIATR	<i>Liatris</i>	9-18	-
	upright prairie coneflower	RACO3	<i>Ratibida columnifera</i>	9-18	-
	pussytoes	ANTEN	<i>Antennaria</i>	0-18	-
	western yarrow	ACMIO	<i>Achillea millefolium var. occidentalis</i>	0-18	-
	onion	ALLIU	<i>Allium</i>	0-9	-
	plains milkvetch	ASGI5	<i>Astragalus gilviflorus</i>	0-9	-
	wavyleaf thistle	CIUN	<i>Cirsium undulatum</i>	0-9	-
	prairie clover	DALEA	<i>Dalea</i>	0-9	-
	purple locoweed	OXLA3	<i>Oxytropis lambertii</i>	0-9	-
	rush skeletonplant	LYJU	<i>Lygodesmia juncea</i>	0-9	-
Shrub/Vine					
9	Shrubs			27-90	
	skunkbush sumac	RHTR	<i>Rhus trilobata</i>	9-45	-
	rose	ROSA5	<i>Rosa</i>	9-45	-
	soapweed yucca	YUGL	<i>Yucca glauca</i>	0-45	-
	Subshrub (<.5m)	2SUBS	<i>Subshrub (<.5m)</i>	0-45	-
	prairie sagewort	ARFR4	<i>Artemisia frigida</i>	9-45	-
	creeping juniper	JUHO2	<i>Juniperus horizontalis</i>	0-18	-

pricklypear	OPUNT	<i>Opuntia</i>	9-18	-
-------------	-------	----------------	------	---

Table 10. Community 3.1 plant community composition

Group	Common Name	Symbol	Scientific Name	Annual Production (Kg/Hectare)	Foliar Cover (%)
Grass/Grasslike					
1	Needlegrasses			95-286	
	needle and thread	HECOC8	<i>Hesperostipa comata ssp. comata</i>	38-191	-
	green needlegrass	NAVI4	<i>Nassella viridula</i>	38-191	-
	porcupinegrass	HESP11	<i>Hesperostipa spartea</i>	0-57	-
2	Warm-Season Mid Grasses			57-191	
	little bluestem	SCSC	<i>Schizachyrium scoparium</i>	19-191	-
	plains muhly	MUCU3	<i>Muhlenbergia cuspidata</i>	19-96	-
	sideoats grama	BOCU	<i>Bouteloua curtipendula</i>	19-38	-
3	Warm-Season Tall Grasses			19-95	
	big bluestem	ANGE	<i>Andropogon gerardii</i>	0-95	-
	prairie sandreed	CALO	<i>Calamovilfa longifolia</i>	19-95	-
4	Wheatgrass			38-191	
	slender wheatgrass	ELTR7	<i>Elymus trachycaulus</i>	38-191	-
	western wheatgrass	PASM	<i>Pascopyrum smithii</i>	38-191	-
5	Warm-Season Short Grasses			19-95	
	blue grama	BOGR2	<i>Bouteloua gracilis</i>	19-95	-
	hairy grama	BOHI2	<i>Bouteloua hirsuta</i>	0-57	-
6	Native Grasses/Grass-Likes			95-229	
	sedge	CAREX	<i>Carex</i>	38-191	-
	Grass, perennial	2GP	<i>Grass, perennial</i>	0-95	-
	threeawn	ARIST	<i>Aristida</i>	19-95	-
	prairie Junegrass	KOMA	<i>Koeleria macrantha</i>	19-38	-
	plains reedgrass	CAMO	<i>Calamagrostis montanensis</i>	0-19	-
7	Non-Native Grasses			95-343	
	Kentucky bluegrass	POPR	<i>Poa pratensis</i>	38-343	-
	smooth brome	BRIN2	<i>Bromus inermis</i>	19-191	-
	cheatgrass	BRTE	<i>Bromus tectorum</i>	0-152	-
	crested wheatgrass	AGCR	<i>Agropyron cristatum</i>	0-95	-
Forb					
8	Forbs			95-286	
	sweetclover	MELIL	<i>Melilotus</i>	0-152	-
	Forb, annual	2FA	<i>Forb, annual</i>	19-95	-
	Forb, perennial	2FP	<i>Forb, perennial</i>	19-95	-
	white heath aster	SYER	<i>Symphyotrichum ericoides</i>	19-95	-
	common dandelion	TAOF	<i>Taraxacum officinale</i>	19-76	-
	yellow salsify	TRDU	<i>Tragopogon dubius</i>	0-76	-
	goldenrod	SOLID	<i>Solidago</i>	19-76	-
	tarragon	ARDR4	<i>Artemisia dracunculus</i>	19-76	-
	white sagebrush	ARDRI	<i>Artemisia ludoviciana</i>	10-57	-

	white sagebrush	ARLE	<i>Artemisia tridentata</i>	19-57	-
	scurfpea	PSORA2	<i>Psoraleidium</i>	19-57	-
	prairie clover	DALEA	<i>Dalea</i>	0-38	-
	blacksamson echinacea	ECAN2	<i>Echinacea angustifolia</i>	0-38	-
	blazing star	LIATR	<i>Liatris</i>	19-38	-
	western yarrow	ACMIO	<i>Achillea millefolium var. occidentalis</i>	0-38	-
	scarlet globemallow	SPCO	<i>Sphaeralcea coccinea</i>	19-38	-
	upright prairie coneflower	RACO3	<i>Ratibida columnifera</i>	19-38	-
	American vetch	VIAM	<i>Vicia americana</i>	0-19	-
	onion	ALLIU	<i>Allium</i>	0-19	-
	pussytoes	ANTEN	<i>Antennaria</i>	0-19	-
	groundplum milkvetch	ASCR2	<i>Astragalus crassicaarpus</i>	0-19	-
	plains milkvetch	ASGI5	<i>Astragalus gilviflorus</i>	0-19	-
	wavyleaf thistle	CIUN	<i>Cirsium undulatum</i>	0-19	-
	rush skeletonplant	LYJU	<i>Lygodesmia juncea</i>	0-19	-
	lacy tansyaster	MAPI	<i>Machaeranthera pinnatifida</i>	0-19	-
	scarlet beeblossom	GACO5	<i>Gaura coccinea</i>	0-19	-
	eastern pasqueflower	PUPA5	<i>Pulsatilla patens</i>	0-19	-
	purple locoweed	OXLA3	<i>Oxytropis lambertii</i>	0-19	-
Shrub/Vine					
9	Shrubs			38-191	
	Subshrub (<.5m)	2SUBS	<i>Subshrub (<.5m)</i>	0-95	-
	prairie sagewort	ARFR4	<i>Artemisia frigida</i>	19-95	-
	rose	ROSA5	<i>Rosa</i>	19-95	-
	skunkbush sumac	RHTR	<i>Rhus trilobata</i>	19-76	-
	soapweed yucca	YUGL	<i>Yucca glauca</i>	0-57	-
	creeping juniper	JUHO2	<i>Juniperus horizontalis</i>	0-38	-
	leadplant	AMCA6	<i>Amorpha canescens</i>	0-38	-
	pricklypear	OPUNT	<i>Opuntia</i>	0-19	-

Animal community

Wildlife Interpretations:
Under development.

Grazing Interpretations:

This site is well adapted to managed grazing by domestic livestock. The predominance of herbaceous plants across all plant community phases best lends these sites to grazing by cattle but other domestic grazers with differing diet preferences may also be a consideration depending upon management objectives. Often, the current plant community does not entirely match any particular plant community (as described in the ecological site description). Because of this, a resource inventory is necessary to document plant composition and production. Proper interpretation of this inventory data will permit the establishment of a safe, initial stocking rate for the type and class of animals and level of grazing management. More accurate stocking rate estimates should eventually be calculated using actual stocking rate information and monitoring data.

Hydrological functions

Water is the principal factor limiting herbage production on this site. The site is dominated by soils in hydrologic groups C and D. Infiltration varies from slow to moderately rapid and runoff potential varies from medium to high for this site depending on soil hydrologic group, slope and ground cover. In many cases, areas with greater than 75% ground cover have the greatest potential for high infiltration and lower runoff. An exception would be where short grasses form a dense sod and dominate the site. Areas where ground cover is less than 50% have the greatest potential to have reduced infiltration and higher runoff (refer to Section 4, NRCS National Engineering Handbook for runoff quantities and hydrologic curves).

Recreational uses

This site provides hunting opportunities for upland game species. The wide variety of plants which bloom from spring until fall have an esthetic value that appeals to visitors.

Wood products

No appreciable wood products are present on the site.

Other products

Seed harvest of native plant species can provide additional income on this site.

Inventory data references

Information presented here has been derived from NRCS clipping and other inventory data. Also, field knowledge of range-trained personnel was used. All descriptions were peer reviewed and/or field-tested by various private, state and federal agency specialists. Those involved in developing this site description include: Stan Boltz, NRCS Range Management Specialist; Michael D. Brand, State Land Dept., Director Surface Management; David Dewald, NRCS State Biologist; Paul Drayton, NRCS District Conservationist; Jody Forman, NRCS Range Management Specialist; Dennis Froemke, NRCS Range Management Specialist; Jeff Printz, NRCS State Range Management Specialist; Josh Saunders, NRCS Range Management Specialist; Kevin Sedivec, Extension Rangeland Management Specialist; Darrell Vanderbusch, NRCS Resource Soil Scientist; and Lee Voigt, NRCS Range Management Specialist.

Data Source Number of Records Sample Period State County
SCS-RANGE-417 1 1969 ND Emmons

Other references

High Plains Regional Climate Center, University of Nebraska, 830728 Chase Hall, Lincoln, NE 68583-0728.
(<http://hprcc.unl.edu>)

USDA, NRCS. National Water and Climate Center, 101 SW Main, Suite 1600, Portland, OR 97204-3224.
(<http://www.wcc.nrcs.usda.gov>)

USDA, NRCS. National Range and Pasture Handbook, September 1997

USDA, NRCS. National Soil Information System, Information Technology Center, 2150 Centre Avenue, Building A, Fort Collins, CO 80526. (<http://nasis.nrcs.usda.gov>)

USDA, NRCS. 2001. The PLANTS Database, Version 3.1 (<http://plants.usda.gov>). National Plant Data Center, Baton Rouge, LA 70874-4490 USA.

USDA, NRCS, Various Published Soil Surveys.

Contributors

Jeff Printz

Jeff Printz/Stan Boltz

Approval

Suzanne Mayne-Kinney, 1/11/2024

Rangeland health reference sheet

Interpreting Indicators of Rangeland Health is a qualitative assessment protocol used to determine ecosystem condition based on benchmark characteristics described in the Reference Sheet. A suite of 17 (or more) indicators are typically considered in an assessment. The ecological site(s) representative of an assessment location must be known prior to applying the protocol and must be verified based on soils and climate. Current plant community cannot be used to identify the ecological site.

Author(s)/participant(s)	Jeff Printz, Stan Boltz, Lee Voigt, Jody Forman
Contact for lead author	Jeff.printz@nd.usda.gov 701-530-2080
Date	03/01/2012
Approved by	Suzanne Mayne-Kinney
Approval date	
Composition (Indicators 10 and 12) based on	Annual Production

Indicators

- 1. Number and extent of rills:** None on slopes < 30%. Rills may be observable on slopes >30% but they would be < 12 inches in length and disconnected.

- 2. Presence of water flow patterns:** None on slopes < 30%. On slopes > 30%, water flow patterns are short, irregular, and discontinuous.

- 3. Number and height of erosional pedestals or terracettes:** None on slopes < 30%. May be evident on slopes > 30% but only where associated with rills.

- 4. Bare ground from Ecological Site Description or other studies (rock, litter, lichen, moss, plant canopy are not bare ground):** Bare ground < 10%. Patch size < 2 inches and disconnected.

- 5. Number of gullies and erosion associated with gullies:** None.

- 6. Extent of wind scoured, blowouts and/or depositional areas:** None.

- 7. Amount of litter movement (describe size and distance expected to travel):** None on slopes on < 30%. Some short movement of small sized plant litter may be observed associated with rills on slopes of > 30%.

- 8. Soil surface (top few mm) resistance to erosion (stability values are averages - most sites will show a range of values):** Average 5 to 6. Soil surface fragments will typically retain structure indefinitely when dipped in distilled water.

9. **Soil surface structure and SOM content (include type of structure and A-horizon color and thickness):** Use soil series description for depth, color and structure of A horizon/surface layer.
-
10. **Effect of community phase composition (relative proportion of different functional groups) and spatial distribution on infiltration and runoff:** Combination of shallow and deep rooted species (mid & tall rhizomatous and tufted perennial cool- and warm-season grasses) with fine and coarse roots positively influences infiltration.
-
11. **Presence and thickness of compaction layer (usually none; describe soil profile features which may be mistaken for compaction on this site):** No management induced compaction layer present. Bk layer should not be confused for a compacted layer.
-
12. **Functional/Structural Groups (list in order of descending dominance by above-ground annual-production or live foliar cover using symbols: >>, >, = to indicate much greater than, greater than, and equal to):**
- Dominant: Mid, cool-season bunchgrasses = mid, warm-season grasses >
- Sub-dominant: Tall, warm-season grasses >
- Other: Mid, cool-season rhizomatous = short, warm-season grasses = forbs > grass-likes > shrubs = short, cool-season grasses
- Additional: Due to differing root structure and distribution, Kentucky bluegrass and smooth brome grass do not fit into reference plant community F/S groups.
-
13. **Amount of plant mortality and decadence (include which functional groups are expected to show mortality or decadence):** None.
-
14. **Average percent litter cover (%) and depth (in):** Plant litter is in contact with soil surface.
-
15. **Expected annual annual-production (this is TOTAL above-ground annual-production, not just forage annual-production):** Representative value = 2200 lbs./ac air dry with a range of 1500 to 2900 lbs./ac air dry depending upon growing conditions.
-
16. **Potential invasive (including noxious) species (native and non-native). List species which BOTH characterize degraded states and have the potential to become a dominant or co-dominant species on the ecological site if their future establishment and growth is not actively controlled by management interventions. Species that become dominant for only one to several years (e.g., short-term response to drought or wildfire) are not invasive plants. Note that unlike other indicators, we are describing what is NOT expected in the reference state for the ecological site:** State and local noxious weeds, Kentucky bluegrass, smooth brome grass
-
17. **Perennial plant reproductive capability:** All species exhibit high vigor relative to climatic conditions. Do not rate based solely on seed production. Perennial grasses should have vigorous rhizomes or tillers.

