

Ecological site R053BY014ND Choppy Sands

Last updated: 1/11/2024
Accessed: 07/17/2024

General information

Provisional. A provisional ecological site description has undergone quality control and quality assurance review. It contains a working state and transition model and enough information to identify the ecological site.

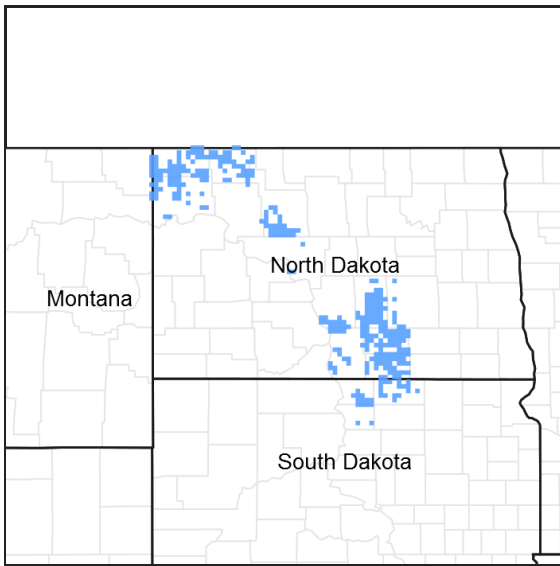

Figure 1. Mapped extent

Areas shown in blue indicate the maximum mapped extent of this ecological site. Other ecological sites likely occur within the highlighted areas. It is also possible for this ecological site to occur outside of highlighted areas if detailed soil survey has not been completed or recently updated.

Classification relationships

Level IV Ecoregions of the Conterminous United States: 42a – Missouri Coteau; 42b – Collapsed Glacial Outwash; 42c – Missouri Coteau Slope; 42d – Northern Missouri Coteau; 42f – Southern Missouri Coteau Slope; 42g – Ponca Plains; and 42h – Southern River Breaks.

Associated sites

R053BY007ND	Sands
R053BY008ND	Sandy

Similar sites

R053BY008ND	<p>Sandy [Does not receive additional moisture. Found on dry uplands upslope from Loamy Overflow site, down slope from Thin Upland or Shallow Loamy sites. Similar landscape position as Loamy, Sands, Clayey sites; will ribbon up to 1 inch. Indicator species are prairie sandreed with western wheatgrass and green needlegrass intermixed. This site has more production, thicker “A” horizon and a mollic epipedon, lime deeper than 6 inches from the surface, less little bluestem and sand bluestem, less production.]</p>
-------------	--

R054XY025ND	<p>Sands</p> <p>[Does not receive additional moisture. Found on dry uplands, upslope from Loamy Overflow site, down slope from Thin Upland or Shallow Loamy sites. Similar landscape position as Loamy, Sandy, and Clayey sites. Won't form a ribbon; indicator species are sand bluestem and prairie sandreed evenly mixed, some Canada wildrye, penstemon, and leadplant and western snowberry. This site has more production, thicker "A" horizon and a mollic epipedon, less needleandthread, less choppy landscape.]</p>
-------------	--

Table 1. Dominant plant species

Tree	Not specified
Shrub	Not specified
Herbaceous	(1) <i>Andropogon hallii</i> (2) <i>Calamovilfa longifolia</i>

Physiographic features

This site typically occurs on gently rolling to strongly sloping uplands.

Table 2. Representative physiographic features

Landforms	(1) Outwash plain (2) Terrace
Flooding frequency	None
Ponding frequency	None
Elevation	488–610 m
Slope	0–25%
Water table depth	203 cm
Aspect	Aspect is not a significant factor

Climatic features

MLRA 53B is considered to have a continental climate – cold winters and hot summers, low humidity, light rainfall, and much sunshine. Extremes in temperature are characteristic. The climate is the result of this MLRA's location in the geographic center of North America. There are few natural barriers on the northern Great Plains. The air masses move unobstructed across the plains and account for rapid changes in temperature.

Annual precipitation ranges from 15 to 20 inches per year. The normal average annual temperature is about 41° F. January is the coldest month with average temperatures ranging from about 4° F (Powers Lake, ND) to about 10° F (Pollock, SD). July is the warmest month with temperatures averaging from about 67° F (Powers Lake, ND) to about 72° F (Pollock, SD). The range of normal average monthly temperatures between the coldest and warmest months is about 62° F. This large annual range attests to the continental nature of this MLRA's climate. Winds average about 11 miles per hour annually, ranging from about 13 miles per hour during the spring to about 10 miles per hour during the summer. Daytime winds are generally stronger than nighttime and occasional strong storms may bring brief periods of high winds with gusts to more than 50 miles per hour.

Growth of native cool-season plants begins in late March and continues to early to mid July. Native warm-season plants begin growth in mid May and continue to the end of August. Green up of cool-season plants can occur in September and October when adequate soil moisture is present.

Table 3. Representative climatic features

Frost-free period (average)	135 days
Freeze-free period (average)	156 days
Precipitation total (average)	508 mm

Influencing water features

No significant water features influence this site.

Soil features

These are deep and very deep, excessively drained, coarse textured soils that have a thin surface horizon. Saturated hydraulic conductivity is moderately rapid to very rapid and available water capacity is moderate to very low. Salinity and sodicity are none.

These soils are highly susceptible to wind erosion. This site is on rises and ridges on nearly level to very steep outwash plains and terraces. Slope ranges from 0 to 25 percent. This site should show slight evidence of wind scoured areas or pedestalled plants. Water flow paths are not evident. The soil surface is unstable and areas of blow-outs can occur.

These soils are susceptible to wind erosion. Loss of the soil surface layer can result in a shift in species composition and/or production.

Major soil series correlated to this ecological site can be found in Section II of the Natural Resources Conservation Service Field Office Technical Guide or the following web sites:

<http://www.nrcs.usda.gov/technical/efotg/>

Table 4. Representative soil features

Surface texture	(1) Loamy sand (2) Loamy fine sand (3) Fine sand
Family particle size	(1) Sandy
Drainage class	Excessively drained
Permeability class	Moderately rapid to very rapid
Soil depth	203 cm
Surface fragment cover <=3"	0–5%
Surface fragment cover >3"	0%
Available water capacity (0-101.6cm)	7.62 cm
Calcium carbonate equivalent (0-101.6cm)	0–10%
Electrical conductivity (0-101.6cm)	0–2 mmhos/cm
Sodium adsorption ratio (0-101.6cm)	0
Soil reaction (1:1 water) (0-101.6cm)	6.1–8.4
Subsurface fragment volume <=3" (Depth not specified)	0–25%
Subsurface fragment volume >3" (Depth not specified)	0–5%

Ecological dynamics

This site developed under Northern Great Plains climatic conditions, and included natural influence of large herbivores and occasional fire. Changes will occur in the plant communities due to climatic conditions and/or management actions. Due to the nature of the soils, the site is considered quite fragile. Under continued adverse impacts, a rapid decline in vegetative vigor and composition will occur. Under favorable vegetative management

treatments the site can slowly return to the Historic Climax Plant Community (HCPC).

The plant community upon which interpretations are primarily based is the Historic Climax Plant Community. The HCPC has been determined by study of rangeland relic areas, areas protected from excessive disturbance, and areas under long-term rotational grazing regimes. Trends in plant community dynamics ranging from heavily grazed to lightly grazed areas, seasonal use pastures, and historical accounts also have been considered. Subclimax plant communities, states, transitional pathways, and thresholds have been determined through similar studies and experience.

Continuous grazing or continuous seasonal (spring) grazing without adequate recovery opportunities following each grazing event during the growing season will initially cause needleandthread, blue grama and threadleaf sedge to increase. Species such as sand bluestem and prairie sandreed decrease in frequency and production. Heavy continuous grazing results in an increased amount of threadleaf sedge and forbs, and elimination of sand bluestem, prairie sandreed and little bluestem.

Non-use (rest) and/or lack of fire will likely cause litter to increase causing decadence, mortality and increased introduced cool-season grasses. Heavy continuous grazing, wildfire, excessive defoliation or any type of physical disturbance can lead to serious erosion problems on these fragile soils (i.e., blowouts).

The following is a diagram that illustrates the common plant communities that can occur on the site and the transition pathways between communities. The ecological processes will be discussed in more detail in the plant community descriptions following the diagram.

State and transition model

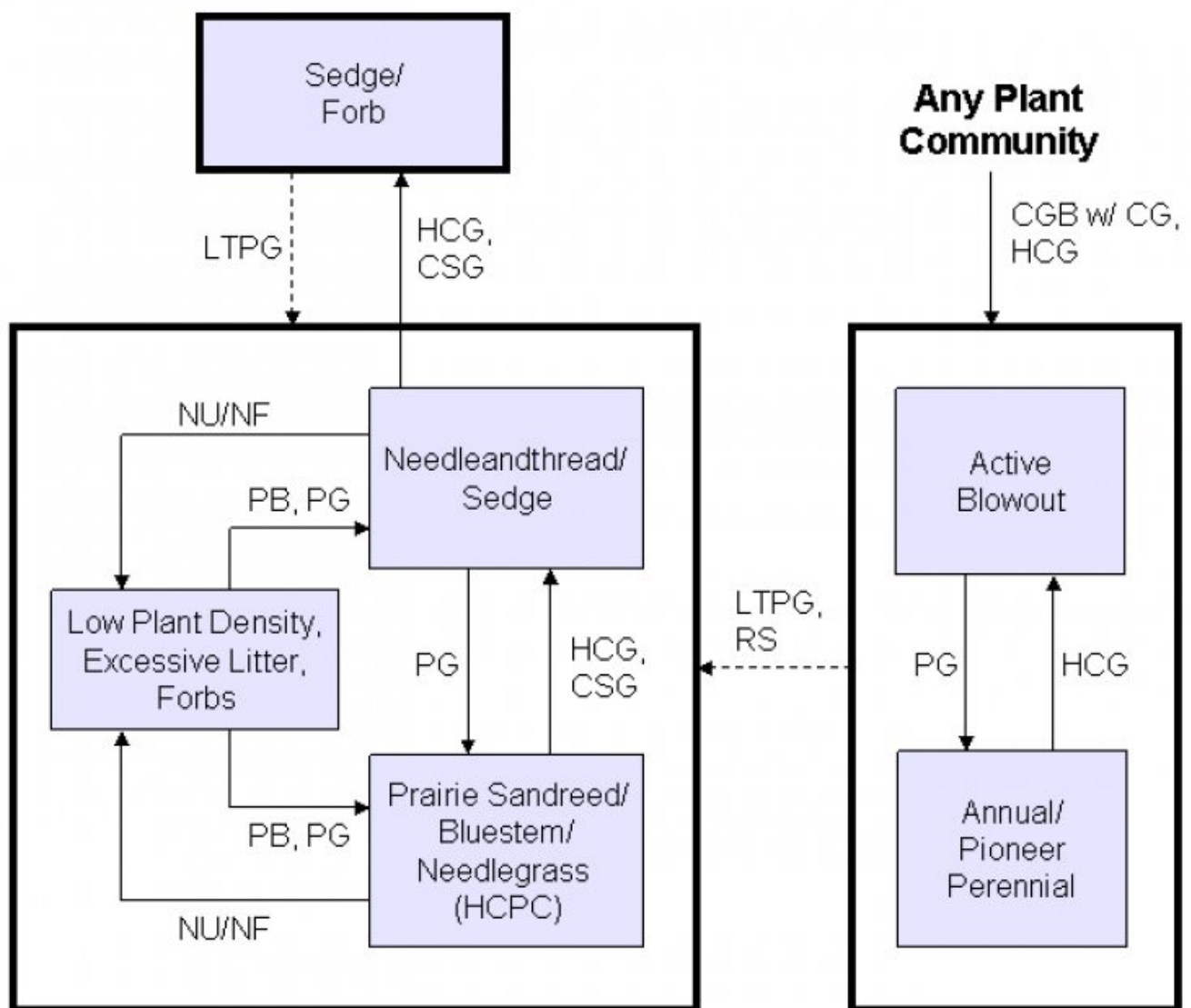

CGB w/ CG – Cropped go-back with continuous grazing; **CSG** – Continuous seasonal grazing; **HCG** – Heavy continuous grazing; **HCPC** – Historical Climax Plant Community; **LTPG** – Long-term prescribed grazing; **NU/NF** – Extended period of non-use & no fire; **PB** – Prescribed burning; **PG** – Prescribed grazing; **RS** – Range seeding with prescribed grazing.

State 1
Prairie Sandreed/Bluestem/Needlegrass (HCPC)

Community 1.1
Prairie Sandreed/Bluestem/Needlegrass (HCPC)

This is the interpretive plant community and is considered to be the Historic Climax Plant Community (HCPC). This community evolved with grazing by large herbivores and occasional prairie fire. It is well suited for grazing by domestic livestock and can be found on areas that are properly managed with prescribed grazing that allows for proper utilization, changes in season of use and adequate recovery periods following each grazing event. The potential vegetation is about 85% grasses or grass-like plants, 10% forbs, and 5% shrubs. Warm season grasses such as sand bluestem and prairie sandreed dominate the plant community. Other grasses and grass-like plants occurring on the site include needleandthread, little bluestem, blue grama, hairy grama, western wheatgrass and sedges. Significant forbs include penstemon, green sagewort, stiff sunflower, and spiderwort. Leadplant, rose and yucca are the principal shrubs. This plant community is well adapted to the Northern Great Plains climatic conditions. Individual species can vary greatly in production depending on growing conditions (timing and amount of precipitation and temperature). Community dynamics, nutrient cycle, water cycle and energy flow are functioning properly. Plant litter is properly distributed with very little movement off-site and natural plant mortality is very low. The diversity in plant species allows for high drought tolerance. Waterflow patterns may not be present, but there is a very high risk of wind erosion and eventually blowouts if vegetative cover is not adequate. Cryptogamic crusts can be present, but typically only cover 1-2% of the soil surface. Some pedestalling of plants occurs, but it is not very evident on casual observation and occurs on less than 5% of the plants. Overall this site (the interpretive plant community) has the appearance of being stable and productive.

Table 5. Annual production by plant type

Plant Type	Low (Kg/Hectare)	Representative Value (Kg/Hectare)	High (Kg/Hectare)
Grass/Grasslike	1110	1695	2281
Forb	90	143	196
Shrub/Vine	34	67	101
Total	1234	1905	2578

Figure 5. Plant community growth curve (percent production by month).
ND5304, Missouri Coteau, warm-season dominant, cool-season sub-
dominant.. Warm-season dominant, cool-season sub-dominant..

Jan	Feb	Mar	Apr	May	Jun	Jul	Aug	Sep	Oct	Nov	Dec
0	0	1	5	20	38	25	8	3	0	0	0

State 2
Needleandthread/Sedge

Community 2.1
Needleandthread/Sedge

This plant community can quickly develop from the adverse effects of long-term, heavy continuous grazing. Sand bluestem and prairie sandreed have been greatly reduced. Needleandthread and threadleaf sedge have increased and are the dominant species. Other grasses include western wheatgrass, blue grama, red threeawn, sand dropseed, blowout grass and prairie junegrass. Forbs such as western ragweed, green sagewort, hairy goldaster, lemon scurfpea and sweetclover may also be present. Yucca, rose, fringed sagewort and cactus have also increased. Annual production, and consequently litter amounts, have been reduced substantially. Nutrient cycle, water cycle and energy flow are becoming impaired. This plant community is at risk of losing all tall warm season grasses. Wind scoured areas may exist where cover has been reduced or eliminated.

Table 6. Annual production by plant type

Plant Type	Low (Kg/Hectare)	Representative Value (Kg/Hectare)	High (Kg/Hectare)
Grass/Grasslike	392	767	1362
Forb	39	90	140
Shrub/Vine	17	40	67
Total	448	897	1569

Figure 7. Plant community growth curve (percent production by month).
ND5302, Missouri Coteau, cool-season dominant, warm-season sub-dominant.. Cool-season dominant, warm-season sub-dominant..

Jan	Feb	Mar	Apr	May	Jun	Jul	Aug	Sep	Oct	Nov	Dec
0	0	3	7	23	42	15	5	4	1	0	0

State 3 Sedge/Forb

Community 3.1 Sedge/Forb

This plant community developed from heavy continuous grazing without adequate recovery periods between grazing events or continuous seasonal (spring) grazing. An increased amount of threadleaf sedge and forbs characterize this plant community. Sand bluestem and prairie sandreed have been reduced to negligible amounts. Other grasses and grass-likes present include sand dropseed, red threeawn, needleandthread, prairie junegrass and sandbur. Forbs commonly found in this plant community include green sagewort, lemon scurfpea, western ragweed, buffalo bur and hairy goldaster. Shrubs present include fringed sagewort, rose and possibly yucca. Species diversity has shifted from a grass-dominated community to a forb dominated community. Production has been significantly decreased due to reduction of tall and mid-grass species. Energy flow, water cycle and mineral cycle have been negatively affected. Litter levels are very low and unevenly distributed. Soil erosion may be a concern on steeper slopes and exposed areas.

Table 7. Annual production by plant type

Plant Type	Low (Kg/Hectare)	Representative Value (Kg/Hectare)	High (Kg/Hectare)
Grass/Grasslike	151	415	790
Forb	50	99	146
Shrub/Vine	22	47	73
Total	223	561	1009

Figure 9. Plant community growth curve (percent production by month).
ND5303, Missouri Coteau, cool-season/warm-season co-dominant.. Cool-season, warm-season co-dominant..

Jan	Feb	Mar	Apr	May	Jun	Jul	Aug	Sep	Oct	Nov	Dec
0	0	2	6	21	40	20	6	4	1	0	0

State 4 Low Plant Density, Excessive Litter, Forbs

Community 4.1 Low Plant Density, Excessive Litter, Forbs

This plant community develops after an extended period of 10 or more years of non-use by herbivores or exclusion of fire. Non-native grasses, such as Kentucky bluegrass and cheatgrass tend to invade and may dominate this plant

community. Other grasses and grass-likes present include sand bluestem, prairie sandreed, little bluestem, Canada wildrye, western wheatgrass, and threadleaf sedge. The common forbs include green sagewort, goldenrod, western wallflower, prairie coneflower, western ragweed and sweetclover. Yucca and fringed sagewort are the principal shrubs. Litter buildup reduces plant vigor and density, and native seedling recruitment declines. Due to a lack of tiller stimulation and sunlight, native bunchgrasses typically develop dead centers and native rhizomatous grasses are limited to small colonies. This plant community is dispersed throughout the pasture, encircling spot grazed areas, and areas distant from water sources. This is a typical pattern found in properly stocked pastures grazed season-long. This plant community is resistant to change without prescribed grazing or fire. The combination of both grazing and fire is most effective in moving this plant community towards the HCPC. Soil erosion is low. Runoff is similar to the HCPC. Once this plant community is reached, time and external resources will be needed to see any immediate recovery in diversity.

Table 8. Annual production by plant type

Plant Type	Low (Kg/Hectare)	Representative Value (Kg/Hectare)	High (Kg/Hectare)
Grass/Grasslike	673	1255	1838
Forb	151	196	241
Shrub/Vine	73	118	163
Total	897	1569	2242

Figure 11. Plant community growth curve (percent production by month). ND5301, Missouri Coteau, cool-season dominant.. Cool-season dominant..

Jan	Feb	Mar	Apr	May	Jun	Jul	Aug	Sep	Oct	Nov	Dec
0	0	3	8	24	45	10	3	5	2	0	0

Additional community tables

Table 9. Community 1.1 plant community composition

Group	Common Name	Symbol	Scientific Name	Annual Production (Kg/Hectare)	Foliar Cover (%)
Grass/Grasslike					
1	Bluestem			286–381	
	sand bluestem	ANHA	<i>Andropogon hallii</i>	286–381	–
	little bluestem	SCSC	<i>Schizachyrium scoparium</i>	0–95	–
2	Other Native Tall Grasses			191–381	
	prairie sandreed	CALO	<i>Calamovilfa longifolia</i>	191–381	–
3	Needlegrass			191–381	
	needle and thread	HECOC8	<i>Hesperostipa comata ssp. comata</i>	95–286	–
	porcupinegrass	HESP11	<i>Hesperostipa spartea</i>	95–286	–
4	Gramma			38–95	
	blue grama	BOGR2	<i>Bouteloua gracilis</i>	19–95	–
	hairy grama	BOHI2	<i>Bouteloua hirsuta</i>	0–57	–
5	Other Native Grasses			95–191	
	western wheatgrass	PASM	<i>Pascopyrum smithii</i>	19–95	–
	sand dropseed	SPCR	<i>Sporobolus cryptandrus</i>	19–38	–
	Grass, perennial	2GP	<i>Grass, perennial</i>	19–38	–
	Scribner's rosette grass	DIOLS	<i>Dichanthelium oligosanthes var. scribnerianum</i>	19–38	–
	Canada wildrye	ELCA4	<i>Elymus canadensis</i>	19–38	–
	prairie Junegrass	KOMA	<i>Koeleria macrantha</i>	19–38	–

6	Grass-Likes			95–191	
	threadleaf sedge	CAFI	<i>Carex filifolia</i>	95–133	–
	Pennsylvania sedge	CAPE6	<i>Carex pensylvanica</i>	38–57	–
	Grass-like (not a true grass)	2GL	<i>Grass-like (not a true grass)</i>	19–38	–
Forb					
8	Forbs			95–191	
	Forb, perennial	2FP	<i>Forb, perennial</i>	19–57	–
	tarragon	ARDR4	<i>Artemisia dracunculus</i>	38–57	–
	beardtongue	PENST	<i>Penstemon</i>	38–57	–
	longbract spiderwort	TRBR	<i>Tradescantia bracteata</i>	38–57	–
	goldenrod	SOLID	<i>Solidago</i>	19–38	–
	scurfpea	PSORA2	<i>Psoralegium</i>	19–38	–
	sunflower	HELIA3	<i>Helianthus</i>	19–38	–
	hairy false goldenaster	HEVI4	<i>Heterotheca villosa</i>	19–38	–
	blazing star	LIATR	<i>Liatris</i>	19–38	–
	rush skeletonplant	LYJU	<i>Lygodesmia juncea</i>	19–38	–
	Cuman ragweed	AMPS	<i>Ambrosia psilostachya</i>	19–38	–
	prairie clover	DALEA	<i>Dalea</i>	19–38	–
	silky prairie clover	DAVI	<i>Dalea villosa</i>	19–38	–
	smooth horsetail	EQLA	<i>Equisetum laevigatum</i>	19–38	–
	sanddune wallflower	ERCAC	<i>Erysimum capitatum var. capitatum</i>	0–19	–
	blacksamson echinacea	ECAN2	<i>Echinacea angustifolia</i>	0–19	–
	milkvetch	ASTRA	<i>Astragalus</i>	0–19	–
	wavyleaf thistle	CIUN	<i>Cirsium undulatum</i>	0–19	–
	large Indian breadroot	PEES	<i>Pediomelum esculentum</i>	0–19	–
	upright prairie coneflower	RACO3	<i>Ratibida columnifera</i>	0–19	–
Shrub/Vine					
9	Shrubs			38–95	
	leadplant	AMCA6	<i>Amorpha canescens</i>	38–57	–
	soapweed yucca	YUGL	<i>Yucca glauca</i>	0–57	–
	rose	ROSA5	<i>Rosa</i>	19–38	–
	prairie sagewort	ARFR4	<i>Artemisia frigida</i>	19–38	–
	spiny star	ESVIV	<i>Escobaria vivipara var. vivipara</i>	0–19	–
	western sandcherry	PRPUB	<i>Prunus pumila var. besseyi</i>	0–19	–
	dwarf false indigo	AMNA	<i>Amorpha nana</i>	0–19	–
	Subshrub (<.5m)	2SUBS	<i>Subshrub (<.5m)</i>	0–19	–

Table 10. Community 2.1 plant community composition

Group	Common Name	Symbol	Scientific Name	Annual Production (Kg/Hectare)	Foliar Cover (%)
Grass/Grasslike					
1	Bluestem			0–18	

	little bluestem	SCSC	<i>Schizachyrium scoparium</i>	0–18	–
	sand bluestem	ANHA	<i>Andropogon hallii</i>	0–9	–
2	Other Native Tall Grasses			0–45	
	prairie sandreed	CALO	<i>Calamovilfa longifolia</i>	0–45	–
3	Needlegrass			90–224	
	needle and thread	HECOC8	<i>Hesperostipa comata</i> ssp. <i>comata</i>	90–224	–
	porcupinegrass	HESP11	<i>Hesperostipa spartea</i>	0–45	–
4	Gramma			45–81	
	blue grama	BOGR2	<i>Bouteloua gracilis</i>	27–72	–
	hairy grama	BOHI2	<i>Bouteloua hirsuta</i>	9–36	–
5	Other Native Grasses			18–63	
	Scribner's rosette grass	DIOLS	<i>Dichanthelium oligosanthes</i> var. <i>scribnerianum</i>	9–45	–
	sand dropseed	SPCR	<i>Sporobolus cryptandrus</i>	9–45	–
	Grass, perennial	2GP	<i>Grass, perennial</i>	0–27	–
	prairie Junegrass	KOMA	<i>Koeleria macrantha</i>	9–18	–
	western wheatgrass	PASM	<i>Pascopyrum smithii</i>	0–9	–
	mat sandbur	CELO3	<i>Cenchrus longispinus</i>	0–9	–
6	Grass-Likes			90–224	
	threadleaf sedge	CAFI	<i>Carex filifolia</i>	90–224	–
	Grass-like (not a true grass)	2GL	<i>Grass-like (not a true grass)</i>	0–45	–
	Pennsylvania sedge	CAPE6	<i>Carex pensylvanica</i>	0–27	–
7	Non-Native Grasses			0–45	
	Kentucky bluegrass	POPR	<i>Poa pratensis</i>	0–45	–
	cheatgrass	BRTE	<i>Bromus tectorum</i>	0–27	–
	smooth brome	BRIN2	<i>Bromus inermis</i>	0–9	–
Forb					
8	Forbs			45–135	
	sweetclover	MELIL	<i>Melilotus</i>	0–90	–
	Forb, annual	2FA	<i>Forb, annual</i>	9–45	–
	Forb, perennial	2FP	<i>Forb, perennial</i>	9–45	–
	tarragon	ARDR4	<i>Artemisia dracunculus</i>	9–45	–
	Cuman ragweed	AMPS	<i>Ambrosia psilostachya</i>	9–36	–
	sunflower	HELIA3	<i>Helianthus</i>	9–36	–
	scurfpea	PSORA2	<i>Psoralegium</i>	9–27	–
	upright prairie coneflower	RACO3	<i>Ratibida columnifera</i>	9–18	–
	goldenrod	SOLID	<i>Solidago</i>	9–18	–
	beardtongue	PENST	<i>Penstemon</i>	9–18	–
	hairy false goldenaster	HEVI4	<i>Heterotheca villosa</i>	0–18	–
	blazing star	LIATR	<i>Liatris</i>	9–18	–
	rush skeletonplant	LYJU	<i>Lygodesmia juncea</i>	9–18	–
	wavyleaf thistle	CIUN	<i>Cirsium undulatum</i>	0–18	–
	prairie clover	DALEA	<i>Dalea</i>	9–18	–

	smooth horsetail	EQLA	<i>Equisetum laevigatum</i>	9–18	–
	sanddune wallflower	ERCAC	<i>Erysimum capitatum var. capitatum</i>	0–9	–
	blacksamson echinacea	ECAN2	<i>Echinacea angustifolia</i>	0–9	–
	milkvetch	ASTRA	<i>Astragalus</i>	0–9	–
Shrub/Vine					
9	Shrubs			18–63	
	prairie sagewort	ARFR4	<i>Artemisia frigida</i>	9–45	–
	rose	ROSA5	<i>Rosa</i>	9–27	–
	soapweed yucca	YUGL	<i>Yucca glauca</i>	0–27	–
	dwarf false indigo	AMNA	<i>Amorpha nana</i>	0–18	–
	spiny star	ESVIV	<i>Escobaria vivipara var. vivipara</i>	0–9	–
	Subshrub (<.5m)	2SUBS	<i>Subshrub (<.5m)</i>	0–9	–
	leadplant	AMCA6	<i>Amorpha canescens</i>	0–9	–

Table 11. Community 3.1 plant community composition

Group	Common Name	Symbol	Scientific Name	Annual Production (Kg/Hectare)	Foliar Cover (%)
Grass/Grasslike					
3	Needlegrass			28–56	
	needle and thread	HECOC8	<i>Hesperostipa comata ssp. comata</i>	28–56	–
4	Gramma			6–28	
	blue grama	BOGR2	<i>Bouteloua gracilis</i>	6–28	–
	hairy grama	BOHI2	<i>Bouteloua hirsuta</i>	0–22	–
5	Other Native Grasses			17–56	
	sand dropseed	SPCR	<i>Sporobolus cryptandrus</i>	11–45	–
	Grass, perennial	2GP	<i>Grass, perennial</i>	0–17	–
	mat sandbur	CELO3	<i>Cenchrus longispinus</i>	6–17	–
	Scribner's rosette grass	DIOLS	<i>Dichanthelium oligosanthes var. scribnerianum</i>	6–11	–
	prairie Junegrass	KOMA	<i>Koeleria macrantha</i>	0–6	–
6	Grass-Likes			56–196	
	threadleaf sedge	CAFI	<i>Carex filifolia</i>	56–196	–
	Grass-like (not a true grass)	2GL	<i>Grass-like (not a true grass)</i>	0–56	–
7	Non-Native Grasses			0–17	
	cheatgrass	BRTE	<i>Bromus tectorum</i>	0–17	–
Forb					
8	Forbs			56–140	
	sweetclover	MELIL	<i>Melilotus</i>	0–84	–
	Forb, annual	2FA	<i>Forb, annual</i>	6–45	–
	Forb, perennial	2FP	<i>Forb, perennial</i>	6–45	–
	tarragon	ARDR4	<i>Artemisia dracunculus</i>	6–45	–
	Cuman ragweed	AMPS	<i>Ambrosia psilostachya</i>	6–28	–
	sunflower	HELIA3	<i>Helianthus</i>	0–22	–

	scurfpea	PSORA2	<i>Psoraleidium</i>	6–22	–
	wavyleaf thistle	CIUN	<i>Cirsium undulatum</i>	0–11	–
	prairie clover	DALEA	<i>Dalea</i>	6–11	–
	smooth horsetail	EQLA	<i>Equisetum laevigatum</i>	6–11	–
	goldenrod	SOLID	<i>Solidago</i>	0–11	–
	blazing star	LIATR	<i>Liatris</i>	0–6	–
	rush skeletonplant	LYJU	<i>Lygodesmia juncea</i>	0–6	–
	milkvetch	ASTRA	<i>Astragalus</i>	0–6	–
	upright prairie coneflower	RACO3	<i>Ratibida columnifera</i>	0–6	–
Shrub/Vine					
9	Shrubs			28–67	
	prairie sagewort	ARFR4	<i>Artemisia frigida</i>	6–45	–
	rose	ROSA5	<i>Rosa</i>	6–34	–
	soapweed yucca	YUGL	<i>Yucca glauca</i>	0–28	–
	Subshrub (<.5m)	2SUBS	<i>Subshrub (<.5m)</i>	0–11	–
	spiny star	ESVIV	<i>Escobaria vivipara var. vivipara</i>	0–6	–

Table 12. Community 4.1 plant community composition

Group	Common Name	Symbol	Scientific Name	Annual Production (Kg/Hectare)	Foliar Cover (%)
Grass/Grasslike					
1	Bluestem			31–157	
	sand bluestem	ANHA	<i>Andropogon hallii</i>	31–157	–
	little bluestem	SCSC	<i>Schizachyrium scoparium</i>	0–110	–
3	Needlegrass			78–235	
	needle and thread	HECOC8	<i>Hesperostipa comata ssp. comata</i>	78–235	–
	porcupinegrass	HESP11	<i>Hesperostipa spartea</i>	0–78	–
4	Gramma			0–47	
	blue grama	BOGR2	<i>Bouteloua gracilis</i>	0–47	–
	hairy grama	BOHI2	<i>Bouteloua hirsuta</i>	0–47	–
5	Other Native Grasses			47–110	
	sand dropseed	SPCR	<i>Sporobolus cryptandrus</i>	16–78	–
	western wheatgrass	PASM	<i>Pascopyrum smithii</i>	0–47	–
	Grass, perennial	2GP	<i>Grass, perennial</i>	0–47	–
	mat sandbur	CELO3	<i>Cenchrus longispinus</i>	0–31	–
	Scribner's rosette grass	DIOLS	<i>Dichanthelium oligosanthes var. scribnerianum</i>	16–31	–
	prairie Junegrass	KOMA	<i>Koeleria macrantha</i>	16–31	–
	Canada wildrye	ELCA4	<i>Elymus canadensis</i>	0–16	–
6	Grass-Likes			78–235	
	threadleaf sedge	CAFI	<i>Carex filifolia</i>	78–235	–
	Grass-like (not a true grass)	2GL	<i>Grass-like (not a true grass)</i>	0–78	–
	Pennsylvania sedge	CAPE6	<i>Carex pensylvanica</i>	0–63	–
7	Non-Native Grasses			78–235	

	Kentucky bluegrass	POPR	<i>Poa pratensis</i>	31–235	–
	smooth brome	BRIN2	<i>Bromus inermis</i>	0–188	–
	cheatgrass	BRTE	<i>Bromus tectorum</i>	0–78	–
Shrub/Vine					
2	Other Native Tall Grasses			47–157	
	prairie sandreed	CALO	<i>Calamovilfa longifolia</i>	47–157	–
9	Shrubs			78–157	
	prairie sagewort	ARFR4	<i>Artemisia frigida</i>	16–78	–
	soapweed yucca	YUGL	<i>Yucca glauca</i>	0–63	–
	rose	ROSA5	<i>Rosa</i>	16–47	–
	Subshrub (<.5m)	2SUBS	<i>Subshrub (<.5m)</i>	0–47	–
	dwarf false indigo	AMNA	<i>Amorpha nana</i>	0–31	–
	leadplant	AMCA6	<i>Amorpha canescens</i>	0–16	–
	spiny star	ESVIV	<i>Escobaria vivipara var. vivipara</i>	0–16	–
Forb					
8	Forbs			157–235	
	sweetclover	MELIL	<i>Melilotus</i>	0–157	–
	Forb, annual	2FA	<i>Forb, annual</i>	16–78	–
	Forb, perennial	2FP	<i>Forb, perennial</i>	16–78	–
	Cuman ragweed	AMPS	<i>Ambrosia psilostachya</i>	16–63	–
	tarragon	ARDR4	<i>Artemisia dracunculus</i>	16–63	–
	goldenrod	SOLID	<i>Solidago</i>	16–63	–
	sunflower	HELIA3	<i>Helianthus</i>	16–47	–
	hairy false goldenaster	HEVI4	<i>Heterotheca villosa</i>	0–31	–
	blazing star	LIATR	<i>Liatris</i>	0–31	–
	smooth horsetail	EQLA	<i>Equisetum laevigatum</i>	16–31	–
	wavyleaf thistle	CIUN	<i>Cirsium undulatum</i>	0–31	–
	prairie clover	DALEA	<i>Dalea</i>	16–31	–
	beardtongue	PENST	<i>Penstemon</i>	16–31	–
	scurfpea	PSORA2	<i>Psoralegium</i>	16–31	–
	upright prairie coneflower	RACO3	<i>Ratibida columnifera</i>	16–31	–
	longbract spiderwort	TRBR	<i>Tradescantia bracteata</i>	0–16	–
	silky prairie clover	DAVI	<i>Dalea villosa</i>	0–16	–
	blacksamson echinacea	ECAN2	<i>Echinacea angustifolia</i>	0–16	–
	milkvetch	ASTRA	<i>Astragalus</i>	0–16	–
	sanddune wallflower	ERCAC	<i>Erysimum capitatum var. capitatum</i>	0–16	–
	rush skeletonplant	LYJU	<i>Lygodesmia juncea</i>	0–16	–

Animal community

Wildlife Interpretations:
Under development.

Grazing Interpretations:

This site is well adapted to managed grazing by domestic livestock. The predominance of herbaceous plants across all plant community phases best lends these sites to grazing by cattle but other domestic grazers with differing diet preferences may also be a consideration depending upon management objectives. Often, the current plant community does not entirely match any particular plant community (as described in the ecological site description). Because of this, a resource inventory is necessary to document plant composition and production. Proper interpretation of this inventory data will permit the establishment of a safe, initial stocking rate for the type and class of animals and level of grazing management. More accurate stocking rate estimates should eventually be calculated using actual stocking rate information and monitoring data.

Hydrological functions

Water is the principal factor limiting herbage production on this site. The site is dominated by soils in hydrologic group A. Infiltration varies from rapid to very rapid and runoff potential varies from negligible to very low depending on soil hydrologic group and ground cover. In many cases, areas with greater than 75% ground cover have the greatest potential for high infiltration and lower runoff. Areas where ground cover is less than 50% have the greatest potential to have reduced infiltration and higher runoff (refer to Section 4, NRCS National Engineering Handbook for runoff quantities and hydrologic curves).

Recreational uses

This site provides hunting opportunities for upland game species. The wide variety of plants which bloom from spring until fall have an esthetic value that appeals to visitors.

Wood products

No appreciable wood products are present on the site.

Other products

Seed harvest of native plant species can provide additional income on this site.

Inventory data references

Information presented here has been derived from NRCS clipping and other inventory data. Also, field knowledge of range-trained personnel was used. All descriptions were peer reviewed and/or field-tested by various private, state and federal agency specialists. Those involved in developing this site description include: Stan Boltz, NRCS Range Management Specialist; Michael D. Brand, State Land Dept., Director Surface Management; David Dewald, NRCS State Biologist; Paul Drayton, NRCS District Conservationist; Jody Forman, NRCS Range Management Specialist; Dennis Froemke, NRCS Range Management Specialist; Jeff Printz, NRCS State Range Management Specialist; Josh Saunders, NRCS Range Management Specialist; Kevin Sedivec, Extension Rangeland Management Specialist; Darrell Vanderbusch, NRCS Resource Soil Scientist; and Lee Voigt, NRCS Range Management Specialist.

Other references

High Plains Regional Climate Center, University of Nebraska, 830728 Chase Hall, Lincoln, NE 68583-0728.

(<http://hprcc.unl.edu>)

USDA, NRCS. National Water and Climate Center, 101 SW Main, Suite 1600, Portland, OR 97204-3224.

(<http://www.wcc.nrcs.usda.gov>)

USDA, NRCS. National Range and Pasture Handbook, September 1997

USDA, NRCS. National Soil Information System, Information Technology Center, 2150 Centre Avenue, Building A, Fort Collins, CO 80526. (<http://nasis.nrcs.usda.gov>)

USDA, NRCS. 2001. The PLANTS Database, Version 3.1 (<http://plants.usda.gov>). National Plant Data Center, Baton Rouge, LA 70874-4490 USA.

USDA, NRCS, Various Published Soil Surveys.

Contributors

Jeff Printz
Jeff Printz/Stan Boltz

Approval

Suzanne Mayne-Kinney, 1/11/2024

Rangeland health reference sheet

Interpreting Indicators of Rangeland Health is a qualitative assessment protocol used to determine ecosystem condition based on benchmark characteristics described in the Reference Sheet. A suite of 17 (or more) indicators are typically considered in an assessment. The ecological site(s) representative of an assessment location must be known prior to applying the protocol and must be verified based on soils and climate. Current plant community cannot be used to identify the ecological site.

Author(s)/participant(s)	Jeff Printz, Stan Boltz, Lee Voigt, Jody Forman
Contact for lead author	Jeff.printz@nd.usda.gov 701-530-2080
Date	03/02/2012
Approved by	Suzanne Mayne-Kinney
Approval date	
Composition (Indicators 10 and 12) based on	Annual Production

Indicators

1. **Number and extent of rills:** None.

2. **Presence of water flow patterns:** None.

3. **Number and height of erosional pedestals or terracettes:** Some pedestalling of bunchgrasses may be observable but roots will not be exposed.

4. **Bare ground from Ecological Site Description or other studies (rock, litter, lichen, moss, plant canopy are not bare ground):** Bare ground is 15 to 20%. Patch size is 6 inches or less and not connected.

5. **Number of gullies and erosion associated with gullies:** None.

6. **Extent of wind scoured, blowouts and/or depositional areas:** Occasional small (< a few feet across) areas of blowouts/wind scoured areas with associated depositional areas associated with increased animal activity (i.e. rodent burrows, animal trailing). The areas may increase in number and size following prolonged drought.

7. **Amount of litter movement (describe size and distance expected to travel):** Slight movement of small sized litter

may be observable on slopes greater than 20%.

8. **Soil surface (top few mm) resistance to erosion (stability values are averages - most sites will show a range of values):** Stability averages 5 or greater.
-

9. **Soil surface structure and SOM content (include type of structure and A-horizon color and thickness):** Use soil series description for depth, color and structure of A horizon/surface layer.
-

10. **Effect of community phase composition (relative proportion of different functional groups) and spatial distribution on infiltration and runoff:** Combination of shallow and deep rooted species (mid & tall rhizomatous and tufted perennial cool- and warm-season grasses) with fine and coarse roots positively influences infiltration.
-

11. **Presence and thickness of compaction layer (usually none; describe soil profile features which may be mistaken for compaction on this site):** None. Buried A horizon may be present but does not constitute a compaction layer.
-

12. **Functional/Structural Groups (list in order of descending dominance by above-ground annual-production or live foliar cover using symbols: >>, >, = to indicate much greater than, greater than, and equal to):**

Dominant: Tall, warm-season rhizomatous grasses >

Sub-dominant: Mid, cool-season bunchgrasses >

Other: Grass-likes = forbs > short, warm-season grasses = mid, cool-season rhizomatous grasses = shrubs > short, cool-season grasses

Additional: Due to differing root structure and distribution, Kentucky bluegrass and smooth brome grass do not fit into reference plant community F/S groups.

13. **Amount of plant mortality and decadence (include which functional groups are expected to show mortality or decadence):** None.
-

14. **Average percent litter cover (%) and depth (in):** Plant litter is in contact with soil surface.
-

15. **Expected annual annual-production (this is TOTAL above-ground annual-production, not just forage annual-production):** Representative value = 1700 lbs./ac air dry with a range of 1100 to 2300 lbs./ac air dry depending upon growing conditions.
-

16. **Potential invasive (including noxious) species (native and non-native). List species which BOTH characterize degraded states and have the potential to become a dominant or co-dominant species on the ecological site if their future establishment and growth is not actively controlled by management interventions. Species that**

become dominant for only one to several years (e.g., short-term response to drought or wildfire) are not invasive plants. Note that unlike other indicators, we are describing what is **NOT** expected in the reference state for the ecological site: State and local noxious weeds, Kentucky bluegrass, smooth brome grass

17. **Perennial plant reproductive capability:** All species exhibit high vigor relative to climatic conditions. Do not rate based solely on seed production. Perennial grasses should have vigorous rhizomes or tillers.
-