

Ecological site R054XY042ND Sandy Terrace

Accessed: 02/07/2025

General information

Provisional. A provisional ecological site description has undergone quality control and quality assurance review. It contains a working state and transition model and enough information to identify the ecological site.

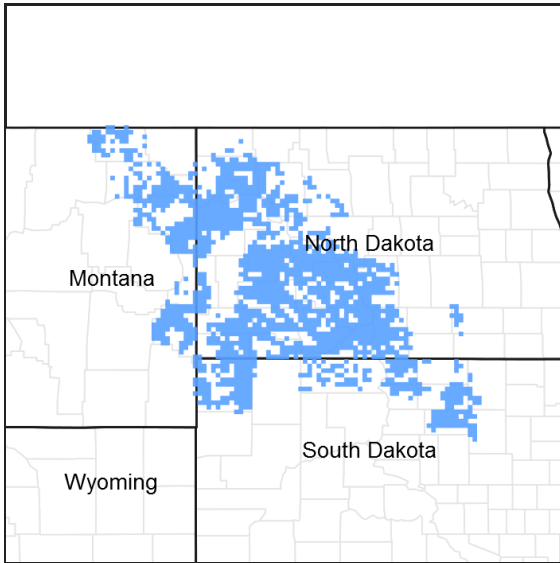

Figure 1. Mapped extent

Areas shown in blue indicate the maximum mapped extent of this ecological site. Other ecological sites likely occur within the highlighted areas. It is also possible for this ecological site to occur outside of highlighted areas if detailed soil survey has not been completed or recently updated.

Classification relationships

Level IV Ecoregions of the Conterminous United States: 43a – Missouri Plateau.

Associated sites

R054XY023ND	Loamy Overflow
R054XY025ND	Sands
R054XY026ND	Sandy
R054XY034ND	Choppy Sands
R054XY041ND	Loamy Terrace

Similar sites

R054XY023ND	<p>Loamy Overflow [Moderately well drained soils in intermittent drainage ways, swales and areas that frequently receive additional moisture throughout the growing season, with no apparent water table. Indicator species: big bluestem with western wheatgrass and green needlegrass, American licorice, and western snowberry. This site has no prairie sandreed and sand bluestem, far more big bluestem, frequent flooding events, more production.]</p>
-------------	---

R054XY026ND	<p>Sandy [Does not receive additional moisture. Found on dry uplands upslope from sandy terraces or loamy overflow sites, down slope from limy sands or shallow sandy sites. Similar landscape position as loamy, sands, clayey sites; will ribbon up to 1 inches. Indicator species are prairie sandreed with western wheatgrass and green needlegrass intermixed. This site has less production, different landscape position and no potential to flood, similar species composition with less silver sagebrush and/or western snowberry and sporadic trees.]</p>
R054XY041ND	<p>Loamy Terrace [Well drained soils on a river or stream terrace in a position that will flood occasionally (once in ten years) with no apparent water table. Down slope from loamy, sandy, clayey, and sands, and upslope form subirrigated ecological sites. Indicator species are western wheatgrass evenly mixed with green needlegrass, American vetch, and western snowberry or silver sagebrush, and with possible trees. This site has no prairie sandreed, sand bluestem, less sedges and shrubs, more green needlegrass, western wheatgrass, blue grama, similar production, and landscape position.]</p>
R054XY034ND	<p>Choppy Sands [Deep entisol found on knobs and ridges of level to choppy sand blown plains; will not ribbon, found upslope from sands and sandy terrace sites; won't ribbon. Indicator species: Sand bluestem, prairie sandreed and needleandthread evenly mixed, some Canada wildrye, penstemon, lemon scurfpea western ragweed, yucca, silky prairie clover and leadplant. This site has less production, thin "A" horizon and has a non-mollic epipedon, more little bluestem, less prairie sandreed, green needlegrass and shrubs, no trees, can be in the same landscape positions, but has very little potential to receive additional moisture through occasional flooding.]</p>
R054XY027ND	<p>Sandy Claypan [Well drained soils on uplands and terraces that don't receive extra moisture with a dense sodic subsoil below 6 inches with salts below 16 inches. Subsoil will ribbon up to 1 inch. Indicator species are western wheatgrass intermixed with areas of prairie sandreed both dominating with an understory of needleandthread and blue grama, heath aster, cudweed sagewort and western yarrow along with fringed sagewort. This site has dense sodic subsoil below 6 inches with salts below 16 inches, far more western wheatgrass, blue grama, less prairie sandreed, and sand bluestem, with less silver sagebrush and/or western snowberry and no sporadic trees, less production.]</p>

Table 1. Dominant plant species

Tree	Not specified
Shrub	Not specified
Herbaceous	(1) <i>Calamovilfa longifolia</i>

Physiographic features

This soil occurs on level to nearly level occasionally flooded floodplains and terraces.

Table 2. Representative physiographic features

Landforms	(1) Flood plain (2) Terrace (3) Natural levee
Flooding duration	Very brief (4 to 48 hours) to brief (2 to 7 days)
Flooding frequency	Rare to occasional
Ponding frequency	None
Elevation	1,600–3,600 ft
Slope	0–6%
Ponding depth	0 in
Water table depth	54–72 in
Aspect	Aspect is not a significant factor

Climatic features

MLRA 54 is considered to have a continental climate – cold winters and hot summers, low humidity, light rainfall, and much sunshine. Extremes in temperature are characteristic. The climate is the result of this MLRA's location in the geographic center of North America. There are few natural barriers on the northern Great Plains. The air masses move unobstructed across the plains and account for rapid changes in temperature.

Annual precipitation ranges from 14 to 18 inches per year. The normal average annual temperature is about 42° F. January is the coldest month with average temperatures ranging from about 13° F (Beach, ND) to about 16° F (Bison, SD). July is the warmest month with temperatures averaging from about 69° F (Beach, ND) to about 72° F (Timber Lake, SD). The range of normal average monthly temperatures between the coldest and warmest months is about 57° F. This large annual range attests to the continental nature of this MLRA's climate. Hourly winds are estimated to average about 11 miles per hour annually, ranging from about 13 miles per hour during the spring to about 10 miles per hour during the summer. Daytime winds are generally stronger than nighttime and occasional strong storms may bring brief periods of high winds with gusts to more than 50 miles per hour.

Growth of native cool-season plants begins in late March and continues to early to mid July. Native warm-season plants begin growth in mid May and continue to the end of August. Green up of cool-season plants can occur in September and October when adequate soil moisture is present.

Table 3. Representative climatic features

Frost-free period (average)	136 days
Freeze-free period (average)	157 days
Precipitation total (average)	18 in

Influencing water features

C6

(Rosgen System)

Soil features

The common features of soils in this site are the fine sandy loam to sandy loam-textured subsoils and slopes of 1 to 6 percent. The soils in this site are well to somewhat excessively drained and formed from alluvium. The loamy fine sand to loam surface layer is 3 to 7 inches thick. The soils have a rapid to moderately rapid infiltration rate. This site should show no evidence of rills, wind scoured areas or pedestalled plants. Water flow paths are broken, irregular in appearance or discontinuous with numerous debris dams or vegetative barriers. The soil surface is stable and intact. Sub-surface soil layers are non-restrictive to water movement and root penetration.

These soils are susceptible to water and wind erosion. The hazard of water and wind erosion increases where vegetative cover is not adequate. Loss of the soil surface layer can result in a shift in species composition and/or production.

Major soil series correlated to this ecological site can be found in Section II of the Natural Resources Conservation Service Field Office Technical Guide or the following web sites:

North Dakota <http://www.nd.nrcs.usda.gov/>

South Dakota <http://www.sd.nrcs.usda.gov/>

Montana <http://www.mt.nrcs.usda.gov/>

Table 4. Representative soil features

Surface texture	(1) Fine sandy loam (2) Loamy fine sand (3) Loam
Family particle size	(1) Loamy

Drainage class	Well drained to somewhat excessively drained
Permeability class	Moderately rapid to rapid
Soil depth	72 in
Surface fragment cover <=3"	0%
Surface fragment cover >3"	0%
Available water capacity (0-40in)	4-6 in
Calcium carbonate equivalent (0-40in)	5-25%
Electrical conductivity (0-40in)	0-4 mmhos/cm
Sodium adsorption ratio (0-40in)	0-2
Soil reaction (1:1 water) (0-40in)	6.1-8.4
Subsurface fragment volume <=3" (Depth not specified)	0-10%
Subsurface fragment volume >3" (Depth not specified)	0-5%

Ecological dynamics

The site developed under Northern Great Plains climatic conditions, and included natural influence of large herbivores and occasional fire. Changes will occur in the plant communities due to climatic conditions and/or management actions. Due to the nature of the soils, the site is considered very stable. Under continued adverse impacts, a slow decline in vegetative vigor and composition will occur. Under favorable vegetative management treatments the site can quickly return to the Historic Climax Plant Community (HCPC).

The plant community upon which interpretations are primarily based is the Historic Climax Plant Community. The HCPC has been determined by study of rangeland relic areas, areas protected from excessive disturbance, and areas under long-term rotational grazing regimes. Trends in plant community dynamics ranging from heavily grazed to lightly grazed areas, seasonal use pastures, and historical accounts also have been considered. Subclimax plant communities, states, transitional pathways, and thresholds have been determined through similar studies and experience.

Continuous grazing without adequate recovery periods following each grazing occurrence over several years causes this site to depart from the HCPC. Species such as needleandthread, red threeawn, blue grama and sedges will initially increase while sand bluestem and/or big bluestem, and sideoats grama have disappeared and prairie sandreed and green needlegrass have decrease in frequency and production. Heavy continuous grazing causes blue grama, sedges and forbs to increase.

In time, heavy continuous grazing will likely cause upland sedges and blue grama to dominate and pioneer perennials, annuals, and club moss (in its range) to increase. This plant community is relatively stable and the competitive advantage prevents other species from establishing. This plant community is less productive than the HCPC. Runoff increases and infiltration will decrease. Soil erosion will be minimal. Under extended periods of non-use and/or lack of fire will result in a plant community having high litter levels, which favors an increase in Kentucky bluegrass and/or smooth brome grass. In time, shrubs and trees such as western snowberry, chokecherry and green ash will likely increase.

The following is a diagram that illustrates the common plant communities that can occur on the site and the transition pathways between communities. The ecological processes will be discussed in more detail in the plant community descriptions following the diagram.

State and transition model

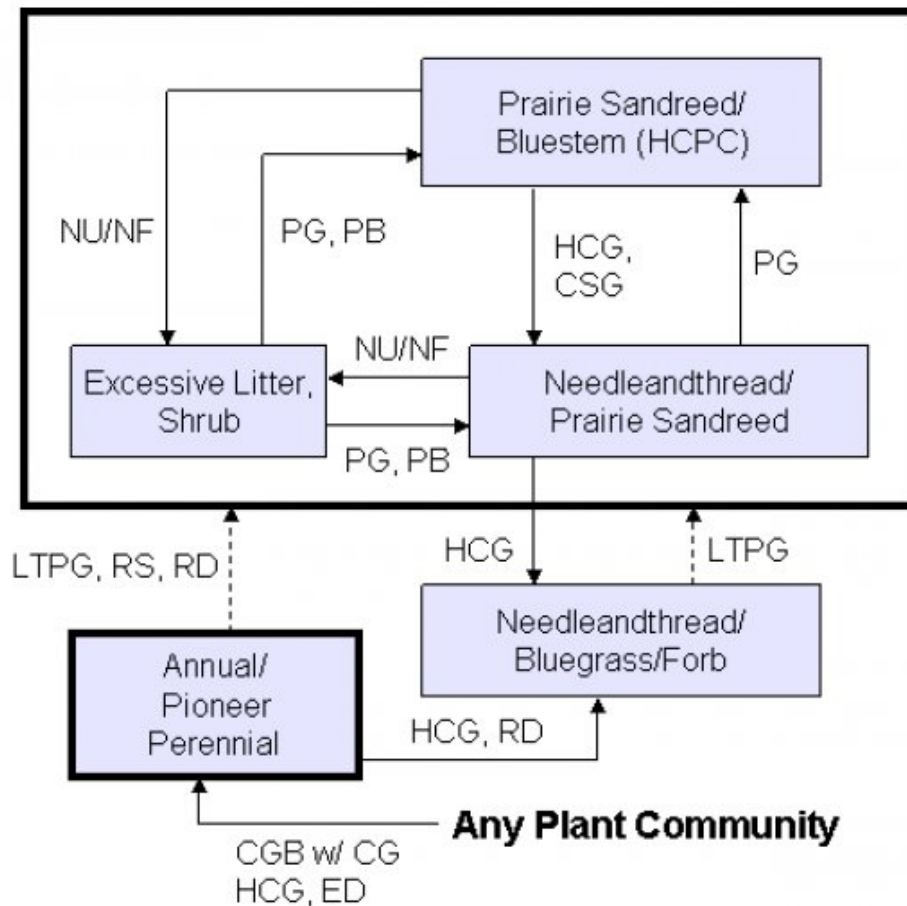

CGB w/ CG - cropped go-back with continuous grazing; **CSG** - continuous seasonal grazing; **ED** - excessive defoliation; **F** - fertilization followed with prescribed grazing; **HCG** - heavy continuous grazing; **HCPC** - Historical Climax Plant Community; **LTPG** - long-term prescribed grazing; **NU/NF** - extended period of non-use & no fire; **PB** - prescribed burning followed by prescribed grazing; **PG** - prescribed grazing; **RD** - removal of disturbance; **RS** - range seeding with prescribed grazing.

State 1
Prairie Sandreed/Bluestem (HCPC)

Community 1.1 Prairie Sandreed/Bluestem (HCPC)

This is the interpretive plant community and is considered to be the Historic Climax Plant Community (HCPC). This community evolved with grazing by large herbivores and occasional prairie fire. It is well suited for grazing by domestic livestock and can be found on areas that are properly managed with prescribed grazing that allows for adequate recovery periods following each grazing event. The potential vegetation is about 73% grasses and grass-like plants, 15% forbs, 10% shrubs, and 2% trees. Major grasses include prairie sandreed, bluestems and needlegrasses. Other grasses occurring on this community include bearded wheatgrass, Canada wildrye, sideoats grama, blue grama, western wheatgrass and sedge. Major forbs and shrubs include American vetch, cudweed sagewort, western yarrow, sunflower, leadplant, western snowberry, chokecherry and fringed sagewort. Scattered green ash, plains cottonwood and American elm may occur. This plant community is well adapted to the Northern Great Plains climatic conditions. Individual species can vary in production depending on growing conditions (timing/amount of precipitation and temperature). Community dynamics, nutrient cycle, water cycle and energy flow are functioning properly. Plant litter is properly distributed with very little movement off-site and natural plant mortality is very low. The diversity in plant species allows for high drought tolerance. Run-off from adjacent sites and moderate or high available water capacity provides a favorable soil-water-plant relationship.

Table 5. Annual production by plant type

Plant Type	Low (Lb/Acre)	Representative Value (Lb/Acre)	High (Lb/Acre)
Grass/Grasslike	1710	2355	3010
Forb	220	375	500
Shrub/Vine	145	225	325
Tree	25	45	65
Total	2100	3000	3900

Figure 5. Plant community growth curve (percent production by month).
ND5403, Missouri Slope, Native Grasslands, Warm-season dominant. Warm-season dominant.

Jan	Feb	Mar	Apr	May	Jun	Jul	Aug	Sep	Oct	Nov	Dec
0	0	1	5	20	38	25	8	3	0	0	0

State 2 Needleandthread/Prairie Sandreed

Community 2.1 Needleandthread/Prairie Sandreed

This plant community can slowly develop from the adverse effects of continuous grazing without adequate recovery periods between each grazing event during the growing season. Recognition of this plant community will enable the land user to implement key management decisions before a significant ecological threshold is crossed.

Needleandthread and prairie sandreed are the dominant species. Prairie sandreed and green needlegrass have been reduced. Big bluestem, sand bluestem, porcupine grass, sideoats grama, spiderwort and prairie clover have greatly reduced. Forb species include green sagewort, cudweed sagewort, prairie coneflower, silverleaf scurfpea, western ragweed and western salsify. Leadplant, western snowberry, chokecherry have been reduced while other woody species would tend to be heavily browsed. Fringed sagewort has increased. This plant community is relatively stable and less productive than the HCPC. Reduction of litter and plant cover results in higher soil temperatures, poor water infiltration rates, increased runoff and high evapo-transpiration rates. This plant community can occur throughout the site, on spot grazed areas, and around water sources where season-long grazing patterns occur. Soil erosion will be minimal.

Table 6. Annual production by plant type

Plant Type	Low (Lb/Acre)	Representative Value (Lb/Acre)	High (Lb/Acre)
Grass/Grasslike	555	790	1025
Forb	95	125	155
Shrub/Vine	45	75	105
Tree	5	10	15
Total	700	1000	1300

Figure 7. Plant community growth curve (percent production by month). ND5402, Missouri Slope, Native Grasslands, Cool/Warm-season Mix. Cool-season/warm-season dominant.

Jan	Feb	Mar	Apr	May	Jun	Jul	Aug	Sep	Oct	Nov	Dec
0	0	2	6	21	40	20	6	4	1	0	0

State 3 Excessive Litter, Shrub

Community 3.1 Excessive Litter, Shrub

This plant community develops after an extended period (10 to 20 years) of non-use or exclusion of fire. Eventually litter levels become high enough to reduce native grass vigor, diversity and density. Kentucky bluegrass, crested wheatgrass and/or smooth brome grass tend to invade and may dominate this plant community. Common forbs include sweetclover, cudweed sagewort, green sagewort, and goldenrod species. Shrubs such as western snowberry, buffaloberry and chokecherry will increase in density and cover and eventually tree species such as green ash will also increase. This plant community is resistant to change without prescribed grazing and/or fire. The combination of both grazing and fire is most effective in moving this it toward the HCPC. Soil erosion is low. Runoff is similar to the HCPC. Once the advanced stage of this plant community is reached, time and external resources will be needed to see any immediate recovery in the diversity of the site.

Table 7. Annual production by plant type

Plant Type	Low (Lb/Acre)	Representative Value (Lb/Acre)	High (Lb/Acre)
Grass/Grasslike	1285	1846	2415
Shrub/Vine	220	325	425
Forb	220	325	425
Tree	75	104	135
Total	1800	2600	3400

Figure 9. Plant community growth curve (percent production by month). ND5406, Missouri Slope, Introduced Cool-season Grasses. Introduced cool-season grasses.

Jan	Feb	Mar	Apr	May	Jun	Jul	Aug	Sep	Oct	Nov	Dec
0	0	3	10	35	35	5	2	8	2	0	0

State 4 Needleandthread/Bluegrass/Forb

Community 4.1 Needleandthread/Bluegrass/Forb

This plant community developed with heavy continuous grazing without adequate recovery periods between grazing

events. It is made up of needleandthread, red threeawn, sand dropseed, sedges and undesirable forbs scattered within a sod of bluegrass. Low vigor western wheatgrass and prairie junegrass can be found scattered throughout the community. At this level of departure from HCPC, green needlegrass has been removed. Green sagewort, scurfpea, curlycup gumweed, ragweed, hairy goldaster, dandelion, wavyleaf thistle and sweetclover have increased. Key shrubs have been severely reduced in vigor or removed completely. Shrubs that have increase are fringed sagewort and cactus. Remnant trees remain with no regeneration apparent. This plant community is resistant to change due to grazing tolerance of red threeawn and bluegrass. A significant amount of production and diversity has been lost when compared to the HCPC. Loss of cool season grasses, tall warm-season grasses, shrub component and nitrogen fixing forbs have negatively impacted energy flow and nutrient cycling. Water infiltration is reduced. Soil loss may be accelerated where concentrated flows occur.

Table 8. Annual production by plant type

Plant Type	Low (Lb/Acre)	Representative Value (Lb/Acre)	High (Lb/Acre)
Grass/Grasslike	270	510	750
Forb	100	133	165
Shrub/Vine	30	53	75
Tree	0	4	10
Total	400	700	1000

Figure 11. Plant community growth curve (percent production by month). ND5408, Missouri Slope, Sedge Dominant. Cool-season, short grasses and grass-likees.

Jan	Feb	Mar	Apr	May	Jun	Jul	Aug	Sep	Oct	Nov	Dec
0	0	3	10	30	25	20	5	5	2	0	0

Additional community tables

Table 9. Community 1.1 plant community composition

Group	Common Name	Symbol	Scientific Name	Annual Production (Lb/Acre)	Foliar Cover (%)
Grass/Grasslike					
1	Prairie Sandreed			450–600	
	prairie sandreed	CALO	<i>Calamovilfa longifolia</i>	450–600	–
2	Bluestem			300–450	
	sand bluestem	ANHA	<i>Andropogon hallii</i>	150–300	–
	big bluestem	ANGE	<i>Andropogon gerardii</i>	0–150	–
	little bluestem	SCSC	<i>Schizachyrium scoparium</i>	0–60	–
3	Needlegrass			150–300	
	needle and thread	HECOC8	<i>Hesperostipa comata ssp. comata</i>	150–210	–
	green needlegrass	NAVI4	<i>Nassella viridula</i>	60–150	–
	porcupinegrass	HESP11	<i>Hesperostipa spartea</i>	30–60	–
4	Grama			90–150	
	blue grama	BOGR2	<i>Bouteloua gracilis</i>	30–90	–
	hairy grama	BOHI2	<i>Bouteloua hirsuta</i>	0–60	–
5	Other Native Grasses			150–450	
	western wheatgrass	PASM	<i>Pascopyrum smithii</i>	150–210	–
	prairie Junegrass	KOMA	<i>Koeleria macrantha</i>	30–60	–
	sideoats grama	BOCU	<i>Bouteloua curtipendula</i>	0–60	–
	Cocksfoot	FLCO4	<i>Elymus canadensis</i>	30–60	–

	Canada wildrye	ELCA4	<i>Elymus canadensis</i>	30-60	-
	Grass, perennial	2GP	<i>Grass, perennial</i>	0-60	-
	Fendler threeawn	ARPUL	<i>Aristida purpurea</i> var. <i>longiseta</i>	0-30	-
	slender wheatgrass	ELTRS	<i>Elymus trachycaulus</i> ssp. <i>subsecundus</i>	0-30	-
	Scribner's rosette grass	DIOLS	<i>Dichanthelium oligosanthes</i> var. <i>scribnerianum</i>	0-30	-
	plains muhly	MUCU3	<i>Muhlenbergia cuspidata</i>	0-30	-
	sand dropseed	SPCR	<i>Sporobolus cryptandrus</i>	0-30	-
6	Grass-Likes			120-240	
	threadleaf sedge	CAFI	<i>Carex filifolia</i>	60-150	-
	sun sedge	CAINH2	<i>Carex inops</i> ssp. <i>heliophila</i>	60-90	-
	Pennsylvania sedge	CAPE6	<i>Carex pensylvanica</i>	30-60	-
	Grass-like (not a true grass)	2GL	<i>Grass-like (not a true grass)</i>	30	-
Forb					
8	Forbs			300-450	
	goldenrod	SOLID	<i>Solidago</i>	60-90	-
	beardtongue	PENST	<i>Penstemon</i>	60-90	-
	stiff sunflower	HEPA19	<i>Helianthus pauciflorus</i>	30-60	-
	hairy false goldenaster	HEVI4	<i>Heterotheca villosa</i>	30-60	-
	blazing star	LIATR	<i>Liatris</i>	30-60	-
	tarragon	ARDR4	<i>Artemisia dracunculus</i>	30-60	-
	white sagebrush	ARLU	<i>Artemisia ludoviciana</i>	30-60	-
	prairie clover	DALEA	<i>Dalea</i>	30-60	-
	scurfpea	PSORA2	<i>Psoralegium</i>	30-60	-
	American vetch	VIAM	<i>Vicia americana</i>	30-60	-
	upright prairie coneflower	RACO3	<i>Ratibida columnifera</i>	30	-
	scarlet globemallow	SPCO	<i>Sphaeralcea coccinea</i>	30	-
	spiderwort	TRADE	<i>Tradescantia</i>	30	-
	blacksamson echinacea	ECAN2	<i>Echinacea angustifolia</i>	0-30	-
	sanddune wallflower	ERCAC	<i>Erysimum capitatum</i> var. <i>capitatum</i>	30	-
	scarlet beeblossom	GACO5	<i>Gaura coccinea</i>	30	-
	groundplum milkvetch	ASCR2	<i>Astragalus crassicaarpus</i>	30	-
	wavyleaf thistle	CIUN	<i>Cirsium undulatum</i>	30	-
	rush skeletonplant	LYJU	<i>Lygodesmia juncea</i>	0-30	-
	spiny phlox	PHHO	<i>Phlox hoodii</i>	0-30	-
	cinquefoil	POTEN	<i>Potentilla</i>	0-30	-
	Forb, perennial	2FP	<i>Forb, perennial</i>	0-30	-
	common yarrow	ACMI2	<i>Achillea millefolium</i>	30	-
Shrub/Vine					
9	Shrubs			150-300	
	leadplant	AMCA6	<i>Amorpha canescens</i>	60-90	-
	western snowberry	SYOC	<i>Symphoricarpos occidentalis</i>	60-90	-
	rose	ROSA5	<i>Rosa</i>	30-60	-

	silver buffaloberry	SHAR	<i>Shepherdia argentea</i>	30–60	–
	prairie sagewort	ARFR4	<i>Artemisia frigida</i>	30–60	–
	creeping juniper	JUHO2	<i>Juniperus horizontalis</i>	0–30	–
	pricklypear	OPUNT	<i>Opuntia</i>	30	–
	chokecherry	PRVI	<i>Prunus virginiana</i>	30	–
	skunkbush sumac	RHTR	<i>Rhus trilobata</i>	0–30	–
	Subshrub (<.5m)	2SUBS	<i>Subshrub (<.5m)</i>	30	–
	dwarf false indigo	AMNA	<i>Amorpha nana</i>	30	–
Tree					
10	Trees			30–60	
	Tree	2TREE	<i>Tree</i>	0–60	–
	green ash	FRPE	<i>Fraxinus pennsylvanica</i>	0–60	–
	plains cottonwood	PODEM	<i>Populus deltoides ssp. monilifera</i>	0–60	–
	bur oak	QUMA2	<i>Quercus macrocarpa</i>	0–60	–
	American elm	ULAM	<i>Ulmus americana</i>	0–60	–

Table 10. Community 2.1 plant community composition

Group	Common Name	Symbol	Scientific Name	Annual Production (Lb/Acre)	Foliar Cover (%)
Grass/Grasslike					
1	Prairie Sandreed			50–100	
	prairie sandreed	CALO	<i>Calamovilfa longifolia</i>	50–100	–
2	Bluestem			0–10	
	little bluestem	SCSC	<i>Schizachyrium scoparium</i>	0–10	–
3	Needlegrass			150–250	
	needle and thread	HECOC8	<i>Hesperostipa comata ssp. comata</i>	150–250	–
	green needlegrass	NAVI4	<i>Nassella viridula</i>	0–10	–
4	Gramma			50–80	
	blue grama	BOGR2	<i>Bouteloua gracilis</i>	30–80	–
	hairy grama	BOHI2	<i>Bouteloua hirsuta</i>	0–30	–
5	Other Native Grasses			50–100	
	Fendler threeawn	ARPUL	<i>Aristida purpurea var. longiseta</i>	30–40	–
	sand dropseed	SPCR	<i>Sporobolus cryptandrus</i>	30–40	–
	mat sandbur	CELO3	<i>Cenchrus longispinus</i>	10–20	–
	Scribner's rosette grass	DIOLS	<i>Dichanthelium oligosanthes var. scribnerianum</i>	10–20	–
	prairie Junegrass	KOMA	<i>Koeleria macrantha</i>	10–20	–
	western wheatgrass	PASM	<i>Pascopyrum smithii</i>	10–20	–
	Grass, perennial	2GP	<i>Grass, perennial</i>	10–20	–
	saltgrass	DISP	<i>Distichlis spicata</i>	0–10	–
	Canada wildrye	ELCA4	<i>Elymus canadensis</i>	0–10	–
6	Grass-Likes			50–100	
	threadleaf sedge	CAFI	<i>Carex filifolia</i>	50–100	–
	sun sedge	CAINH2	<i>Carex inops ssp. heliophila</i>	20–30	–
	Grass-like (not a true grass)	2GL	<i>Grass-like (not a true grass)</i>	10–20	–

7	Non-Native Grasses			50–100	
	bluegrass	POA	<i>Poa</i>	50–100	–
	crested wheatgrass	AGCR	<i>Agropyron cristatum</i>	0–20	–
	smooth brome	BRIN2	<i>Bromus inermis</i>	0–20	–
	cheatgrass	BRTE	<i>Bromus tectorum</i>	0–20	–
Forb					
8	Forbs			100–150	
	tarragon	ARDR4	<i>Artemisia dracunculus</i>	40–80	–
	hairy false goldenaster	HEVI4	<i>Heterotheca villosa</i>	30–50	–
	sweetclover	MELIL	<i>Melilotus</i>	10–50	–
	wavyleaf thistle	CIUN	<i>Cirsium undulatum</i>	30–50	–
	Cuman ragweed	AMPS	<i>Ambrosia psilostachya</i>	30–40	–
	upright prairie coneflower	RACO3	<i>Ratibida columnifera</i>	30–40	–
	goldenrod	SOLID	<i>Solidago</i>	30–40	–
	scurfpea	PSORA2	<i>Psoralegium</i>	20–30	–
	common dandelion	TAOF	<i>Taraxacum officinale</i>	20–30	–
	white sagebrush	ARLU	<i>Artemisia ludoviciana</i>	20–30	–
	curlycup gumweed	GRSQ	<i>Grindelia squarrosa</i>	10–30	–
	common sunflower	HEAN3	<i>Helianthus annuus</i>	10–20	–
	pussytoes	ANTEN	<i>Antennaria</i>	10–20	–
	Forb (herbaceous, not grass nor grass-like)	2FORB	<i>Forb (herbaceous, not grass nor grass-like)</i>	10–20	–
	Rocky Mountain beeplant	CLSE	<i>Cleome serrulata</i>	10–20	–
	Canadian horseweed	COCA5	<i>Conyza canadensis</i>	10–20	–
	yellow salsify	TRDU	<i>Tragopogon dubius</i>	10–20	–
	common yarrow	ACMI2	<i>Achillea millefolium</i>	10–20	–
	scarlet globemallow	SPCO	<i>Sphaeralcea coccinea</i>	10–20	–
	blacksamson echinacea	ECAN2	<i>Echinacea angustifolia</i>	0–10	–
	Forb, perennial	2FP	<i>Forb, perennial</i>	0–10	–
	spiny phlox	PHHO	<i>Phlox hoodii</i>	10	–
	rush skeletonplant	LYJU	<i>Lygodesmia juncea</i>	10	–
Shrub/Vine					
9	Shrubs			50–100	
	prairie sagewort	ARFR4	<i>Artemisia frigida</i>	30–100	–
	creeping juniper	JUHO2	<i>Juniperus horizontalis</i>	10–20	–
	pricklypear	OPUNT	<i>Opuntia</i>	10–20	–
	rose	ROSA5	<i>Rosa</i>	10–20	–
	silver buffaloberry	SHAR	<i>Shepherdia argentea</i>	10	–
	western snowberry	SYOC	<i>Symphoricarpos occidentalis</i>	0–10	–
	soapweed yucca	YUGL	<i>Yucca glauca</i>	0–10	–
	Subshrub (<.5m)	2SUBS	<i>Subshrub (<.5m)</i>	0–10	–
	chokecherry	PRVI	<i>Prunus virginiana</i>	0–10	–
	skunkbush sumac	RHTR	<i>Rhus trilobata</i>	0–10	–
Tree					

10	Trees			10	
	Tree	2TREE	<i>Tree</i>	10	–
	green ash	FRPE	<i>Fraxinus pennsylvanica</i>	10	–
	plains cottonwood	PODEM	<i>Populus deltoides ssp. monilifera</i>	10	–
	bur oak	QUMA2	<i>Quercus macrocarpa</i>	10	–
	American elm	ULAM	<i>Ulmus americana</i>	10	–

Table 11. Community 3.1 plant community composition

Group	Common Name	Symbol	Scientific Name	Annual Production (Lb/Acre)	Foliar Cover (%)
Grass/Grasslike					
1	Prairie Sandreed			0–52	
	prairie sandreed	CALO	<i>Calamovilfa longifolia</i>	0–52	–
2	Bluestem			0–26	
	big bluestem	ANGE	<i>Andropogon gerardii</i>	0–26	–
	sand bluestem	ANHA	<i>Andropogon hallii</i>	0–26	–
3	Needlegrass			52–78	
	needle and thread	HECOC8	<i>Hesperostipa comata ssp. comata</i>	26–78	–
	porcupinegrass	HESP11	<i>Hesperostipa spartea</i>	0–52	–
	green needlegrass	NAVI4	<i>Nassella viridula</i>	26–52	–
4	Gramma			0–26	
	blue grama	BOGR2	<i>Bouteloua gracilis</i>	0–26	–
	hairy grama	BOHI2	<i>Bouteloua hirsuta</i>	0–26	–
5	Other Native Grasses			52–130	
	prairie Junegrass	KOMA	<i>Koeleria macrantha</i>	26–52	–
	western wheatgrass	PASM	<i>Pascopyrum smithii</i>	26–52	–
	sand dropseed	SPCR	<i>Sporobolus cryptandrus</i>	26	–
	Grass, perennial	2GP	<i>Grass, perennial</i>	0–26	–
	Fendler threeawn	ARPUL	<i>Aristida purpurea var. longiseta</i>	0–26	–
	Canada wildrye	ELCA4	<i>Elymus canadensis</i>	0–26	–
	slender wheatgrass	ELTRS	<i>Elymus trachycaulus ssp. subsecundus</i>	0–26	–
6	Grass-Likes			52–78	
	threadleaf sedge	CAFI	<i>Carex filifolia</i>	52–78	–
	sun sedge	CAINH2	<i>Carex inops ssp. heliophila</i>	0–26	–
	Pennsylvania sedge	CAPE6	<i>Carex pensylvanica</i>	0–26	–
	Grass-like (not a true grass)	2GL	<i>Grass-like (not a true grass)</i>	0–26	–
7	Non-Native Grasses			910–1300	
	bluegrass	POA	<i>Poa</i>	520–1170	–
	smooth brome	BRIN2	<i>Bromus inermis</i>	0–910	–
	crested wheatgrass	AGCR	<i>Agropyron cristatum</i>	0–780	–
	cheatgrass	BRTE	<i>Bromus tectorum</i>	0–260	–
Forb					
8	Forbs			260–390	

	sweetclover	MELIL	<i>Melilotus</i>	0–260	–
	goldenrod	SOLID	<i>Solidago</i>	78–104	–
	tarragon	ARDR4	<i>Artemisia dracunculus</i>	52–78	–
	white sagebrush	ARLU	<i>Artemisia ludoviciana</i>	26–52	–
	wavyleaf thistle	CIUN	<i>Cirsium undulatum</i>	26–52	–
	Forb (herbaceous, not grass nor grass-like)	2FORB	<i>Forb (herbaceous, not grass nor grass-like)</i>	26–52	–
	common yarrow	ACMI2	<i>Achillea millefolium</i>	26–52	–
	Cuman ragweed	AMPS	<i>Ambrosia psilostachya</i>	26–52	–
	common sunflower	HEAN3	<i>Helianthus annuus</i>	26–52	–
	hairy false goldenaster	HEVI4	<i>Heterotheca villosa</i>	26–52	–
	common dandelion	TAOF	<i>Taraxacum officinale</i>	26–52	–
	yellow salsify	TRDU	<i>Tragopogon dubius</i>	26–52	–
	cinquefoil	POTEN	<i>Potentilla</i>	26–52	–
	scurfpea	PSORA2	<i>Psoralegium</i>	26–52	–
	upright prairie coneflower	RACO3	<i>Ratibida columnifera</i>	26–52	–
	beardtongue	PENST	<i>Penstemon</i>	0–26	–
	American vetch	VIAM	<i>Vicia americana</i>	0–26	–
	scarlet globemallow	SPCO	<i>Sphaeralcea coccinea</i>	0–26	–
	blazing star	LIATR	<i>Liatris</i>	0–26	–
	rush skeletonplant	LYJU	<i>Lygodesmia juncea</i>	0–26	–
	stiff sunflower	HEPA19	<i>Helianthus pauciflorus</i>	0–26	–
	Forb, perennial	2FP	<i>Forb, perennial</i>	0–26	–
	Rocky Mountain beeplant	CLSE	<i>Cleome serrulata</i>	0–26	–
	Canadian horseweed	COCA5	<i>Conyza canadensis</i>	0–26	–
	prairie clover	DALEA	<i>Dalea</i>	0–26	–
	blacksamson echinacea	ECAN2	<i>Echinacea angustifolia</i>	0–26	–
	sanddune wallflower	ERCAC	<i>Erysimum capitatum var. capitatum</i>	0–26	–
	curlycup gumweed	GRSQ	<i>Grindelia squarrosa</i>	0–26	–
Shrub/Vine					
9	Shrubs			260–390	
	western snowberry	SYOC	<i>Symphoricarpos occidentalis</i>	130–260	–
	skunkbush sumac	RHTR	<i>Rhus trilobata</i>	26–78	–
	silver buffaloberry	SHAR	<i>Shepherdia argentea</i>	52–78	–
	chokecherry	PRVI	<i>Prunus virginiana</i>	26–52	–
	rose	ROSA5	<i>Rosa</i>	26–52	–
	prairie sagewort	ARFR4	<i>Artemisia frigida</i>	26–52	–
	Subshrub (<.5m)	2SUBS	<i>Subshrub (<.5m)</i>	26–52	–
	leadplant	AMCA6	<i>Amorpha canescens</i>	26–52	–
	dwarf false indigo	AMNA	<i>Amorpha nana</i>	26	–
	creeping juniper	JUHO2	<i>Juniperus horizontalis</i>	0–26	–
	pricklypear	OPUNT	<i>Opuntia</i>	0–26	–
	soapweed yucca	YUGL	<i>Yucca glauca</i>	0–26	–

Tree					
10	Trees			78–130	
	Tree	2TREE	<i>Tree</i>	0–130	–
	green ash	FRPE	<i>Fraxinus pennsylvanica</i>	52–130	–
	plains cottonwood	PODEM	<i>Populus deltoides ssp. monilifera</i>	0–130	–
	bur oak	QUMA2	<i>Quercus macrocarpa</i>	0–130	–
	American elm	ULAM	<i>Ulmus americana</i>	0–130	–

Table 12. Community 4.1 plant community composition

Group	Common Name	Symbol	Scientific Name	Annual Production (Lb/Acre)	Foliar Cover (%)
Grass/Grasslike					
1	Prairie Sandreed			0–7	
	prairie sandreed	CALO	<i>Calamovilfa longifolia</i>	0–7	–
3	Needlegrass			35–70	
	needle and thread	HECOC8	<i>Hesperostipa comata ssp. comata</i>	35–70	–
4	Grama			35–70	
	blue grama	BOGR2	<i>Bouteloua gracilis</i>	35–70	–
	hairy grama	BOHI2	<i>Bouteloua hirsuta</i>	0–7	–
5	Other Native Grasses			70–105	
	Fendler threeawn	ARPUL	<i>Aristida purpurea var. longiseta</i>	35–70	–
	sand dropseed	SPCR	<i>Sporobolus cryptandrus</i>	35–70	–
	mat sandbur	CELO3	<i>Cenchrus longispinus</i>	14–21	–
	Scribner's rosette grass	DIOLS	<i>Dichanthelium oligosanthes var. scribnerianum</i>	14–21	–
	saltgrass	DISP	<i>Distichlis spicata</i>	7–14	–
	prairie Junegrass	KOMA	<i>Koeleria macrantha</i>	7–14	–
	western wheatgrass	PASM	<i>Pascopyrum smithii</i>	7–14	–
	Grass, perennial	2GP	<i>Grass, perennial</i>	0–7	–
6	Grass-Likes			35–70	
	threadleaf sedge	CAFI	<i>Carex filifolia</i>	35–70	–
	Grass-like (not a true grass)	2GL	<i>Grass-like (not a true grass)</i>	0–7	–
7	Non-Native Grasses			105–140	
	bluegrass	POA	<i>Poa</i>	105–140	–
	cheatgrass	BRTE	<i>Bromus tectorum</i>	0–35	–
	crested wheatgrass	AGCR	<i>Agropyron cristatum</i>	0–14	–
	smooth brome	BRIN2	<i>Bromus inermis</i>	0–14	–
Forb					
8	Forbs			105–161	
	sweetclover	MELIL	<i>Melilotus</i>	7–70	–
	Cuman ragweed	AMPS	<i>Ambrosia psilostachya</i>	35–70	–
	tarragon	ARDR4	<i>Artemisia dracunculus</i>	35–70	–
	wavyleaf thistle	CIUN	<i>Cirsium undulatum</i>	28–56	–
	hairy false goldenaster	HEVI4	<i>Heterotheca villosa</i>	28–56	–
	Ceanothus leucodermis	CELE45	<i>Ceanothus leucodermis</i>	28–42	–

	Canadian norseweed	COCA5	<i>Coryza canadensis</i>	28-42	-
	scurfpea	PSORA2	<i>Psoraleidium</i>	28-35	-
	common sunflower	HEAN3	<i>Helianthus annuus</i>	21-28	-
	white sagebrush	ARLU	<i>Artemisia ludoviciana</i>	21-28	-
	pussytoes	ANTEN	<i>Antennaria</i>	14-21	-
	common yarrow	ACMI2	<i>Achillea millefolium</i>	14-21	-
	curlycup gumweed	GRSQ	<i>Grindelia squarrosa</i>	14-21	-
	upright prairie coneflower	RACO3	<i>Ratibida columnifera</i>	14-21	-
	goldenrod	SOLID	<i>Solidago</i>	14-21	-
	scarlet globemallow	SPCO	<i>Sphaeralcea coccinea</i>	14-21	-
	common dandelion	TAOF	<i>Taraxacum officinale</i>	14-21	-
	yellow salsify	TRDU	<i>Tragopogon dubius</i>	14-21	-
	rush skeletonplant	LYJU	<i>Lygodesmia juncea</i>	7-14	-
	Forb, perennial	2FP	<i>Forb, perennial</i>	0-7	-
	blacksamson echinacea	ECAN2	<i>Echinacea angustifolia</i>	0-7	-
	spiny phlox	PHHO	<i>Phlox hoodii</i>	7	-
Shrub/Vine					
9	Shrubs			35-70	
	prairie sagewort	ARFR4	<i>Artemisia frigida</i>	28-56	-
	pricklypear	OPUNT	<i>Opuntia</i>	14-28	-
	soapweed yucca	YUGL	<i>Yucca glauca</i>	0-21	-
	creeping juniper	JUHO2	<i>Juniperus horizontalis</i>	7-14	-
	rose	ROSA5	<i>Rosa</i>	7-14	-
	Subshrub (<.5m)	2SUBS	<i>Subshrub (<.5m)</i>	0-7	-
Tree					
10	Trees			0-7	
	Tree	2TREE	<i>Tree</i>	0-7	-
	green ash	FRPE	<i>Fraxinus pennsylvanica</i>	0-7	-
	plains cottonwood	PODEM	<i>Populus deltoides ssp. monilifera</i>	0-7	-
	bur oak	QUMA2	<i>Quercus macrocarpa</i>	0-7	-
	American elm	ULAM	<i>Ulmus americana</i>	0-7	-

Animal community

Animal Community – Wildlife Interpretations:
Under development.

Animal Community – Grazing Interpretations:

This site is well adapted to managed grazing by domestic livestock. The predominance of herbaceous plants across all plant community phases best lends these sites to grazing by cattle but other domestic grazers with differing diet preferences may also be a consideration depending upon management objectives. Often, the current plant community does not entirely match any particular plant community (as described in the ecological site description). Because of this, a resource inventory is necessary to document plant composition and production. Proper interpretation of this inventory data will permit the establishment of a safe, initial stocking rate for the type and class of animals and level of grazing management. More accurate stocking rate estimates should eventually be calculated using actual stocking rate information and monitoring data.

Hydrological functions

Water is the principal factor limiting herbage production on this site. The site is dominated by soils in hydrologic groups A and B, with localized areas in hydrologic group D. Infiltration varies from rapid to moderately rapid and runoff potential varies from negligible to very low depending on soil hydrologic group and ground cover. In many cases, areas with greater than 75% ground cover have the greatest potential for high infiltration and lower runoff. An exception would be where short grasses form a dense sod and dominate the site. Areas where ground cover is less than 50% have the greatest potential to have reduced infiltration and higher runoff (refer to Section 4, NRCS National Engineering Handbook for runoff quantities and hydrologic curves).

Recreational uses

This site provides hunting opportunities for upland game species. The wide variety of plants which bloom from spring until fall have an esthetic value that appeals to visitors.

Wood products

No appreciable wood products are present on the site.

Other products

Seed harvest of native plant species can provide additional income on this site.

Inventory data references

Information presented here has been derived from NRCS clipping and other inventory data. Also, field knowledge of range-trained personnel was used. All descriptions were peer reviewed and/or field tested by various private, state and federal agency specialist.

Those involved in developing this site description include: Dennis Froemke, NRCS Range Management Specialist; Jeff Printz, NRCS State Range Management Specialist; Stan Boltz, NRCS Range Management Specialist; Darrell Vanderbusch, NRCS Resource Soil Scientist; L. Michael Stirling, NRCS Range Management Specialist; David Dewald, NRCS State Biologist; and Brad Podoll, NRCS Biologist.

Those involved in developing this site description include: Dennis Froemke, NRCS Range Management Specialist; Stan Boltz, NRCS Range Management Specialist and Darrell VanderBusch, NRCS Resource Soil Scientist.

Data Source Number of Records Sample Period State County

SCS-RANGE-417 0

Ocular estimates 3 1998 -2001 ND; SD Dunn, Morton, Stark

Other references

High Plains Regional Climate Center, University of Nebraska, 830728 Chase Hall, Lincoln, NE 68583-0728. (<http://hpccsun.unl.edu>)

USDA, NRCS. National Water and Climate Center, 101 SW Main, Suite 1600, Portland, OR 97204-3224. (<http://wcc.nrcs.usda.gov>)

USDA, NRCS. National Range and Pasture Handbook, September 1997

USDA, NRCS. National Soil Information System, Information Technology Center, 2150 Centre Avenue, Building A, Fort Collins, CO 80526. (<http://nasis.nrcs.usda.gov>)

USDA, NRCS. 2001. The PLANTS Database, Version 3.1 (<http://plants.usda.gov>). National Plant Data Center, Baton Rouge, LA 70874-4490 USA.

USDA, NRCS, Various Published Soil Surveys.

Contributors

Jeff Printz

Jeff Printz/Stan Boltz

Rangeland health reference sheet

Interpreting Indicators of Rangeland Health is a qualitative assessment protocol used to determine ecosystem condition based on benchmark characteristics described in the Reference Sheet. A suite of 17 (or more) indicators are typically considered in an assessment. The ecological site(s) representative of an assessment location must be known prior to applying the protocol and must be verified based on soils and climate. Current plant community cannot be used to identify the ecological site.

Author(s)/participant(s)	D. Froemke, J. Forman, J. Printz
Contact for lead author	jeff.printz@nd.usda.gov 701-530-2080
Date	05/13/2011
Approved by	Jeff Printz
Approval date	
Composition (Indicators 10 and 12) based on	Annual Production

Indicators

1. **Number and extent of rills:** Rills should not be present.

2. **Presence of water flow patterns:** Barely observable.

3. **Number and height of erosional pedestals or terracettes:** Essentially non-existent.

4. **Bare ground from Ecological Site Description or other studies (rock, litter, lichen, moss, plant canopy are not bare ground):** Bare ground is less than 15%.

5. **Number of gullies and erosion associated with gullies:** Active gullies should not be present. Existing gullies should be "healed" with a good vegetative cover.

6. **Extent of wind scoured, blowouts and/or depositional areas:** None.

7. **Amount of litter movement (describe size and distance expected to travel):** Little to no litter movement. Plant litter remains in place and is not moved by erosional forces.

8. **Soil surface (top few mm) resistance to erosion (stability values are averages - most sites will show a range of values):** Plant cover and litter is at 85% or greater of soil surface and maintains soil surface integrity. Stability class anticipated to be 5 or greater.

9. **Soil surface structure and SOM content (include type of structure and A-horizon color and thickness):** Use soil

series description for depth, color and structure of A-horizon.

10. **Effect of community phase composition (relative proportion of different functional groups) and spatial distribution on infiltration and runoff:** High grass canopy and basal cover and small gaps between plants should reduce raindrop impact and slow overland flow, providing increased time for infiltration to occur. Healthy, deep rooted native grasses enhance infiltration and reduce runoff.
-

11. **Presence and thickness of compaction layer (usually none; describe soil profile features which may be mistaken for compaction on this site):** No compaction layer or soil surface crusting should be evident.
-

12. **Functional/Structural Groups (list in order of descending dominance by above-ground annual-production or live foliar cover using symbols: >>, >, = to indicate much greater than, greater than, and equal to):**

Dominant: Tall, warm-season rhizomatous grasses >

Sub-dominant: mid-stature, cool-season bunchgrasses > forbs >

Other: shrubs > grass-likes > mid, cool-season rhizomatous grasses > short, warm-season grasses > trees

Additional: Due to differing root structure and distribution, Kentucky bluegrass and smooth brome grass do not fit into reference plant community F/S groups.

13. **Amount of plant mortality and decadence (include which functional groups are expected to show mortality or decadence):** Very low.
-

14. **Average percent litter cover (%) and depth (in):** Litter cover is in contact with soil surface.
-

15. **Expected annual annual-production (this is TOTAL above-ground annual-production, not just forage annual-production):** Representative value = 3000 lbs/ac with a range from 2100 lbs/ac to 3900 lbs/ac (air dry weight) depending upon growing conditions.
-

16. **Potential invasive (including noxious) species (native and non-native). List species which BOTH characterize degraded states and have the potential to become a dominant or co-dominant species on the ecological site if their future establishment and growth is not actively controlled by management interventions. Species that become dominant for only one to several years (e.g., short-term response to drought or wildfire) are not invasive plants. Note that unlike other indicators, we are describing what is NOT expected in the reference state for the ecological site:** State and local noxious weeds, smooth brome grass, Kentucky bluegrass, Rocky Mountain Juniper.
-

17. **Perennial plant reproductive capability:** All species are capable of reproducing.
-

