

## Ecological site R058BY262WY Shallow Loamy (SwLy) 15-17" PZ

Last updated: 10/04/2023  
Accessed: 04/30/2024

### General information

**Provisional.** A provisional ecological site description has undergone quality control and quality assurance review. It contains a working state and transition model and enough information to identify the ecological site.

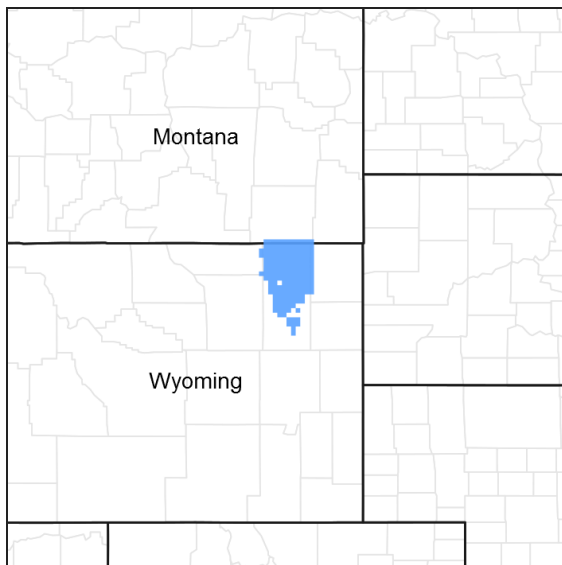

Figure 1. Mapped extent

Areas shown in blue indicate the maximum mapped extent of this ecological site. Other ecological sites likely occur within the highlighted areas. It is also possible for this ecological site to occur outside of highlighted areas if detailed soil survey has not been completed or recently updated.

### MLRA notes

Major Land Resource Area (MLRA): 058B–Northern Rolling High Plains, Southern Part

MLRA 58B is located in northeastern Wyoming (95 percent) and extreme southeastern Montana (5 percent). It is comprised of sedimentary plains, scoria hills, and river valleys. The major rivers include the Powder, Tongue, Belle Fourche, Cheyenne, and North Platte. Tributaries include the Little Powder River, Little Missouri River, Clear Creek, Crazy Woman Creek, and others. This MLRA is traversed by Interstates 25 and 90, and U.S. Highways 14 and 16. The extent of MLRA 58B covers approximately 12.3 million acres. Major land uses include rangeland (approximately 93 percent), cropland, pasture, and hayland (approximately 2 percent), and forest, urban, and miscellaneous uses (approximately 5 percent). Cities include Buffalo, Casper, Sheridan, and Gillette, WY. Land ownership is mostly private. Federal lands include the Thunder Basin National Grassland (U.S. Forest Service) and lands administered by the Bureau of Land Management. Areas of interest in MLRA 58B in Wyoming include Fort Phil Kearny State Historic Site, Glendo State Park, and Lake DeSmet. The elevations in MLRA 58B increase gradually from north to south and range from approximately 2,900 to 5,900 feet. A few buttes are higher than 6,800 feet. The average annual precipitation in this area ranges from 10 to 17 inches per year. Precipitation occurs mostly during the growing season, often during rapidly developing thunderstorms. Mean annual air temperature is 46 degrees Fahrenheit. Summer temperatures may exceed 100 degrees Fahrenheit. Winter temperatures may drop to below zero. Snowfall averages 45 inches per year, but varies from 25 to over 70 inches in some locales.

## Classification relationships

USDA Natural Resources Conservation Service (NRCS):  
Land Resource Region—G Western Great Plains Range and Irrigation; Major Land Resource Area (MLRA)—58B  
Northern Rolling High Plains, Southern Part (USDA, 2006)

Relationship to Other Classifications:

USDA Forest Service (FS) Classification Hierarchy:

Province—331 Great Plains-Palouse Dry Steppe; Section—331G-Powder River Basin; Subsections—331Gb  
Montana Shale Plains, 331Ge Powder River Basin, 331Gf South Powder River Basin-Scoria Hills (Cleland et al,  
1997)

Environmental Protection Agency (EPA) Classification Hierarchy:

Level III Ecoregion—43 Northwestern Great Plains; Level IV Ecoregion—43p Scoria Hills, 43q Mesic-Dissected  
Plains, 43w Powder River Basin (EPA, 2013)  
<https://www.epa.gov/eco-research/ecoregions>

## Ecological site concept

The Shallow Loamy 15 to 17 inch Precipitation Zone ecological site occurs on nearly level to steeply sloping hills and ridges, on sedimentary plains or uplands. Primary production is from cool-season midgrasses (bunch and rhizomatous), warm-season midgrasses (bunch), and secondary warm-season shortgrasses. There is also lesser component of forbs and shrubs. The soils a sandy loam to clay loam with a restrictive layer between 10 to 20 inches deep.

## Associated sites

R058BY258WY	<b>Shallow Clayey (SwCy) 15-17" PZ</b> Shallow Clayey sites are similar but occur on shale parent material more where Shallow Loamy occurs on interbedded parent materials.
R058BY222WY	<b>Loamy (Ly) 15-17" PZ</b> Loamy is lower on the landform with deeper soils and higher production.

## Similar sites

R058BY162WY	<b>Shallow Loamy (SwLy) 10-14" PZ</b> Shallow Loamy 10-14" P.Z. has lower production.
-------------	--

Table 1. Dominant plant species

Tree	Not specified
Shrub	Not specified
Herbaceous	(1) <i>Pascopyrum smithii</i> (2) <i>Pseudoroegneria spicata</i>

## Physiographic features

This site occurs on nearly level to steeply sloping hills and ridges, on sedimentary plains or uplands.

Table 2. Representative physiographic features

Landforms	(1) Hill (2) Ridge
-----------	-----------------------

Runoff class	Low to high
Flooding frequency	None
Ponding frequency	None
Elevation	1,006–1,585 m
Slope	0–60%
Water table depth	203 cm
Aspect	Aspect is not a significant factor

## Climatic features

The average annual precipitation ranges from 10 to 17 inches per year across MLRA 58B. There are two Precipitation Zones (PZs). The 10 to 14 inch precipitation zone is predominant across the MLRA, including portions of Sheridan, Johnson, and Natrona Counties; portions of Campbell and Converse Counties; and smaller portions of Weston and Niobrara Counties. The 15 to 17 inch precipitation zone occurs in northern and eastern portions of the MLRA, including portions of Sheridan, Campbell, and western Crook Counties. Wide fluctuations in precipitation may occur from year to year, and occasional periods of extended drought (longer than one year in duration) can be expected. Two-thirds of the annual precipitation occurs during the growing season from May through September. Mean Annual Air Temperature (MAAT) is 46 degrees Fahrenheit. Cold air outbreaks from Canada in winter move rapidly from northwest to southeast and account for extreme minimum temperatures. Chinook winds may also occur in winter and bring rapid rises in temperature. Extreme storms may occur during the winter, but most severely affect ranching operations during late winter and spring. High-intensity afternoon thunderstorms may occur during the summer. Annual wind speeds average about 5 mph. Daytime winds are generally stronger than nighttime winds. Occasional strong storms may bring brief periods of high winds with gusts of more than 75 mph. The average length of the freeze-free period (28 degrees Fahrenheit) is 125 days and generally occurs from May 16 to September 19. The average frost-free period (32 degrees Fahrenheit) is 101 days and generally occurs from June 1 to September 9.

The growth of native cool-season plants begins in late April to early May with peak growth occurring in mid to late June. Native warm-season plants begin growth in late May to early June and continue into August. Regrowth of cool-season plants occurs in September in most years, depending upon moisture.

Note: The climate described here is based on historic climate station data and is averaged to provide an overview of the annual precipitation, temperatures, and growing season. Future climate is beyond the scope of this document. However, research to determine the effects of elevated CO<sub>2</sub> and heating on mixed-grass prairie ecosystems, and how it may relate to future plant communities, is ongoing.

For detailed information, or to find a specific climate station, visit the Western Regional Climate Center (WRCC) website: Western Regional Climate Center, Historical Data, Western U.S. Climate summaries, NOAA Coop Stations, Wyoming (Note: Montana climate stations are also listed under the Wyoming link).  
<https://wrcc.dri.edu/summary/Climismwy.html>

Wind speed averages can be found at the WRCC home page, under the Specialty Climate tab: <https://wrcc.dri.edu/>

The following tables represent area-wide climate data for the 15 to 17 inch precipitation zone:

**Table 3. Representative climatic features**

Frost-free period (characteristic range)	88-105 days
Freeze-free period (characteristic range)	122-130 days
Precipitation total (characteristic range)	381-406 mm
Frost-free period (actual range)	83-109 days
Freeze-free period (actual range)	119-130 days
Precipitation total (actual range)	381-432 mm

Frost-free period (average)	101 days
Freeze-free period (average)	125 days
Precipitation total (average)	381 mm

### Climate stations used

- (1) DOUGLAS 1 SE [USC00482685], Douglas, WY
- (2) BIDDLE 8 SW [USC00240743], Biddle, MT
- (3) DILLINGER [USC00482580], Gillette, WY
- (4) GILLETTE 4SE [USC00483855], Gillette, WY
- (5) LEITER 9N [USC00485506], Clearmont, WY
- (6) SHERIDAN CO AP [USW00024029], Sheridan, WY

### Influencing water features

This upland ecological site is not influenced by a water table or run in from adjacent sites. Due to the semi-arid climate in which it occurs, the water budget is normally contained within the soil pedon. Soil moisture is recharged by spring rains, but it rarely exceeds field capacity in the upper 40 inches before being depleted by evapotranspiration. During intense precipitation events, precipitation rates frequently exceed infiltration rates and the site delivers moisture to downslope sites through surface runoff. Moisture loss through evapotranspiration exceeds precipitation for a majority of the growing season. Soil moisture is the primary limiting factor for vegetative production on this ecological site.

### Wetland description

N/A

### Soil features

The soils on this site are well drained, shallow to bedrock and formed in residuum and slope alluvium weathered from sedimentary rock. They typically have a moderate to moderately rapid permeability class. The available water capacity is typically very low to low. The surface layer of the soils in this site are typically clay loam or loam but may include silt loam or very fine sandy loam. The surface layer ranges from a depth of 1 to 6 inches thick. The subsoil is typically clay loam or loam. Soils in this site typically have carbonates at the surface; but some soils may be leached as deep as 2 to 6 inches. Soils formed in material derived from porcelanite (scoria) are inconsistently calcareous. These soils are susceptible to erosion by water and wind. The potential for water erosion accelerates with increasing slope. The soil moisture regime is typically aridic ustic. The soil temperature regime is mesic or frigid.

Major soil series correlated to this ecological site include: Fairburn and Ironbutte.

The attributes listed below represent 0-40 inches in depth or to the first restrictive layer.

**Table 4. Representative soil features**

Parent material	(1) Residuum–sedimentary rock (2) Slope alluvium–sedimentary rock (3) Colluvium
Surface texture	(1) Clay loam (2) Loam (3) Silt loam (4) Very fine sandy loam
Drainage class	Well drained
Permeability class	Moderate to moderately rapid
Soil depth	25–51 cm

Surface fragment cover <=3"	0–10%
Surface fragment cover >3"	0–20%
Available water capacity (Depth not specified)	4.06–14.22 cm
Calcium carbonate equivalent (Depth not specified)	0–10%
Electrical conductivity (Depth not specified)	0–4 mmhos/cm
Sodium adsorption ratio (Depth not specified)	0–5
Soil reaction (1:1 water) (Depth not specified)	6.6–8.4
Subsurface fragment volume <=3" (Depth not specified)	0–40%
Subsurface fragment volume >3" (Depth not specified)	0–30%

## Ecological dynamics

The Reference Plant Community is not necessarily the management goal, as other vegetative states may be considered desired plant communities as long as critical resource concerns are met. The Reference State is characterized by cool-season rhizomatous midgrasses (western wheatgrass, thickspike wheatgrass), cool-season bunch midgrasses (bluebunch wheatgrass, needle and thread) warm-season bunch midgrass (little bluestem), and warm-season shortgrass (blue grama). Other grasses and grass-likes include prairie Junegrass, Cusick's bluegrass, Sandberg bluegrass, and threadleaf sedge, also hairy- and sideoats grama, Fendler threeawn, plains muhly, and threadleaf sedge. Forbs (dotted blazing star, scarlet globemallow, buckwheat species, and phlox), and shrubs (skunkbush sumac and Wyoming big sagebrush) are also present. Trees such as Rocky Mountain juniper occasionally occur in minor amounts. The Reference Plant Community is not necessarily the management goal, as other vegetative states may be considered desired plant communities as long as critical resource concerns are met.

In addition to the Reference State, other plant communities can occur on this site and are usually the result of historic management practices. Grazing practices such as continuous season-long or year-long grazing, heavier stocking rates, or a combination of these factors on this ecological site results in bunchgrasses such as needle and thread decreasing in both frequency and production. Grasses and grass-likes such as blue grama, threadleaf sedge, and sixweeks fescue will increase. Forbs and shrubs such as hairy false goldenaster, tansyaster, broom snakeweed, and prairie sagewort (also known as fringed sagewort), will also increase. If continued, the plant community will become sod-bound, and all midgrasses can eventually be removed from the plant community. Over the long-term, this excessive use in combination with high stock densities, will result in bare ground developing and shrubs such as pricklypear, broom snakeweed; and annual forbs such as woolly plantain, field cottonrose, and pepperweed increasing or invading. Other invasives include field brome (also known as Japanese brome) and cheatgrass. There are various transitional stages which may occur on this ecological site. The information presented is representative of a dynamic set of plant communities that illustrate the complex interaction of several ecological processes.

## State and transition model

## Shallow Loamy 15-17" PZ

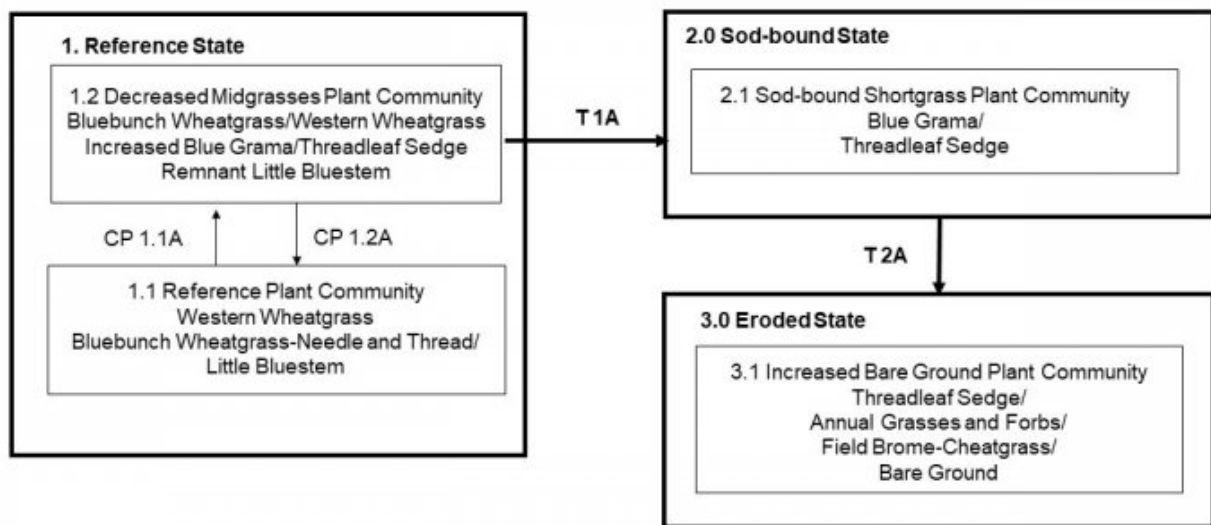

CP- Community Pathway

T- Transition

CP1.1A- Continuous seasonal-use grazing, continuous grazing without adequate recovery, drought

CP 1.2A- Prescribed grazing with adequate recovery and proper stocking, normal precipitation

T1A- Continuous grazing without adequate recovery, fire

T2A- Long-term continuous grazing without adequate recovery, heavy continuous grazing with overstocking

## State 1 Reference State

The Reference State is characterized by two distinct plant community phases: Reference and Decreased Midgrasses Plant Community. The plant communities, and various successional stages between them, represent the natural range of variability within the Reference State.

### Community 1.1 *Artemisia tridentata wyomingensis*/*Pseudoroegneria spicata*-*Pascopyrum smithii* (Wyoming big sagebrush/bluebunch wheatgrass-western wheatgrass)

This is the interpretive plant community for this site. It is well adapted to the Northern Great Plains climate. This community developed with grazing by large herbivores and is suited to grazing by domestic livestock. Historically, fires likely were patchy and randomly distributed. This plant community can be found on areas where grazed plants receive adequate periods of recovery during the growing season. The potential vegetation is about 75 percent grasses and grass-likes, 15 percent forbs, and 10 percent woody plants. The plant community is predominately cool-season midgrasses, with a smaller component of warm-season mid- and shortgrasses. The major grasses and grass-likes include western- and thickspike wheatgrass, bluebunch wheatgrass, and needle and thread. Secondary and minor grasses and grass-likes include little bluestem, prairie Junegrass, threadleaf sedge, Cusick's bluegrass, green needlegrass, sideoats grama, and blue- and hairy grama, Fendler's threeawn, and plains muhly. A variety of forbs include American vetch, white- and purple prairieclover, breadroot scurfpea, and prairie coneflower. Other forbs include dotted blazing star (also known as dotted gayfeather), scarlet globemallow, sulphur-flower buckwheat, and spiny phlox. Primary subshrubs and shrubs are prairie sagewort (also known as fringed sagebrush), winterfat, big sagebrush, rubber rabbitbrush, and skunkbush sumac. (see the Species Composition List for additional information.) Plant diversity is high. In the Shallow Loamy 15 to 17 inch Precipitation Zone (PZ) ecological site, the

total annual production (air-dry weight) is about 1,300 pounds per acre during an average year, but it can range from about 1,000 pounds per acre in unfavorable years to about 1,600 pounds per acre in above-average years. Defoliation levels should be determined as part of a grazing management plan based on objectives. Nutrient and water cycles, and energy flow are functioning properly. Infiltration rates are moderate, and soil erosion is low. Litter is properly distributed where vegetative cover is continuous. Plant decadence and natural mortality are low. This community is resistant to many disturbances except excessive grazing, or development into urban or other uses.

**Table 5. Annual production by plant type**

Plant Type	Low (Kg/Hectare)	Representative Value (Kg/Hectare)	High (Kg/Hectare)
Grass/Grasslike	1401	1821	2242
Shrub/Vine	196	258	319
Forb	112	146	179
<b>Total</b>	<b>1709</b>	<b>2225</b>	<b>2740</b>

**Figure 9. Plant community growth curve (percent production by month). WY1401, 10-14NP upland sites.**

Jan	Feb	Mar	Apr	May	Jun	Jul	Aug	Sep	Oct	Nov	Dec
0	0	0	10	30	35	10	5	5	5	0	0

## Community 1.2

### **Artemisia tridentata wyomingensis/Pseudoroegneria spicata-Bouteloua gracilis (Wyoming big sagebrush/bluebunch wheatgrass-blue grama)**

This plant community developed with excessive grazing without adequate recovery during the growing season. Grazing-tolerant species such as blue grama and threadleaf sedge have noticeably increased. Midgrasses such as needle and thread may initially increase or decrease depending on the season of grazing use. Palatable forbs such as white and purple prairieclover, American vetch, and penstemon are present in reduced amounts. Hairy false goldenaster, slimflower scurfpea, scarlet globemallow, prairie sagewort (fringed sagewort), and broom snakeweed have increased. Natural disturbances such as drought and/or fire can contribute to this shift. In the Shallow Loamy 15 to 17 inch Precipitation Zone ecological site, the total annual production (air-dry weight) is about 1,000 pounds per acre during an average year, but it can range from about 800 pounds per acre in unfavorable years to about 1,200 pounds per acre in above-average years. Total aboveground biomass has been reduced. Reduction of rhizomatous wheatgrasses, nitrogen-fixing forbs, and increased warm-season shortgrasses have begun to alter the biotic integrity of this community. Water and nutrient cycles may be impaired. Nearly all plant species typically found in the Reference Plant Community are present and will respond to changes in grazing management.

**Figure 10. Plant community growth curve (percent production by month). WY1401, 10-14NP upland sites.**

Jan	Feb	Mar	Apr	May	Jun	Jul	Aug	Sep	Oct	Nov	Dec
0	0	0	10	30	35	10	5	5	5	0	0

## Pathway 1.1A

### **Community 1.1 to 1.2**

Excessive grazing without adequate recovery between grazing events, drought, or fire can shift this plant community toward the Decreased Midgrasses Plant Community. Over a period of years, plant species less tolerant to frequent and severe defoliation will begin to decrease, and those more tolerant will begin to increase. Excessive grazing from year-to-year will result in a reduction or loss of cool-season species. Biotic integrity and water and nutrient cycles may become impaired because of this community pathway.

## Pathway 1.2A

### **Community 1.2 to 1.1**

Grazing that allows for adequate recovery between grazing events, and proper stocking rates, will shift the Decreased Midgrasses Plant Community back toward the Reference Plant Community. Natural disturbances such as return to normal precipitation will contribute to this shift.

## State 2 Sod-Bound State

This state is characterized by the Sod-bound Plant Community. An ecological threshold has been crossed and a significant amount of production and diversity has been lost when compared to the Reference State. Significant biotic and soil changes have negatively impacted energy flow and the nutrient and hydrologic cycles. This is a very stable state, resistant to change due to the high tolerance of blue grama and/or buffalograss to grazing, the development of a shallow root system (root pan), and subsequent changes in hydrology and nutrient cycling. The loss of other functional/structural groups such as cool-season bunch and rhizomatous grasses, forbs, and shrubs, reduces the biodiversity and productivity of this site.

### Community 2.1 **Artemisia tridentata wyomingensis-Opuntia polyacantha/Bouteloua gracilis-Carex filifolia (Wyoming big sagebrush-plains pricklypear/blue grama-threadleaf sedge)**

This plant community develops under long-term frequent and severe defoliation. This typically occurs when the community has been excessively grazed with heavy stocking rates, throughout the growing season over a period of many years. The midgrasses and palatable forbs have been eliminated. The dominant species are blue grama and threadleaf sedge. These species have developed into a sod-bound condition occurring in localized colonies exhibiting a mosaic appearance. Perennial threeawn species such as Fendler's threeawn have increased. Forbs such as scarlet globemallow, wild onion, death camas, and slimflower scurfpea remain. Forbs and shrubs that continue to increase are Cuman ragweed (western ragweed), hairy false goldenaster, prairie sagewort (fringed sagewort), and pricklypear. Plant diversity is low. Energy flow, water cycle and mineral cycle have been negatively affected. Litter levels are very low and unevenly distributed. The total annual production (air-dry weight) is about 800 pounds per acre during an average year, but it can range from about 600 pounds per acre in unfavorable years to about 1,000 pounds per acre in above-average years. This plant community is extremely resistant to change. Many plant species are missing a seed source is not readily available.

Figure 11. Plant community growth curve (percent production by month). WY5803, Northern Rolling High Plains, Southern Part, cool-season/warm-season co-dominant. Cool-season/warm-season co-dominant.

Jan	Feb	Mar	Apr	May	Jun	Jul	Aug	Sep	Oct	Nov	Dec
		3	10	20	28	21	10	5	3		

## State 3 Eroded State

The Eroded State develops with long-term excessive grazing or frequent and severe defoliation, without adequate recovery between grazing events, heavy, excessive grazing with overstocking. An ecological threshold has been crossed. Soil erosion and loss of organic matter or carbon reserves are resource concerns.

### Community 3.1 **Artemisia tridentata wyomingensis-Opuntia polyacantha/Aristida purpurea-Bromus tectorum (Wyoming big sagebrush-plains pricklypear/Fendler's threeawn-cheatgrass)**

This plant community occurs where the rangeland is grazed year-round, at high stock densities. Physical impact such as trampling, soil compaction, and trailing typically contribute to this transition. The plant composition is made of annuals with a few species of perennial forbs and grasses that are very tolerant to frequent and severe defoliation. Grasses include Fendler's threeawn. Annuals such as sixweeks fescue, Russian thistle, and kochia have increased or invaded. The dominant forbs include hairy false goldenaster, curlycup gumweed, field cottonrose, and woolly plantain. Green sagewort, broom snakeweed, and pricklypear are increasing. Annual bromes such as field brome (also known as Japanese brome), and cheatgrass invade. The total annual production (air-dry weight) is



about 600 pounds per acre during an average year, but it can range from about 350 pounds per acre in unfavorable years to about 750 pounds per acre in above-average years. Annual production is highly variable and should be determined on-site. Soil erosion hazard has increased due to the increase of bare ground. Runoff typically is high and infiltration is low. All ecological functions are impaired. Desertification is advanced.

Figure 12. Plant community growth curve (percent production by month). WY5803, Northern Rolling High Plains, Southern Part, cool-season/warm-season co-dominant. Cool-season/warm-season co-dominant.

Jan	Feb	Mar	Apr	May	Jun	Jul	Aug	Sep	Oct	Nov	Dec
		3	10	20	28	21	10	5	3		

### Transition T1A State 1 to 2

Excessive grazing without adequate recovery between grazing events or frequent and severe defoliation, will shift this plant community across an ecological threshold toward the Sod-Bound State. Biotic integrity and hydrologic function will be impaired because of this transition.

### Transition T2A State 2 to 3

Long-term excessive grazing or frequent and severe defoliation without adequate recovery between grazing events, or heavy, excessive grazing with overstocking, will cause a shift across an ecological threshold to the Eroded State. Non-native annual bromes begin to invade in this transition.

## Additional community tables

Table 6. Community 1.1 plant community composition

Group	Common Name	Symbol	Scientific Name	Annual Production (Kg/Hectare)	Foliar Cover (%)
<b>Grass/Grasslike</b>					
1	<b>Cool-Season Rhizomatous</b>			280–448	
	western wheatgrass	PASM	<i>Pascopyrum smithii</i>	280–448	5–25
	thickspike wheatgrass	ELLA3	<i>Elymus lanceolatus</i>	280–448	5–25
2	<b>Cool-Season Midgrasses/Grass-likes</b>			616–986	
	bluebunch wheatgrass	PSSP6	<i>Pseudoroegneria spicata</i>	280–448	10–25
	needle and thread	HECO26	<i>Hesperostipa comata</i>	112–179	1–10
	threadleaf sedge	CAFI	<i>Carex filifolia</i>	112–179	1–10
	green needlegrass	NAVI4	<i>Nassella viridula</i>	112–179	1–10
3	<b>Warm-Season Bunch Midgrass</b>			224–359	
	sideoats grama	BOCU	<i>Bouteloua curtipendula</i>	112–179	1–10
	little bluestem	SCSC	<i>Schizachyrium scoparium</i>	112–179	1–10
4	<b>Warm-Season Shortgrass</b>			112–179	
	blue grama	BOGR2	<i>Bouteloua gracilis</i>	112–179	1–10
5	<b>Miscellaneous</b>			168–269	
	Grass, perennial	2GP	<i>Grass, perennial</i>	56–90	1–5
	purple threeawn	ARPU9	<i>Aristida purpurea</i>	56–90	1–5
	hairy grama	BOHI2	<i>Bouteloua hirsuta</i>	56–90	1–5
	prairie Junegrass	KOMA	<i>Koeleria macrantha</i>	56–90	1–5
	Sandberg bluegrass	POSE	<i>Poa secunda</i>	56–90	1–5
	plains reedgrass	CAMO	<i>Calamagrostis montanensis</i>	56–90	1–5

	plains ricegrass	ACHY	<i>Achnatherum hymenoides</i>	56-90	1-5
	plains muhly	MUCU3	<i>Muhlenbergia cuspidata</i>	56-90	1-5
	needleleaf sedge	CADU6	<i>Carex duriuscula</i>	56-90	1-5
<b>Forb</b>					
6	<b>Forbs</b>			112-179	
	stemless mock goldenweed	STAC	<i>Stenotus acaulis</i>	56-90	1-5
	aster	ASTER	<i>Aster</i>	56-90	1-5
	desertparsley	LOMAT	<i>Lomatium</i>	56-90	1-5
	large Indian breadroot	PEES	<i>Pediomelum esculentum</i>	56-90	1-5
	scarlet beeblossom	GACO5	<i>Gaura coccinea</i>	56-90	1-5
	common yarrow	ACMI2	<i>Achillea millefolium</i>	56-90	1-5
	rosy pussytoes	ANRO2	<i>Antennaria rosea</i>	56-90	1-5
	milkvetch	ASTRA	<i>Astragalus</i>	56-90	1-5
	sulphur-flower buckwheat	ERUM	<i>Eriogonum umbellatum</i>	56-90	1-5
	purple prairie clover	DAPU5	<i>Dalea purpurea</i>	56-90	1-5
	white prairie clover	DACA7	<i>Dalea candida</i>	56-90	1-5
	bluebells	MERTE	<i>Mertensia</i>	56-90	1-5
	textile onion	ALTE	<i>Allium textile</i>	56-90	1-5
	Forb, perennial	2FP	<i>Forb, perennial</i>	56-90	1-5
	spiny phlox	PHHO	<i>Phlox hoodii</i>	56-90	1-5
	prairie thermopsis	THRH	<i>Thermopsis rhombifolia</i>	56-90	1-5
	tapertip hawksbeard	CRAC2	<i>Crepis acuminata</i>	56-90	1-5
	American vetch	VIAM	<i>Vicia americana</i>	56-90	1-5
<b>Shrub/Vine</b>					
7	<b>Shrubs</b>			168-269	
	Wyoming big sagebrush	ARTRW8	<i>Artemisia tridentata ssp. wyomingensis</i>	56-90	1-5
	prairie sagewort	ARFR4	<i>Artemisia frigida</i>	56-90	1-5
	rubber rabbitbrush	ERNA10	<i>Ericameria nauseosa</i>	56-90	1-5
	winterfat	KRLA2	<i>Krascheninnikovia lanata</i>	56-90	1-5
	Shrub (>.5m)	2SHRUB	<i>Shrub (&gt;.5m)</i>	56-90	1-5
	Subshrub (<.5m)	2SUBS	<i>Subshrub (&lt;.5m)</i>	56-90	1-5
<b>Tree</b>					
8	<b>Trees</b>			28-50	
	ponderosa pine	PIPO	<i>Pinus ponderosa</i>	28-50	1-5
	Rocky Mountain juniper	JUSC2	<i>Juniperus scopulorum</i>	28-50	1-5

## Animal community

Animal Community – Wildlife Interpretations (from 2001 ESD; will be revised in future updates)

Rhizomatous wheatgrass/ needleandthread/Blue grama (Reference): The predominance of grasses in this plant community favors grazers and mixed-feeders, such as bison, elk, and antelope. Suitable thermal and escape cover for deer may be limited due to the low quantities of woody plants. However, topographical variations could provide

some escape cover. When found adjacent to sagebrush dominated states, this plant community may provide brood rearing/foraging areas for sage grouse, as well as lek sites. Other birds that would frequent this plant community include western meadowlarks, horned larks, and golden eagles. Many grassland-obligate small mammals would occur here.

Heavy Sagebrush: This plant community can provide important winter foraging for elk, mule deer and antelope, as sagebrush can approach 15 percent protein and 40 to 60 percent digestibility during that time. This community can provide nesting and brood rearing habitat for sage grouse.

Mixed Sagebrush/Grass: The combination of an overstory of sagebrush and an understory of grasses and forbs provide a very diverse plant community for wildlife. The crowns of sagebrush tends to break up hard crusted snow on winter ranges, so mule deer and antelope may use this state for foraging and cover year-round, as would cottontail and jack rabbits. It provides important winter, nesting, brood-rearing, and foraging habitat for sage grouse. Brewer's sparrows' nest in big sagebrush plants, and hosts of other nesting birds utilize stands in the 20 to 30 percent cover range.

Blue Grama Sod: These communities provide limited foraging for antelope and other grazers. They may be used as a foraging site by sage grouse if proximal to woody cover and if the Historic Climax Plant Community or the Mixed Sagebrush/Grass Plant Community is limiting. Generally, these are not target plant communities for wildlife habitat management.

Animal Community – Grazing Interpretations (updated in 2019 Provisional revision)

The following table is a guide to stocking rates for the plant communities described in the Shallow Loamy 15 to 17 inch Precipitation Zone ecological site. These are conservative estimates for initial planning. On-site conditions will vary, and stocking rates should be adjusted based on range inventories, animal kind and class, forage availability (adjusted for slope and distance to water), and the type of grazing system (number of pastures, planned moves, etc.), all of which is determined in the conservation planning process.

The following stocking rates are based on the total annual forage production in a normal year multiplied by 25 percent harvest efficiency of preferred and desirable forage species, divided by 912 pounds of ingested air-dry vegetation for an animal unit per month (Natl. Range and Pasture Handbook, 1997). An animal unit month is defined as the amount of forage required by one livestock animal, with or without one calf, for one month, and is shortened to AUM.

Plant Community (PC) Production (total lbs./acre in a normal year) and Stocking Rate (AUM/acre) are listed below:

Example:

$1,300 \text{ lbs. per acre} \times 25\% \text{ Harvest Efficiency} = 325 \text{ lbs. forage demand for one month. } 325 \text{ lbs. per acre} / 912 \text{ demand per AUM} = .37$

Reference Plant Community 1000-1600 .35

Heavy Sagebrush 800-1200 .25

Mixed Sagebrush/Grass 800-1200 .25

Blue Grama Sod 600-1000 .1

Increased Bare Ground PC (\*) (\*)

\* Highly variable stocking rates must be determined on-site.

Grazing by domestic livestock is one of the major income-producing industries in the area. Rangelands in this area provide year-long forage under prescribed grazing for cattle, sheep, horses, and other herbivores. During the dormant period, livestock may need supplementation based on reliable forage analysis.

## Hydrological functions

Water is the principal factor limiting forage production on this site. This site is dominated by soils in hydrologic

groups B and C, with localized areas in hydrologic group D. Infiltration ranges from moderate to moderately rapid. Runoff potential for this site varies from moderate to high depending on soil hydrologic group and ground cover. In many cases, areas with greater than 75 percent ground cover have the greatest potential for high infiltration and lower runoff. An example of an exception would be where short-grasses form a strong sod and dominate the site. Areas where ground cover is less than 50 percent have the greatest potential to have reduced infiltration and higher runoff (refer to Part 630, NRCS National Engineering Handbook for detailed hydrology information).

Rills are slight to none, typically on steeper slopes (greater than 15%) and discontinuous. Gullies should not be present. Water flow patterns should be barely distinguishable if at all present. On steeper slopes (greater than 15%), they may be barely visible and discontinuous with numerous debris dams. Pedestalled plants and terracettes are not expected on gentle slopes but will occur on slopes steeper than 15% becoming more evident as slopes increase. Fine litter will generally move short distances (less than 6 inches), some coarse litter will move very short distances (less than 3 inches). Litter debris dams are occasionally present. Chemical and physical crusts are rare to non-existent. Cryptogamic crusts are present, but only cover 1 to 2 percent of the soil surface.

## **Recreational uses**

This site provides hunting opportunities for upland game species. The wide variety of plants which bloom from spring until fall have an esthetic value that appeals to visitors.

## **Wood products**

No appreciable wood products are present on the site.

## **Other products**

None noted.

## **Other information**

Site Development & Testing Plan

General Data (MLRA and Revision Notes, Hierarchical Classification, Ecological Site Concept, Physiographic, Climate, and Water Features, and Soils Data):

Updated. All "Required" items complete to Provisional level.

Community Phase Data (Ecological Dynamics, STM, Transition & Recovery Pathways, Reference Plant Community, Species Composition List, Annual Production Table):

Updated. All "Required" items complete to Provisional level.

Annual Production Table is from the "Previously Approved" ESD (2001).

The Annual Production Table and Species Composition List will be reviewed for future updates at the Approved level.

Each Alternative State/Community:

Complete to Provisional level.

Supporting Information (Site Interpretations, Assoc. & Similar Sites, Inventory Data References, Agency/State Correlation, References):

Updated. All "Required" items complete to Provisional level.

Wildlife Interpretations: Narrative is from "Previously Approved" ESD (2001). Wildlife species will need to be updated at the next Approved level.

Livestock Interpretations: Plant community names and stocking rates updated.

Hydrology, Recreational Uses, Wood Products, and Other Products carried over from previously "Approved" ESD (2001).

Existing NRI Inventory Data References updated. More field data collection is necessary to support this site concept.

#### Reference Sheet

Rangeland Health Reference Sheet carried over from previously "Approved" ESD (2005).

It will be updated at the next "Approved" level.

"Future work, as described in a project plan, to validate the information in this provisional ecological site description is needed. This will include field activities to collect low and medium intensity sampling, soil correlations, and analysis of that data. Annual field reviews should be done by soil scientists and vegetation specialists. A final field review, peer review, quality control, and quality assurance reviews of the ESD will be needed to produce the final document." (NI 430\_306 ESI and ESD, April 2015)

### Inventory data references

Information presented here have been derived from data collection on private and federal lands using:

- Double Sampling \*
- Rangeland Health \*\*
- Soil Stability \*\*
- Line Point Intercept: Foliar canopy, basal cover (Forb, Graminoid, Shrub, Subshrub, Lichen, Moss, Rock fragments, Bare ground, Percentage of Litter) \*\*\*
- Soil pedon descriptions collected on site \*\*\*\*

\* NRCS 528-Prescribed Grazing Standard job sheets.

\*\* Interpreting Indicators of Rangeland Health, Version 4, 2005

\*\*\* Monitoring Manual for Grassland, Shrubland and Savanna Ecosystems, Volume II, 2005

\*\*\*\* Field Book for Describing and Sampling Soils, Version 3, 2012

NRI - Natural Resource Inventory data

SCS-RANGE-417 Production & Composition Record for Native Grazing Lands

Additional reconnaissance data collection using numerous ocular estimates and other inventory data; NRCS clipping data for USDA program support; field observations from experienced range-trained personnel.

Data Source: NRI

Number of Records: 16

Sample Period: 2005-2017

Counties: Campbell, Crook, Johnson, Laramie, Natrona, Niobrara, Sheridan, Weston

### Other references

Anderson, R.C. 2006. Evolution and origin of the central grassland of North America: Climate, fire, and mammalian grazers. *Journal of the Torrey Botanical Society* 133:626–647.

Bragg, T.B. 1995. The physical environment of the Great Plains grasslands. In: A. Joern and K.H. Keeler (eds) *The changing prairie*. Oxford University Press, Oxford, UK, pages 49–81.

Branson, D.H. and G.A. Sword. 2010. An experimental analysis of grasshopper community responses to fire and livestock grazing in a northern mixed-grass prairie. *Environmental Entomology* 39:1441–1446.

Brinson, M.M. 1993. A hydrogeomorphic classification for wetlands. Technical Report WRP–DE–4. U.S. Army Corps of Engineers Waterways Experiment Station, Vicksburg, MS.

Cleland, D., P. Avers, W.H. McNab, M. Jensen, R. Bailey, T. King, and W. Russell. 1997. National hierarchical framework of ecological units. In: *Ecosystem Management: Applications for Sustainable Forest and Wildlife*

Resources, Yale University Press.

Coupland, R.T. 1958. The effects of fluctuations in weather upon the grasslands of the Great Plains. *Botanical Review* 24:273–317.

Davis, S.K., R.J. Fisher, S.L. Skinner, T.L. Shaffer, and R.M. Brigham. 2013. Songbird abundance in native and planted grassland varies with type and amount of grassland in the surrounding landscape. *Journal of Wildlife Management* 77:908–919.

DeLuca, T.H., and P. Lesica. 1996. Long-term harmful effects of crested wheatgrass on Great Plains grassland ecosystems. *Journal of Soil and Water Conservation* 51:408–409.

Derner, J.D. and R.H. Hart. 2007. Grazing-induced modifications to peak standing crop in northern mixed-grass prairie. *Rangeland Ecology and Management* 60:270–276.

Derner, J.D. and A.J. Whitman. 2009. Plant interspaces resulting from contrasting grazing management in northern mixed-grass prairie: Implications for ecosystem function. *Rangeland Ecology and Management* 62:83–88.

Derner, J.D., W.K. Lauenroth, P. Stapp, and D.J. Augustine. 2009. Livestock as ecosystem engineers for grassland bird habitat in the western Great Plains of North America. *Rangeland Ecology and Management* 62:111–118.

Dillehay, T.D. 1974. Late Quaternary bison population changes on the southern Plains. *Plains Anthropologist* 19:180–196.

Dormaar, J.F., and S. Smoliak. 1985. Recovery of vegetative cover and soil organic matter during revegetation of abandoned farmland in a semiarid climate. *Journal of Range Management* 38:487–491.

Guyette, Richard P., M.C. Stambaugh, D.C. Dey, and R.M. Muzika. (2012). Predicting fire frequency with chemistry and climate. *Ecosystems*, 15: 322-335.

Harmoney, K.R. 2007. Grazing and burning Japanese brome (*Bromus japonicus*) on mixed grass rangelands. *Rangeland Ecology and Management* 60:479–486.

Heitschmidt, R.K., and L.T. Vermeire. 2005. An ecological and economic risk avoidance drought management decision support system. In: J.A. Milne (ed.) *Pastoral systems in marginal environments*, 20th International Grasslands Congress, July, 2005. Page 178.

Knopf, F.L. 1996. Prairie legacies—Birds. In: F.B. Samson and F.L. Knopf (eds.) *Prairie conservation: Preserving North America's most endangered ecosystem*. Island Press, Washington, DC. Pages 135–148.

Knopf, F.L., and F.B. Samson. 1997. Conservation of grassland vertebrates. In: F.B. Samson and F.L. Knopf (eds.) *Ecology and conservation of Great Plains vertebrates: Ecological Studies* 125. Springer-Verlag, New York, NY. Pages 273–289.

Lauenroth, W.K., O.E. Sala, D.P. Coffin, and T.B. Kirchner. 1994. The importance of soil water in recruitment of *Bouteloua gracilis* in the shortgrass steppe. *Ecological Applications* 4:741–749.

Laycock, W.A. 1988. History of grassland plowing and grass planting on the Great Plains. In: J.E. Mitchell (ed.) *Impacts of the Conservation Reserve Program in the Great Plains—symposium proceedings*, September 16–18, 1987. U.S. Dept. of Agriculture, Forest Service, Rocky Mountain Forest and Range Experiment Station, General Technical Report RM-158.

Malloch, D.W., K.A. Pirozynski, and P.H. Raven. 1980. Ecological and evolutionary significance of mycorrhizal symbioses in vascular plants (a review). *Proceedings of the National Academy of Sciences* 77:2113–2118.

Ogle, S.M., W.A. Reiners, and K.G. Gerow. 2003. Impacts of exotic annual brome grasses (*Bromus* spp.) on ecosystem properties of the northern mixed grass prairie. *American Midland Naturalist* 149:46–58.

- Roath, L.R. 1988. Implications of land conversions and management for the future. In: J.E. Mitchell (ed.) Impacts of the Conservation Reserve Program in the Great Plains—symposium proceedings, September 16–18, 1987. U.S. Dept. of Agriculture, Forest Service, Rocky Mountain Forest and Range Experiment Station, General Technical Report RM-158.
- Smoliak, S. and J.F. Dormaar. 1985. Productivity of Russian wildrye and crested wheatgrass and their effect on prairie soils. *Journal of Range Management* 38:403–405.
- Smoliak, S., J.F. Dormaar, and A. Johnston. 1972. Long-term grazing effects on *Stipa-Bouteloua* prairie soils. *Journal of Range Management* 25:246–250.
- Soil Survey Division Staff. 2017. Soil survey manual. U.S. Dept. of Agriculture Handbook 18.
- Soil Survey Staff. Official Soil Series Descriptions. U.S. Dept. of Agriculture, Natural Resources Conservation Service. Available online. [https://www.nrcs.usda.gov/wps/portal/nrcs/detail/soils/home/?cid=nrcs142p2\\_053587](https://www.nrcs.usda.gov/wps/portal/nrcs/detail/soils/home/?cid=nrcs142p2_053587) Accessed 15 November, 2017.
- Soil Survey Staff. Soil Survey Geographic (SSURGO) database. U.S. Dept. of Agriculture, Natural Resources Conservation Service.
- Soil Survey Staff. 2014. Keys to Soil Taxonomy, 12th edition. U.S. Dept. of Agriculture, Natural Resources Conservation Service.
- Soil Survey Staff. 2018. Web Soil Survey. U.S. Dept. of Agriculture, Natural Resources Conservation Service. Available online. <https://websoilsurvey.nrcs.usda.gov/app/>. Accessed 15 February, 2018.
- Soller, D.R. 2001. Map showing the thickness and character of Quaternary sediments in the glaciated United States east of the Rocky Mountains. U.S. Geological Survey Miscellaneous Investigations Series I-1970-E, scale 1:3,500,000.
- Stewart, Omer C. 2002. *Forgotten Fires*. Univ. of Oklahoma Press, Norman, OK.
- United States Department of Agriculture, Natural Resources Conservation Service. Glossary of landform and geologic terms. National Soil Survey Handbook, Title 430-VI, Part 629.02c. [http://www.nrcs.usda.gov/wps/portal/nrcs/detail/soils/ref/?cid=nrcs142p2\\_054242](http://www.nrcs.usda.gov/wps/portal/nrcs/detail/soils/ref/?cid=nrcs142p2_054242) (Accessed 16 January, 2018).
- United States Army Corps of Engineers. 1987. Corps of Engineers wetlands delineation manual. Wetlands Research Program Technical Report Y-87-1. Available online. <http://www.lrh.usace.army.mil/Portals/38/docs/USACE%2087%20Wetland%20Delineation%20Manual.pdf>. Waterways Experiment Station, Vicksburg, MS.
- United States Environmental Protection Agency, National Health and Environmental Effects Research Laboratory. 2013. Level III ecoregions of the continental United States. Available online. <https://www.epa.gov/eco-research/ecoregions> Accessed 30 January, 2019.
- United States Department of Agriculture, Natural Resources Conservation Service. 2010a. Field indicators of hydric soils in the United States, version 7.0.
- United States Department of Agriculture, Natural Resources Conservation Service. 2013a. Climate data. National Water and Climate Center. Available online. <http://www.wcc.nrcs.usda.gov/climate>. Accessed 13 October, 2017.
- United States Department of Agriculture, Natural Resources Conservation Service. 2006. Land resource regions and major land resource areas of the United States, the Caribbean, and the Pacific Basin. Agriculture Handbook 296.
- United States Department of Agriculture, Natural Resources Conservation Service. 2013b. National Soil Information System. Available online. [https://www.nrcs.usda.gov/wps/portal/nrcs/detail/soils/survey/geo/?cid=nrcs142p2\\_053552](https://www.nrcs.usda.gov/wps/portal/nrcs/detail/soils/survey/geo/?cid=nrcs142p2_053552). Accessed 30 October, 2017.

- United States Department of the Interior, Geological Survey. 2008. LANDFIRE 1.1.0 Vegetation Dynamics Models. <http://landfire.cr.usgs.gov/viewer/>.
- United States Department of the Interior, Geological Survey. 2011. LANDFIRE 1.1.0 Existing Vegetation Types. <http://landfire.cr.usgs.gov/viewer/>.
- Willeke, G.E. 1994. The national drought atlas [CD ROM]. U.S. Army Corps of Engineers, Water Resources Support Center, Institute for Water Resources Report 94-NDS-4.
- Wilson, S.D., and J.M. Shay. 1990. Competition, fire, and nutrients in a mixed-grass prairie. *Ecology* 71:1959–1967.
- With, K.A. 2010. McCown's longspur (*Rhynchophanes mccownii*). In: A. Poole (ed.) *The birds of North America* [online]. Cornell Lab of Ornithology, Ithaca, NY. <https://birdsna.org/Species-Account/bna/home>.
- Augustine, D.J., J. Derner, D. Milchunas, D. Blumenthal, and L. Porensky. 2017. Grazing moderates increases in C3 grass abundance over seven decades across a soil texture gradient in shortgrass steppe. In: *Journal of Vegetation Science*, DOI:10.1111/jvs.12508.
- Clark, J., E. Grimm, J. Donovan, S. Fritz, D. Engrstrom, and J. Almendinger. 2002. Drought cycles and landscape responses to past aridity on prairies of the Northern Great Plains, USA. *Ecology*, 83(3), Pages 595-601.
- Connell, L. C., J. D. Scasta, and L. M. Porensky. 2018. Prairie dogs and wildfires shape vegetation structure in a sagebrush grassland more than does rest from ungulate grazing. *Ecosphere* 9(8):e02390. 10.1002/ecs2.2390
- Collins, S. and S. Barber. (1985). Effects of disturbance on diversity in mixed-grass prairie. In: *Vegetatio*, 64, pages 87-94.
- Egan, Timothy. 2006. *The Worst Hard Time*. Houghton Mifflin Harcourt Publishing Company, New York, NY.
- Guyette, R.P., M.C. Stambaugh, D.C. Dey, and R.M. Muzika. 2012. Predicting fire frequency with chemistry and climate. In: *Ecosystems*, 15: pages 322-335.
- Hart, R. and J. Hart. 1997. Rangelands of the Great Plains before European settlement. In: *Rangelands*, 19(1), pages 4-11.
- Hart, R. 2001. Plant biodiversity on shortgrass steppe after 55 years of zero, light, moderate, or heavy cattle grazing. In: *Plant Ecology*, 155, pages 111-118.
- Pellant, M., P. Shaver, D.A. Pyke, and J.E. Herrick. 2005. Interpreting indicators of rangeland health, Version 4. United States Department of the Interior, Bureau of Land Management.
- Porensky, L.M. and D.M. Blumenthal. 2016. Historical wildfires do not promote cheatgrass invasion in a western Great Plains steppe. In: *Biological Invasions* 18:3333-3349: DOI 10.1007/s10530-16-1225-z
- Porensky, L.M., J.D. Derner, and D.W. Pellatz. 2018. Plant community responses to historical wildfire in a shrubland-grassland ecotone reveal hybrid disturbance response. In: *Ecosphere*. DOI: 9(8):e02363. 10.1002/ecs2.2363.
- Mack, Richard N., and J.N. Thompson. 1982. Evolution in steppe with few large, hooved mammals. In: *The American Naturalist*. 119, No. 6, pages 757-773.
- Reyes-Fox, M., H. Stelzer, M.J. Trlica, G.S. McMaster, A. A. Andales, D.R. LeCain, and J.A. Morgan. 2014. Elevated CO2 further lengthens growing season under warming conditions. In: *Nature*, April 23, 2014. Available online. <http://www.nature.com/nature/journal/v510/n7504/full/nature13207.html>. Accessed 1 March, 2017.
- Schoeneberger, P.J., D.A. Wysockie, E.C. Benham, and Soil Survey Staff. 2012. *Field book for describing and sampling soils*, Version 3.0. U.S. Dept. of Agriculture, Natural Resources Conservation Service.



Stahl, David W., E.R. Cook, M.K. Cleaveland, M.D. Therrell, D.M. Meko, H.D. Grissino-Mayer, E. Watson, and B.H. Luckman. Tree-ring data document 16th century megadrought over North America. 2000. In: *Eos*, 81(12), pages 121-125.

Stubbenieck, James, S.L. Hatch, and L.M. Landholt. 2003. *North American wildland plants*. Univ. of Nebraska Press, Lincoln and London.

Zelikova, T.J., D.M. Blumenthal, D.G. Williams, L. Souza, D.R. LeCain, and J. Morgan. 2014. Long-term exposure to elevated CO<sub>2</sub> enhances plant community stability by suppressing dominant plant species in a mixed-grass prairie. In: *Ecology*, 2014. Available online. <https://www.pnas.org/content/111/43/15456>.

United States Department of Agriculture, Natural Resources Conservation Service. *National Ecological Site Handbook*, Title 190, Part 630, 1st Edition. Available online. <https://directives.sc.egov.usda.gov/>. Accessed 15 September, 2017.

United States Department of Agriculture, Natural Resources Conservation Service. 2009. Part 630, Hydrology, *National Engineering Handbook*.

United States Department of Agriculture, Natural Resources Conservation Service. 1972-2012. *National Engineering Handbook Hydrology Chapters*. <http://www.nrcs.usda.gov/wps/portal/nrcs/detailfull/national/water/?&cid=stelprdb1043063> (Accessed August, 2015).

United States Department of Agriculture, Natural Resources Conservation Service. 1997, revised 2003. *National Range and Pasture Handbook*. Available online. <http://www.glti.nrcs.usda.gov/technical/publications/nrph.html> Accessed 26 February, 2018.

United States Department of Agriculture, Natural Resources Conservation Service. *National Soil Survey Handbook title 430-VI*. Available online. [http://www.nrcs.usda.gov/wps/portal/nrcs/detail/soils/ref/?cid=nrcs142p2\\_054242](http://www.nrcs.usda.gov/wps/portal/nrcs/detail/soils/ref/?cid=nrcs142p2_054242).

United States Department of Agriculture, Natural Resources Conservation Service. *Web Soil Survey*. Available online. <http://websoilsurvey.sc.egov.usda.gov/App/WebSoilSurvey.aspx>. Accessed 15 November, 2017.

United States Department of Commerce, National Oceanic and Atmospheric Administration (NOAA). *Cooperative climatological data summaries*. NOAA Western Regional Climate Center, Reno, NV. Available online. <http://www.wrcc.dri.edu/climatedata/climsum>. Accessed 16 November, 2017.

## **Contributors**

Everett Bainter  
Glenn Mitchell

## **Approval**

Kirt Walstad, 10/04/2023

## **Acknowledgments**

Project Staff:

Kimberly Diller, Ecological Site Inventory Specialist, NRCS MLRA SSO, Pueblo CO  
Mike Leno, Project Leader, NRCS MLRA SSO, Buffalo, WY

Partners/Contributors:

Joe Dyer, Soil Scientist, NRCS MLRA SSO, Buffalo, WY  
Arnie Irwin, Soil Scientist, BLM, Buffalo, WY  
Blaine Horn, Rangeland Extension Educator, UW Extension, Buffalo, WY  
Isabelle Giuliani, Resource Soil Scientist, NRCS, Douglas, WY  
Mary Jo Kimble, Project Leader, NRCS MLRA SSO, Miles City, MT

Ryan Murray, Rangeland Management Specialist, NRCS, Buffalo, WY  
 Lauren Porensky, Ph.D., Ecologist, ARS, Fort Collins, CO  
 Chadley Prosser, Rangeland Program Manager, USFS, Bismarck, ND  
 Bryan Christensen, Ecological Site Inventory Specialist, NRCS-MLRA SSO, Pinedale, WY  
 Marji Patz, Ecological Site Inventory Specialist, NRCS-MLRA SSO, Powell, WY  
 Rick Peterson, Ecological Site Inventory Specialist, NRCS-MLRA SSO, Rapid City, SD

Program Support:

John Hartung, WY State Rangeland Management Specialist-QC, NRCS, Casper, WY  
 David Kraft, NRCS MLRA Ecological Site Inventory Specialist-QA, Emporia, KS  
 Carla Green Adams, Editor, NRCS-SSR5, Denver, CO  
 Chad Remley, Regional Director, Northern Great Plains Soil Survey, Salina, KS

**Rangeland health reference sheet**

Interpreting Indicators of Rangeland Health is a qualitative assessment protocol used to determine ecosystem condition based on benchmark characteristics described in the Reference Sheet. A suite of 17 (or more) indicators are typically considered in an assessment. The ecological site(s) representative of an assessment location must be known prior to applying the protocol and must be verified based on soils and climate. Current plant community cannot be used to identify the ecological site.

Author(s)/participant(s)	
Contact for lead author	
Date	04/01/2005
Approved by	Kirt Walstad
Approval date	
Composition (Indicators 10 and 12) based on	Annual Production

**Indicators**

1. **Number and extent of rills:** Rills should not be present

---

2. **Presence of water flow patterns:** Barely observable

---

3. **Number and height of erosional pedestals or terracettes:** Essentially non-existent

---

4. **Bare ground from Ecological Site Description or other studies (rock, litter, lichen, moss, plant canopy are not bare ground):** Bare ground is 45-55% occurring in small areas throughout site

---

5. **Number of gullies and erosion associated with gullies:** Active gullies should be restricted to areas of concentrated water flow patterns on steeper slopes

---

6. **Extent of wind scoured, blowouts and/or depositional areas:** Small scoured sites may be observed

---

7. **Amount of litter movement (describe size and distance expected to travel):** Litter movement is little to none based on topography and water flow patterns
- 
8. **Soil surface (top few mm) resistance to erosion (stability values are averages - most sites will show a range of values):** Plant cover and litter is at 55% or greater of soil surface and maintains soil surface integrity. Soil Stability class is anticipated to be 4 or greater.
- 
9. **Soil surface structure and SOM content (include type of structure and A-horizon color and thickness):** Use Soil Series description for depth and color of A-horizon
- 
10. **Effect of community phase composition (relative proportion of different functional groups) and spatial distribution on infiltration and runoff:** Grass canopy and basal cover should reduce raindrop impact and slow overland flow providing increased time for infiltration to occur. Infiltration is moderate.
- 
11. **Presence and thickness of compaction layer (usually none; describe soil profile features which may be mistaken for compaction on this site):** No compaction layer or soil surface crusting should be present.
- 
12. **Functional/Structural Groups (list in order of descending dominance by above-ground annual-production or live foliar cover using symbols: >>, >, = to indicate much greater than, greater than, and equal to):**
- Dominant:
- Sub-dominant:
- Other:
- Additional: Mid stature Cool Season Grasses > Short Grasses/Grasslikes Mid Stature Warm Season Grasses Shrubs Forbs
- 
13. **Amount of plant mortality and decadence (include which functional groups are expected to show mortality or decadence):** Very Low
- 
14. **Average percent litter cover (%) and depth ( in):** Average litter cover is 20-30% with depths of 0.25 to 0.5 inches
- 
15. **Expected annual annual-production (this is TOTAL above-ground annual-production, not just forage annual-production):** 1300 lbs./ac
- 
16. **Potential invasive (including noxious) species (native and non-native). List species which BOTH characterize degraded states and have the potential to become a dominant or co-dominant species on the ecological site if their future establishment and growth is not actively controlled by management interventions. Species that become dominant for only one to several years (e.g., short-term response to drought or wildfire) are not**

**invasive plants. Note that unlike other indicators, we are describing what is NOT expected in the reference state for the ecological site:** Blue grama, Threadleaf sedge, Prickly Pear, Broom Snakeweed, and Species found on Noxious Weed List

---

17. **Perennial plant reproductive capability:** All species are capable of reproducing

---