

Ecological site R060AY012SD Thin Upland

Last updated: 6/25/2024
Accessed: 03/13/2026

General information

Provisional. A provisional ecological site description has undergone quality control and quality assurance review. It contains a working state and transition model and enough information to identify the ecological site.

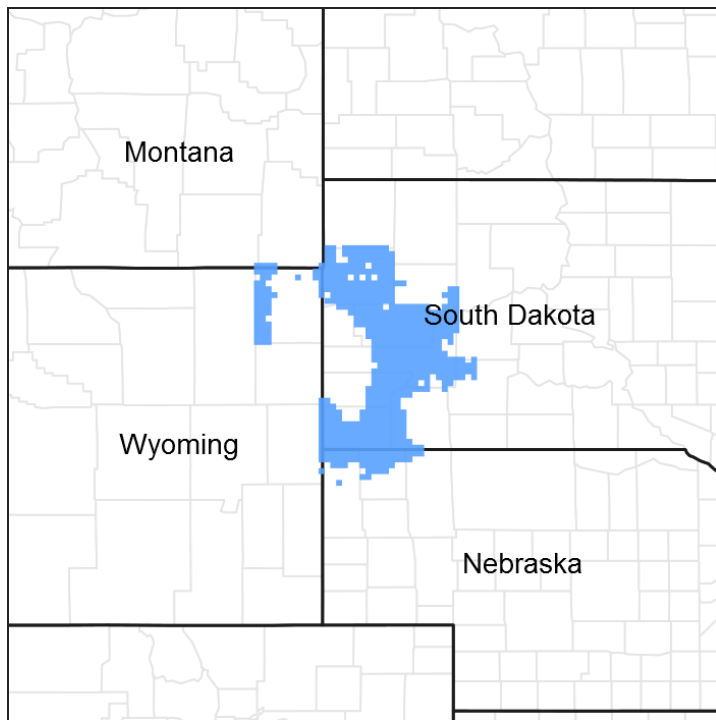

Figure 1. Mapped extent

Areas shown in blue indicate the maximum mapped extent of this ecological site. Other ecological sites likely occur within the highlighted areas. It is also possible for this ecological site to occur outside of highlighted areas if detailed soil survey has not been completed or recently updated.

MLRA notes

Major Land Resource Area (MLRA): 060A–Pierre Shale Plains

The Pierre Shale Plains (MLRA 60A) consists of approximately 10,150 square miles, the majority of which is located in South Dakota (70 percent) and small portions are in

Montana (2 percent), Nebraska (8 percent), and Wyoming (20 percent). It encircles the Black Hills (MLRA 62) and the Dakota Hogback (MLRA 61). MLRA 60A includes portions of the Oglala, Buffalo Gap, and Thunder Basin National Grasslands. It also includes small sections of the Pine Ridge Indian Reservation, Badlands National Park, and Black Hills National Forest. The Cheyenne and Belle Fourche Rivers flow through the MLRA.

MLRA 60A is in the unglaciated section of the Missouri Plateau, of the Great Plains Province of the Interior Plains. It is an area of old plateaus and terraces that have been deeply eroded. Cretaceous Pierre Shale underlies almost all of this MLRA. This is a marine sediment with layers of volcanic ash that has been altered to smectitic clay. These clays shrink as they dry and swell as they receive moisture. Soils are shallow to very deep and generally are well drained and clayey.

Elevations generally range from 2,620 to 3,610 feet throughout the MLRA, but can range up to 4,260 feet. The average annual precipitation for the western side of the MLRA is 13 to 16 inches, whereas the eastern side receives 16 to 18 inches. A suite of ecological sites has been written specifically for these two precipitation zones. The Locator Map shows the break between the two precipitation zones.

This area supports a mixed natural prairie vegetation consisting of both cool- and warm-season grasses and forbs. Wyoming big sagebrush occurs primarily in the drier western portion of the MLRA, however, small remnant stands can be found in the eastern portion. Dominant land uses of the area are primarily ranching and, to a lesser extent, farming. Major resource concerns to this MLRA are wind erosion and surface water quality.

Classification relationships

USDA - Land Resource Region G – Western Great Plains Range and Irrigated Region, Major Land Resource Area (MLRA) 60A – Pierre Shale Plains.

EPA - Level IV Ecoregions of the Continental United States: 43e – Sagebrush Steppe, 43g Semiarid Pierre Shale Plains, and 43k – Dense Clay Prairie.

Ecological site concept

The Thin Upland site occurs throughout MLRA 60A. It is located on upland landscapes, is a runoff site, and does not receive additional water from runoff or overflow. The typical slopes range from 6 to 45 percent. The soils are deep to very deep, exceeding 20 inches in depth. The surface layer, or “A” horizon, is typically less than 3 inches in depth with a loam to silty clay loam texture. Carbonates are almost always present at or near the soil surface (within 6 inches).

The vegetation in the Reference Plant Community consists of a mix of cool- and warm-season grasses. Forbs are common and diverse but never dominant; shrubs can be present but in minor or trace amounts. Little bluestem, needle and thread, sideoats grama,

and blue grama are the primary grasses in this ecological site. Other species will include western wheatgrass, sedge, and prairie Junegrass. In the western portion of the MLRA, bluebunch wheatgrass may also occur in significant amounts and compete with little bluestem. Purple coneflower (Echinacea) is almost always present in significant amounts. Dominant shrubs will include fringed sagewort, rose, and yucca.

Associated sites

R060AY010SD	Loamy 13-16" P.Z. The Loamy 13-16" site may occur on gentle slopes adjacent to the Thin Upland site.
R060AY011SD	Clayey 13-16" P.Z. The Clayey 13-16" site may occur on gentle slopes adjacent to the Thin Upland site.
R060AY024SD	Shallow Loamy The Shallow Loamy site may occur on shallow soils with steeper slopes, adjacent to the Thin Upland site.
R060AY040SD	Clayey 16-18" P.Z. The Clayey 16-18" site may occur on gentle slopes adjacent to the Thin Upland site.
R060AY041SD	Loamy 16-18" P.Z. The Loamy 16-18" site may occur on gentle slopes adjacent to the Thin Upland site.

Similar sites

R060AY024SD	Shallow Loamy Less little bluestem; soils shallow to rock, gravel or other root-restrictive layer (20 inches or less)
-------------	---

Table 1. Dominant plant species

Tree	Not specified
Shrub	Not specified
Herbaceous	(1) <i>Schizachyrium scoparium</i>

Physiographic features

This site occurs on gently sloping to very steep uplands.

Table 2. Representative physiographic features

Landforms	(1) Hill (2) Ridge (3) Knoll
Flooding frequency	None
Ponding frequency	None
Elevation	2,500–4,300 ft
Slope	2–45%
Ponding depth	0 in
Water table depth	0 in
Aspect	Aspect is not a significant factor

Climatic features

The climate in this MLRA is typical of the drier portions of the Northern Great Plains, where sagebrush steppes to the west yield to grassland steppes to the east. Annual precipitation for the entire MLRA ranges from 13 to 18 inches per year, with most occurring during the growing season. Temperatures show a wide range between summer and winter and between daily maximums and minimums, due to the high elevation and dry air, which permits rapid incoming and outgoing radiation. Cold air masses from Canada in winter move rapidly from northwest to southeast and account for extreme minimum temperatures. Chinook winds may occur in winter and bring rapid rises in temperature. Extreme storms may occur during the winter, but the more severe occur during late fall, late winter, and spring.

The normal average annual temperature is about 46°F. January is the coldest month with average temperatures ranging from about 19°F (Moorcroft CAA, WY) to about 22°F (Belle Fourche, SD). July is the warmest month with temperatures averaging from about 70°F (Moorcroft CAA, WY) to about 72°F (Belle Fourche, SD). The range of normal average monthly temperatures between the coldest and warmest months is about 51°F. Hourly winds are estimated to average about 11 miles per hour annually, ranging from about 13 miles per hour during the spring to about 10 miles per hour during the summer. Daytime winds generally are stronger than nighttime, and occasional strong storms may bring brief periods of high winds with gusts to more than 50 miles per hour.

Growth of cool-season plants begins in early to mid-March, slowing or ceasing in late June. Warm-season plants begin growth about mid-May and can continue to early or mid-September. Green-up of cool-season plants may occur in September and October when adequate soil moisture is present.

Table 3. Representative climatic features

Frost-free period (characteristic range)	98-105 days
--	-------------

Freeze-free period (characteristic range)	123-129 days
Precipitation total (characteristic range)	15-18 in
Frost-free period (actual range)	76-108 days
Freeze-free period (actual range)	113-133 days
Precipitation total (actual range)	14-18 in
Frost-free period (average)	97 days
Freeze-free period (average)	124 days
Precipitation total (average)	16 in

Climate stations used

- (1) BELLE FOURCHE [USC00390559], Belle Fourche, SD
- (2) ARDMORE 1 NW [USC00390236], Edgemont, SD
- (3) WASTA [USC00398911], Owanka, SD
- (4) UPTON [USC00489205], Upton, WY
- (5) REDBIRD [USC00487555], Lance Creek, WY
- (6) MOORCROFT 3S [USW00024088], Moorcroft, WY

Influencing water features

No significant water features influence this site.

Wetland description

Not Applicable.

Soil features

The soils in this site are well drained and formed in soft siltstone, sandstone, or loess deposits. The loam to silty clay loam surface layer is 4 to 7 inches thick. The soils have a moderate to moderately slow infiltration rate. These soils are typically calcareous at or near the surface; however, carbonates are not always distinguishable in the upper layers. The soil profile should show evidence of weak development (i.e., thin A horizon, pale colors, lack of argillic horizon). This site should show slight to no evidence of rills or wind-scoured areas. It is not uncommon to have some pedestalling of plants due to the inherent instability of the soils. Water flow paths are broken, irregular in appearance, or discontinuous with numerous debris dams or vegetative barriers. The soil surface is stable and intact. Subsurface soil layers are slightly restrictive to water movement and root penetration.

These soils are highly susceptible to water erosion and to a lesser degree wind erosion.

The hazard of water erosion increases where vegetative cover is not adequate.

Soils correlated to the Thin Upland site include: Colby, Fairburn, Manvel, Minnequa, Nevee, Ziggy, and Zigweed.

More information can be found in the various soil survey reports. Contact the local USDA Service Center for soil survey reports that include more detail specific to your location.

Table 4. Representative soil features

Surface texture	(1) Silt loam (2) Silty clay loam (3) Clay loam
Family particle size	(1) Loamy
Drainage class	Well drained
Permeability class	Slow to moderate
Soil depth	20–80 in
Surface fragment cover ≤3"	0%
Surface fragment cover >3"	0%
Available water capacity (0-40in)	5–6 in
Calcium carbonate equivalent (0-40in)	0–30%
Electrical conductivity (0-40in)	0–8 mmhos/cm
Sodium adsorption ratio (0-40in)	0–4
Soil reaction (1:1 water) (0-40in)	6.6–8.4
Subsurface fragment volume ≤3" (Depth not specified)	0–20%
Subsurface fragment volume >3" (Depth not specified)	0–10%

Ecological dynamics

This site developed under Northern Great Plains climatic conditions, natural influences of large herbivores, occasional fire, and other biotic and abiotic factors that typically influence soil/site development. Changes will occur in the plant communities due to short-term weather variations, impacts of native and/or exotic plant and animal species, and

management actions. While the following plant community descriptions specify more typical transitions between communities that will occur, severe disturbances, such as periods of well-below average precipitation, can cause significant shifts in plant communities and/or species composition.

Encroachment of, Rocky Mountain juniper, eastern redcedar, and ponderosa pine may occur from adjacent sites, and can shift site characteristics. These shifts can alter the site dynamics and potential. These species may occur in small amounts on several plant communities.

The plant community upon which interpretations are primarily based is the Little Bluestem-Needlegrass-Grama Plant Community (1.1). This Plant Community Phase (PCP) is considered to be the Reference Plant Community. This community has been determined by studying rangeland relic areas, areas protected from excessive disturbance, and areas under long-term rotational grazing regimes. Trends in plant community dynamics ranging from heavily grazed to lightly grazed areas, seasonal use pastures, and historical accounts also have been used. Plant communities, states, transitional pathways, and thresholds have been determined through similar studies and experience.

The following is a diagram that illustrates the common plant communities that can occur on the site and the transition pathways between communities. The ecological processes are discussed in more detail in the plant community descriptions following the diagram.

State and transition model

Thin Upland – R060AY012SD 4/27/17

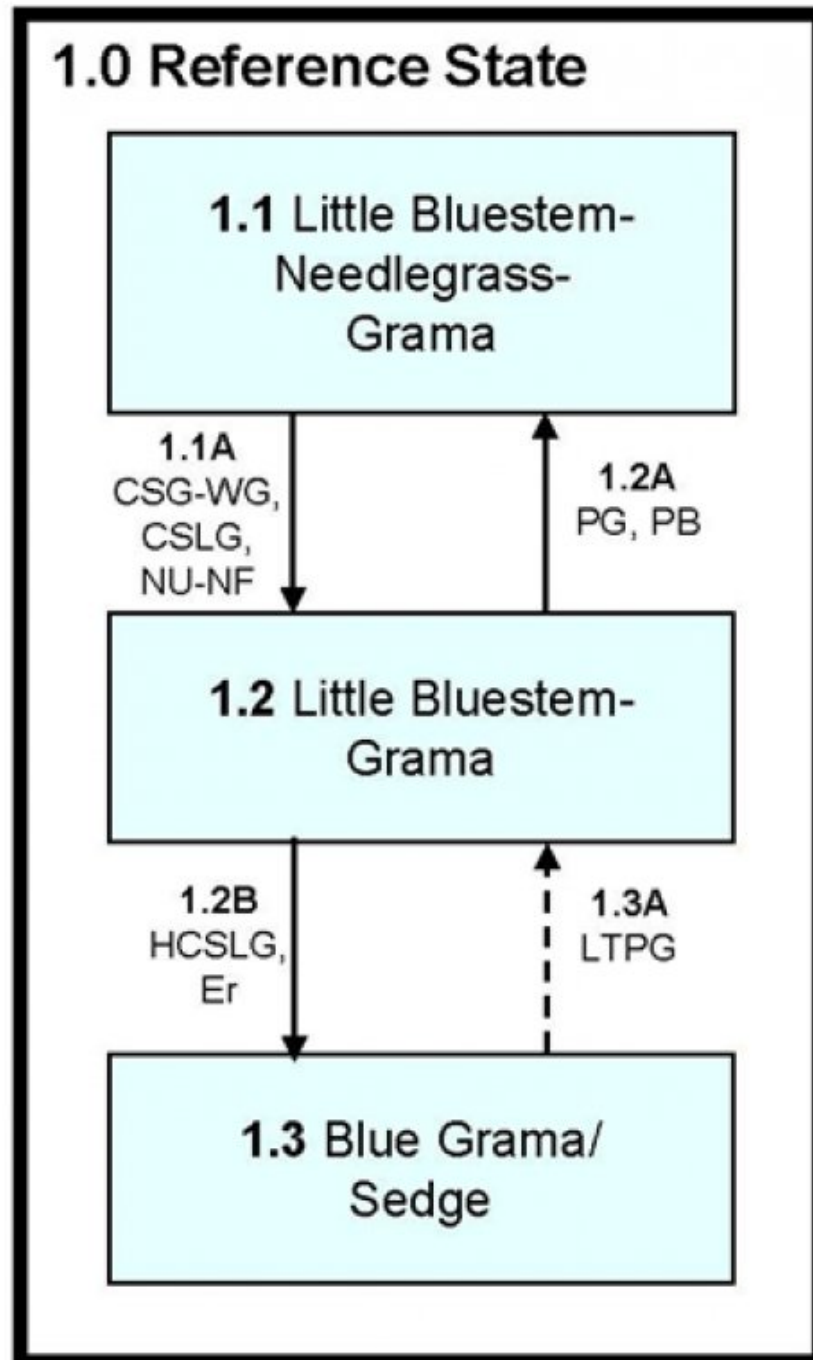

- CSG – Continuous seasonal grazing
- CSLG – Continuous season-long grazing
- Er – Erosion
- HCSLG – Heavy continuous season-long grazing
- LTPG – Long-term prescribed grazing
- NF – No fire
- NU – Non-use
- PB – Prescribed burning
- PG – Prescribed grazing
- WG – Winter grazing
- > Transition may not be fast and/or feasible

Figure 8. Thin Upland - R060AY012SD

CP 1.1A	1.1 - 1.2	Continuous seasonal grazing without change in season of use, winter grazing that expends in the early portion of the growing season, or continuous season-long grazing, or non-use and no fire.
CP 1.2A	1.2 - 1.1	Prescribed grazing including change in season of use, proper stocking and adequate time for rest and recovery, or prescribed burning followed by prescribed grazing.
CP 1.2B	1.2 - 1.3	Heavy, continuous season-long grazing, increased erosion.
CP 1.3A	1.3 - 1.2	Long-term prescribed grazing that includes proper stocking, change in season of use, and adequate recovery.

Figure 9. Thin Upland - R060AY012SD

State 1 Reference State

This state represents what is believed to represent the natural range of variability that dominated the dynamics in this ecological site prior to European settlement. This site is dominated by cool- and warm-season grasses. In pre-European times the primary disturbances included fire and grazing by large ungulates and small mammals. Favorable growing conditions occurred during the spring and the warm months of June through August. This State can be found on areas having a history of proper grazing management, including adequate recovery periods between grazing events.

Community 1.1 Little Bluestem-Needlegrass-Grama



Figure 10. Plant Community Phase 1.1.

The plant community upon which interpretations are primarily based is the Little Bluestem-Needlegrass-Grama Plant Community. This is also considered to be the Reference Plant Community. This plant community can be found on areas that are properly managed with grazing and/or prescribed burning, and on areas receiving occasional short periods of deferment. The potential vegetation is about 75 to 85 percent grasses or grass-like plants, 5 to 15 percent forbs, and 5 to 10 percent shrubs. A mixture of cool- and warm- season grasses dominate the plant community. Major grasses include little bluestem, needle and thread, sideoats grama, and blue grama. Other grasses and grass-likes occurring include sedge, western wheatgrass, green needlegrass, and prairie Junegrass. Significant forbs include purple coneflower, dotted gayfeather, and prairie clover. Significant shrubs found in this plant community include fringed sagewort, rose, and yucca. This plant community is extremely resilient and well adapted to the Northern Great Plains climatic conditions. The diversity in plant species allows for high drought tolerance. Community dynamics, nutrient cycle, water cycle, and energy flow are functioning properly. Plant litter is properly distributed with very little movement off-site and natural plant mortality is very low. The diversity in plant species allows for high drought tolerance.

Table 5. Annual production by plant type

Plant Type	Low (Lb/Acre)	Representative Value (Lb/Acre)	High (Lb/Acre)
Grass/Grasslike	870	1155	1540
Forb	65	140	215
Shrub/Vine	65	105	145
Total	1000	1400	1900

Figure 12. Plant community growth curve (percent production by month). SD6003, Pierre Shale Plains, cool-season/warm-season co-dominant.. Cool-season, warm-season co-dominant.

Jan	Feb	Mar	Apr	May	Jun	Jul	Aug	Sep	Oct	Nov	Dec
0	0	3	10	20	28	21	10	5	3	0	0

Community 1.2 Little Bluestem-Grama

This plant community develops under continuous seasonal grazing or continuous season-long grazing and a low fire frequency. This plant community can also result from extended periods of non-use and no fire. Little bluestem dominates this plant community, as it takes advantage of soil disturbance (resulting from hoof action, or increased bare ground due to reduced plant vigor under non-use and no fire). Other significant grasses or grass-likes include blue grama, sideoats grama, and sedge. Forbs commonly found in this plant community include cudweed sagewort, purple coneflower, and dotted gayfeather. Significant shrubs include fringed sagewort and rose. The potential vegetation is about 80 to 90 percent grasses or grass-like plants, 5 to 10 percent forbs, and 5 to 10 percent

shrubs. Although production remains relatively high, little bluestem plants often become “wolfy,” or older and coarse, and largely unavailable to most herbivores. This plant community is moderately resistant to change. The herbaceous species present are well adapted to grazing; however, species composition can be altered through long-term overgrazing. If the herbaceous component is intact, it tends to be resilient if the disturbance is not long-term.

Table 6. Annual production by plant type

Plant Type	Low (Lb/Acre)	Representative Value (Lb/Acre)	High (Lb/Acre)
Grass/Grasslike	690	1020	1450
Forb	55	90	125
Shrub/Vine	55	90	125
Total	800	1200	1700

Figure 14. Plant community growth curve (percent production by month). SD6005, Pierre Shale Plains, warm-season dominant. Warm-season dominant..

Jan	Feb	Mar	Apr	May	Jun	Jul	Aug	Sep	Oct	Nov	Dec
0	0	2	5	15	25	30	15	7	1	0	0

Community 1.3 Blue Grama/Sedge



Figure 15. Plant Community Phase 1.3.

This plant community is a result from heavy grazing over many years. Diversity is diminished, as the short grasses become dominant in the plant community. The grazing-tolerant blue grama and sedges replace little bluestem and needlegrasses. Sideoats

grama remains in the plant community, but is less productive because of competition and grazing pressure. Due to low palatability, cudweed sagewort, milkvetch, heath aster, and green sagewort become more prevalent in the plant community. Fringed sagewort is the dominant shrub in this plant community. The potential vegetation is about 75 to 85 percent grasses or grass-like plants, 5 to 15 percent forbs, and 5 to 10 percent shrubs. This plant community is resistant to change. The herbaceous species present are less palatable than the dominant species in the Reference Plant Community (1.1).

Table 7. Annual production by plant type

Plant Type	Low (Lb/Acre)	Representative Value (Lb/Acre)	High (Lb/Acre)
Grass/Grasslike	330	660	990
Forb	35	80	125
Shrub/Vine	35	60	85
Total	400	800	1200

Figure 17. Plant community growth curve (percent production by month). SD6004, Pierre Shale Plains, warm-season dominant, cool-season sub-dominant. Warm season dominant, cool-season sub-dominant.

Jan	Feb	Mar	Apr	May	Jun	Jul	Aug	Sep	Oct	Nov	Dec
0	0	3	7	18	25	25	15	7	0	0	0

Pathway 1.1A Community 1.1 to 1.2

Continuous seasonal grazing (early season grazing with high stock densities results in increased soil disturbance, which favors the little bluestem), winter grazing that extends in the early part of the growing season, or continuous season-long grazing (low to moderate stocking rates resulting in patch grazing) will convert this plant community to the Little Bluestem-Grama Plant Community (1.2). Non-use and no fire can also shift this plant community to the Little Bluestem-Grama Plant Community (1.2).

Pathway 1.2A Community 1.2 to 1.1

Prescribed grazing or prescribed burning followed by prescribed grazing will convert this plant community to the Little Bluestem-Needlegrass-Grama Plant Community (1.1).

Pathway 1.2B Community 1.2 to 1.3

Heavy, continuous grazing and erosion resulting in an increase in bare ground will convert the plant community to the Blue Grama/Sedge Plant Community (1.3).

Pathway 1.3A

Community 1.3 to 1.2

Long-term prescribed grazing that includes changing season of use and allowing adequate recovery periods will slowly lead this plant community back to the Little Bluestem-Grama Plant Community (1.2).

Additional community tables

Table 8. Community 1.1 plant community composition

Group	Common Name	Symbol	Scientific Name	Annual Production (Lb/Acre)	Foliar Cover (%)
Grass/Grasslike					
1	Little Bluestem			140–490	
	little bluestem	SCSC	<i>Schizachyrium scoparium</i>	140–490	–
2	Sideoats Grama			70–280	
	sideoats grama	BOCU	<i>Bouteloua curtipendula</i>	70–280	–
3	Needlegrass			140–280	
	needle and thread	HECOC8	<i>Hesperostipa comata</i> <i>ssp. comata</i>	140–210	–
	porcupinegrass	HESP11	<i>Hesperostipa spartea</i>	0–70	–
	green needlegrass	NAVI4	<i>Nassella viridula</i>	0–70	–
4	Short Warm Season			140–280	
	blue grama	BOGR2	<i>Bouteloua gracilis</i>	140–280	–
	hairy grama	BOHI2	<i>Bouteloua hirsuta</i>	0–70	–
	buffalograss	BODA2	<i>Bouteloua dactyloides</i>	0–70	–
5	Native Grasses			140–350	
	western wheatgrass	PASM	<i>Pascopyrum smithii</i>	70–210	–
	bluebunch wheatgrass	PSSP6	<i>Pseudoroegneria spicata</i>	0–150	–
	big bluestem	ANGE	<i>Andropogon gerardii</i>	0–140	–
	sedge	CAREX	<i>Carex</i>	70–140	–
	prairie Junegrass	KOMA	<i>Koeleria macrantha</i>	14–70	–
	plains muhly	MUCU3	<i>Muhlenbergia cuspidata</i>	0–70	–
	prairie sandreed	CALO	<i>Calamovilfa longifolia</i>	0–70	–

	Grass, perennial	2GP	<i>Grass, perennial</i>	0–70	–
	Sandberg bluegrass	POSE	<i>Poa secunda</i>	0–42	–
Forb					
7	Forbs			70–210	
	blacksamson echinacea	ECAN2	<i>Echinacea angustifolia</i>	28–140	–
	prairie clover	DALEA	<i>Dalea</i>	14–70	–
	dotted blazing star	LIPU	<i>Liatris punctata</i>	28–70	–
	Cuman ragweed	AMPS	<i>Ambrosia psilostachya</i>	14–70	–
	tarragon	ARDR4	<i>Artemisia dracunculus</i>	0–70	–
	milkvetch	ASTRA	<i>Astragalus</i>	14–70	–
	false boneset	BREU	<i>Brickellia eupatorioides</i>	0–70	–
	scarlet globemallow	SPCO	<i>Sphaeralcea coccinea</i>	14–70	–
	white sagebrush	ARLU	<i>Artemisia ludoviciana</i>	14–56	–
	Forb, perennial	2FP	<i>Forb, perennial</i>	0–42	–
	scarlet beeblossom	OESU3	<i>Oenothera suffrutescens</i>	14–42	–
	purple prairie clover	DAPU5	<i>Dalea purpurea</i>	0–42	–
	hairy false goldenaster	HEVI4	<i>Heterotheca villosa</i>	0–28	–
	large Indian breadroot	PEES	<i>Pediomelum esculentum</i>	0–28	–
	beardtongue	PENST	<i>Penstemon</i>	0–28	–
	spiny phlox	PHHO	<i>Phlox hoodii</i>	0–28	–
	scurfpea	PSORA2	<i>Psoralegium</i>	0–28	–
	goldenrod	SOLID	<i>Solidago</i>	0–28	–
	buttecandle	CRCE	<i>Cryptantha celosioides</i>	0–28	–
	pussytoes	ANTEN	<i>Antennaria</i>	0–28	–
	white heath aster	SYER	<i>Symphotrichum ericoides</i>	0–28	–
	sego lily	CANU3	<i>Calochortus nuttallii</i>	0–14	–
Shrub/Vine					
8	Shrubs			70–140	

	leadplant	AMCA6	<i>Amorpha canescens</i>	0–70	–
	prairie sagewort	ARFR4	<i>Artemisia frigida</i>	28–70	–
	rose	ROSA5	<i>Rosa</i>	0–70	–
	soapweed yucca	YUGL	<i>Yucca glauca</i>	0–70	–
	Subshrub (<.5m)	2SUBS	<i>Subshrub (<.5m)</i>	0–42	–
	skunkbush sumac	RHTR	<i>Rhus trilobata</i>	0–28	–
	dwarf false indigo	AMNA	<i>Amorpha nana</i>	0–28	–
	Nuttall's sensitive-briar	MINU6	<i>Mimosa nuttallii</i>	0–14	–

Table 9. Community 1.2 plant community composition

Group	Common Name	Symbol	Scientific Name	Annual Production (Lb/Acre)	Foliar Cover (%)
Grass/Grasslike					
1	Little Bluestem			420–720	
	little bluestem	SCSC	<i>Schizachyrium scoparium</i>	420–720	–
2	Sideoats Grama			60–180	
	sideoats grama	BOCU	<i>Bouteloua curtipendula</i>	60–180	–
	sideoats grama	BOCU	<i>Bouteloua curtipendula</i>	60–180	–
3	Needlegrasses			12–60	
	needle and thread	HECOC8	<i>Hesperostipa comata</i> <i>ssp. comata</i>	12–60	–
	porcupinegrass	HESP11	<i>Hesperostipa spartea</i>	0–12	–
	green needlegrass	NAVI4	<i>Nassella viridula</i>	0–12	–
4	Short Warm Season Grasses			240–420	
	blue grama	BOGR2	<i>Bouteloua gracilis</i>	180–360	–
	hairy grama	BOHI2	<i>Bouteloua hirsuta</i>	0–120	–
	buffalograss	BODA2	<i>Bouteloua dactyloides</i>	0–120	–
5	Native Grasses			180–300	
	sedge	CAREX	<i>Carex</i>	120–180	–
	western wheatgrass	PASM	<i>Pascopyrum smithii</i>	24–120	–
	bluebunch wheatgrass	PSSP6	<i>Pseudoroegneria spicata</i>	0–100	–
	prairie sandreed	CALO	<i>Calamovilfa longifolia</i>	0–96	–

	Grass, perennial	ZGP	<i>Grass, perennial</i>	0–60	–
	big bluestem	ANGE	<i>Andropogon gerardii</i>	0–60	–
	prairie Junegrass	KOMA	<i>Koeleria macrantha</i>	12–60	–
	plains muhly	MUCU3	<i>Muhlenbergia cuspidata</i>	12–36	–
	Sandberg bluegrass	POSE	<i>Poa secunda</i>	0–36	–
	threeawn	ARIST	<i>Aristida</i>	0–36	–
Forb					
7	Forbs			60–120	
	sweetclover	MELIL	<i>Melilotus</i>	0–96	–
	white sagebrush	ARLU	<i>Artemisia ludoviciana</i>	24–72	–
	milkvetch	ASTRA	<i>Astragalus</i>	12–60	–
	false boneset	BREU	<i>Brickellia eupatorioides</i>	0–60	–
	Cuman ragweed	AMPS	<i>Ambrosia psilostachya</i>	12–60	–
	tarragon	ARDR4	<i>Artemisia dracunculus</i>	0–60	–
	prairie clover	DALEA	<i>Dalea</i>	12–60	–
	blacksamson echinacea	ECAN2	<i>Echinacea angustifolia</i>	12–60	–
	scarlet globemallow	SPCO	<i>Sphaeralcea coccinea</i>	12–60	–
	white heath aster	SYER	<i>Symphotrichum ericoides</i>	12–36	–
	yellow salsify	TRDU	<i>Tragopogon dubius</i>	0–36	–
	hairy false goldenaster	HEVI4	<i>Heterotheca villosa</i>	0–36	–
	dotted blazing star	LIPU	<i>Liatris punctata</i>	12–36	–
	scurfpea	PSORA2	<i>Psoralegium</i>	0–36	–
	goldenrod	SOLID	<i>Solidago</i>	0–36	–
	purple prairie clover	DAPU5	<i>Dalea purpurea</i>	0–36	–
	scarlet beeblossom	OESU3	<i>Oenothera suffrutescens</i>	12–36	–
	Forb, perennial	2FP	<i>Forb, perennial</i>	0–36	–
	pussytoes	ANTEN	<i>Antennaria</i>	0–24	–
	buttecandle	CRCE	<i>Cryptantha celosioides</i>	0–24	–
	curlycup gumweed	GRSQ	<i>Grindelia squarrosa</i>	0–24	–

	spiny phlox	PHHO	<i>Phlox hoodii</i>	0–24	–
	large Indian breadroot	PEES	<i>Pediomelum esculentum</i>	0–12	–
	beardtongue	PENST	<i>Penstemon</i>	0–12	–
Shrub/Vine					
8	Shrubs			60–120	
	prairie sagewort	ARFR4	<i>Artemisia frigida</i>	36–96	–
	rose	ROSA5	<i>Rosa</i>	0–60	–
	soapweed yucca	YUGL	<i>Yucca glauca</i>	0–60	–
	Subshrub (<.5m)	2SUBS	<i>Subshrub (<.5m)</i>	0–36	–
	leadplant	AMCA6	<i>Amorpha canescens</i>	0–24	–
	skunkbush sumac	RHTR	<i>Rhus trilobata</i>	0–24	–
	dwarf false indigo	AMNA	<i>Amorpha nana</i>	0–12	–

Table 10. Community 1.3 plant community composition

Group	Common Name	Symbol	Scientific Name	Annual Production (Lb/Acre)	Foliar Cover (%)
Grass/Grasslike					
1	Little Bluestem			40–80	
	little bluestem	SCSC	<i>Schizachyrium scoparium</i>	40–80	–
2	Sideoats Grama			8–40	
	sideoats grama	BOCU	<i>Bouteloua curtipendula</i>	8–40	–
3	Needlegrass			8–40	
	needle and thread	HECOC8	<i>Hesperostipa comata ssp. comata</i>	8–16	–
	porcupinegrass	HESP11	<i>Hesperostipa spartea</i>	0–8	–
	green needlegrass	NAVI4	<i>Nassella viridula</i>	0–8	–
4	Short Warm Season Grasses			200–320	
	blue grama	BOGR2	<i>Bouteloua gracilis</i>	160–320	–
	hairy grama	BOHI2	<i>Bouteloua hirsuta</i>	0–80	–
	buffalograss	BODA2	<i>Bouteloua dactyloides</i>	0–80	–
5	Native Grasses and Grass-likes			160–240	
	sedge	CAREX	<i>Carex</i>	120–200	–
	prairie Junegrass	KOMA	<i>Koeleria macrantha</i>	8–40	–

	plains muhly	MUCU3	<i>Muhlenbergia cuspidata</i>	16–40	–
	threeawn	ARIST	<i>Aristida</i>	0–40	–
	Grass, perennial	2GP	<i>Grass, perennial</i>	0–40	–
	prairie sandreed	CALO	<i>Calamovilfa longifolia</i>	0–16	–
	western wheatgrass	PASM	<i>Pascopyrum smithii</i>	8–16	–
	bluebunch wheatgrass	PSSP6	<i>Pseudoroegneria spicata</i>	0–10	–
	Sandberg bluegrass	POSE	<i>Poa secunda</i>	0–8	–
	big bluestem	ANGE	<i>Andropogon gerardii</i>	0	–
6	Non-native Grasses			0–40	
	cheatgrass	BRTE	<i>Bromus tectorum</i>	0–40	–
Forb					
7	Forbs			40–120	
	blacksamson echinacea	ECAN2	<i>Echinacea angustifolia</i>	16–80	–
	sweetclover	MELIL	<i>Melilotus</i>	0–80	–
	Cuman ragweed	AMPS	<i>Ambrosia psilostachya</i>	16–48	–
	pussytoes	ANTEN	<i>Antennaria</i>	0–40	–
	tarragon	ARDR4	<i>Artemisia dracunculus</i>	8–40	–
	white sagebrush	ARLU	<i>Artemisia ludoviciana</i>	16–40	–
	milkvetch	ASTRA	<i>Astragalus</i>	16–40	–
	scarlet beeblossom	OESU3	<i>Oenothera suffrutescens</i>	8–40	–
	curlycup gumweed	GRSQ	<i>Grindelia squarrosa</i>	0–40	–
	scarlet globemallow	SPCO	<i>Sphaeralcea coccinea</i>	8–40	–
	white heath aster	SYER	<i>Symphyotrichum ericoides</i>	16–40	–
	yellow salsify	TRDU	<i>Tragopogon dubius</i>	0–32	–
	Forb, perennial	2FP	<i>Forb, perennial</i>	0–24	–
	spiny phlox	PHHO	<i>Phlox hoodii</i>	8–24	–
	false boneset	BREU	<i>Brickellia eupatorioides</i>	0–24	–
	buttecandle	CRCE	<i>Cryptantha celosioides</i>	0–16	–
	prairie clover	DALEA	<i>Dalea</i>	8–16	–

	scurfpea	PSORA2	<i>Psoraleidium</i>	0–16	–
	goldenrod	SOLID	<i>Solidago</i>	0–16	–
	dotted blazing star	LIPU	<i>Liatris punctata</i>	8–16	–
	hairy false goldenaster	HEVI4	<i>Heterotheca villosa</i>	0–8	–
	purple prairie clover	DAPU5	<i>Dalea purpurea</i>	0–8	–
Shrub/Vine					
8	Shrubs			40–80	
	prairie sagewort	ARFR4	<i>Artemisia frigida</i>	40–80	–
	soapweed yucca	YUGL	<i>Yucca glauca</i>	0–64	–
	Subshrub (<.5m)	2SUBS	<i>Subshrub (<.5m)</i>	0–24	–
	leadplant	AMCA6	<i>Amorpha canescens</i>	0–16	–
	skunkbush sumac	RHTR	<i>Rhus trilobata</i>	0–16	–
	rose	ROSA5	<i>Rosa</i>	0–16	–
	dwarf false indigo	AMNA	<i>Amorpha nana</i>	0–8	–

Animal community

The following table lists annual suggested initial stocking rates with average growing conditions. These are conservative estimates that should be used only as guidelines in the initial stages of conservation planning. Often, the current plant composition does not entirely match any particular plant community (as described in this Ecological Site Description). Therefore, a resource inventory is necessary to document plant composition and production. More accurate carrying capacity estimates should eventually be calculated using the following stocking rate information along with animal preference data and actual stocking records, particularly when grazers other than cattle are involved. With consultation of the land manager, more intensive grazing management may result in improved harvest efficiencies and increased carrying capacity.

Plant Community = Little Bluestem-Needlegrass-Grama (1.1)

Average Annual Production (lbs./ac, air-dry) = 1400

Stocking Rate (AUM/ac) = 0.38

Plant Community = Little Bluestem-Grama (1.2)

Average Annual Production (lbs./ac, air-dry) = 1200

Stocking Rate (AUM/ac) = 0.33

Plant Community = Blue Grama/Sedge (1.3)

Average Annual Production (lbs./ac, air-dry) = 800

Stocking Rate (AUM/ac) = 0.22

*Based on 912 lbs./acre (air-dry weight) per Animal Unit Month (AUM), and on 25 percent harvest efficiency of preferred and desirable forage species (refer to USDA NRCS, National Range and Pasture Handbook).

Total annual production on-site may contain vegetation deemed undesirable or untargeted by the grazing animal. Therefore, AUM values may have been reduced to reflect only preferred or desirable forage species.

Grazing by domestic livestock is one of the major income-producing industries in the area. Rangeland in this area may provide yearlong forage. During the dormant period, the forage for livestock will likely be lacking protein to meet livestock requirements, and added protein will allow ruminants to better utilize the energy stored in grazed plant materials. A forage quality test (either directly or through fecal sampling) should be used to determine the level of supplementation needed.

Hydrological functions

Water is the principal factor limiting forage production on this site. This site is dominated by soils in hydrologic group B and C. Infiltration ranges from moderately slow to moderate. Runoff potential for this site varies from medium to very high depending on soil hydrologic group, slope, and ground cover. In many cases, areas with greater than 75 percent ground cover have the greatest potential for high infiltration and lower runoff. An example of an exception would be where short grasses form a strong sod and dominate the site. Normally areas where ground cover is less than 50 percent have the greatest potential to have reduced infiltration and higher runoff (refer to Section 4, NRCS National Engineering Handbook for runoff quantities and hydrologic curves).

Recreational uses

This site provides hunting opportunities for upland game species. The wide variety of plants which bloom from spring until fall have an aesthetic value that appeals to visitors.

Other products

Seed harvest of native plant species can provide additional income on this site.

Other information

Revision Notes: "Previously Approved" Provisional

This Provisional ecological site concept has passed Quality Control (QC) and Quality Assurance (QA) to ensure that the site meets the 2014 NESH standards for a Provisional ecological site. This is an updated "Previously Approved" ESD which represents a first-

generation tier of documentation that, prior to the release of the 2014 National Ecological Site Handbook (NESH), met all requirements as an “Approved” ESD as laid out in the 1997, rev.1, 2003 National Range and Pasture Handbook (NRPH). The document fully described the Reference State and Community Phase in the State-and-Transition model. All other alternative states are at least described in narrative form. The “Previously Approved” ESD has been field-tested for a minimum of five years and is a proven functional document for conservation planning. The “Previously Approved” ESD does not contain all tabular and narrative entries as required in the current “Approved” level of documentation but it is expected that the “Previously Approved” ESD will continue refinement towards an “Approved” status.

Site Development and Testing Plan:

Future work, as described in a Project Plan, is needed to validate the information in this Provisional Ecological Site Description. This will include field activities to collect low-, medium-, and high-intensity sampling, soil correlations, and analysis of that data. Annual field reviews should be done by soil scientists and vegetation specialists. The final field review, peer review, quality control, and quality assurance reviews of the ESD will be needed to produce the final document.

Non-discrimination Statement

In accordance with Federal civil rights law and U.S. Department of Agriculture (USDA) civil rights regulations and policies, the USDA, its Agencies, offices, and employees, and institutions participating in or administering USDA programs are prohibited from discriminating based on race, color, national origin, religion, sex, gender identity (including gender expression), sexual orientation, disability, age, marital status, family/parental status, income derived from a public assistance program, political beliefs, or reprisal or retaliation for prior civil rights activity, in any program or activity conducted or funded by USDA (not all bases apply to all programs). Remedies and complaint filing deadlines vary by program or incident.

Persons with disabilities who require alternative means of communication for program information (e.g., Braille, large print, audiotape, American Sign Language, etc.) should contact the responsible Agency or USDA's TARGET Center at (202) 720-2600 (voice and TTY) or contact USDA through the Federal Relay Service at (800) 877-8339. Additionally, program information may be made available in languages other than English.

To file a program discrimination complaint, complete the USDA Program Discrimination Complaint Form, AD-3027, available online and at any USDA office, or write a letter addressed to USDA and provide in the letter all of the information requested in the form. To request a copy of the complaint form, call (866) 632- 9992. Submit your completed form or letter to USDA by: (1) mail: U.S. Department of Agriculture, Office of the Assistant Secretary for Civil Rights, 1400 Independence Avenue, SW, Washington, D.C. 20250-9410; (2) fax: (202) 690-7442; or (3) email: program.intake@usda.gov.

Inventory data references

Information presented here has been derived from NRCS clipping data and other inventory data. Field observations from range-trained personnel were also used. Those involved in developing this site description include: Stan Boltz, Range Management Specialist, NRCS; Darrel DuVall, Range Management Specialist, NRCS; Jill Epley, Range Management Specialist, NRCS; Cheryl Nielsen, Range Management Specialist, NRCS; Rick Peterson, Range Management Specialist, NRCS; Mike Stirling, Range Management Specialist, NRCS. Data Source Number of Records Sample Period State County
SCS-RANGE-417 8 1985 – 1990 SD Custer, Pennington

Other references

EPA – Level III and Level IV Ecoregions of the Continental United States, (<https://www.epa.gov/eco-research/level-iii-and-iv-ecoregions-continental-united-states>). Available online. Accessed 01/03/17

High Plains Regional Climate Center, University of Nebraska, (<http://www.hprcc.unl.edu/>). Available online. Accessed 02/27/17.

USDA, NRCS. Soil Survey Staff. Official Soil Series Descriptions. Available online. Accessed 05/20/17.

USDA, NRCS. Soil Survey Staff. Web Soil Survey. Available online. Accessed 05/20/17.

USDA, NRCS. 2006. Land Resource Regions and Major Land Resource Areas of the United States, the Caribbean, and the Pacific Basin. Ag Handbook 296.

USDA, NRCS. 2014. National Ecological Site Handbook, 1st Ed.

USDA, NRCS. National Water and Climate Center. (<http://www.wcc.nrcs.usda.gov/>). Available online. Accessed 04/22/17.

USDA, NRCS. 1997, rev. 1, 2003. National Range and Pasture Handbook.

USDA, NRCS. National Soil Information System, Information Technology Center. (<http://nasis.nrcs.usda.gov>).

USDA, NRCS. 2017. The PLANTS Database (<http://plants.usda.gov>, 2017). Available online. Accessed 4/3/17.

USDA, NRCS. Various Published Soil Surveys.

Contributors

Stan Boltz

Acknowledgments

ESD updated by Rick L. Peterson, 5/1/17.

MLRA 60A Provisional Level Quality Control (QC) Process
9/28/17

Ecological Site from MLRA 60A were Previously Approved ESDs and meet the requirements as stated in the 2003 National Range and Pasture Handbook.

The Sites were updated to the Provisional Level by Rick L. Peterson, ESS, Rapid City, SSO in FY17.

The sites were reviewed by George Gamblin, RMS, Wheatland, WY and Mitch Faulkner, RMS, Belle Fourche, SD. Mitch Faulkner acted as the Provisional QC. The Sites were then reviewed and approved at the Provisional Level by David Kraft, Regional ESS, Salina, KS. Worked closely with Kent Cooley, Area SS, with MLRA key development and soils narratives

Rangeland health reference sheet

Interpreting Indicators of Rangeland Health is a qualitative assessment protocol used to determine ecosystem condition based on benchmark characteristics described in the Reference Sheet. A suite of 17 (or more) indicators are typically considered in an assessment. The ecological site(s) representative of an assessment location must be known prior to applying the protocol and must be verified based on soils and climate. Current plant community cannot be used to identify the ecological site.

Author(s)/participant(s)	Stan Boltz, Thad Berrett, Cheryl Nielsen
Contact for lead author	stanley.boltz@sd.usda.gov, 605-352-1236
Date	06/27/2008
Approved by	Suzanne Mayne-Kinney
Approval date	
Composition (Indicators 10 and 12) based on	Annual Production

Indicators

1. **Number and extent of rills:** Slight to none, typically on steeper slopes and discontinuous.

-
2. **Presence of water flow patterns:** None, or barely visible and discontinuous with numerous debris dams when present.

 3. **Number and height of erosional pedestals or terracettes:** Few pedestalled plants typically on steeper slopes.

 4. **Bare ground from Ecological Site Description or other studies (rock, litter, lichen, moss, plant canopy are not bare ground):** 0 to 15 percent is typical.

 5. **Number of gullies and erosion associated with gullies:** None should be present.

 6. **Extent of wind scoured, blowouts and/or depositional areas:** None.

 7. **Amount of litter movement (describe size and distance expected to travel):** Small size litter classes will generally move short distances, some medium size class litter will move very short distances. Litter debris dams are occasionally present.

 8. **Soil surface (top few mm) resistance to erosion (stability values are averages - most sites will show a range of values):** Soil aggregate stability ratings should typically be 5 to 6, normally 6. Surface organic matter adheres to the soil surface. Soil surface fragments will typically retain structure indefinitely when dipped in distilled water.

 9. **Soil surface structure and SOM content (include type of structure and A-horizon color and thickness):** A-horizon should be 2 to 6 inches thick with light to dark brownish gray colors. Structure should typically be fine granular at least in the upper A-horizon. Some soils have subangular blocky structure parting to weak fine granular.

 10. **Effect of community phase composition (relative proportion of different functional**

groups) and spatial distribution on infiltration and runoff: Combination of shallow and deep rooted species (mid & tall rhizomatous and tufted perennial cool- and warm-season grasses) with fine and coarse roots positively influences infiltration.

11. **Presence and thickness of compaction layer (usually none; describe soil profile features which may be mistaken for compaction on this site):** None – when dry, subsoil can be hard and appear to be compacted, but no platy structure will be present.
-

12. **Functional/Structural Groups (list in order of descending dominance by above-ground annual-production or live foliar cover using symbols: >>, >, = to indicate much greater than, greater than, and equal to):**

Dominant: Mid/tall warm-season bunchgrasses >

Sub-dominant: Short/mid warm-season rhizomatous > cool-season bunchgrass = cool-season rhizomatous > forbs >

Other: Shrubs

Additional:

13. **Amount of plant mortality and decadence (include which functional groups are expected to show mortality or decadence):** Very little evidence of decadence or mortality. Bunch grasses have strong, healthy centers and shrubs are vigorous.
-

14. **Average percent litter cover (%) and depth (in):**
-

15. **Expected annual annual-production (this is TOTAL above-ground annual-production, not just forage annual-production):** Production ranges from 1,000-1,900 lbs./acre (air-dry weight). Reference value production is 1,400 lbs./acre (air-dry weight).
-

16. **Potential invasive (including noxious) species (native and non-native). List species which BOTH characterize degraded states and have the potential to become a**

dominant or co-dominant species on the ecological site if their future establishment and growth is not actively controlled by management interventions. Species that become dominant for only one to several years (e.g., short-term response to drought or wildfire) are not invasive plants. Note that unlike other indicators, we are describing what is NOT expected in the reference state for the ecological site: State and local noxious weeds

17. **Perennial plant reproductive capability:** All species exhibit high vigor relative to climatic conditions. Do not rate based solely on seed production. Perennial grasses should have vigorous rhizomes or tillers.
-