

Ecological site R060AY013SD Claypan

Last updated: 6/25/2024
Accessed: 06/30/2024

General information

Provisional. A provisional ecological site description has undergone quality control and quality assurance review. It contains a working state and transition model and enough information to identify the ecological site.

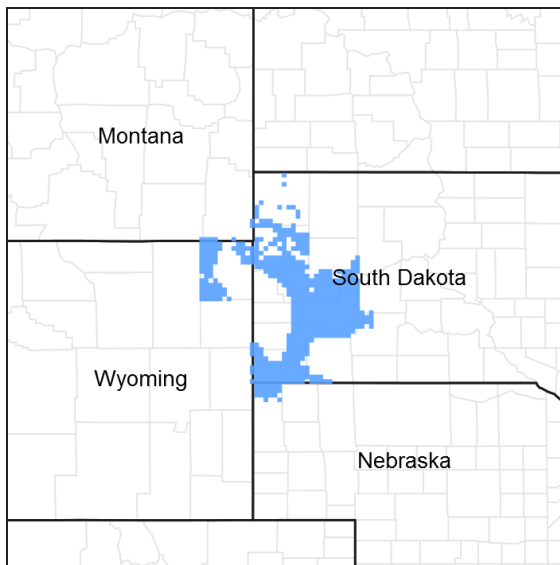

Figure 1. Mapped extent

Areas shown in blue indicate the maximum mapped extent of this ecological site. Other ecological sites likely occur within the highlighted areas. It is also possible for this ecological site to occur outside of highlighted areas if detailed soil survey has not been completed or recently updated.

MLRA notes

Major Land Resource Area (MLRA): 060A–Pierre Shale Plains

The Pierre Shale Plains (MLRA 60A) consists of approximately 10,150 square miles, the majority of which is in South Dakota (70 percent) and small portions are in Montana (2 percent), Nebraska (8 percent), and Wyoming (20 percent). It encircles the Black Hills (MLRA 62) and the Dakota Hogback (MLRA 61). MLRA 60A includes portions of the Oglala, Buffalo Gap, and Thunder Basin National Grasslands. It also includes small sections of the Pine Ridge Indian Reservation, Badlands National Park, and Black Hills National Forest. The Cheyenne and Belle Fourche Rivers flow through the MLRA.

MLRA 60A is in the unglaciated section of the Missouri Plateau, of the Great Plains Province of the Interior Plains. It is an area of old plateaus and terraces that have been deeply eroded. Cretaceous Pierre Shale underlies almost all of this MLRA. This is a marine sediment with layers of volcanic ash that has been altered to smectitic clay. These clays shrink as they dry and swell as they receive moisture. Soils are shallow to very deep and generally are well drained and clayey.

Elevations generally range from 2,620 to 3,610 feet throughout the MLRA, but can range up to 4,260 feet. The average annual precipitation for the western side of the MLRA is 13 to 16 inches, whereas the eastern side receives 16 to 18 inches. A suite of ecological sites has been written specifically for these two precipitation zones. The Locator Map shows the break between the two precipitation zones.

This area supports a mixed natural prairie vegetation consisting of both cool- and warm-season grasses and forbs. Wyoming big sagebrush occurs primarily in the drier western portion of the MLRA, however, small remnant stands can be found in the eastern portion. Dominant land uses of the area are primarily ranching and, to a lesser extent, farming. Major resource concerns to this MLRA are wind erosion and surface water quality.

Classification relationships

USDA - Land Resource Region G – Western Great Plains Range and Irrigated Region, Major Land Resource Area (MLRA) 60A – Pierre Shale Plains.

EPA - Level IV Ecoregions of the Continental United States: 43e – Sagebrush Steppe, 43g Semiarid Pierre Shale Plains, and 43k – Dense Clay Prairie.

Ecological site concept

The Claypan sites occurs throughout the MLRA. It is located on gently undulating to rolling sedimentary uplands with slopes ranging from 0 to 9 percent. Soil are formed from soft siltstone, shales, and alluvium. The soil surface texture is loam to silt loam, 5 to 15 inches thick, subsurface textures are silt loam to clay. The Btn horizon creates a claypan of extremely hard sodium affected clay (natric), which occurs between 5 and 16 inches of the surface. This root-restricting layer has round-topped or “biscuit-shaped” columnar structure.

Vegetation in the Reference State (1.0) consists primarily of cool-season rhizomatous wheatgrasses and needlegrasses and warm-season shortgrasses. Prickly pear cactus is typically present in the plant community but in minor amounts. Wyoming big sagebrush can occur on this site, primarily in the western portion of the MLRA.

Associated sites

R060AY007SD	Saline Lowland
R060AY011SD	Clayey 13-16" P.Z.
R060AY015SD	Thin Claypan
R060AY018SD	Dense Clay
R060AY040SD	Clayey 16-18" P.Z.

Similar sites

R060AY011SD	Clayey 13-16" P.Z. More green needlegrass; higher production
R060AY015SD	Thin Claypan Lower production; greater dominance of shortgrass and salt-tolerant species
R060AY040SD	Clayey 16-18" P.Z. More green needlegrass; higher production

Table 1. Dominant plant species

Tree	Not specified
Shrub	Not specified
Herbaceous	(1) <i>Pascopyrum smithii</i> (2) <i>Elymus lanceolatus</i>

Physiographic features

This site occurs on nearly level or gently sloping uplands.

Table 2. Representative physiographic features

Landforms	(1) Flat (2) Plain (3) Terrace
Flooding frequency	None
Elevation	2,500–4,300 ft
Slope	0–9%
Water table depth	48–80 in
Aspect	Aspect is not a significant factor

Climatic features

The climate in this MLRA is typical of the drier portions of the Northern Great Plains, where sagebrush steppes to the west yield to grassland steppes to the east. Annual precipitation, for the entire MLRA, ranges from 13 to 18 inches per year, with most occurring during the growing season. Temperatures show a wide range between summer and winter and between daily maximums and minimums, due to the high elevation and dry air, which permits rapid incoming and outgoing radiation. Cold air masses from Canada in winter move rapidly from northwest to southeast and account for extreme minimum temperatures. Chinook winds may occur in winter and bring rapid rises in temperature. Extreme storms may occur during the winter, but the more severe occur during late fall, late winter, and spring.

The normal average annual temperature is about 46°F. January is the coldest month with average temperatures ranging from about 19°F (Moorcroft CAA, WY) to about 22°F (Belle Fourche, SD). July is the warmest month with temperatures averaging from about 70°F (Moorcroft CAA, WY) to about 72°F (Belle Fourche, SD). The range of normal average monthly temperatures between the coldest and warmest months is about 51°F. Hourly winds are estimated to average about 11 miles per hour annually, ranging from about 13 miles per hour during the spring to about 10 miles per hour during the summer. Daytime winds generally are stronger than nighttime, and occasional strong storms may bring brief periods of high winds with gusts to more than 50 miles per hour.

Growth of cool-season plants begins in early to mid-March, slowing or ceasing in late June. Warm-season plants begin growth about mid-May and can continue to early or mid-September. Green-up of cool-season plants may occur in September and October when adequate soil moisture is present.

Table 3. Representative climatic features

Frost-free period (characteristic range)	98-105 days
Freeze-free period (characteristic range)	123-129 days
Precipitation total (characteristic range)	15-18 in
Frost-free period (actual range)	76-108 days
Freeze-free period (actual range)	113-133 days
Precipitation total (actual range)	14-18 in
Frost-free period (average)	97 days
Freeze-free period (average)	124 days
Precipitation total (average)	16 in

Climate stations used

- (1) BELLE FOURCHE [USC00390559], Belle Fourche, SD
- (2) UPTON [USC00489205], Upton, WY
- (3) ARDMORE 1 NW [USC00390236], Edgemont, SD
- (4) WASTA [USC00398911], Owanka, SD

- (5) REDBIRD [USC00487555], Lance Creek, WY
- (6) MOORCROFT 3S [USW00024088], Moorcroft, WY

Influencing water features

No significant water features influence this site.

Wetland description

Not Applicable.

Soil features

The loam to silt loam surface textures of this site change abruptly at about 5 to 15 inches below the surface, to an extremely hard clayey Btn horizon having round-topped or “bun shaped” columnar or prismatic structure. These subsoils are high in sodium. Saturated hydraulic conductivity is very slow, available water capacity is low, and permeability is slow to very slow. Slopes range from 0 to 9 percent. The soils on this site are deep, somewhat poorly to well drained, and were formed in residuum from siltstone, shale, or silty and clayey alluvium. The surface layer is 5 to 15 inches thick. The texture of the subsoil ranges from loam to clay. The soils have a slow to very slow infiltration rate. This site should show slight to no evidence of rills or wind-scoured areas. Water flow paths are broken, irregular in appearance, or discontinuous with numerous debris dams or vegetative barriers.

Soils correlated to the Claypan ecological site: Absted, Archin, Beckton, Wortman

These soils are mainly susceptible to water erosion. More information can be found in the various soil survey reports. Contact the local USDA Service Center for soil survey reports that include more detail specific to your location.

Table 4. Representative soil features

Surface texture	(1) Silt loam (2) Loam (3) Fine sandy loam
Family particle size	(1) Clayey
Drainage class	Moderately well drained to well drained
Permeability class	Slow to very slow
Soil depth	20–60 in
Surface fragment cover ≤3"	0%
Surface fragment cover >3"	0%
Available water capacity (0-40in)	4–5 in
Calcium carbonate equivalent (0-40in)	0–25%
Electrical conductivity (0-40in)	0–16 mmhos/cm
Sodium adsorption ratio (0-40in)	13–50
Soil reaction (1:1 water) (0-40in)	5.6–9.6
Subsurface fragment volume ≤3" (Depth not specified)	5%
Subsurface fragment volume >3" (Depth not specified)	0%

Ecological dynamics

This site developed under Northern Great Plains climatic conditions, natural influences of large herbivores, occasional fire, and other biotic and abiotic factors that typically influence soil/site development. Changes will occur in the plant communities due to short-term weather variations, impacts of native and/or exotic plant and animal species, and management actions. While the following plant community descriptions describe more typical transitions between communities that will occur, severe disturbances, such as periods of well-below average precipitation, can cause significant shifts in plant communities and/or species composition.

The plant community upon which interpretations are primarily based is the Reference Plant Community (1.1). The Reference Plant Community has been determined by studying rangeland relic areas, areas protected from excessive disturbance, and areas under long-term rotational grazing regimes. Trends in plant community dynamics ranging from heavily grazed to lightly grazed areas, seasonal use pastures, and historical accounts also have been used. Plant communities, states, transitional pathways, and thresholds have been determined through similar studies and experience.

The following diagram illustrates the common States and Plant Communities Phases (PCP) commonly occurring on the site and the transition pathways between communities and states. The ecological processes are discussed in more detail in the plant community descriptions following the diagram.

State and transition model

Claypan – R060AY013SD 4/12/17

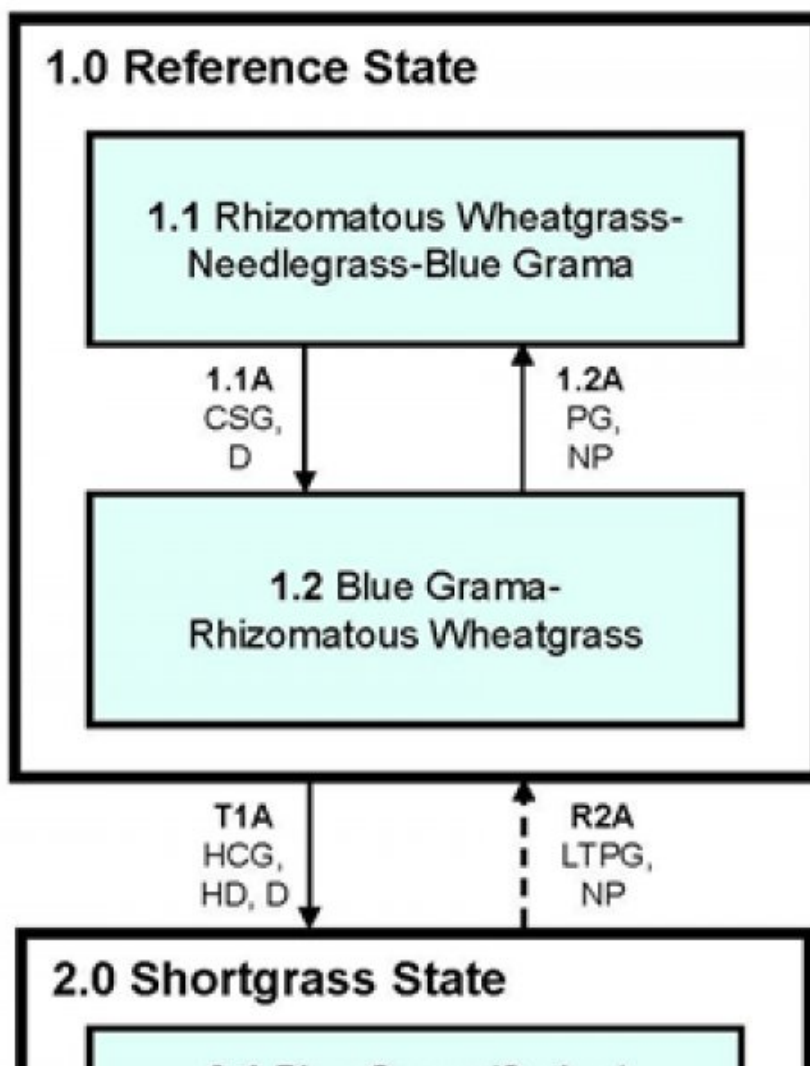

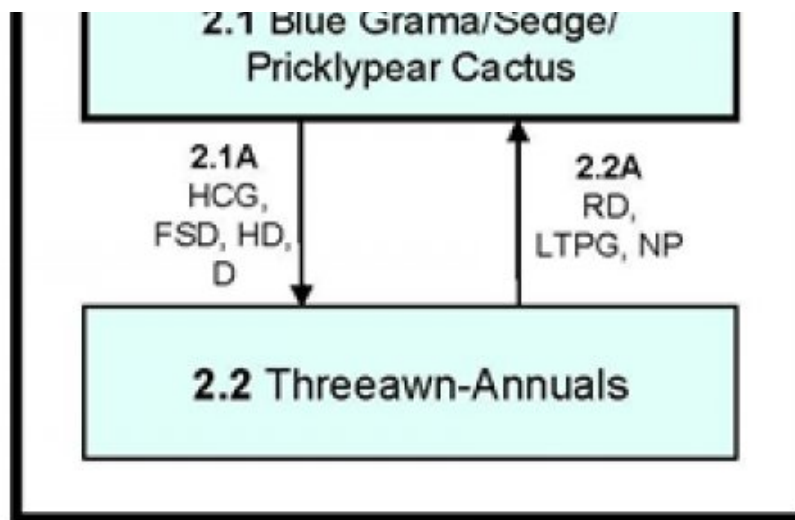

CSG – Continuous seasonal grazing without adequate recovery periods
 D – Drought
 FSD – Frequent and severe defoliation
 HCG – Heavy continuous grazing
 HD – Heavy disturbance
 HSG – Heavy seasonal grazing
 LTPG – Long-term prescribed grazing, including adequate recovery opportunity and change in season of use
 NP – Normal precipitation
 PG – Prescribed grazing with adequate recovery opportunity
 ———> Transition may not be fast and/or feasible

Figure 8. Claypan - R060AY013SD

Diagram Legend - Claypan - R060AY013SD		
T1A		Heavy continuous grazing, without adequate recovery, heavy disturbance or drought.
R2A		Long-term prescribed grazing with change in season of use and adequate recovery, normal precipitation following drought. Recovery may not be fast and/or feasible.
CP 1.1A	1.1 - 1.2	Continuous seasonal grazing without adequate recovery, drought.
CP 1.2A	1.2 - 1.1	Prescribed grazing including change in season of use, proper stocking and adequate time for rest and recovery, normal precipitation following drought.
CP 2.1A	2.1 - 2.2	Heavy continuous grazing, frequent and severe defoliation, heavy disturbance, drought.
CP 2.2A	2.2 - 2.1	Removal of disturbance, long-term prescribed grazing including change in season of use, proper stocking and adequate time for rest and recovery, normal precipitation following drought.

Figure 9. Claypan - R060AY013SD

State 1 Reference State

This state represents what is believed to show the natural range of variability that dominated the dynamics in this ecological site prior to European settlement. This site, in Reference, is dominated by a mix of cool-season rhizomatous wheatgrasses and needlegrasses and warm-season shortgrasses. Heavy grazing will cause the plant

community to transition to a community dominated by warm-season shortgrasses and cool-season rhizomatous wheatgrasses. Erosion of the surface horizon is a potential outcome with heavy grazing. In pre-European times the primary disturbances included grazing by large ungulates and small mammals, and drought. Favorable growing conditions occurred during the spring and warm months of June through August. Today a similar state can be found in areas where proper livestock use has occurred.

Community 1.1 Rhizomatous Wheatgrass-Needlegrass-Blue Grama



Figure 10. Plant Community Phase 1.1

The plant community upon which interpretations are primarily based is the Rhizomatous Wheatgrass-Needlegrass-Blue Grama Plant Community (1.1). This is also considered to be the Reference Plant Community. This plant community can be found on areas that are properly managed with prescribed grazing that allows for proper utilization, changes in season of use, and adequate recovery periods following each grazing event. The potential vegetation is about 85 to 95 percent grasses or grass-like plants, 5 to 10 percent forbs, and 1 to 5 percent shrubs. Cool-season grasses dominate the site, but warm-season shortgrasses are also prevalent. Western wheatgrass is the dominant grass. Other grasses and grass-like plants occurring include needle and thread, green needlegrass, blue grama, prairie Junegrass, and threadleaf sedge. Significant forbs include silverleaf scurfpea, biscuitroot, wild parsley, cudweed sagewort, and heath aster. Silver and/or big sagebrush are the principal shrubs. Other shrubs include fringed sagewort, rubber rabbitbrush, and cactus. This plant community phase (PCP) is well adapted to the Northern Great Plains climatic conditions. Individual species can vary greatly in production depending on growing conditions (timing and amount of precipitation and temperature). Community dynamics, nutrient cycle, water cycle, and energy flow are functioning properly. Plant litter is properly distributed with very little movement off-site, and natural plant mortality is low. The diversity in plant species allows for high drought tolerance. Good vegetative cover coupled with moderate available water-holding capacity can provide a favorable soil-water-plant relationship.

Table 5. Annual production by plant type

Plant Type	Low (Lb/Acre)	Representative Value (Lb/Acre)	High (Lb/Acre)
Grass/Grasslike	825	1246	1765
Forb	65	105	145
Shrub/Vine	10	42	75
Moss	0	7	15
Total	900	1400	2000

Figure 12. Plant community growth curve (percent production by month).
SD6002, Pierre Shale Plains, cool-season dominant, warm-season sub-dominant.. Cool-season dominant, warm-season sub-dominant..

Jan	Feb	Mar	Apr	May	Jun	Jul	Aug	Sep	Oct	Nov	Dec
0	0	3	10	23	34	15	6	5	4	0	0

Community 1.2

Blue Grama- Rhizomatous Wheatgrass

This plant community develops under continuous seasonal grazing (i.e., grazing an area during the same season every year) or from over-utilization during extended drought periods. The potential vegetation is about 75 to 90 percent grasses or grass-like plants, 5 to 10 percent forbs, and 5 to 15 percent shrubs. A fairly even mix of cool-season grasses and short warm-season grasses dominate this plant community. Blue grama and western wheatgrass are the dominant grasses. Other grasses and grass-like plants occurring include needle and thread, buffalograss, prairie Junegrass, threadleaf sedge, dropseed, Sandberg bluegrass, and inland saltgrass. Significant forbs include silverleaf scurfpea, cudweed sagewort, western yarrow, and heath aster. Silver and/or big sagebrush are the principal shrubs, and increase slightly when compared to the Reference Plant Community (1.1). Other shrubs include fringed sagewort, rubber rabbitbrush, broom snakeweed, and cactus. This plant community is somewhat resistant to change. The dominant herbaceous species are very adapted to grazing; however, the mid-grass species and the more palatable forbs will decrease in the community through continuous seasonal grazing. If the herbaceous component is intact, it tends to be resilient if disturbance is not long-term. Because of the sod-forming habit of the shortgrass species, water infiltration decreases and runoff increases when compared to the Reference Plant Community.

Table 6. Annual production by plant type

Plant Type	Low (Lb/Acre)	Representative Value (Lb/Acre)	High (Lb/Acre)
Grass/Grasslike	510	825	1340
Shrub/Vine	45	100	155
Forb	45	75	105
Total	600	1000	1600

Figure 14. Plant community growth curve (percent production by month). SD6002, Pierre Shale Plains, cool-season dominant, warm-season sub-dominant.. Cool-season dominant, warm-season sub-dominant..

Jan	Feb	Mar	Apr	May	Jun	Jul	Aug	Sep	Oct	Nov	Dec
0	0	3	10	23	34	15	6	5	4	0	0

Pathway 1.1A

Community 1.1 to 1.2

Continuous seasonal grazing (annual, early spring) and drought will convert the PCP to the Blue Grama-Rhizomatous Wheatgrass Plant Community.

Pathway 1.2A

Community 1.2 to 1.1

Prescribed grazing with proper stocking, change in season of use, adequate time for recovery, and a return to normal precipitation patterns will shift this PCP back to the Rhizomatous Wheatgrass-Blue Grama Plant Community (1.1).

State 2

Shortgrass State

This state is dominated by shortgrass species, upland sedges, and pricklypear cactus. It is the result of grazing practices that remove the mid-stature cool- and warm-season grasses, and provide a competitive advantage to shortgrasses and grass-like species that are grazing-resistant. Water infiltration has decreased and runoff has increased in this state. This state is very resilient and resistant to change.

Community 2.1

Blue Grama/Sedge/Pricklypear Cactus

This plant community results from heavy, continuous grazing and/or annual, early spring seasonal grazing. Shortgrasses and forbs increase to dominate the plant community and annual production decreases dramatically. Lack of litter and short plant heights result in high soil temperatures, high soil water loss, and poor water infiltration rates, which gives blue grama a competitive advantage over cool-season mid- grasses. Blue grama and sedge are the prominent species with the balance being lesser amounts of buffalograss, inland saltgrass, prairie Junegrass, western wheatgrass, and needle and thread. Forbs and shrubs such as fringed sagewort, cudweed sagewort, heath aster, broom snakeweed, cactus, and western yarrow may also be present. This plant community is relatively stable. The thick sod and competitive advantage prevents other species from establishing. This plant community is less productive than the Reference State (1.0). Soil erosion will be minimal due to the sod-forming habit of blue grama and buffalograss.

Table 7. Annual production by plant type

Plant Type	Low (Lb/Acre)	Representative Value (Lb/Acre)	High (Lb/Acre)
Grass/Grasslike	340	536	830
Shrub/Vine	30	65	100
Forb	30	49	70
Total	400	650	1000

Figure 16. Plant community growth curve (percent production by month). SD6003, Pierre Shale Plains, cool-season/warm-season co-dominant.. Cool-season, warm-season co-dominant.

Jan	Feb	Mar	Apr	May	Jun	Jul	Aug	Sep	Oct	Nov	Dec
0	0	3	10	20	28	21	10	5	3	0	0

Community 2.2 Threawn-Annuals

This plant community is dominated by threawn, perennial forbs (some of which are invasive), and annual grasses and forbs. Total annual production has decreased significantly, resulting in reduced litter, increased bare ground, poor water infiltration, higher soil temperature, and higher evaporation rates. Soil loss through erosion may expose salts and increase inland saltgrass and other salt-tolerant species.

Table 8. Annual production by plant type

Plant Type	Low (Lb/Acre)	Representative Value (Lb/Acre)	High (Lb/Acre)
Grass/Grasslike	115	303	606
Forb	24	80	147
Tree	11	67	147
Total	150	450	900

Figure 18. Plant community growth curve (percent production by month). SD6004, Pierre Shale Plains, warm-season dominant, cool-season sub-dominant. Warm season dominant, cool-season sub-dominant.

Jan	Feb	Mar	Apr	May	Jun	Jul	Aug	Sep	Oct	Nov	Dec
0	0	3	7	18	25	25	15	7	0	0	0

Pathway 2.1A Community 2.1 to 2.2

Heavy, continuous grazing, or frequent and severe defoliation due to such occurrences as prairie dog activity, confined feeding areas, and heavy use areas will shift this plant community to the Threawn-Annuals plant community (2.2). Drought can expedite this plant community shift.

Pathway 2.2A Community 2.2 to 2.1

This plant community can transition back to the Blue Grama/Sedge/Pricklypear Cactus plant community (2.1) by removing disturbances and applying long-term prescribed grazing, including proper stocking, change in season of use, and adequate time for rest and recovery in conjunction with a return to normal precipitation patterns.

Transition 1A State 1 to 2

Heavy, continuous grazing, without adequate recovery, heavy disturbance, or drought will convert this plant community to the Shortgrass State (2.0).

Restoration pathway 2A State 2 to 1

Under long-term prescribed grazing, including proper stocking, change in season of use, and adequate rest periods in combination with a return to normal precipitation patterns this plant community may return to the Reference State (1.0). This may take a long period of time and may not meet management goals.

Additional community tables

Table 9. Community 1.1 plant community composition

Group	Common Name	Symbol	Scientific Name	Annual Production (Lb/Acre)	Foliar Cover (%)
Grass/Grasslike					
1	Rhizomatous Wheatgrasses			280–560	
	western wheatgrass	PASM	<i>Pascopyrum smithii</i>	280–560	–
	Montana wheatgrass	ELAL7	<i>Elymus albicans</i>	0–210	–
	thickspike wheatgrass	ELLAL	<i>Elymus lanceolatus</i> ssp. <i>lanceolatus</i>	70–210	–
2	Needlegrasses			70–280	
	needle and thread	HECOC8	<i>Hesperostipa comata</i> ssp. <i>comata</i>	70–210	–
	green needlegrass	NAVI4	<i>Nassella viridula</i>	70–210	–
3	Short Warm Season Grasses			70–280	
	blue grama	BOGR2	<i>Bouteloua gracilis</i>	70–280	–
	buffalograss	BODA2	<i>Bouteloua dactyloides</i>	0–70	–
4	Grass-likes			28–140	
	threadleaf sedge	CAFI	<i>Carex filifolia</i>	28–140	–
	Grass-like (not a true grass)	2GL	<i>Grass-like (not a true grass)</i>	0–70	–
5	Other Native Grasses			28–140	
	Grass, perennial	2GP	<i>Grass, perennial</i>	0–70	–
	sideoats grama	BOCU	<i>Bouteloua curtipendula</i>	0–70	–
	prairie sandreed	CALO	<i>Calamovilfa longifolia</i>	0–56	–
	little bluestem	SCSC	<i>Schizachyrium scoparium</i>	0–56	–
	dropseed	SPORO	<i>Sporobolus</i>	14–42	–
	saltgrass	DISP	<i>Distichlis spicata</i>	0–42	–
	prairie Junegrass	KOMA	<i>Koeleria macrantha</i>	14–42	–
	Sandberg bluegrass	POSE	<i>Poa secunda</i>	0–28	–

Forb					
7	Forbs			70–140	
	Forb, perennial	2FP	<i>Forb, perennial</i>	0–28	–
	common yarrow	ACMI2	<i>Achillea millefolium</i>	14–28	–
	onion	ALLIU	<i>Allium</i>	14–28	–
	white sagebrush	ARLU	<i>Artemisia ludoviciana</i>	14–28	–
	desertparsley	LOMAT	<i>Lomatium</i>	14–28	–
	leafy wildparsley	MUDI	<i>Musineon divaricatum</i>	14–28	–
	scurfpea	PSORA2	<i>Psoralea</i>	14–28	–
	upright prairie coneflower	RACO3	<i>Ratibida columnifera</i>	14–28	–
	scarlet globemallow	SPCO	<i>Sphaeralcea coccinea</i>	14–28	–
	American vetch	VIAM	<i>Vicia americana</i>	14–28	–
	deathcamas	ZIGAD	<i>Zigadenus</i>	0–14	–
	white heath aster	SYER	<i>Symphyotrichum ericoides</i>	0–14	–
	Missouri goldenrod	SOMI2	<i>Solidago missouriensis</i>	0–14	–
	scarlet beeblossom	OESU3	<i>Oenothera suffrutescens</i>	0–14	–
	woolly plantain	PLPA2	<i>Plantago patagonica</i>	0–14	–
	rush skeletonplant	LYJU	<i>Lygodesmia juncea</i>	0–14	–
	wavyleaf thistle	CIUN	<i>Cirsium undulatum</i>	0–14	–
	rosy pussytoes	ANRO2	<i>Antennaria rosea</i>	0–14	–
	Forb, annual	2FA	<i>Forb, annual</i>	0–14	–
Shrub/Vine					
8	Shrubs			14–70	
	silver sagebrush	ARCA13	<i>Artemisia cana</i>	0–70	–
	big sagebrush	ARTR2	<i>Artemisia tridentata</i>	0–70	–
	prairie sagewort	ARFR4	<i>Artemisia frigida</i>	14–42	–
	Subshrub (<.5m)	2SUBS	<i>Subshrub (<.5m)</i>	0–42	–
	rubber rabbitbrush	ERNA10	<i>Ericameria nauseosa</i>	0–28	–
	plains pricklypear	OPPO	<i>Opuntia polyacantha</i>	14–28	–
	broom snakeweed	GUSA2	<i>Gutierrezia sarothrae</i>	0–14	–
	brittle pricklypear	OPFR	<i>Opuntia fragilis</i>	0–14	–
Moss					
9	Cryptogams			0–14	
	lesser spikemoss	SEDE2	<i>Selaginella densa</i>	0–14	–
	lesser spikemoss	SEDE2	<i>Selaginella densa</i>	0–14	–

Table 10. Community 1.2 plant community composition

Group	Common Name	Symbol	Scientific Name	Annual Production (Lb/Acre)	Foliar Cover (%)
Grass/Grasslike					
1	Rhizomatous Wheatgrasses			150–300	
	western wheatgrass	PASM	<i>Pascopyrum smithii</i>	150–250	–
	Montana wheatgrass	ELAL7	<i>Elymus albicans</i>	0–150	–
	thickspike wheatgrass	ELLAL	<i>Elymus lanceolatus</i> ssp. <i>lanceolatus</i>	0–150	–

			laricoidatus		
2	Needlegrass			50–100	
	needle and thread	HECOC8	<i>Hesperostipa comata ssp. comata</i>	50–100	–
	green needlegrass	NAVI4	<i>Nassella viridula</i>	0–50	–
3	Short Warm Season Grasses			150–350	
	blue grama	BOGR2	<i>Bouteloua gracilis</i>	150–300	–
	buffalograss	BODA2	<i>Bouteloua dactyloides</i>	50–100	–
4	Grass-likes			100–200	
	threadleaf sedge	CAFI	<i>Carex filifolia</i>	100–200	–
	Grass-like (not a true grass)	2GL	<i>Grass-like (not a true grass)</i>	0–50	–
5	Other Native Grasses			50–200	
	saltgrass	DISP	<i>Distichlis spicata</i>	50–100	–
	prairie Junegrass	KOMA	<i>Koeleria macrantha</i>	30–70	–
	Sandberg bluegrass	POSE	<i>Poa secunda</i>	0–50	–
	Grass, perennial	2GP	<i>Grass, perennial</i>	0–50	–
	threeawn	ARIST	<i>Aristida</i>	0–50	–
	dropseed	SPORO	<i>Sporobolus</i>	0–50	–
	prairie sandreed	CALO	<i>Calamovilfa longifolia</i>	0–50	–
	sideoats grama	BOCU	<i>Bouteloua curtipendula</i>	0–30	–
	little bluestem	SCSC	<i>Schizachyrium scoparium</i>	0–30	–
6	Non-native Grasses			0–50	
	cheatgrass	BRTE	<i>Bromus tectorum</i>	0–50	–
	Kentucky bluegrass	POPR	<i>Poa pratensis</i>	0–50	–
Forb					
7	Forbs			50–100	
	common yarrow	ACMI2	<i>Achillea millefolium</i>	20–50	–
	white sagebrush	ARLU	<i>Artemisia ludoviciana</i>	20–50	–
	scarlet globemallow	SPCO	<i>Sphaeralcea coccinea</i>	10–30	–
	white heath aster	SYER	<i>Symphotrichum ericoides</i>	10–30	–
	scurfpea	PSORA2	<i>Psoralegium</i>	10–30	–
	upright prairie coneflower	RACO3	<i>Ratibida columnifera</i>	10–20	–
	American vetch	VIAM	<i>Vicia americana</i>	10–20	–
	woolly plantain	PLPA2	<i>Plantago patagonica</i>	0–20	–
	desertparsley	LOMAT	<i>Lomatium</i>	10–20	–
	onion	ALLIU	<i>Allium</i>	10–20	–
	Forb, perennial	2FP	<i>Forb, perennial</i>	0–20	–
	leafy wildparsley	MUDI	<i>Musineon divaricatum</i>	10–20	–
	Forb, annual	2FA	<i>Forb, annual</i>	0–10	–
	rosy pussytoes	ANRO2	<i>Antennaria rosea</i>	0–10	–
	rush skeletonplant	LYJU	<i>Lygodesmia juncea</i>	0–10	–
	wavyleaf thistle	CIUN	<i>Cirsium undulatum</i>	0–10	–
	scarlet beeblossom	OESU3	<i>Oenothera suffrutescens</i>	0–10	–
	deathcamas	ZIGAD	<i>Zigadenus</i>	0–10	–
	Missouri goldenrod	SOMI2	<i>Solidago missouriensis</i>	0–10	–

	Missouri goldenrod	OPVIZ	<i>Solidago missouriensis</i>	5-10	-
Shrub/Vine					
8	Shrubs/Vine			50-150	
	plains pricklypear	OPPO	<i>Opuntia polyacantha</i>	20-100	-
	rubber rabbitbrush	ERNA10	<i>Ericameria nauseosa</i>	0-100	-
	silver sagebrush	ARCA13	<i>Artemisia cana</i>	0-70	-
	big sagebrush	ARTR2	<i>Artemisia tridentata</i>	0-70	-
	prairie sagewort	ARFR4	<i>Artemisia frigida</i>	20-50	-
	broom snakeweed	GUSA2	<i>Gutierrezia sarothrae</i>	10-50	-
	brittle pricklypear	OPFR	<i>Opuntia fragilis</i>	0-30	-
	Subshrub (<.5m)	2SUBS	<i>Subshrub (<.5m)</i>	0-30	-
Moss					
9	Cryptogams			0-30	
	lesser spikemoss	SEDE2	<i>Selaginella densa</i>	0-30	-
	lesser spikemoss	SEDE2	<i>Selaginella densa</i>	0-14	-

Table 11. Community 2.1 plant community composition

Group	Common Name	Symbol	Scientific Name	Annual Production (Lb/Acre)	Foliar Cover (%)
Grass/Grasslike					
1	Rhizomatous Wheatgrasses			33-98	
	western wheatgrass	PASM	<i>Pascopyrum smithii</i>	33-98	-
	Montana wheatgrass	ELAL7	<i>Elymus albicans</i>	0-65	-
	thickspike wheatgrass	ELLAL	<i>Elymus lanceolatus ssp. lanceolatus</i>	0-65	-
2	Needlegrasses			33-65	
	needle and thread	HECOC8	<i>Hesperostipa comata ssp. comata</i>	33-65	-
	green needlegrass	NAVI4	<i>Nassella viridula</i>	0-7	-
3	Short Warm Season			195-325	
	blue grama	BOGR2	<i>Bouteloua gracilis</i>	195-293	-
	buffalograss	BODA2	<i>Bouteloua dactyloides</i>	33-98	-
4	Grass-likes			98-163	
	threadleaf sedge	CAFI	<i>Carex filifolia</i>	98-163	-
	Grass-like (not a true grass)	2GL	<i>Grass-like (not a true grass)</i>	0-33	-
5	Other Native Grasses			33-130	
	saltgrass	DISP	<i>Distichlis spicata</i>	33-98	-
	prairie Junegrass	KOMA	<i>Koeleria macrantha</i>	20-46	-
	Sandberg bluegrass	POSE	<i>Poa secunda</i>	0-33	-
	Grass, perennial	2GP	<i>Grass, perennial</i>	0-33	-
	dropseed	SPORO	<i>Sporobolus</i>	0-33	-
	sideoats grama	BOCU	<i>Bouteloua curtipendula</i>	0-13	-
	prairie sandreed	CALO	<i>Calamovilfa longifolia</i>	0-7	-
	little bluestem	SCSC	<i>Schizachyrium scoparium</i>	0-7	-
6	Non-native Grasses			0-33	
	cheatgrass	BRTE	<i>Bromus tectorum</i>	0-33	-

	Kentucky bluegrass	POPR	<i>Poa pratensis</i>	0–33	–
Forb					
7	Forbs			33–65	
	common yarrow	ACMI2	<i>Achillea millefolium</i>	13–33	–
	white sagebrush	ARLU	<i>Artemisia ludoviciana</i>	13–33	–
	scurfpea	PSORA2	<i>Psoraleidium</i>	7–20	–
	scarlet globemallow	SPCO	<i>Sphaeralcea coccinea</i>	7–20	–
	white heath aster	SYER	<i>Symphotrichum ericoides</i>	7–20	–
	American vetch	VIAM	<i>Vicia americana</i>	7–13	–
	upright prairie coneflower	RACO3	<i>Ratibida columnifera</i>	7–13	–
	leafy wildparsley	MUDI	<i>Musineon divaricatum</i>	7–13	–
	woolly plantain	PLPA2	<i>Plantago patagonica</i>	0–13	–
	desertparsley	LOMAT	<i>Lomatium</i>	7–13	–
	onion	ALLIU	<i>Allium</i>	7–13	–
	Forb, perennial	2FP	<i>Forb, perennial</i>	0–13	–
	Forb, annual	2FA	<i>Forb, annual</i>	0–7	–
	rosy pussytoes	ANRO2	<i>Antennaria rosea</i>	0–7	–
	rush skeletonplant	LYJU	<i>Lygodesmia juncea</i>	0–7	–
	wavyleaf thistle	CIUN	<i>Cirsium undulatum</i>	0–7	–
	Missouri goldenrod	SOMI2	<i>Solidago missouriensis</i>	0–7	–
	deathcamas	ZIGAD	<i>Zigadenus</i>	0–7	–
Shrub/Vine					
8	Shrubs			33–98	
	plains pricklypear	OPPO	<i>Opuntia polyacantha</i>	33–65	–
	silver sagebrush	ARCA13	<i>Artemisia cana</i>	0–46	–
	big sagebrush	ARTR2	<i>Artemisia tridentata</i>	0–46	–
	prairie sagewort	ARFR4	<i>Artemisia frigida</i>	13–33	–
	broom snakeweed	GUSA2	<i>Gutierrezia sarothrae</i>	7–33	–
	brittle pricklypear	OPFR	<i>Opuntia fragilis</i>	0–20	–
	Subshrub (<.5m)	2SUBS	<i>Subshrub (<.5m)</i>	0–20	–
	rubber rabbitbrush	ERNA10	<i>Ericameria nauseosa</i>	0–7	–
Moss					
9	Cryptogams			0–26	
	lesser spikemoss	SEDE2	<i>Selaginella densa</i>	0–26	–

Animal community

The following table lists annual suggested initial stocking rates with average growing conditions. These are conservative estimates that should be used only as guidelines in the initial stages of conservation planning. Often, the current plant composition does not entirely match any particular plant community (as described in this Ecological Site Description). Therefore, a resource inventory is necessary to document plant composition and production. More accurate carrying capacity estimates should eventually be calculated using the following stocking rate information along with animal preference data and actual stocking records, particularly when grazers other than cattle are involved. With consultation of the land manager, more intensive grazing management may result in improved harvest efficiencies and increased carrying capacity.

Plant Community = Rhizomatous Wheatgrass-Needlegrass-Blue Grama (1.1)
Average Annual Production (lbs./ac, air-dry) = 1400
Stocking Rate (AUM/ac) = 0.40

Plant Community = Blue Grama-Rhizomatous Wheatgrass (1.2)
Average Annual Production (lbs./ac, air-dry) = 1000
Stocking Rate (AUM/ac) = 0.27

Plant Community = Blue Grama/Sedge/Pricklypear Cactus (2.1)
Average Annual Production (lbs./ac, air-dry) = 650
Stocking Rate (AUM/ac) = 0.18

Plant Community = Threeawn-Annuals (2.2)
Average Annual Production (lbs./ac, air-dry) = Variable

*Based on 912 lbs./acre (air-dry weight) per Animal Unit Month (AUM), and on 25 percent harvest efficiency of preferred and desirable forage species (refer to USDA NRCS, National Range and Pasture Handbook).

Total annual production on-site may contain vegetation deemed undesirable or untargeted by the grazing animal. Therefore, AUM values may have been reduced to reflect only preferred or desirable forage species.

Grazing by domestic livestock is one of the major income-producing industries in the area. Rangeland in this area may provide yearlong forage. During the dormant period, the forage for livestock will likely be lacking protein to meet livestock requirements, and added protein will allow ruminants to better utilize the energy stored in grazed plant materials. A forage quality test (either directly or through fecal sampling) should be used to determine the level of supplementation needed.

Hydrological functions

Water is the principal factor limiting herbage production on this site. Soils on this site are in Hydrologic Soil Groups C and D. Infiltration and runoff potential for this site varies from moderate to high depending on soil hydrologic group, slope, and ground cover. In many cases, areas with greater than 75 percent ground cover have the greatest potential for higher infiltration and lower runoff. An exception would be where shortgrasses form a dense sod and dominate the site. Normally, areas where ground cover is less than 50 percent have the greatest potential to have reduced infiltration and higher runoff (refer to Section 4, NRCS National Engineering Handbook for runoff quantities and hydrologic curves).

Recreational uses

This site provides hunting opportunities for upland game species. The wide variety of plants which bloom from spring until fall have an esthetic value that appeals to many visitors.

Other products

Seed harvest of native plant species can provide additional income on this site.

Other information

Revision Notes: "Previously Approved" Provisional

This Provisional ecological site concept has passed Quality Control (QC) and Quality Assurance (QA) to ensure that the site meets the 2014 NESH standards for a Provisional ecological site. This is an updated "Previously Approved" ESD which represents a first-generation tier of documentation that, prior to the release of the 2014 National Ecological Site Handbook (NESH), met all requirements as an "Approved" ESD as laid out in the 1997, rev.1, 2003 National Range and Pasture Handbook (NRPH). The document fully described the Reference State and Community Phase in the State-and-Transition model. All other alternative states are at least described in narrative form. The "Previously Approved" ESD has been field-tested for a minimum of five years and is a proven functional document for conservation planning. The "Previously Approved" ESD does not contain all tabular and narrative entries as required in the current "Approved" level of documentation but it is expected that the "Previously Approved" ESD will

continue refinement towards an “Approved” status.

Site Development and Testing Plan:

Future work, as described in a Project Plan, is needed to validate the information in this Provisional Ecological Site Description. This will include field activities to collect low-, medium-, and high-intensity sampling, soil correlations, and analysis of that data. Annual field reviews should be done by soil scientists and vegetation specialists. The final field review, peer review, quality control, and quality assurance reviews of the ESD will be needed to produce the final document.

Non-discrimination Statement

In accordance with Federal civil rights law and U.S. Department of Agriculture (USDA) civil rights regulations and policies, the USDA, its Agencies, offices, and employees, and institutions participating in or administering USDA programs are prohibited from discriminating based on race, color, national origin, religion, sex, gender identity (including gender expression), sexual orientation, disability, age, marital status, family/parental status, income derived from a public assistance program, political beliefs, or reprisal or retaliation for prior civil rights activity,

in any program or activity conducted or funded by USDA (not all bases apply to all programs). Remedies and complaint filing deadlines vary by program or incident.

Persons with disabilities who require alternative means of communication for program information (e.g., Braille, large print, audiotape, American Sign Language, etc.) should contact the responsible Agency or USDA's TARGET Center at (202) 720-2600 (voice and TTY) or contact USDA through the Federal Relay Service at (800) 877-8339. Additionally, program information may be made available in languages other than English.

To file a program discrimination complaint, complete the USDA Program Discrimination Complaint Form, AD-3027, available online and at any USDA office, or write a letter addressed to USDA and provide in the letter all of the information requested in the form. To request a copy of the complaint form, call (866) 632- 9992. Submit your completed form or letter to USDA by: (1) mail: U.S. Department of Agriculture, Office of the Assistant Secretary for Civil Rights, 1400 Independence Avenue, SW, Washington, D.C. 20250-9410; (2) fax: (202) 690-7442; or (3) email: program.intake@usda.gov.

Inventory data references

Information presented here has been derived from NRCS clipping data and other inventory data. Field observations from range-trained personnel were also used. Those involved in developing this site description include: Stan Boltz, Range Management Specialist, NRCS; Cheryl Nielsen, Range Management Specialist, NRCS; Rick Peterson, Range Management Specialist, NRCS; Mike Stirling, Range Management Specialist, NRCS.

Two - Data Source Records:

SCS-RANGE-417 1981 Meade Co, SD

SCS-Range-417 1981 Pennington Co, SD

Other references

EPA – Level III and Level IV Ecoregions of the Continental United States, (<https://www.epa.gov/eco-research/level-iii-and-iv-ecoregions-continental-united-states>). Available online. Accessed 01/03/17

High Plains Regional Climate Center, University of Nebraska, (<http://www.hprcc.unl.edu/>). Available online. Accessed 02/27/17.

USDA, NRCS. Soil Survey Staff. Official Soil Series Descriptions. Available online. Accessed 03/20/17.

USDA, NRCS. Soil Survey Staff. Web Soil Survey. Available online. Accessed 03/20/17.

USDA, NRCS. 2006. Land Resource Regions and Major Land Resource Areas of the United States, the Caribbean, and the Pacific Basin. Ag Handbook 296.

USDA, NRCS. 2014. National Ecological Site Handbook, 1st Ed.

USDA, NRCS. National Water and Climate Center. (<http://www.wcc.nrcs.usda.gov/>). Available online. Accessed 03/22/17.

USDA, NRCS. 1997, rev. 1, 2003. National Range and Pasture Handbook.

USDA, NRCS. National Soil Information System, Information Technology Center. (<http://nasis.nrcs.usda.gov>).

USDA, NRCS. 2017. The PLANTS Database (<http://plants.usda.gov>, July 2017). Available online. Accessed 3/3/17.

USDA, NRCS. Various Published Soil Surveys.

Contributors

Stan Boltz

Approval

Suzanne Mayne-Kinney, 6/25/2024

Acknowledgments

ESD Updated by Rick L. Peterson 4/14/17

MLRA 60A Provisional Level Quality Control (QC) Process 9/28/17

Ecological Site from MLRA 60A were Previously Approved ESDs and meet the requirements as stated in the 2003 National Range and Pasture Handbook.

The Sites were updated to the Provisional Level by Rick L. Peterson, ESS, Rapid City, SSO in FY17.

The sites were reviewed by George Gamblin, RMS, Wheatland, WY and Mitch Faulkner, RMS, Belle Fourche, SD. Mitch Faulkner acted as the Provisional QC. The Sites were then reviewed and approved at the Provisional Level by David Kraft, Regional ESS, Salina, KS.

Worked closely with Kent Cooley, Area SS, with MLRA key development and soils narratives

Rangeland health reference sheet

Interpreting Indicators of Rangeland Health is a qualitative assessment protocol used to determine ecosystem condition based on benchmark characteristics described in the Reference Sheet. A suite of 17 (or more) indicators are typically considered in an assessment. The ecological site(s) representative of an assessment location must be known prior to applying the protocol and must be verified based on soils and climate. Current plant community cannot be used to identify the ecological site.

Author(s)/participant(s)	Stan Boltz, Ryan Beer, Mitch Iverson, Thad Berrett, Cheryl Nielsen
Contact for lead author	stanley.boltz@sd.usda.gov, 605-352-1236
Date	06/04/2008
Approved by	Suzanne Mayne-Kinney
Approval date	
Composition (Indicators 10 and 12) based on	Annual Production

Indicators

1. **Number and extent of rills:** None.

2. **Presence of water flow patterns:** None, or barely visible and discontinuous.

3. **Number and height of erosional pedestals or terracettes:** None.

4. **Bare ground from Ecological Site Description or other studies (rock, litter, lichen, moss, plant canopy are not bare ground):** 0 to 15 percent is typical.

5. **Number of gullies and erosion associated with gullies:** None should be present.

6. **Extent of wind scoured, blowouts and/or depositional areas:** None.

7. **Amount of litter movement (describe size and distance expected to travel):** Litter should fall in place. Slight amount of movement of smallest size class litter is possible, but not normal.

8. **Soil surface (top few mm) resistance to erosion (stability values are averages - most sites will show a range of values):** Soil aggregate stability ratings should typically be 5 to 6, normally 6. Surface organic matter adheres to the soil surface. Soil surface fragments will typically retain structure indefinitely when dipped in distilled water.

9. **Soil surface structure and SOM content (include type of structure and A-horizon color and thickness):** A-horizon should be 3 to 6 inches thick with mollic (dark) colors when moist. Structure typically is medium to fine granular at least in the upper A-horizon.

10. **Effect of community phase composition (relative proportion of different functional groups) and spatial distribution on infiltration and runoff:** Combination of shallow and deep rooted species (mid & tall rhizomatous and tufted perennial cool-season grasses) with fine and coarse roots positively influences infiltration.

11. **Presence and thickness of compaction layer (usually none; describe soil profile features which may be mistaken for compaction on this site):** None – natural pan appears at roughly 4 to 16 inches with “biscuit-top” appearance at top of pan.

12. **Functional/Structural Groups (list in order of descending dominance by above-ground annual-production or live foliar cover using symbols: >>, >, = to indicate much greater than, greater than, and equal to):**

Dominant: Mid cool-season rhizomatous grasses >>

Sub-dominant: Mid cool-season bunchgrasses = short warm-season grasses >

Other: Forbs > shrubs

Additional:

13. **Amount of plant mortality and decadence (include which functional groups are expected to show mortality or decadence):** Very little evidence of decadence or mortality. Bunch grasses have strong, healthy centers and shrubs are vigorous.
-

14. **Average percent litter cover (%) and depth (in):**
-

15. **Expected annual annual-production (this is TOTAL above-ground annual-production, not just forage annual-production):** Production ranges from 900-2,000 lbs./acre (air-dry weight). Reference value production is 1,400 lbs./acre (air-dry weight).
-

16. **Potential invasive (including noxious) species (native and non-native). List species which BOTH characterize degraded states and have the potential to become a dominant or co-dominant species on the ecological site if their future establishment and growth is not actively controlled by management interventions. Species that become dominant for only one to several years (e.g., short-term response to drought or wildfire) are not invasive plants. Note that unlike other indicators, we are describing what is NOT expected in the reference state for the ecological site:** State and local noxious weeds
-

17. **Perennial plant reproductive capability:** All species exhibit high vigor relative to climatic conditions. Do not rate based solely on seed production. Perennial grasses should have vigorous rhizomes or tillers.
-