

Ecological site R060BE580MT

Loamy Saline 10-14

Last updated: 9/07/2023
Accessed: 05/04/2024

General information

Provisional. A provisional ecological site description has undergone quality control and quality assurance review. It contains a working state and transition model and enough information to identify the ecological site.

MLRA notes

Major Land Resource Area (MLRA): 060B–Pierre Shale Plains, Northern Part

MLRA 060B, Pierre Shale Plains (Northern Part), is almost entirely in Montana (94 percent) and Wyoming (6 percent). The area makes up about 2,160,000 acres and occurs in the uplands between most of the major rivers in southeastern Montana and northeastern Wyoming. The area is within the Missouri Plateau, Unglaciaded, Section of the Great Plains Province of the Interior Plains. It is an area of old plateaus and terraces that have been deeply eroded.

The shale plains have long, smooth, gentle to strong slopes. Slopes along drainageways and streams are moderately steep or steep. Elevation ranges from 1,900 to 3,500 feet on uplands. Marine and continental sediments of the Cretaceous Montana Group underlie most of this MLRA.

The average annual precipitation in the area is 14 inches and ranges from 11 to 17 inches. Most of the annual precipitation occurs as high-intensity, convective thunderstorms during the growing season. Precipitation in winter occurs mainly as snow, which usually is accompanied by high winds that cause much drifting.

The average annual temperature is 43 to 46 degrees Fahrenheit. The freeze-free period averages 142 days and ranges from 130 to 160 days. The frost-free period averages 120 days and ranges from 110 to 135 days.

The dominant soil orders in this MLRA are Alfisols, Entisols, and Vertisols. The soils in the area dominantly have a frigid soil temperature regime, an ustic soil moisture regime, and smectitic mineralogy. The soils are shallow to very deep, generally well drained, and clayey.

The area supports native prairie vegetation characterized by a diversity of cool-season and warm-season grasses, sedges, forbs, and shrubs. A majority of this area is in farms or ranches and comprised of rangeland used for livestock grazing. Some small areas of nearly level to moderately sloping soils are used for winter wheat or for livestock feed crops.

Classification relationships

NRCS Soil Geography Hierarchy

- Land Resource Region: Western Great Plains
- Major Land Resource Area (MLRA): 060B Pierre Shale Plains, Northern Part

National Hierarchical Framework of Ecological Units (Cleland et al., 1997; McNab et al., 2007)

- Domain: Dry
- Division: Temperate Steppe
- Province: Great Plains-Palouse Dry Steppe Province (331)
- Section: North Central Highlands (331K) and Missouri Plateau Section (331M)

National Vegetation Classification Standard (Federal Geographic Data Committee, 2008)

- Class: Xeromorphic Woodland, Scrub and Herb Vegetation Class (3)
- Subclass: Cool Semi-Desert Scrub and Grassland Subclass (3.B)
- Formation: Cool Semi-Desert Scrub and Grassland Formation (3.B.1)
- Division: Cool Semi-Desert Scrub and Grassland Division (3.B.1.Ne)
- Macrogroup: *Artemisia tridentata* - *Artemisia tripartita* ssp. *tripartita* - *Purshia tridentata* Steppe and Shrubland Macrogroup (3.B.1.Ne.3)
- Group: *Artemisia tridentata* ssp. *wyomingensis* - *Artemisia tridentata* ssp. *tridentata* Steppe & Shrubland Group (3.B.1.Ne.3.a)

EPA Ecoregions

- Level 1: Great Plains (9)
- Level 2: West-Central Semi-Arid Prairies (9.3)
- Level 3: Northwestern Great Plains (9.3.3)
- Level 4: Sagebrush Steppe (43e)

Ecological site concept

This ecological site occurs on nearly level to rolling sedimentary plains, terraces and fans at elevations ranging from 1,900 to 3,500 feet. Slopes range from 0 to 15 percent but are generally less than 8 percent. This site occurs on all aspects, although aspect is not a significant factor. In their natural condition, the soils associated with this ecological site appear very similar to a normal loamy ecological site. The subsoils are strongly alkaline, usually within 6 to 12 inches of the surface. The soils tend to be slightly to moderately saline and very strongly alkaline in the upper 24 to 30 inches. The soils on this site are moderately deep to very deep and are well drained. The soil surface textures are typically loam, silt loam, or silty clay loam.

Associated sites

R060BE566MT	Clayey 10-14 The Clayey ecological site has soils with greater than 35 percent clay content and has a lesser component of salt tolerant plants. The Clayey ecological site is located on similar landform positions as the Loamy Saline ecological site.
R060BE565MT	Claypan 10-14 The Claypan ecological site has a natric horizon and columnar structure within 4 to 8 inches of the soil surface which severely limits both root penetration and infiltration. The Claypan ecological site is located on similar landforms positions as the Loamy Saline ecological site.
R060BE572MT	Saline Upland 10-14 The Saline Upland ecological site generally occurs on slopes of less than 20 percent, but may range up to 35 or 40 percent. The Saline Upland ecological site is dominated by salt tolerant species and the amount of plant cover and production is significantly less. The Saline Upland ecological site is located on similar landform positions as the Loamy Saline ecological site.
R060BE579MT	Loamy 10-14 The Loamy ecological site has a lesser component of salt tolerant plants. The Loamy ecological site is located on similar landform positions as the Loamy Saline ecological site.

Similar sites

R060BE579MT	Loamy 10-14 The Loamy ecological site has a lesser component of salt tolerant plants. The Loamy ecological site is located on similar landform positions as the Loamy Saline ecological site.
R060BE566MT	Clayey 10-14 The Clayey ecological site has soils with greater than 35 percent clay content and has a lesser component of salt tolerant plants. The Clayey ecological site is located on similar landform positions as the Loamy Saline ecological site.

R060BE571MT	<p>Saline Lowland 10-14</p> <p>The Saline Lowland ecological site is dominated by salt tolerant species and the amount of plant cover and production is significantly greater due to the extra moisture this site receives. The Saline Lowland ecological site is located on lower landform positions than the Loamy Saline ecological site.</p>
R060BE572MT	<p>Saline Upland 10-14</p> <p>The Saline Upland ecological site generally occurs on slopes of less than 20 percent, but may range up to 35 or 40 percent. The Saline Upland ecological site is dominated by salt tolerant species and the amount of plant cover and production is significantly less. The Saline Upland ecological site is located on similar landform positions as the Loamy Saline ecological site.</p>

Table 1. Dominant plant species

Tree	Not specified
Shrub	(1) <i>Artemisia tridentata ssp. wyomingensis</i> (2) <i>Sarcobatus vermiculatus</i>
Herbaceous	(1) <i>Pascopyrum smithii</i>

Physiographic features

This ecological site occurs on nearly level to rolling sedimentary plains, terraces and fans at elevations ranging from 1,900 to 3,500 feet. Slopes range from 0 to 15 percent but are generally less than 8 percent. This site occurs on all aspects, although aspect is not a significant factor.

Table 2. Representative physiographic features

Landforms	(1) Plain (2) Terrace (3) Fan
Runoff class	Low to medium
Flooding frequency	None
Ponding frequency	None
Elevation	1,900–3,500 ft
Slope	0–15%
Water table depth	60–72 in
Aspect	Aspect is not a significant factor

Climatic features

MLRA 060B is a semi-arid region and is considered to have a continental climate characterized by cold winters, hot summers, low humidity, light rainfall, and much sunshine. The climate is the result of the MLRA's location in the geographic center of North America. Temperatures can be extreme.

The average annual temperature is 43 to 46 degrees Fahrenheit. Summer daytime temperatures are typically quite warm, generally averaging in the lower to mid-80's for July and August. Summertime temperatures will typically reach 100 degrees or more at some point during the summer and can reach 90 degrees during any month between May and September. Conversely, winter temperatures can be cold, averaging in the mid-teens to mid-20's for December and January. There will typically be several days of below zero temperatures each winter. It is not uncommon for temperatures to reach 30 to 40 degrees below zero, or even colder, most any winter.

The average annual precipitation in this area is 14 inches, and ranges from 11 to 17 inches. During an average year, 70 to 75 percent of the annual precipitation falls between April and September, which are the primary growing season months. A majority of the annual precipitation occurs as frontal storms early in the growing season during the months of May and June and high-intensity, convective thunderstorms during July and August. Some rainfall occurs during the fall. Seasonal precipitation is often limiting for plant growth.

Annual fluctuations in species composition and total production are typical depending on the amount and timing of rainfall. Precipitation during the winter occurs primarily as snow, although snowfall is generally not heavy. Snow cover is typically 1 to 3 inches. Heavy snowfall occurs infrequently, usually late in the winter or early spring. Snowfall is generally accompanied by high winds that causes drifting.

The prevailing wind direction is from the northwest. Precipitation fluctuates widely from year to year and severe drought occurs 2 out of 10 years on average. There are few natural barriers on the northern Great Plains and the winds move freely across the plains and account for rapid changes in temperature. Spring can be windy throughout the MLRA, with winds averaging over 10 mph about 15 percent of the time. Speeds of 50 mph or stronger can occasionally occur.

For local climate station information, refer to <https://wrcc.dri.edu/summary/Climsmemt.html>.

Table 3. Representative climatic features

Frost-free period (characteristic range)	110-135 days
Freeze-free period (characteristic range)	130-160 days
Precipitation total (characteristic range)	10-14 in
Frost-free period (actual range)	
Freeze-free period (actual range)	
Precipitation total (actual range)	10-17 in
Frost-free period (average)	120 days
Freeze-free period (average)	142 days
Precipitation total (average)	14 in

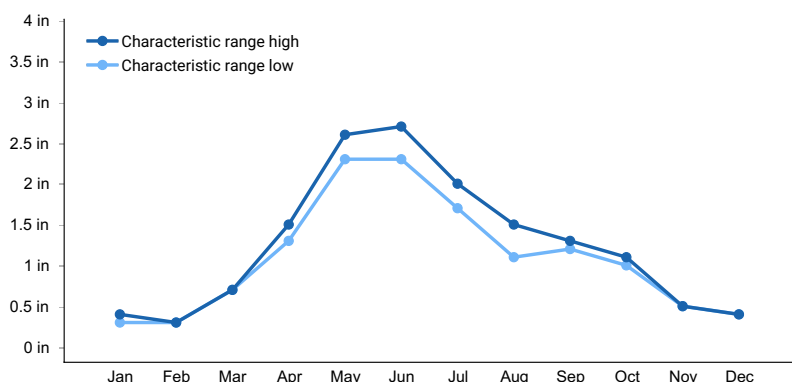

Figure 1. Monthly precipitation range

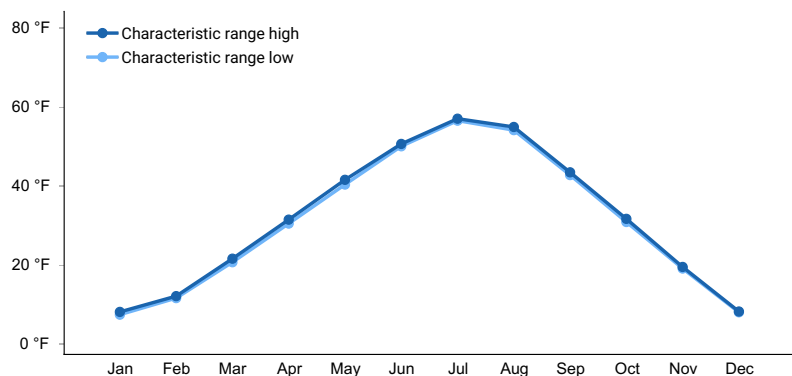

Figure 2. Monthly minimum temperature range

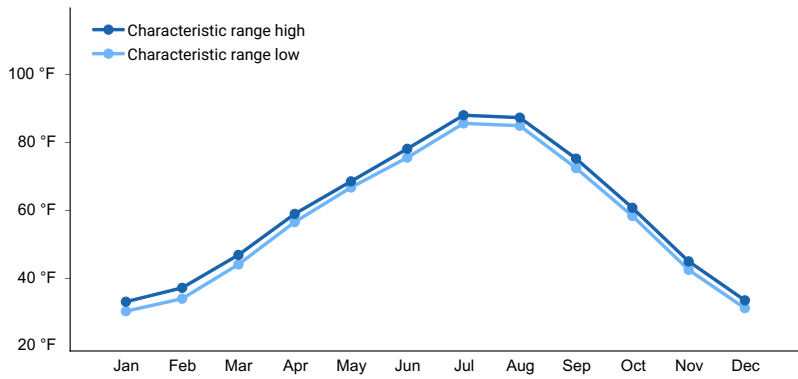

Figure 3. Monthly maximum temperature range

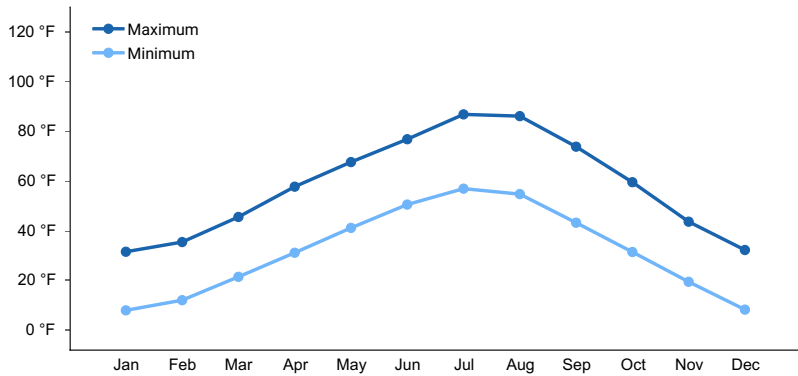

Figure 4. Monthly average minimum and maximum temperature

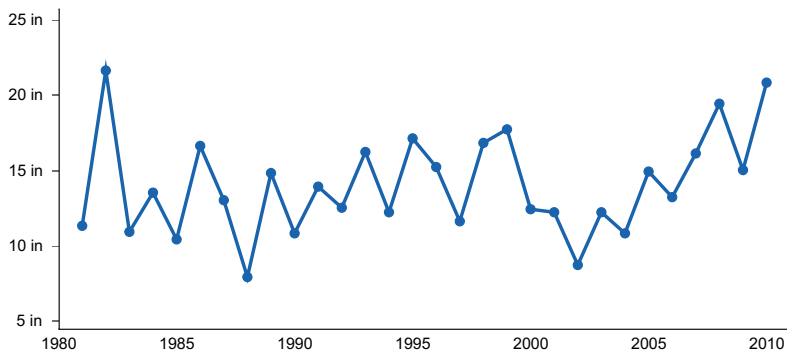

Figure 5. Annual precipitation pattern

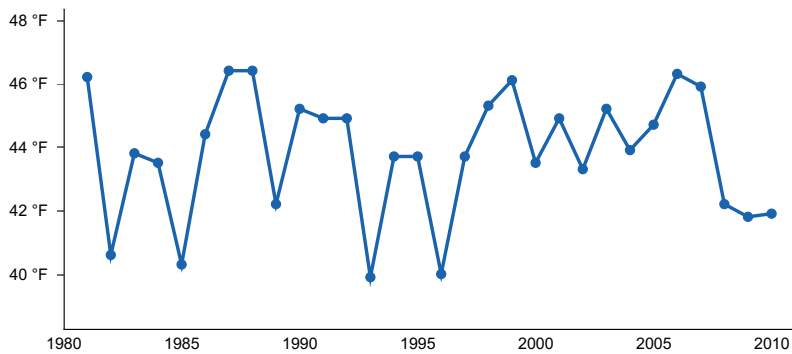

Figure 6. Annual average temperature pattern

Climate stations used

- (1) INGOMAR 14 NE [USC00244386], Ingomar, MT
- (2) RIDGEWAY 1 S [USC00247034], Hammond, MT
- (3) ALBION 1 N [USC00240088], Alzada, MT

- (4) BAKER MUNI AP [USW00094055], Baker, MT

Influencing water features

This upland ecological site is not influenced by a water table or run in from adjacent sites. Due to the semi-arid climate in which it occurs, the water budget is normally contained within the soil pedon. Soil moisture is recharged by spring rains, but it rarely exceeds field capacity in the upper 40 inches before being depleted by evapotranspiration. During intense precipitation events, precipitation rates frequently exceed infiltration rates and the site delivers moisture to downslope sites through surface runoff. Moisture loss through evapotranspiration exceeds precipitation for a majority of the growing season. Soil moisture is the primary limiting factor for vegetative production on this ecological site.

Wetland description

Not Applicable

Soil features

In their natural condition, the soils associated with this ecological site appear very similar to a normal loamy ecological site. The subsoils are strongly alkaline, usually within 6 to 12 inches of the surface. The soils tend to be slightly to moderately saline and very strongly alkaline in the upper 24 to 30 inches. The soils on this site are moderately deep to very deep and are well drained. The soil textures are typically loam, silt loam, or silty clay loam. The soil temperature regime is primarily frigid and the soil moisture regime is aridic ustic.

Table 4. Representative soil features

Parent material	(1) Alluvium–sedimentary rock
Surface texture	(1) Loam (2) Silt loam (3) Silty clay loam
Drainage class	Well drained
Permeability class	Moderately slow
Depth to restrictive layer	20–72 in
Soil depth	20–72 in
Surface fragment cover ≤3"	0–5%
Surface fragment cover >3"	0–3%
Available water capacity (0-40in)	5–8 in
Electrical conductivity (0-20in)	2–20 mmhos/cm
Sodium adsorption ratio (0-20in)	2–40
Subsurface fragment volume ≤3" (0-20in)	0–10%
Subsurface fragment volume >3" (0-20in)	0–5%

Ecological dynamics

The Reference State is the plant community in which interpretations are primarily based and is used as a reference in order to understand the original potential of the site. The Reference State evolved under the combined influences of climatic conditions, periodic fire activity, grazing by large herbivores, and impacts from small mammals and insects. Changes may occur to the Reference State due to management actions such as improper grazing management, climatic conditions such as drought, and natural events such as multiple fires in close succession.

The Reference Plant Community for this ecological site is dominated by a diversity of tall and medium height, cool-season and warm-season grasses which are tightly intermixed and well distributed over the site. Various forbs, half-shrubs, and shrubs are common on this site. The Reference Plant Community is not necessarily the management goal, as other vegetative states may be considered desired plant communities as long as critical resource concerns are met.

In addition to the Reference State, other plant communities can occur on this site and are usually the result of historic management practices. Long term overgrazing on this ecological site results in a decrease of tallgrasses, mid-grasses, and more palatable forbs and in an increase of shortgrasses, sedges, and less palatable forbs. Half-shrubs and shrubs increase in the absence of prescribed fire and wildfire. More frequent fire intervals decreases the shrub component resulting in a site dominated by herbaceous species. There are various transitional stages which may occur on this ecological site.

State and transition model

Ecosystem states

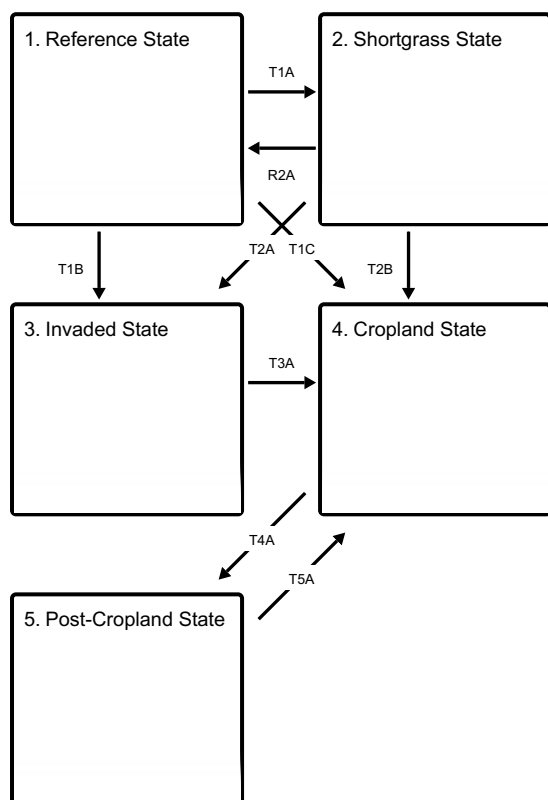

T1A - Prolonged drought, improper grazing, or a combination of these factors

T1B - Introduction of non-native, invasive species (annual bromes, crested wheatgrass, noxious weeds)

T1C - Tillage or herbicide application and seeding of annual crops or non-native hayland (frequently combined with irrigation practices)

R2A - Proper grazing management in combination with rangeland seeding, grazing land mechanical treatment, and timely moisture (management intensive and costly)

T2A - Introduction of non-native, invasive species (annual bromes, crested wheatgrass, noxious weeds)

T2B - Tillage or herbicide application and seeding of annual crops or non-native hayland (frequently combined with irrigation practices)

T3A - Tillage or herbicide application and seeding of annual crops or non-native hayland (frequently combined with irrigation practices)

T4A - Cessation of annual cropping

T5A - Tillage or herbicide application and seeding of annual crops or non-native hayland (frequently combined with irrigation practices)

State 1 submodel, plant communities

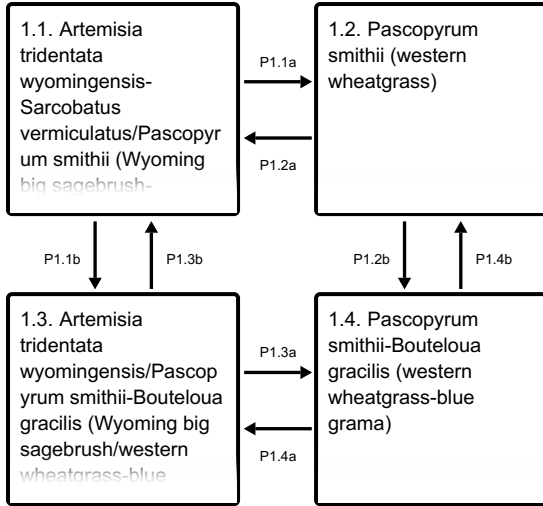

- P1.1a** - Prescribed fire and wildfire, mechanical and chemical treatments, biological processes
- P1.1b** - Drought, improper grazing management
- P1.2a** - Approximately 30 years post-fire regrowth
- P1.2b** - Drought, improper grazing management, multiple fires in close succession
- P1.3b** - Normal or above average precipitation, proper grazing management
- P1.3a** - Prescribed fire and wildfire, mechanical and chemical treatments, biological processes
- P1.4b** - Normal or above average precipitation; proper grazing management
- P1.4a** - Approximately 30 years post-fire regrowth

State 2 submodel, plant communities

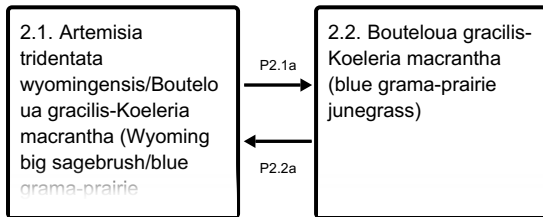

- P2.1a** - Prescribed fire and wildfire, mechanical and chemical treatments, biological processes
- P2.2a** - Approximately 30 years post-fire regrowth

State 3 submodel, plant communities

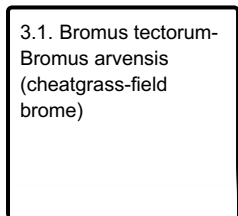

State 4 submodel, plant communities

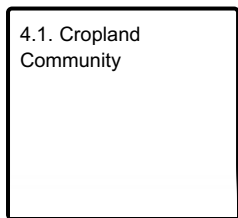

State 5 submodel, plant communities

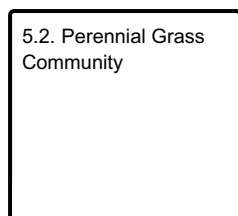
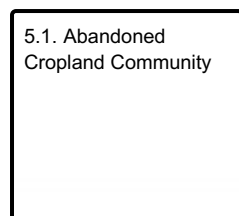

State 1 Reference State

The Reference State (1) evolved under the combined influences of climatic conditions, periodic fire activity, grazing by large herbivores, and impacts from small mammals and insects. The Reference State is the plant community in which interpretations are primarily based and is used as a reference in order to understand the original potential of the site. The Reference State (1) for this ecological site consists of 4 community phases.

Community 1.1

***Artemisia tridentata wyomingensis*-*Sarcobatus vermiculatus*/*Pascopyrum smithii* (Wyoming big sagebrush-greasewood/western wheatgrass)**

This plant community is characterized by a mixed-grass community and shrub species. The predominant species are cool-season grasses such as western wheatgrass, green needlegrass, and needle and thread, and warm-season grasses such as alkali sacaton. Shortgrasses and sedges such as inland saltgrass, prairie junegrass, plains reedgrass, Sandberg bluegrass, blue grama, buffalograss, threadleaf sedge, and needleleaf sedge are present at low cover. Forbs such as scarlet globemallow and American vetch occur at approximately 5 to 10 percent canopy cover. Shrubs and half-shrubs such as Wyoming big sagebrush, greasewood, winterfat, and Nuttall's saltbush occur at approximately 5 to 15 percent canopy cover.

Community 1.2

***Pascopyrum smithii* (western wheatgrass)**

This plant community is characterized by rhizomatous wheatgrass and mid-statured bunchgrass communities including cool-season species such as western wheatgrass, green needlegrass, and needle and thread, and warm-season species such as alkali sacaton. Shortgrasses and sedges such as inland saltgrass, prairie junegrass, plains reedgrass, Sandberg bluegrass, blue grama, buffalograss, threadleaf sedge, and needleleaf sedge occur at low cover. Forbs such as scarlet globemallow and American vetch occur at approximately 5 to 10 percent canopy cover. Wyoming big sagebrush is absent to rare. This community phase occurs when the plant community is burned by either wildfire or prescribed fire and may persist as long as 30 years following the burn (Watts, M.J., and C.L. Wambolt. 1996).

Community 1.3

***Artemisia tridentata wyomingensis*/*Pascopyrum smithii*-*Bouteloua gracilis* (Wyoming big sagebrush/western wheatgrass-blue grama)**

This plant community phase is characterized by an increase in shortgrass species and sedges such as inland saltgrass, prairie junegrass, plains reedgrass, Sandberg bluegrass, blue grama, buffalograss, threadleaf sedge, and needleleaf sedge and a decrease in mid-statured grasses such as western wheatgrass, green needlegrass, needle and thread, and alkali sacaton. Prairie sagewort occurs at low to moderate cover and Wyoming big sagebrush occurs at approximately 5 to 20 percent canopy cover.

Community 1.4

***Pascopyrum smithii*-*Bouteloua gracilis* (western wheatgrass-blue grama)**

This plant community is characterized by an increase in shortgrass species and sedges such as inland saltgrass, prairie junegrass, plains reedgrass, Sandberg bluegrass, blue grama, buffalograss, threadleaf sedge, and needleleaf sedge and a decrease in mid-statured grasses such as western wheatgrass, green needlegrass, needle and thread, and alkali sacaton. Prairie sagewort occurs at low to moderate cover and Wyoming big sagebrush is

absent to rare. This community phase occurs when site conditions decline due to long-term drought or improper grazing management, and a fire has occurred on the site less than 30 years prior.

Pathway P1.1a **Community 1.1 to 1.2**

Community Phase 1.1 will transition to Community Phase 1.2 through prescribed fire and wildfire, mechanical and chemical treatments, and biological processes. Wyoming big sagebrush is greatly reduced and perennial grasses will dominate the site.

Pathway P1.1b **Community 1.1 to 1.3**

Drought, improper grazing practices such as continuous season-long or year-long grazing, or a combination of these factors can shift Community Phase 1.1 to Community Phase 1.3. These factors favor an increase in shortgrasses such as blue grama and a decrease in cool-season mid-statured grasses. Wyoming big sagebrush cover will be similar to Community Phase 1.1.

Pathway P1.2a **Community 1.2 to 1.1**

Approximately 30 years or more of natural vegetative regrowth will transition Community Phase 1.2 to Community Phase 1.1. Approximately 30 years or more without fire allows Wyoming big sagebrush to recolonize the site.

Pathway P1.2b **Community 1.2 to 1.4**

Drought, improper grazing practices such as continuous season-long or year-long grazing, multiple fires in close succession, or a combination of these factors can shift Community Phase 1.2 to Community Phase 1.3. These factors favor an increase in blue grama and a decrease in cool-season mid-statured grasses. Wyoming big sagebrush cover will be similar to Community Phase 1.2.

Pathway P1.3a **Community 1.3 to 1.1**

Approximately 30 years or more post-fire, normal or above average precipitation, and proper grazing management transitions Community Phase 1.3 to Community Phase 1.1. This transition may also occur through natural succession.

Pathway P1.3a **Community 1.3 to 1.4**

Community Phase 1.3 will transition to Community Phase 1.4 through prescribed fire and wildfire, mechanical and chemical treatments, and biological processes. Wyoming big sagebrush is greatly reduced and perennial grasses will dominate the site.

Pathway P1.4a **Community 1.4 to 1.2**

Less than approximately 30 years post-fire; normal or above-average precipitation and proper grazing management transitions Community Phase 1.4 to Community Phase 1.2.

Pathway P1.4a **Community 1.4 to 1.3**

Approximately 30 years or more of natural shrub regrowth will transition Community Phase 1.4 to Community Phase 1.3. Approximately 30 years or more without prescribed fire or wildfire allows Wyoming big sagebrush to

recolonize the site.

State 2

Shortgrass State

The dynamics of the Shortgrass State (2) are driven by long-term drought, improper grazing practices such as continuous season-long or year-long grazing, or a combination of these factors. The Shortgrass State (2) for this ecological site consists of 2 community phases.

Community 2.1

***Artemisia tridentata wyomingensis*/*Bouteloua gracilis*-*Koeleria macrantha* (Wyoming big sagebrush/blue grama-prairie junegrass)**

This plant community is characterized by a dominance of shortgrasses such as inland saltgrass, prairie junegrass, plains reedgrass, Sandberg bluegrass, blue grama, and buffalograss. Mid-statured grasses such as western wheatgrass, green needlegrass, needle and thread, and alkali sacaton are rare or absent. Prairie sagewort is common and Wyoming big sagebrush canopy cover is approximately 5 to 15 percent. This community phase results in a reduction of soil surface litter, soil organic matter, and infiltration and an increase of soil surface runoff. This plant community is capable of tolerating season-long, heavy grazing and therefore is highly resistant to change.

Community 2.2

***Bouteloua gracilis*-*Koeleria macrantha* (blue grama-prairie junegrass)**

This plant community is characterized by a complete dominance of shortgrasses such as inland saltgrass, prairie junegrass, plains reedgrass, Sandberg bluegrass, blue grama, and buffalograss. Mid-statured grasses such as western wheatgrass, green needlegrass, needle and thread, and alkali sacaton are rare or absent. Prairie sagewort is common and Wyoming big sagebrush is absent or rare. This plant community occurs when site conditions decline due to long-term drought or improper grazing practices such as continuous season-long or year-long grazing, and a fire has occurred on the site less than approximately 30 years prior. This community phase results in a reduction of soil surface litter, soil organic matter, and infiltration and an increase of soil surface runoff. This plant community is capable of tolerating season-long, heavy grazing and therefore is highly resistant to change.

Pathway P2.1a

Community 2.1 to 2.2

Community Phase 2.1 will transition to Community Phase 2.2 through prescribed fire and wildfire, mechanical and chemical treatments, and biological processes. Wyoming big sagebrush is greatly reduced and perennial grasses will dominate the site.

Pathway P2.2a

Community 2.2 to 2.1

It is estimated that approximately 30 years or more of natural post-fire vegetative regrowth could transition Community Phase 2.2 to Community Phase 2.1. It is possible that this transition could occur over time, however, the processes are not fully understood at this time. Therefore, this pathway is considered hypothetical until further investigation can be completed.

State 3

Invaded State

The Invaded State (3) occurs when invasive plant species invade native plant communities and displace the native species. The Invaded State (3) consists of 1 community phase.

Community 3.1

***Bromus tectorum*-*Bromus arvensis* (cheatgrass-field brome)**

Observations suggest that native species diversity declines significantly when invasive or noxious species exceed

approximately 30 percent of the plant community. Non-native, perennial, drought tolerant grasses such as crested wheatgrass, non-native, annual, invasive species such as cheatgrass and field brome, and noxious weed species can eventually dominate the seedbank of this site and displace native species. Reduced plant species diversity, simplified structural complexity, and altered ecological processes result in a state that is substantially departed from the Reference State (1). The dominance of annual, invasive grasses such as cheatgrass and field brome increases the fire cycle frequency.

State 4 Cropland State

The Cropland State (4) occurs when cultivation occurs to the land. The Cropland State (4) consists of 1 community phase.

Community 4.1 Cropland Community

The land is cultivated and converted to crop production. Annual, cool-season cereal grains such as spring wheat, winter wheat, and barley are common crops which replace native plant communities.

State 5 Post-Cropland State

The Post-Cropland State (5) occurs when cultivated cropland is abandoned and allowed to either re-vegetate naturally or is seeded back to perennial species for livestock grazing or wildlife use. This state can transition back to the Cropland State (4) if the site is returned to cultivation. No formal studies have been obtained regarding Wyoming big sagebrush recovery following cultivation and further investigation is needed to assess Wyoming big sagebrush recovery in the Post-Cropland State (5). The Post-Cropland State (5) has 2 community phases.

Community 5.1 Abandoned Cropland Community

In the absence of active management, the site can re-vegetate naturally and potentially return to a perennial grassland community over time. Shortly after cropland is abandoned, annual and biennial forbs and annual brome grasses invade the site. The site is highly susceptible to erosion due to the absence of perennial species. Eventually, these pioneering annual species are replaced by perennial forbs and perennial shortgrasses. Depending on the historical management of the site, mid-statured perennial grasses may also return; however, species composition will depend upon the seed bank. Invasion of the site by exotic species, such as crested wheatgrass and annual bromes, will depend upon the site's proximity to a seed source. Approximately 50 or more years after cultivation, these sites may have species composition similar to phases in the Reference State (1) (Dormaar, J.F., and S. Smoliak. 1985). However, soil quality is consistently lower than conditions prior to cultivation and a shift to the Reference State (1) is unlikely.

Community 5.2 Perennial Grass Community

When the site is seeded to perennial forage species this community phase can persist for several decades. Introduced perennial grasses, in particular, may form monocultures that persist for approximately 60 years or more (Samuel, M.J., and R.H. Hart. 1994). A mixture of native species may also be seeded to provide species composition and structural complexity similar to that of the Reference State (1). However, soil quality conditions have been substantially altered and will not return to pre-cultivation conditions.

Transition T1A State 1 to 2

Prolonged drought, improper grazing management such as continuous season-long or year-long grazing, or a combination of these factors weaken the resilience of the Reference State (1) and drive its transition to the Shortgrass State (2). The Reference State (1) transitions to the Shortgrass State (2) when mid-statured graminoids

are greatly reduced and shortgrasses such as inland saltgrass, prairie junegrass, plains reedgrass, Sandberg bluegrass, blue grama, and buffalograss dominate the plant community.

Transition T1B **State 1 to 3**

The Reference State (1) transitions to the Invaded State (3) when non-native grasses or noxious weeds invade the plant community. Exotic plant species dominate the site in terms of cover and production and site resilience has been substantially reduced. In addition, other rangeland health attributes, such as reproductive capacity of native grasses and soil quality, have been substantially altered from the Reference State (1).

Transition T1C **State 1 to 4**

Tillage or application of herbicide followed by seeding of cultivated crops, such as winter wheat, spring wheat, and barley, transitions the Reference State (1) to the Cropland State (4).

Restoration pathway R2A **State 2 to 1**

Blue grama can resist displacement by other species. A reduction in livestock grazing pressure alone may not be sufficient to reduce the cover of blue grama in the Shortgrass State (3) and mechanical treatments may be necessary. Therefore, returning the Shortgrass State (2) to the Reference State (1) can require considerable cost, energy, and time.

Conservation practices

Prescribed Grazing

Transition T2A **State 2 to 3**

The Shortgrass State (2) transitions to the Invaded State (3) when non-native grasses, noxious weeds, and other invasive plants invade the Shortgrass State (2). Exotic plant species dominate the site in terms of cover and production. Site resilience has been substantially reduced.

Transition T2B **State 2 to 4**

Tillage or application of herbicide followed by seeding of cultivated crops, such as winter wheat, spring wheat, and barley, transitions the Shortgrass State (2) to the Cropland State (4).

Transition T3A **State 3 to 4**

The Invaded State (3) will transition to the Cropland State (4) when the site is placed under cultivation.

Transition T4A **State 4 to 5**

The transition from the Cropland State (4) to the Post-Cropland State (5) occurs with the cessation of cultivation. The site may also be seeded to perennial forage species, such as crested wheatgrass and alfalfa, or a mix of native species.

Transition T5A **State 5 to 4**

Tillage or application of herbicide followed by seeding of cultivated crops, such as winter wheat, spring wheat, and barley, transitions the Post-Cropland State (5) to the Cropland State (4).

Additional community tables

Inventory data references

Specific field data was not obtained for this provisional ecological site description. Existing field data was used in conjunction with a review of scientific literature and professional experience to approximate the plant communities, states, and transitions. All community phases are considered provisional based on the sources identified in this ecological site description.

Other references

Cleland, D.T., et al. 1997. National Hierarchical Framework of Ecological Units. In: M.S. Boyce and A. Haney (eds.) Ecosystem Management Applications for Sustainable Forest and Wildlife Resources, Yale University Press, New Haven, CT.

Dormaar, J.F., and S. Smoliak. 1985. Recovery of vegetative cover and soil organic matter during revegetation of abandoned farmland in a semiarid climate. *Journal of Range Management* 38:487-491.

Federal Geographic Data Committee. 2008. The National Vegetation Classification Standard, Version 2. FGDC Vegetation Subcommittee. FGDC-STD-005-2008 (Version 2). pp. 126.

Fire Effects Information System. USDA Forest Service.
<http://www.fs.fed.us/database/feis/plants/shrub/amealn/all.html>.

Interagency Ecological Site Handbook for Rangelands. USDA Natural Resources Conservation Service, USDA Forest Service, USDI Bureau of Land Management. January 2013.

Land Resource Regions and Major Land Resource Areas of the United States, the Caribbean, and the Pacific Basin. USDA Handbook 296. USDA Natural Resources Conservation Service. 2006.

McNab, W.H., et al. 2007. Description of Ecological Sub-Regions: Sections of the Conterminous United States. USDA Forest Service. General Technical Report WO-76B.

National Cooperative Soil Survey. USDA Natural Resources Conservation Service.
<https://www.nrcs.usda.gov/wps/portal/nrcs/main/soils/survey/partnership/ncss/>.

National Ecological Site Handbook. USDA Natural Resources Conservation Service. March 2017.

National Range and Pasture Handbook. USDA Natural Resources Conservation Service. December 2003.

National Soil Information System. USDA Natural Resources Conservation Service.
https://www.nrcs.usda.gov/wps/portal/nrcs/detail/soils/survey/geo/?cid=nrcs142p2_053552.

National Soil Survey Handbook. USDA Natural Resources Conservation Service. November 2019.

National Water and Climate Center. USDA Natural Resources Conservation Service.
<https://www.wcc.nrcs.usda.gov/>.

NRCS Plants Database. USDA Natural Resources Conservation Service.
<https://plants.usda.gov/java/>.

Samuel, M.J., and R.H. Hart. 1994. Sixty-one years of secondary succession on rangelands of the Wyoming High Plains. *Journal of Range Management* 47:184-191.

Soil Survey Manual. USDA Natural Resources Conservation Service. March 2017.

Watts, M.J., and C.L. Wambolt. 1996. Long-term recovery of Wyoming big sagebrush after four treatments. Journal of Environmental Management 46:95-102.

Web Soil Survey. USDA Natural Resources Conservation Service.
<https://websoilsurvey.nrcs.usda.gov/app/HomePage.htm>.

Contributors

Jeff Fenton
Scott Brady
Maryjo Kimble

Approval

Kirt Walstad, 9/07/2023

Rangeland health reference sheet

Interpreting Indicators of Rangeland Health is a qualitative assessment protocol used to determine ecosystem condition based on benchmark characteristics described in the Reference Sheet. A suite of 17 (or more) indicators are typically considered in an assessment. The ecological site(s) representative of an assessment location must be known prior to applying the protocol and must be verified based on soils and climate. Current plant community cannot be used to identify the ecological site.

Author(s)/participant(s)	
Contact for lead author	
Date	05/04/2024
Approved by	Kirt Walstad
Approval date	
Composition (Indicators 10 and 12) based on	Annual Production

Indicators

1. **Number and extent of rills:**

2. **Presence of water flow patterns:**

3. **Number and height of erosional pedestals or terracettes:**

4. **Bare ground from Ecological Site Description or other studies (rock, litter, lichen, moss, plant canopy are not bare ground):**

5. **Number of gullies and erosion associated with gullies:**

6. **Extent of wind scoured, blowouts and/or depositional areas:**

7. **Amount of litter movement (describe size and distance expected to travel):**

8. **Soil surface (top few mm) resistance to erosion (stability values are averages - most sites will show a range of values):**

9. **Soil surface structure and SOM content (include type of structure and A-horizon color and thickness):**

10. **Effect of community phase composition (relative proportion of different functional groups) and spatial distribution on infiltration and runoff:**

11. **Presence and thickness of compaction layer (usually none; describe soil profile features which may be mistaken for compaction on this site):**

12. **Functional/Structural Groups (list in order of descending dominance by above-ground annual-production or live foliar cover using symbols: >>, >, = to indicate much greater than, greater than, and equal to):**

Dominant:

Sub-dominant:

Other:

Additional:

13. **Amount of plant mortality and decadence (include which functional groups are expected to show mortality or decadence):**

14. **Average percent litter cover (%) and depth (in):**

15. **Expected annual annual-production (this is TOTAL above-ground annual-production, not just forage annual-production):**

16. **Potential invasive (including noxious) species (native and non-native). List species which BOTH characterize degraded states and have the potential to become a dominant or co-dominant species on the ecological site if their future establishment and growth is not actively controlled by management interventions. Species that become dominant for only one to several years (e.g., short-term response to drought or wildfire) are not invasive plants. Note that unlike other indicators, we are describing what is NOT expected in the reference state**

for the ecological site:

17. **Perennial plant reproductive capability:**
