

Ecological site GX064X01X036 Loamy 17-20" PZ

Accessed: 06/30/2024

General information

Provisional. A provisional ecological site description has undergone quality control and quality assurance review. It contains a working state and transition model and enough information to identify the ecological site.

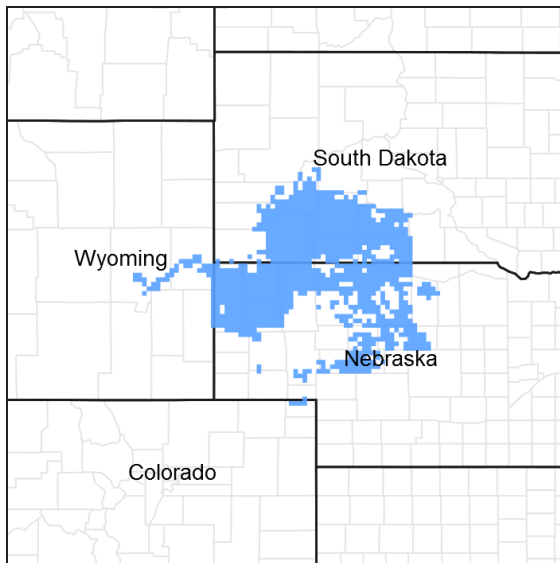

Figure 1. Mapped extent

Areas shown in blue indicate the maximum mapped extent of this ecological site. Other ecological sites likely occur within the highlighted areas. It is also possible for this ecological site to occur outside of highlighted areas if detailed soil survey has not been completed or recently updated.

Classification relationships

Level IV Ecoregions of the Conterminous United States: 25a – Pine Ridge Escarpment, 43h – White River Badlands, and 43i – Keya Paha Tablelands.

Associated sites

R064XY026NE	Loamy Overflow
R064XY032NE	Sandy 17-20" PZ
R064XY035NE	Clayey 17-20 PZ
R064XY037NE	Thin Upland
R064XY040NE	Shallow

Similar sites

R064XY037NE	Thin Upland [More little bluestem & sideoats grama; less western wheatgrass.]
R064XY035NE	Clayey 17-20 PZ [Green needlegrass dominant; needleandthread minor.]

R064XY026NE	Loamy Overflow [Less needleandthread; more big bluestem; more productive.]
-------------	--

Table 1. Dominant plant species

Tree	Not specified
Shrub	Not specified
Herbaceous	(1) <i>Pascopyrum smithii</i> (2) <i>Hesperostipa comata ssp. comata</i>

Legacy ID

R064XY036NE

Physiographic features

This site occurs on gently undulating to moderately steep rolling plains and low hills.

Table 2. Representative physiographic features

Landforms	(1) Alluvial fan (2) Plain (3) Hill
Flooding frequency	None
Ponding frequency	None
Elevation	2,900–4,000 ft
Slope	0–30%
Aspect	Aspect is not a significant factor

Climatic features

MLRA 64 is considered to have a continental climate – cold winters and hot summers, low humidity, light rainfall, and much sunshine. Extremes in temperature may also abound. The climate is the result of this MLRA's location near the geographic center of North America. There are few natural barriers on the northern Great Plains and air masses move freely across the plains and account for rapid changes in temperature.

Annual precipitation ranges from 17 to 20 inches per year. The normal average annual temperature is about 47° F. January is the coldest month with average temperatures ranging from about 21° F (Wood, SD) to about 25° F (Hemingford, NE). July is the warmest month with temperatures averaging from about 72° F (Hemingford, NE) to about 76° F (Wood, SD). The range of normal average monthly temperatures between the coldest and warmest months is about 55° F. This large annual range attests to the continental nature of this area's climate. Hourly winds are estimated to average about 11 miles per hour annually, ranging from about 13 miles per hour during the spring to about 10 miles per hour during the summer. Daytime winds are generally stronger than nighttime and occasional strong storms may bring brief periods of high winds with gusts to more than 50 miles per hour.

Growth of cool season plants begins in early to mid March, slowing or ceasing in late June. Warm season plants begin growth about mid May and continue to early or mid September. Green up of cool season plants may occur in September and October when adequate soil moisture is present.

Table 3. Representative climatic features

Frost-free period (average)	140 days
Freeze-free period (average)	162 days
Precipitation total (average)	19 in

Influencing water features

No riparian areas or wetland features are directly associated with this site.

Soil features

The features common to soils in this site are the very fine sandy loam to silt loam textured surface layers and slopes of 0 to 30 percent. The soils in this site are well to somewhat excessively drained and formed in soft siltstone, sandstone or alluvium. The surface layer is 4 to 15 inches thick. The texture of the subsurface layers ranges from loamy very fine sand to clay loam. The soils have a moderate infiltration rate. This site should show slight to no evidence of rills, wind scoured areas or pedestalled plants. Water flow paths are broken, irregular in appearance or discontinuous with numerous debris dams or vegetative barriers. The soil surface is stable and intact. Sub-surface soil layers are not restrictive to water movement and root penetration.

These soils are susceptible to wind and water erosion. The hazard of water erosion increases on slopes greater than about 15 percent. Loss of 50 percent or more of the surface layer of the soils on this site can result in a shift in species composition and/or production.

More information can be found in the various soil survey reports. Contact the local USDA Service Center for soil survey reports that include more detail specific to your location.

Table 4. Representative soil features

Surface texture	(1) Very fine sandy loam (2) Loam (3) Silt loam
Family particle size	(1) Loamy
Drainage class	Well drained to somewhat excessively drained
Permeability class	Moderately slow to moderate
Soil depth	20–80 in
Surface fragment cover ≤3"	0%
Surface fragment cover >3"	0%
Available water capacity (0-40in)	5–8 in
Calcium carbonate equivalent (0-40in)	0–15%
Electrical conductivity (0-40in)	0–4 mmhos/cm
Sodium adsorption ratio (0-40in)	0–5
Soil reaction (1:1 water) (0-40in)	6.1–9
Subsurface fragment volume ≤3" (Depth not specified)	0–30%
Subsurface fragment volume >3" (Depth not specified)	0–15%

Ecological dynamics

This site developed under Northern Great Plains climatic conditions, light to severe grazing by bison and other large herbivores, sporadic natural or man-caused wildfire (often of light intensities), and other biotic and abiotic factors that typically influence soil/site development. Changes will occur in the plant communities due to short-term weather variations, impacts of native and/or exotic plant and animal species, and management actions. While the following

plant community descriptions describe more typical transitions between communities that will occur, severe disturbances, such as periods of well-below average precipitation, can cause significant shifts in plant communities and/or species composition. Encroachment of ponderosa pine, Rocky Mountain juniper and eastern red cedar may occur from associated sites, and can shift site characteristics. These shifts can alter the site dynamics and potential. These species may occur in small amounts on several plant communities.

Continuous season-long grazing (during the typical growing season of May through October) and/or repeated seasonal grazing (e.g., every spring, every summer) without adequate recovery periods following each grazing occurrence causes this site to depart from the Western Wheatgrass/ Needleandthread Plant Community. Blue grama and buffalograss will increase and eventually develop into a sod. Western wheatgrass will increase initially and then begin to decrease. Needleandthread, green needlegrass, sideoats grama and big bluestem will decrease in frequency and production. Excessive defoliation can cause threeawns and annuals to increase and dominate the site. Extended periods of non-use and/or lack of fire or continuous seasonal grazing will result in a plant community dominated by cool season grasses such as western wheatgrass, bluegrass and annual brome.

Interpretations are primarily based on the Western Wheatgrass/Needleandthread Plant Community. It has been determined by study of rangeland relic areas, areas protected from excessive disturbance, and areas under long-term rotational grazing regimes. Trends in plant community dynamics ranging from heavily grazed to lightly grazed areas, seasonal use pastures, and historical accounts also have been used. Plant communities, states, transitional pathways, and thresholds have been determined through similar studies and experience.

The following is a diagram that illustrates the common plant communities that can occur on the site and the transition pathways between communities. The ecological processes will be discussed in more detail in the plant community descriptions following the diagram.

State and transition model

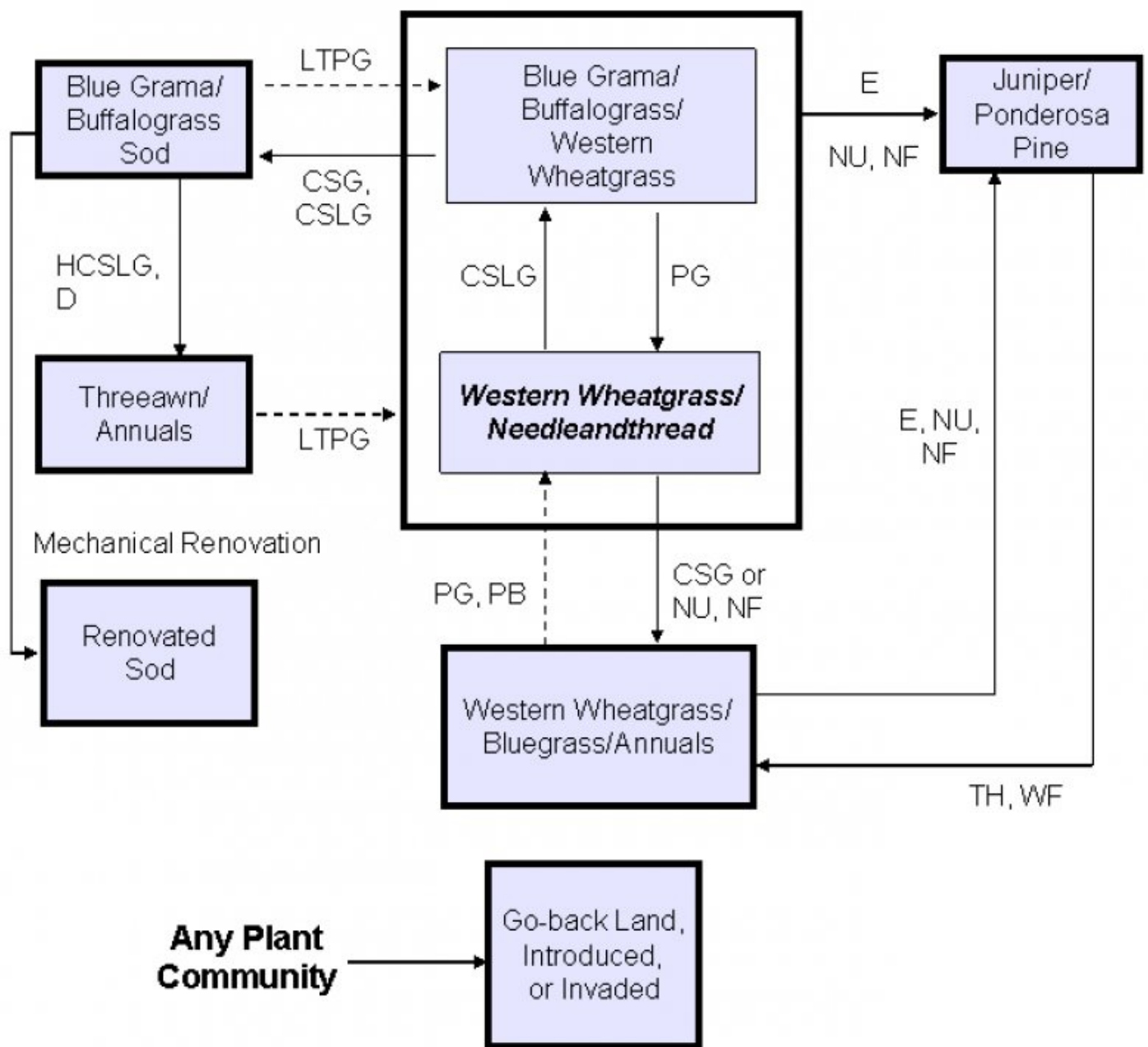

CSG - Continuous seasonal grazing (grazing a unit for an entire portion of a growing season, and the same season every year); **CSLG** - Continuous season-long grazing (grazing a unit for an entire growing season); **D** - Defoliation (rodents, insects, etc.); **E** - Encroachment or Escaped; **HCSLG** - Heavy continuous season-long grazing; **LTPG** - Long-term prescribed grazing; **NF** - No fire; **NU** - Non-use; **PB** - Prescribed burning; **PG** - Prescribed grazing (planned, controlled harvest of vegetation with grazing or browsing animals – see FOTG, Section IV, 528); **TH** - Timber harvest; **WF** - Wildfire.

State 1 Reference State

This state represents the natural range of variability that dominated the dynamics of this ecological site. This state was co-dominated by cool- and warm-season grasses. In pre-European times, the primary disturbance mechanisms for this site in the reference condition included frequent fire and grazing by large herding ungulates. Timing of fires and grazing coupled with weather events dictated the dynamics that occurred within the natural range of variability. Cool-season and taller warm-season grasses would have declined and a corresponding increase in short, warm-season grasses would have occurred. Today, a similar state can be found on areas that are properly managed with grazing and/or prescribed burning, and sometimes on areas receiving occasional short periods of rest.

Hydrological functions

Water is the principal factor limiting forage production on this site. This site is dominated by soils in hydrologic group B, with localized areas in hydrologic group C. Infiltration and runoff potential for this site varies from moderate to high depending on soil hydrologic group, slope and ground cover. In many cases, areas with greater than 75% ground cover have the greatest potential for high infiltration and lower runoff. An example of an exception would be where shortgrasses form a strong sod and dominate the site. Areas where ground cover is less than 50% have the greatest potential to have reduced infiltration and higher runoff (refer to Section 4, NRCS National Engineering Handbook for runoff quantities and hydrologic curves).

Recreational uses

This site provides hunting, hiking, photography, bird watching and other opportunities. The wide variety of plants that bloom from spring until fall have an esthetic value that appeals to visitors.

Wood products

Timber harvest of juniper and ponderosa pine may occur on localized areas of this site.

Other products

Seed harvest of native plant species can provide additional income on this site.

Other references

High Plains Regional Climate Center, University of Nebraska, 830728 Chase Hall, Lincoln, NE 68583-0728. (<http://hpccsun.unl.edu>)

USDA, NRCS. National Water and Climate Center, 101 SW Main, Suite 1600, Portland, OR 97204-3224. (<http://wcc.nrcs.usda.gov>)

USDA, NRCS. National Range and Pasture Handbook, September 1997

USDA, NRCS. National Soil Information System, Information Technology Center, 2150 Centre Avenue, Building A, Fort Collins, CO 80526. (<http://nasis.nrcs.usda.gov>)

USDA, NRCS. 2001. The PLANTS Database, Version 3.1 (<http://plants.usda.gov>). National Plant Data Center, Baton Rouge, LA 70874-4490 USA.

USDA, NRCS, Various Published Soil Surveys.

Contributors

SCB

Rangeland health reference sheet

Interpreting Indicators of Rangeland Health is a qualitative assessment protocol used to determine ecosystem condition based on benchmark characteristics described in the Reference Sheet. A suite of 17 (or more) indicators are typically considered in an assessment. The ecological site(s) representative of an assessment location must be

known prior to applying the protocol and must be verified based on soils and climate. Current plant community cannot be used to identify the ecological site.

Author(s)/participant(s)	Stan Boltz
Contact for lead author	Stan Boltz, stanley.boltz@sd.usda.gov, 605-352-1236
Date	07/09/2009
Approved by	Stan Boltz
Approval date	
Composition (Indicators 10 and 12) based on	Annual Production

Indicators

- 1. Number and extent of rills:** None.

- 2. Presence of water flow patterns:** None, or barely visible and discontinuous.

- 3. Number and height of erosional pedestals or terracettes:** None.

- 4. Bare ground from Ecological Site Description or other studies (rock, litter, lichen, moss, plant canopy are not bare ground):** 0 to 10 percent is typical.

- 5. Number of gullies and erosion associated with gullies:** None should be present.

- 6. Extent of wind scoured, blowouts and/or depositional areas:** None.

- 7. Amount of litter movement (describe size and distance expected to travel):** Litter should fall in place. Slight amount of movement of smallest size class litter is possible, but not normal.

- 8. Soil surface (top few mm) resistance to erosion (stability values are averages - most sites will show a range of values):** Soil aggregate stability ratings should typically be 5 to 6, normally 6. Surface organic matter adheres to the soil surface. Soil surface fragments will typically retain structure indefinitely when dipped in distilled water.

- 9. Soil surface structure and SOM content (include type of structure and A-horizon color and thickness):** A-horizon should be 4 to 15 inches thick with mollic (dark) colors when moist. Structure typically is medium to fine granular at least in the upper A-horizon.

- 10. Effect of community phase composition (relative proportion of different functional groups) and spatial distribution on infiltration and runoff:** Combination of shallow and deep rooted species (mid & tall rhizomatous and

tufted perennial cool-season grasses) with fine and coarse roots positively influences infiltration.

11. **Presence and thickness of compaction layer (usually none; describe soil profile features which may be mistaken for compaction on this site):** None – when dry, B horizons can be hard and appear to be compacted, but no platy structure will be present.
-

12. **Functional/Structural Groups (list in order of descending dominance by above-ground annual-production or live foliar cover using symbols: >>, >, = to indicate much greater than, greater than, and equal to):**

Dominant: Rhizomatous wheatgrasses > mid cool-season bunchgrasses >>

Sub-dominant: Mid warm-season grasses >

Other: Short cool-season grasses/grass-likes = short warm-season grasses > forbs > shrubs

Additional:

13. **Amount of plant mortality and decadence (include which functional groups are expected to show mortality or decadence):** Very little evidence of decadence or mortality. Bunch grasses have strong, healthy centers and shrubs are vigorous.
-

14. **Average percent litter cover (%) and depth (in):** Litter cover typically 50 to 70 percent, and litter depth about 0.25 inches.
-

15. **Expected annual annual-production (this is TOTAL above-ground annual-production, not just forage annual-production):** Total annual production ranges from 1,500 to 3,500 pounds/acre, with the reference value being 2,400 pounds/acre (air-dry basis).
-

16. **Potential invasive (including noxious) species (native and non-native). List species which BOTH characterize degraded states and have the potential to become a dominant or co-dominant species on the ecological site if their future establishment and growth is not actively controlled by management interventions. Species that become dominant for only one to several years (e.g., short-term response to drought or wildfire) are not invasive plants. Note that unlike other indicators, we are describing what is NOT expected in the reference state for the ecological site:** State and local noxious weeds, Kentucky bluegrass, smooth brome grass.
-

17. **Perennial plant reproductive capability:** All species exhibit high vigor relative to climatic conditions. Do not rate based solely on seed production. Perennial grasses should have vigorous rhizomes or tillers.
-