

# Ecological site R067AY152WY Sandy Lowland (SyL)

Last updated: 9/07/2023  
Accessed: 05/20/2024

## General information

**Provisional.** A provisional ecological site description has undergone quality control and quality assurance review. It contains a working state and transition model and enough information to identify the ecological site.

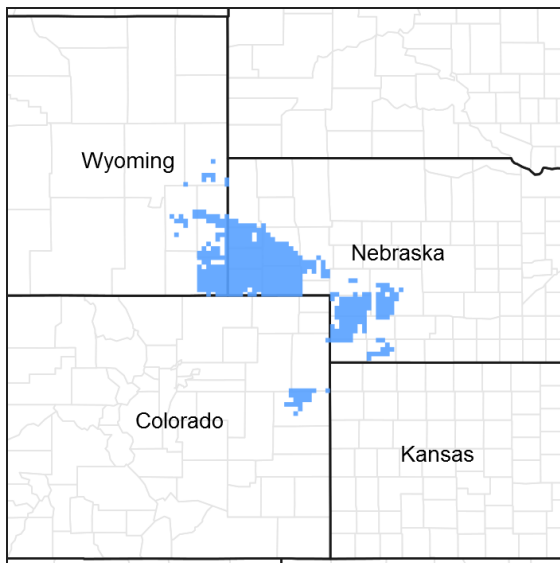

Figure 1. Mapped extent

Areas shown in blue indicate the maximum mapped extent of this ecological site. Other ecological sites likely occur within the highlighted areas. It is also possible for this ecological site to occur outside of highlighted areas if detailed soil survey has not been completed or recently updated.

## MLRA notes

Major Land Resource Area (MLRA): 067A–Central High Plains, Northern Part

MLRA 67A-Central High Plains, Northern Part is located in southeastern Wyoming (58 percent), the southwestern portion of the Nebraska panhandle (38 percent), and extreme northeastern Colorado (4 percent). It is comprised of rolling plains, upland breaks, and river valleys. The major rivers are the North Platte and Laramie. The headwaters of these systems are in the Rocky Mountains. Other tributaries include Crow, Horse, and Lodgepole Creeks. This MLRA is traversed by Interstate 25 and Interstate 80, and by U.S. Highways 26, 30 and 85. Major land uses include rangeland (71 percent), cropland (21 percent), pasture and hayland (1 percent), urban (3 percent), and miscellaneous (4 percent). Cities in this area include Cheyenne, Torrington, and Wheatland, WY; and Kimball, Oshkosh, and Scottsbluff, NE. Land ownership is mostly private. Areas of interest include Scotts Bluff National Monument, Chimney Rock and Fort Laramie National Historic Sites; Hawk Springs, Lake Minatare, and Wildcat Hills State Recreation Areas; Ash Hollow and Guernsey State Parks.

The elevations in MLRA 67A range from approximately 3,300 to 6,200 feet. The average annual precipitation in this area ranges from 13 to 17 inches per year, but may increase up to 18 inches per year, in localized areas. Precipitation occurs mostly during the growing season from rapidly developing thunderstorms. Mean annual air temperature ranges from 47 degrees Fahrenheit in the western part to 52 degrees Fahrenheit in the eastern part. Summer temperatures may exceed 100 degrees Fahrenheit. Winter temperatures may drop to sub-zero, and snowfall varies from 20 to 50 inches per year.

## Classification relationships

MLRA 67A is in the Western Great Plains Range and Irrigation Land Resource Region. It is in the High Plains Section, of the Great Plains Province, of the Interior Plains (USDA, 2006). MLRAs can be defined by climate, landscapes, geology, and annual precipitation zones (PZ). Other features such as landforms, soil properties, and key vegetation further refine these concepts, and are described at the Ecological Site Description (ESD) level.

### Revision Notes:

The Sandy Lowland (SyL) Ecological Site was developed by an earlier version of the Sandy Lowland (SyL) ESD (2005, updated 2008). The earlier version of the Sandy Lowland ESD (previously called Sandy Lowland (SyL) 12-17 inch Precipitation Zone ESD) was based on input from NRCS (formerly Soil Conservation Service) and historical information obtained from the Sandy Lowland (SyL) Range Site Description (1988) and earlier (1970). This ESD meets the Provisional requirements of the National Ecological Site Handbook (NESH). This ESD will continue refinement towards an Approved status according to the NESH.

## Ecological site concept

The Sandy Lowland site is a run-on site that is not saline or alkaline. The water table is deeper than 36 inches, but is shallow enough to be available to deep-rooted woody plants. The surface soil textures have a strong sand component.

## Associated sites

R067AY150WY	<b>Sandy (Sy)</b> This ecological site is commonly adjacent.
-------------	---

## Similar sites

R067AY124WY	<b>Loamy Lowland (LyL)</b> Loamy Lowland Ecological Site has loamy soil textures.
-------------	--

Table 1. Dominant plant species

Tree	(1) <i>Populus deltoides ssp. monilifera</i>
Shrub	(1) <i>Artemisia cana</i> (2) <i>Artemisia filifolia</i>
Herbaceous	(1) <i>Hesperostipa comata</i> (2) <i>Schizachyrium scoparium</i>

## Physiographic features

This site typically occurs on the floodplains or floodplain-steps between the channel and the higher stream terraces of the river valleys. It may also occur on drainageways that are subject to extra moisture or runoff from the surrounding slopes during rain events.

Table 2. Representative physiographic features

Landforms	(1) Flood plain (2) Flood-plain step (3) Drainageway
Runoff class	Negligible to very low
Flooding duration	Very brief (4 to 48 hours) to brief (2 to 7 days)
Flooding frequency	Rare to occasional
Ponding frequency	None
Elevation	914–1,676 m

Slope	0–3%
Water table depth	203–610 cm
Aspect	Aspect is not a significant factor

## Climatic features

Wide fluctuations in precipitation may occur from year to year, as well as occasional periods of drought (longer than one year in duration). Two-thirds of the annual precipitation occurs during the growing season from April to September. The mean annual air temperature (MAAT) ranges from 47 degrees Fahrenheit in the western part to 52 degrees Fahrenheit in the eastern part. Cold air outbreaks from Canada in winter move rapidly from northwest to southeast and account for extreme minimum temperatures. Chinook winds may also occur in winter and bring rapid rises in temperature. Extreme storms may occur during the winter, but most severely affect ranch operations during the late winter and spring months. High-intensity afternoon thunderstorms may arise in summer. Wind speed averages about 8 miles per hour, ranging from 10 during the spring to 7 during late summer. Daytime winds are generally stronger than nighttime and occasional strong storms may bring brief periods of high winds with gusts to more than 75 mph. The average length of the freeze-free period (28 degrees Fahrenheit) is 150 days from May 4 to October 1. The average frost-free period (32 degrees Fahrenheit) is 128 days from May 16 to September 21. Growing season increases from west to east (Wyoming to Nebraska). Growth of native cool-season plants begins about April 1 and continues to mid-June. Native warm-season plants begin growth about May 15 and continue to about August 15. Regrowth of cool-season plants occur in September in most years, depending upon moisture.

**Table 3. Representative climatic features**

Frost-free period (characteristic range)	85-117 days
Freeze-free period (characteristic range)	119-135 days
Precipitation total (characteristic range)	406-432 mm
Frost-free period (actual range)	84-123 days
Freeze-free period (actual range)	116-137 days
Precipitation total (actual range)	356-457 mm
Frost-free period (average)	103 days
Freeze-free period (average)	128 days
Precipitation total (average)	406 mm

## Climate stations used

- (1) HARRISBURG 12WNW [USC00253605], Harrisburg, NE
- (2) CHUGWATER [USC00481730], Chugwater, WY
- (3) PHILLIPS [USC00487200], LaGrange, WY
- (4) WHEATLAND 4 N [USC00489615], Wheatland, WY
- (5) CHEYENNE [USW00024018], Cheyenne, WY
- (6) OLD FT LARAMIE [USC00486852], Yoder, WY
- (7) OSHKOSH [USC00256385], Oshkosh, NE
- (8) KIMBALL 2NE [USC00254440], Kimball, NE
- (9) SCOTTSBLUFF HEILIG AP [USW00024028], Scottsbluff, NE
- (10) BRIDGEPORT [USC00251145], Bridgeport, NE

## Influencing water features

There are no water features associated with the ecological site or adjacent wetland or riparian regimes that influence the vegetation and/or management of the site. A few map units in this ESD have a 1 percent to 10 percent hydric component for draws, drainageways, or swales that have a water table.

## Soil features

The soils on this site are typically very deep, well to excessively drained, that formed from alluvium. They typically have moderately rapid to very rapid permeability. The available water capacity is very low to low. Available water is the portion of water in a soil that can be readily absorbed by plant roots. The soil moisture regime is typically aridic ustic. The soil temperature regime is mesic.

The surface layer of the soils in this site are typically loamy fine sand, loamy sand, or fine sandy loam, but may include sand. The surface layer ranges from a depth of 3 to 8 inches thick. The subsoil is typically fine sand, fine sandy loam, or loamy fine sand, but may include gravelly coarse sand, loamy sand, sand, or stratified layers of varying textures. Rock fragments range from 0 to 45 percent in the underlying material but are typically less than 15 percent. Soils in this site have carbonates at the surface or can be leached to 8 inches; some soils may be leached to 80 inches or more. These soils are very susceptible to erosion by water and wind if not covered. The potential for erosion increases where vegetative cover is inadequate. Channel cutting, deposition, and removals may occur adjacent to rivers or streams.

The surface soil structure is typically granular or single grain, and structure below the surface is single grain, but may include massive or weak subangular blocky. Soil structure describes the manner in which soil particles are aggregated and defines the nature of the system of pores and channels in a soil.

Major soil series correlated to this ecological site include: Bankard, Broadwater, Glenberg, and Lemoyne.

Other soil series that have been correlated to this site include: Ustic Torrfluvents.

The attributes listed below represent 0-40 inches in depth or to the first restrictive layer.

Note: Revisions to soil surveys are on-going. For the most recent updates, visit the Web Soil Survey, the official site for soils information: <http://websoilsurvey.nrcs.usda.gov/app/WebSoilSurvey.aspx>.

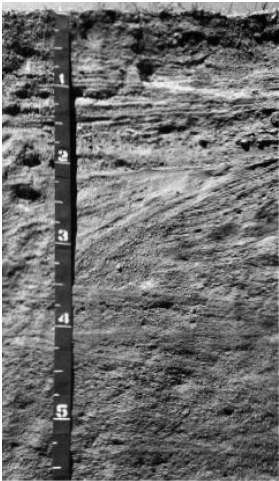

Figure 8. Sandy Lowland Soil Profile Picture Broadwater series, Garden County, NE

Table 4. Representative soil features

Parent material	(1) Alluvium
Surface texture	(1) Loamy fine sand (2) Loamy sand (3) Fine sandy loam
Drainage class	Well drained to excessively drained
Permeability class	Moderately rapid to very rapid
Soil depth	203 cm
Surface fragment cover <=3"	0%

Surface fragment cover >3"	0%
Available water capacity (0-101.6cm)	3.81–15.24 cm
Calcium carbonate equivalent (0-101.6cm)	0–10%
Electrical conductivity (0-101.6cm)	0–2 mmhos/cm
Sodium adsorption ratio (0-101.6cm)	0
Soil reaction (1:1 water) (0-101.6cm)	6.6–8.4
Subsurface fragment volume <=3" (Depth not specified)	0–45%
Subsurface fragment volume >3" (Depth not specified)	0%

## Ecological dynamics

The information in this ESD, including the state-and-transition model diagram (STM), was developed using archeological and historical data, professional experience, and scientific studies. The information is representative of a dynamic set of plant communities that represent the complex interaction of several ecological processes. The plant composition has been determined by study of rangeland relic areas, areas protected from excessive disturbance, seasonal use pastures, short duration/time controlled grazing strategies, and historical accounts.

The Sandy Lowland ecological site is characterized by three states: Reference, Sod-bound with Decadent Cottonwoods, and Increased *Bare Ground*. The Reference State is characterized by cool- and warm-season bunch midgrasses (needle and thread and little bluestem), and warm-season bunch tallgrasses (prairie sandreed and sand bluestem). Secondary grasses include streambank wheatgrass, (also known as thickspike wheatgrass), western wheatgrass, blue grama, and switchgrass. A minor component of forbs and shrubs (Woods rose, western snowberry, western sandcherry, and silver sagebrush) are also present, with an overstory of plains cottonwood and other trees. See the species composition list below. The Sod-bound State is characterized by warm-season shortgrass (blue grama), and stoloniferous grass (buffalograss), and grasslikes (threadleaf sedge). The Increased *Bare Ground* State is characterized by remnant blue grama, buffalograss, and threadleaf sedge. Warm-season bunchgrass (Fendler threeawn), annual grass (sixweeks fescue), and forbs such as hairy false goldenaster and curlycup gumweed. Shrubs such as fringed sagewort and pricklypear have increased. Annual invasive species include burningbush, Russian thistle, and cheatgrass. Perennial invasive species include Kentucky bluegrass and smooth brome. Other noxious weeds that may invade include Canada thistle, houndstongue, whitetop (also known as hoary cress), and leafy spurge. Introduced trees such as Russian olive may invade, and eventually dominate the site.

As this site begins to deteriorate from a combination of frequent and severe grazing during the growing season, bunchgrasses such as needle and thread, and little- and sand bluestem decrease in both frequency and production. Blue grama increases. Under continued frequent and severe defoliation with no rest periods, rhizomatous wheatgrasses also decreases. Key shrubs such as Woods' rose and western sandcherry, and other palatable forbs such as American vetch also decrease. If continued, the plant community becomes sod-bound, and all mid-grasses can eventually be removed from the plant community. Over the long-term, this continuous use in combination with high stock densities results in a broken sod with areas of bare ground developing and species such as cheatgrass, smooth brome, and Kentucky bluegrass invading.

The degree of grazing has a significant impact on the ecological dynamics of the site. This region was historically occupied by large grazing animals, such as bison, elk, pronghorn, and mule deer. Grazing by these large herbivores, along with climatic and seasonal weather fluctuations, had a major influence on the ecological dynamics of the site. Deer and pronghorn are widely distributed throughout the MLRA. Secondary influences of herbivory by species such as prairie dogs and other small rodents, insects, and root-feeding organisms continues to impact the vegetation.

Historically, grazing patterns by herds of large ungulates were driven by water distribution, precipitation events, drought events, and fire. It is believed that grazing periods would have been shorter, followed by longer recovery periods. These large migrating herds impacted the ecological processes of nutrient and hydrologic cycles, by urination, trampling (incorporation of litter into the soil surface), and breaking of surface crust, (which increases water infiltration).

Today, livestock grazing, especially beef cattle has been a major influence on the ecological dynamics of the site. Grazing management, coupled with the effects of annual climatic variations, largely dictates the plant communities for the site.

Recurrent drought has historically impacted the vegetation of this region. Changes in species composition vary depending upon the duration and severity of the drought cycle and prior grazing management. Drought events since 2002 have significantly increased mortality of blue grama and buffalograss in some locales.

This site developed with occasional fire as part of the ecological processes. Historic fire frequency (pre-industrial) is estimated at 10 to 14 years (Guyette, 2012), randomly distributed, and started by lightning at various times throughout the growing season. Early human inhabitants also were likely to start fires for various reasons (deliberate or accidental). It is believed that fires were set as a management tool for attracting herds of large migratory herbivores (Stewart, 2002). The impact of fire over the past 100 years has been relatively insignificant due to the human control of wildfires and the lack of acceptance of prescribed fire as a management tool.

## State and transition model

### Ecosystem states

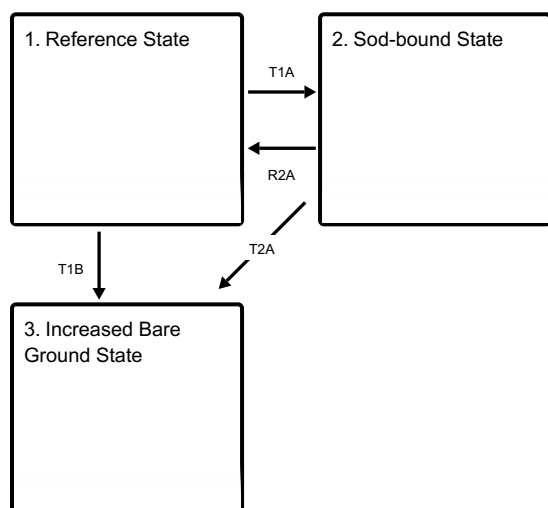

**T1A** - Excessive grazing. Lack of fire.

**T1B** - Excessive grazing. Lack of fire.

**R2A** - Flooding. Prescribed grazing.

**T2A** - Excessive grazing. Lack of fire.

### State 1 submodel, plant communities

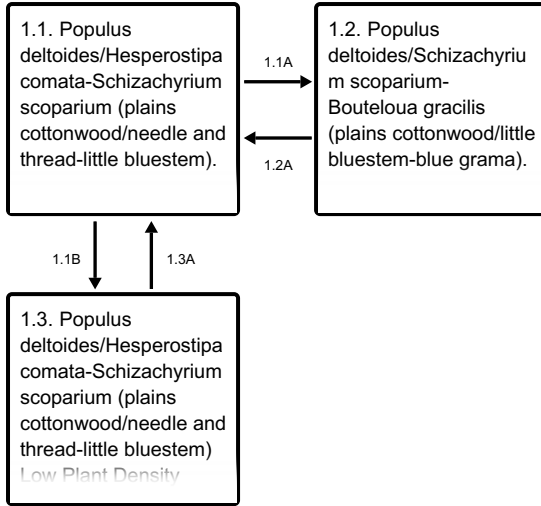

**1.1A** - Excessive grazing. Lack of fire.

**1.1B** - Non-use. Lack of fire.

**1.2A** - Prescribed grazing. Prescribed fire.

**1.3A** - Prescribed grazing. Prescribed fire.

### State 2 submodel, plant communities

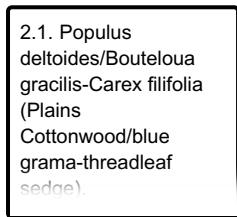

### State 3 submodel, plant communities

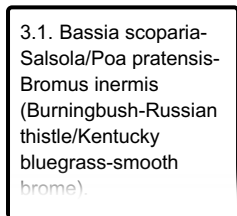

## State 1 Reference State

The Reference State is characterized by three distinct plant community phases. The plant communities, and the various successional stages between them, represent the natural range of variability within the Reference State.

### Dominant plant species

- plains cottonwood (*Populus deltoides* ssp. *monilifera*), tree
- silver sagebrush (*Artemisia cana*), shrub
- sand sagebrush (*Artemisia filifolia*), shrub
- western sandcherry (*Prunus pumila* var. *besseyi*), shrub
- needle and thread (*Hesperostipa comata*), grass
- little bluestem (*Schizachyrium scoparium*), grass

### Community 1.1

#### **Populus deltoides/Hesperostipa comata-Schizachyrium scoparium (plains cottonwood/needle and thread-little bluestem).**

This is the interpretive plant community for the Sandy Lowland Ecological Site. This community developed with

grazing by large herbivores and is suited to grazing by domestic livestock. Historically, fires likely occurred infrequently, and were randomly distributed. This plant community can be found on areas where grazed plants receive adequate periods of recovery during the growing season. The potential vegetation is about 65 to 85 percent grasses and grass-likes, 5 to 10 percent forbs, and 5 to 10 percent woody plants. Trees can make up 5 to 15 percent of the total annual production, and approximately 10 to 30 percent canopy. The major grasses include needle and thread, prairie sandreed, little bluestem, and sand bluestem. Various species of shrubs and trees typically occur due to the water table within reach of the woody plants. These can include shrubs such as Woods' rose, western snowberry, western sandcherry, and silver sagebrush (in Wyoming). A diverse age-class of plains cottonwood, and other trees including boxelder and green ash are found. In addition, numerous other species of grasses can occur, along with a wide variety of forbs. The forbs present include prairie coneflower, lemon scurfpea, larkspur, penstemon, and American vetch. Because of the landscape position and micro-climate produced by the overstory of trees, plant diversity is very high. The total annual production (air-dry weight) is about 2,500 pounds per acre during an average year, but ranges from about 2,000 pounds per acre in unfavorable years to about 3,000 pounds per acre in above-average years. Community dynamics (nutrient and water cycles, and energy flow) are functioning properly, infiltration rates are moderate, and soil erosion is low. Litter is properly distributed where vegetative cover is continuous. Decadence and natural plant mortality are low. This community is resistant to many disturbances except heavy, continuous grazing, tillage, and development into urban or other uses.

### Dominant plant species

- plains cottonwood (*Populus deltoides ssp. monilifera*), tree
- silver sagebrush (*Artemisia cana*), shrub
- sand sagebrush (*Artemisia filifolia*), shrub
- western sandcherry (*Prunus pumila var. besseyi*), shrub
- needle and thread (*Hesperostipa comata*), grass
- little bluestem (*Schizachyrium scoparium*), grass

Figure 10. Plant community growth curve (percent production by month). WY1105, 12-14SP Extra water w/warm - LL, Ov, CyO, SL. 12-14" Precipitation Zone, Southern Plains (SP), with warm-season (grasses); sites which receive additional water (run-on position, from adjacent sites)..

Jan	Feb	Mar	Apr	May	Jun	Jul	Aug	Sep	Oct	Nov	Dec
0	0	0	5	20	25	30	15	5	0	0	0

### Community 1.2

#### **Populus deltoides/Schizachyrium scoparium-Bouteloua gracilis (plains cottonwood/little bluestem-blue grama).**

Western wheatgrass, needle and thread, and the bluestems have been reduced and may be missing from the plant community. Grazing-tolerant species such as blue grama and threadleaf sedge have increased. Prairie clover species, American vetch, and other palatable forbs such as dotted gayfeather and penstemon are present in reduced amounts. Hairy false goldenaster, scarlet globemallow, Cuman ragweed, and plains pricklypear have increased. Palatable shrubs and trees are heavily browsed, often having a hedged appearance. New tree seedlings are reduced or absent. Plant diversity is moderate. The total annual production (air-dry weight) is about 1,750 pounds per acre during an average year, but ranges from about 1,400 pounds per acre in unfavorable years to about 2,100 pounds per acre in above-average years. Total aboveground biomass has been reduced. Reduction of rhizomatous wheatgrasses, nitrogen-fixing forbs, and the reduction of palatable shrubs and seedling trees have begun to alter the biotic integrity of this community. Water and nutrient cycles may be impaired. Nearly all plant species typically found in the Reference Plant Community are present and will respond to changes in grazing management.

### Dominant plant species

- plains cottonwood (*Populus deltoides ssp. monilifera*), tree
- silver sagebrush (*Artemisia cana*), shrub
- sand sagebrush (*Artemisia filifolia*), shrub
- western sandcherry (*Prunus pumila var. besseyi*), shrub
- little bluestem (*Schizachyrium scoparium*), grass
- blue grama (*Bouteloua gracilis*), grass



Figure 11. Plant community growth curve (percent production by month). WY1105, 12-14SP Extra water w/warm - LL, Ov, CyO, SL. 12-14" Precipitation Zone, Southern Plains (SP), with warm-season (grasses); sites which receive additional water (run-on position, from adjacent sites)..

Jan	Feb	Mar	Apr	May	Jun	Jul	Aug	Sep	Oct	Nov	Dec
0	0	0	5	20	25	30	15	5	0	0	0

### Community 1.3

#### **Populus deltoides/Hesperostipa comata-Schizachyrium scoparium (plains cottonwood/needle and thread-little bluestem) Low Plant Density Community.**

This plant community developed under many years of non-use and lack of fire. Plant species resemble the Reference Plant Community however, frequency and production are reduced. Eventually, litter levels can become high enough to cause decadence and mortality of the stand. Bunchgrasses typically develop dead centers and rhizomatous grasses can form small decadent communities due to a lack of impact by grazing animals. Much of the available nutrients are tied up in standing dead plant material and increased amounts of litter. The semiarid environment and the absence of animal traffic to break down litter slows nutrient recycling. Cool-season grasses and pricklypear have typically increased. Blue grama is reduced. Noxious weeds such as Canada and musk thistle, and whitetop may invade if a seed source is readily available. Invasive grasses such as cheatgrass and smooth brome tend to encroach under these conditions. Water flow patterns and pedestalling can become apparent. Infiltration is reduced and runoff is increased. In advanced states of non-use or lack of fire, bare areas increase causing an erosion concern. The total annual production (air-dry weight) can vary from 100 to 1,500 pounds per acre depending on weather conditions and the plants that are present. The introduction of grazing or fire quickly changes the plant community. It is more vulnerable to severe disturbance than the Reference Plant Community. Soil erosion accelerates if bare ground increases. Infiltration is reduced and runoff is increased.

#### **Dominant plant species**

- plains cottonwood (*Populus deltoides ssp. monilifera*), tree
- silver sagebrush (*Artemisia cana*), shrub
- sand sagebrush (*Artemisia filifolia*), shrub
- western sandcherry (*Prunus pumila var. besseyi*), shrub
- needle and thread (*Hesperostipa comata*), grass
- blue grama (*Bouteloua gracilis*), grass

Figure 12. Plant community growth curve (percent production by month). WY1105, 12-14SP Extra water w/warm - LL, Ov, CyO, SL. 12-14" Precipitation Zone, Southern Plains (SP), with warm-season (grasses); sites which receive additional water (run-on position, from adjacent sites)..

Jan	Feb	Mar	Apr	May	Jun	Jul	Aug	Sep	Oct	Nov	Dec
0	0	0	5	20	25	30	15	5	0	0	0

### Pathway 1.1A

#### **Community 1.1 to 1.2**

Frequent and severe defoliation without adequate recovery between grazing events and lack of fire shifts this plant community toward the 1.2 Community. Drought accelerates this process. Biotic integrity, water, and nutrient cycles may become impaired as a result of this community pathway.

### Pathway 1.1B

#### **Community 1.1 to 1.3**

Non-use and lack of fire cause the Reference Plant Community to shift toward the 1.3 Community. Plant decadence and standing dead plant material impede energy flow. Initially, excess litter increases. Eventually, native plant density begins to decrease and annuals and introduced species may begin to invade.

## Pathway 1.2A

### Community 1.2 to 1.1

Grazing that allows for adequate recovery between grazing events, proper stocking rates, and prescribed fire shift this Community back toward the Reference Plant Community.

#### Conservation practices

Prescribed Burning
Prescribed Grazing

## Pathway 1.3A

### Community 1.3 to 1.1

The return of grazing with adequate recovery and normal fire frequency shifts this plant community toward the Reference Plant Community. This change can occur in a relatively short time frame with the return of these disturbances.

#### Conservation practices

Prescribed Burning
Prescribed Grazing

## State 2

### Sod-bound State

An ecological threshold has been crossed and a significant amount of production and diversity has been lost when compared to the Reference State. Significant biotic and soil changes have negatively impacted energy flow, and nutrient and hydrologic cycles. This is a very stable state, resistant to change due to the high tolerance of blue grama to grazing, the development of a shallow root system (root pan), and subsequent changes in hydrology and nutrient cycling. The loss of other functional/structural groups such as cool-season bunch and rhizomatous grasses, forbs, and shrubs, and loss of cottonwood seedling recruitment reduces the biodiversity productivity of this state.

#### Dominant plant species

- plains cottonwood (*Populus deltoides* ssp. *monilifera*), tree
- silver sagebrush (*Artemisia cana*), shrub
- sand sagebrush (*Artemisia filifolia*), shrub
- western sandcherry (*Prunus pumila* var. *besseyi*), shrub
- blue grama (*Bouteloua gracilis*), grass
- threadleaf sedge (*Carex filifolia*), grass
- buffalograss (*Bouteloua dactyloides*), grass

## Community 2.1

### **Populus deltoides/Bouteloua gracilis-Carex filifolia (Plains Cottonwood/blue grama-threadleaf sedge).**

The mid- and tallgrasses, and palatable forbs have been eliminated. The dominant species are blue grama, threadleaf sedge, and buffalograss. These species have developed into a sod-bound condition occurring in localized colonies exhibiting a mosaic appearance. Fendler threeawn has increased. Forbs and shrubs that continue to increase are Cuman ragweed (also known as western ragweed), hairy false goldenaster, scarlet globemallow, pricklypear, green- and fringed sagewort. Kentucky bluegrass and smooth brome can invade and become dominant and contribute to the sod-bound condition. No new tree seedlings occur. Only cottonwoods that have reached "escape height" (out of reach of the browsers) remain, creating a single-age class that becomes decadent and begins to die off. Plant diversity is very low. Energy flow, water cycle, and mineral cycle have been negatively affected. Litter levels are very low and unevenly distributed. The total annual production (air-dry weight) is about 1,250 pounds per acre during an average year, but ranges from about 900 pounds per acre in unfavorable years to

about 1,400 pounds per acre in above-average years.

**Dominant plant species**

- plains cottonwood (*Populus deltoides ssp. monilifera*), tree
- silver sagebrush (*Artemisia cana*), shrub
- sand sagebrush (*Artemisia filifolia*), shrub
- western sandcherry (*Prunus pumila var. besseyi*), shrub
- blue grama (*Bouteloua gracilis*), grass
- threadleaf sedge (*Carex filifolia*), grass
- buffalograss (*Bouteloua dactyloides*), grass

Figure 13. Plant community growth curve (percent production by month). WY1105, 12-14SP Extra water w/warm - LL, Ov, CyO, SL. 12-14" Precipitation Zone, Southern Plains (SP), with warm-season (grasses); sites which receive additional water (run-on position, from adjacent sites)..

Jan	Feb	Mar	Apr	May	Jun	Jul	Aug	Sep	Oct	Nov	Dec
0	0	0	5	20	25	30	15	5	0	0	0

**State 3**

**Increased Bare Ground State**

An ecological threshold has been crossed. The Increased *Bare Ground* State denotes changes in infiltration, runoff, aggregate stability, and species composition. The changes in water movement and the plant community affect changes in hydrologic functionality, biotic integrity, and soil and site stability. Infiltration, runoff, and soil erosion vary depending on the vegetation present. Erosion and loss of organic matter and carbon reserves are concerns.

**Dominant plant species**

- plains cottonwood (*Populus deltoides ssp. monilifera*), tree
- silver sagebrush (*Artemisia cana*), shrub
- sand sagebrush (*Artemisia filifolia*), shrub
- Kentucky bluegrass (*Poa pratensis*), grass
- smooth brome (*Bromus inermis*), grass
- burningbush (*Bassia scoparia*), other herbaceous
- Russian thistle (*Salsola*), other herbaceous

**Community 3.1**

**Bassia scoparia-Salsola/Poa pratensis-Bromus inermis (Burningbush-Russian thistle/Kentucky bluegrass-smooth brome).**

The plant composition is made up introduced grasses, annuals, noxious weeds, and a few species of native forbs and grasses that are very tolerant to frequent and severe defoliation. The site may also be invaded with introduced trees. The dominant grasses typically include Kentucky bluegrass, smooth brome, Fendler threeawn, sand dropseed, and sandhills muhly. Annual grasses such as cheatgrass and sixweeks fescue have increased or invaded. The dominant perennial forbs include lemon scurfpea, curlycup gumweed, and hairy false goldenaster. Other forbs that increase or invade the site include annual sunflower, annual and spreading buckwheat, burningbush, Russian thistle, and pigweed. Shrubs may include pricklypear and sand sagebrush. Noxious weeds such as whitetop, Canada and musk thistle, and hound’s tongue may have invaded the site. Decadence and mortality of remaining trees increases. Introduced trees, such as Russian olive and tamarisk may invade and eventually dominate the site. This plant community is highly variable in both species composition and production. Average annual production must be determined on site. This plant community is very resistant to change because of the lack of native species and the amount of introduced plants and weeds present. Smooth brome and Kentucky bluegrass can eventually dominate the site due to their rhizomatous growth form and their resistance to heavy grazing. Once this occurs, it is nearly impossible to change the plant composition in a reasonable management timeframe. Litter levels are extremely low due to reduced production. The changes in water movement and the plant community affect changes in hydrologic functionality, biotic integrity, and soil and site stability. Infiltration, runoff and soil erosion vary depending on the vegetation present.

**Dominant plant species**

- plains cottonwood (*Populus deltoides ssp. monilifera*), tree
- silver sagebrush (*Artemisia cana*), shrub
- sand sagebrush (*Artemisia filifolia*), shrub
- plains pricklypear (*Opuntia polyacantha*), shrub
- Kentucky bluegrass (*Poa pratensis*), grass
- smooth brome (*Bromus inermis*), grass
- sand dropseed (*Sporobolus cryptandrus*), grass
- Fendler threeawn (*Aristida purpurea var. longiseta*), grass
- burningbush (*Bassia scoparia*), other herbaceous
- Russian thistle (*Salsola*), other herbaceous

Figure 14. Plant community growth curve (percent production by month). WY1102, 12-14SP Extra water w/o warm - LL, Ov, CyO, SL. 12-14" Precipitation Zone, Southern Plains (SP), without warm-season (grasses); sites which receive additional water (run-on position), from adjacent sites..

Jan	Feb	Mar	Apr	May	Jun	Jul	Aug	Sep	Oct	Nov	Dec
0	0	0	5	25	30	20	15	5	0	0	0

**Transition T1A**

**State 1 to 2**

Frequent and severe defoliation without adequate recovery periods between grazing events and lack of fire shifts this plant community across an ecological threshold toward the Sod-bound State. Biotic integrity and hydrologic function are impaired as a result of this transition.

**Transition T1B**

**State 1 to 3**

Long-term, heavy, continuous grazing without adequate recovery periods and lack of fire shift this plant community across an ecological threshold toward the Increased *Bare Ground* State. Erosion and loss of organic matter and carbon reserves are concerns. Non-native exotic plants are likely to invade.

**Restoration pathway R2A**

**State 2 to 1**

Flooding followed by very long-term prescribed grazing moves this state towards the Reference State. A timely flood event can result in germination of cottonwood seeds. Cottonwood regeneration is feasible if grazing and degree of browsing is closely monitored and controlled. Prescribed fire enhances the herbaceous component of the stand, but potentially eliminates the cottonwood regeneration.

**Conservation practices**

Prescribed Grazing

**Transition T2A**

**State 2 to 3**

Long-term frequent and severe defoliation without adequate recovery between grazing events and lack of fire cause a shift across an ecological threshold to the Increase *Bare Ground* State. Erosion and loss of organic matter along with invasion of introduced plants and noxious weeds are constraints to recovery.

**Additional community tables**

Table 5. Community 1.1 plant community composition

Group	Common Name	Symbol	Scientific Name	Annual Production (Kg/Hectare)	Foliar Cover (%)
-------	-------------	--------	-----------------	--------------------------------	------------------

Grass/Grasslike					
1	<b>Tall warm-season grasses</b>			420–1261	
	prairie sandreed	CALO	<i>Calamovilfa longifolia</i>	140–981	–
	sand bluestem	ANHA	<i>Andropogon hallii</i>	140–841	–
	little bluestem	SCSCS	<i>Schizachyrium scoparium</i> var. <i>scoparium</i>	280–841	–
	switchgrass	PAVI2	<i>Panicum virgatum</i>	0–280	–
2	<b>Cool-season bunchgrass</b>			420–1121	
	needle and thread	HECO26	<i>Hesperostipa comata</i>	420–1121	–
	prairie Junegrass	KOMA	<i>Koeleria macrantha</i>	0–140	–
	Indian ricegrass	ACHY	<i>Achnatherum hymenoides</i>	0–140	–
3	<b>Cool-season rhizomatous grass</b>			140–280	
	thickspike wheatgrass	ELLAL	<i>Elymus lanceolatus</i> ssp. <i>lanceolatus</i>	140–280	–
	western wheatgrass	PASM	<i>Pascopyrum smithii</i>	140–280	–
4	<b>Warm-season shortgrass</b>			140–280	
	blue grama	BOGR2	<i>Bouteloua gracilis</i>	140–280	–
5	<b>Other grass/grasslikes</b>			280–701	
	threadleaf sedge	CAFI	<i>Carex filifolia</i>	0–280	–
	sedge	CAREX	<i>Carex</i>	0–140	–
	Graminoid (grass or grass-like)	2GRAM	<i>Graminoid (grass or grass-like)</i>	0–140	–
	Sandberg bluegrass	POSE	<i>Poa secunda</i>	0–140	–
	sand dropseed	SPCR	<i>Sporobolus cryptandrus</i>	0–140	–
Forb					
6	<b>Forbs</b>			140–280	
	Cuman ragweed	AMPS	<i>Ambrosia psilostachya</i>	0–56	–
	pussytoes	ANTEN	<i>Antennaria</i>	0–56	–
	prairie sagewort	ARFR4	<i>Artemisia frigida</i>	0–56	–
	white sagebrush	ARLU	<i>Artemisia ludoviciana</i>	0–56	–
	milkvetch	ASTRA	<i>Astragalus</i>	0–56	–
	false boneset	BREUC	<i>Brickellia eupatorioides</i> var. <i>corymbulosa</i>	0–56	–
	prairie clover	DALEA	<i>Dalea</i>	0–56	–
	larkspur	DELPH	<i>Delphinium</i>	0–56	–
	hairy false goldenaster	HEVI4	<i>Heterotheca villosa</i>	0–56	–
	dotted blazing star	LIPU	<i>Liatris punctata</i>	0–56	–
	evening primrose	OENOT	<i>Oenothera</i>	0–56	–
	beardtongue	PENST	<i>Penstemon</i>	0–56	–
	scurfpea	PSORA2	<i>Psoraleidium</i>	0–56	–
	upright prairie coneflower	RACO3	<i>Ratibida columnifera</i>	0–56	–
	ragwort	SENEC	<i>Senecio</i>	0–56	–
	scarlet globemallow	SPCO	<i>Sphaeralcea coccinea</i>	0–56	–
	white heath aster	SYERE	<i>Symphotrichum ericoides</i> var. <i>ericoides</i>	0–56	–

	ironweed	VERNU	<i>vernonia</i>	0–56	–
	American vetch	VIAM	<i>Vicia americana</i>	0–56	–
<b>Shrub/Vine</b>					
7	<b>Shrubs</b>			140–420	
	silver sagebrush	ARCA13	<i>Artemisia cana</i>	140–280	–
	sand sagebrush	ARFI2	<i>Artemisia filifolia</i>	0–140	–
	western sandcherry	PRPUB	<i>Prunus pumila var. besseyi</i>	0–140	–
	rose	ROSA5	<i>Rosa</i>	0–140	–
	western snowberry	SYOC	<i>Symphoricarpos occidentalis</i>	0–140	–
	leadplant	AMCA6	<i>Amorpha canescens</i>	0–56	–
	plains pricklypear	OPPO	<i>Opuntia polyacantha</i>	0–56	–
<b>Tree</b>					
8	<b>Trees</b>			140–420	
	plains cottonwood	PODEM	<i>Populus deltoides ssp. monilifera</i>	140–420	–
	boxelder	ACNE2	<i>Acer negundo</i>	0–140	–
	green ash	FRPE	<i>Fraxinus pennsylvanica</i>	0–140	–

## Animal community

### Wildlife Interpretations:

Reference Plant Community— Mid- and Tallgrasses, Shrubs, Plains Cottonwood (Diverse-Age Class):

The predominance of grasses plus high forb diversity in this community favors large grazers such as pronghorn and elk. Suitable thermal and escape cover for mule deer is limited due to low shrub cover. White and black-tailed jackrabbit, badger, and coyote commonly use this community. The Reference Plant Community also provides habitat for a wide array of smaller mammals, which support raptors, such as ferruginous and Swainson's hawks. Birds such as western kingbird, western meadowlark, lark bunting, and grasshopper sparrow utilize this community for nesting and foraging. This community is especially favorable for ground-nesting birds because of the abundant residual vegetation available in the spring for nesting and escape and thermal cover. The overstory of large cottonwoods provides habitat for a variety of birds ranging from raptors to neo-tropical migrants.

1.2 Community— Decreased Mid- and Tallgrasses, Increased Blue Grama, Cottonwood (Single-Age Class):

This plant community may be useful for the same large grazers that would use the Reference Plant Community. However, the plant community composition is less diverse, and thus, less apt to meet the seasonal needs of these animals. The overstory of large cottonwoods provides habitat for a variety of birds, ranging from raptors to neo-tropical migrants.

1.3 Community—Excessive Litter, Decadent Plants, and Standing Dead Canopy:

This community has reduced habitat value for most wildlife species found in the Reference Plant Community.

2.1 Community—Blue Grama, and Threadleaf Sedge, Decadent Plains Cottonwoods: This community may still be useful for the same large grazers that would use the Reference Plant Community. However, the plant community composition is less diverse, and thus, less apt to meet the seasonal needs of these animals. The overstory of large cottonwoods still provides some habitat for a variety of birds ranging from raptors to neo-tropical migrants.

3.1 Community—Kentucky Bluegrass, Smooth Brome, Noxious weeds, Russian Olive:

This community has low habitat value for most wildlife species.

### Grazing Interpretations:

The following table is a guide to stocking rates for the plant communities described in the Sandy Lowland site. These are conservative estimates for initial planning. On-site conditions will vary, and stocking rates should be adjusted based on range inventories, animal kind/class, forage availability (adjusted for slope, distance to water), and the type of grazing system (number of pastures, planned moves, etc.), all of which is determined in the conservation planning process.

The following stocking rates are based on the total annual forage production in a normal year multiplied by 25 percent harvest efficiency of preferred and desirable forage species, divided by 912 pounds of ingested air-dry vegetation for an animal unit per month (Natl. Range and Pasture Handbook, 1997). An animal unit month (AUM) is defined as the amount of forage required by one mature cow, and a calf up to six months, for one month. Plant Community (PC) Production (total lbs. /acre in a normal year) and Stocking Rate (AUMs/acre) are listed below:

Example: Reference PC – (2500) (.69)

1,800 lbs. per acre X 25 percent Harvest Efficiency = 625 lbs. forage demand for one month. Then, 625 lbs. per acre/912 demand per AUM =.69

Plant Community (PC) Production (lbs.ac), and Stocking Rate (AUM/Acre)

Reference PC - (2500) (0.69)

1.2 PC - (1750) (0.48)

2.1 PC - (1250) (0.34)

Grazing by domestic livestock is one of the major income-producing industries in the area. Rangelands in this area provide year-long forage under prescribed grazing for cattle, sheep, horses, and other herbivores. During the dormant period, livestock may need supplementation based on reliable forage analysis.

An on-site inventory is required prior to development of a grazing plan.

## **Hydrological functions**

Water is the principal factor limiting forage production on this site. This site is dominated by soils in hydrologic group B and C. Infiltration ranges from moderate to rapid. Runoff potential for this site varies from moderate to high depending on soil hydrologic group and ground cover. In many cases, areas with greater than 75 percent ground cover have the greatest potential for high infiltration and lower runoff. An example of an exception would be where short-grasses form a strong sod and dominate the site. Areas where ground cover is less than 50 percent have the greatest potential to have reduced infiltration and higher runoff (refer to NRCS Section 4, National Engineering Handbook (USDA–NRCS, 1972–2012) for runoff quantities and hydrologic curves).

Rills and gullies should not typically be present. Water flow patterns should be barely distinguishable if at all present. Pedestals are only slightly present in association with bunchgrasses. Litter typically falls in place, and signs of movement are not common. Chemical and physical crusts are rare to non-existent. Cryptogamic crusts are present, but only cover 1 to 2 percent of the soil surface.

## **Recreational uses**

This site provides hunting, hiking, photography, bird watching, and other opportunities. The wide varieties of plants that bloom from spring until fall have an aesthetic value that appeals to visitors.

## **Wood products**

Limited value for campfire and fireplace wood.

## **Other products**

None noted.

## **Other information**

## Site Development & Testing Plan

General Data (MLRA and Revision Notes, Hierarchical Classification, Ecological Site Concept, Physiographic, Climate, and Water Features, and Soils Data):

Updated. All "Required" items complete to Provisional level

Community Phase Data (Ecological Dynamics, STM, Transition & Recovery Pathways, Reference Plant Community, Species Composition List, Annual Production Table):

Updated. All "Required" items complete to Provisional level.

Annual Production Table is from the "Previously Approved" ESD (2008).

Growth Curves are from the "Previously Approved" ESD (2008).

The Annual Production Table, Species Composition List, and Growth Curves will be reviewed for future updates at Approved level.

Each Alternative State/Community:

Complete to Provisional level.

Supporting Information (Site Interpretations, Assoc. & Similar Sites, Inventory Data References, Agency/State Correlation, References):

Updated. All "Required" items complete to Provisional level.

Wildlife Interpretations: Plant community names updated. Narrative is from "Previously Approved" ESD (2008). Wildlife species will need to be updated at the next Approved level.

Livestock Interpretations: Plant community names and stocking rates updated.

Hydrology, Recreational Uses, Wood Products, and Other Products carried over from previously "Approved" ESD (2008).

Plant Preferences tabled removed. Will be released as a technical guide notice by NE and WY state offices in the future.

Existing NRI or 417 Inventory Data References updated. More field data collection is needed to support this site concept.

## Reference Sheet

Rangeland Health Reference Sheet carried over from previously "Approved" ESD (2008).

It will be updated at the next "Approved" level.

"Future work, as described in a project plan, to validate the information in this provisional ecological site description is needed. This will include field activities to collect low and medium intensity sampling, soil correlations, and analysis of that data. Annual field reviews should be done by soil scientists and vegetation specialists. A final field review, peer review, quality control, and quality assurance reviews of the ESD will be needed to produce the final document." (NI 430\_306 ESI and ESD, April, 2015)

## Inventory data references

Information presented here has been derived from data collection on private and federal lands using:

- Double Sampling (clipped 2 of 5 plots)\*
- Rangeland Health (Pellant et al., 2005)
- Soil Stability (Pellant et al., 2005)



- Line Point Intercept : Foliar canopy, basal cover (Forb, Graminoid, Shrub, subshrub, Lichen, Moss, Rock fragments, bare ground, % Litter) (Herrick et al., 2005)
- Soil pedon descriptions collected on site (Schoeneberger et al., 2012)

\*NRCS double-sampling method, CO NRCS Similarity Index Worksheet 528(1).

Additional reconnaissance data collection using numerous ocular estimates and other inventory data; NRCS clipping data for USDA program support; Field observations from experienced range trained personnel. Specific data information is contained in individual landowner/user case files and other files located in county NRCS field offices.

Data Source: NRI

Number of Records: 5

Sample Period: 2005-2013

State: WY

Counties: Goshen, Platte

Data Source: R-417

Number of Records: 2

Sample Period: 1980, 1985

State: CO, WY

Counties: Weld, Goshen

## References

Guyette, R.P., M.C. Stambaugh, D.C. Dey, and R. Muzika. 2012. Predicting Fire Frequency with Chemistry and Climate. *Ecosystems* 15:322–335.

Stewart, O.C., H.T. Lewis, and M.K. Anderson. 2002. *Forgotten Fires: Native Americans and the Transient Wilderness*. University of Oklahoma Press, Norman, OK. 351p.

## Other references

Anderson, R.C. 2006. Evolution and origin of the central grassland of North America: Climate, fire, and mammalian grazers. In: *Journal of the Torrey Botanical Society* 133:626–647.

Bragg, T.B. 1995. The physical environment of the Great Plains grasslands. In: A. Joern and K.H. Keeler (eds.) *The changing prairie*, Oxford University Press, Oxford, UK. pp. 49–81.

Branson, D.H., and G.A. Sword. 2010. An experimental analysis of grasshopper community responses to fire and livestock grazing in a northern mixed-grass prairie. In: *Environmental Entomology* 39:1441–1446.

Brinson, M.M. 1993. A hydrogeomorphic classification for wetlands. Technical Report WRP–DE–4. U.S. Army Corps of Engineers Waterways Experiment Station, Vicksburg, MS.

Cleland, D., P. Avers, W.H. McNab, M. Jensen, R. Bailey, T. King, and W. Russell. 1997. National hierarchical framework of ecological units. In: *Ecosystem Management: applications for sustainable forest and wildlife resources*, Yale University Press  
 Coupland, R.T. 1958. The effects of fluctuations in weather upon the grasslands of the Great Plains. *Botanical Review* 24:273–317.

Davis, S.K., R.J. Fisher, S.L. Skinner, T.L. Shaffer, and R.M. Brigham. 2013. Songbird abundance in native and planted grassland varies with type and amount of grassland in the surrounding landscape. In: *Journal of Wildlife Management* 77:908–919.

DeLuca, T.H., and P. Lesica. 1996. Long-term harmful effects of crested wheatgrass on Great Plains grassland ecosystems. In: *Journal of Soil and Water Conservation* 51:408–409.

- Derner, J.D., and R.H. Hart. 2007. Grazing-induced modifications to peak standing crop in northern mixed-grass prairie. In: *Rangeland Ecology and Management* 60:270–276.
- Derner, J.D., and A.J. Whitman. 2009. Plant interspaces resulting from contrasting grazing management in northern mixed-grass prairie: Implications for ecosystem function. In: *Rangeland Ecology and Management* 62:83–88.
- Derner, J.D., W.K. Lauenroth, P. Stapp, and D.J. Augustine. 2009. Livestock as ecosystem engineers for grassland bird habitat in the western Great Plains of North America. In: *Rangeland Ecology and Management* 62:111–118.
- Dillehay, T.D. 1974. Late Quaternary bison population changes on the southern Plains. In: *Plains Anthropologist* 19:180–196.
- Dormaar, J.F., and S. Smoliak. 1985. Recovery of vegetative cover and soil organic matter during revegetation of abandoned farmland in a semiarid climate. In: *Journal of Range Management* 38:487–491.
- Fenneman, N.M., and D.W. Johnson. 1946. Physical divisions of the United States. U.S. Geological Survey, Physiographic Committee. Scale 1:700,000.
- Harmony, K.R. 2007. Grazing and burning Japanese brome (*Bromus japonicus*) on mixed grass rangelands. In: *Rangeland Ecology and Management* 60:479–486.
- Heitschmidt, R.K., and L.T. Vermeire. 2005. An ecological and economic risk avoidance drought management decision support system. In: J.A. Milne (ed.) *Pastoral systems in marginal environments*, 20th International Grasslands Congress, July 2005. p. 178.
- Knopf, F.L. 1996. Prairie legacies—Birds. In: F.B. Samson and F.L. Knopf (eds.) *Prairie conservation: Preserving North America's most endangered ecosystem*, Island Press, Washington, DC. pp. 135–148.
- Knopf, F.L., and F.B. Samson. 1997. Conservation of grassland vertebrates. In: F.B. Samson and F.L. Knopf (eds.) *Ecology and conservation of Great Plains vertebrates: Ecological Studies 125*, Springer-Verlag, New York, NY. pp. 273–289.
- Lauenroth, W.K., O.E. Sala, D.P. Coffin, and T.B. Kirchner. 1994. The importance of soil water in recruitment of *Bouteloua gracilis* in the shortgrass steppe. In *Ecological Applications* 4:741–749.
- Laycock, W.A. 1988. History of grassland plowing and grass planting on the Great Plains. In: J.E. Mitchell (ed.) *Impacts of the conservation Reserve Program in the Great Plains—symposium proceedings, September 16–18, 1987*. USDA Forest Service, Rocky Mountain Forest and Range Experiment Station, General Technical Report RM-158.
- Malloch, D.W., K.A. Pirozynski, and P.H. Raven. 1980. Ecological and evolutionary significance of mycorrhizal symbioses in vascular plants (a review). *Proceedings of the National Academy of Sciences* 77:2113–2118.
- Ogle, S.M., W.A. Reiners, and K.G. Gerow. 2003. Impacts of exotic annual brome grasses (*Bromus* spp.) on ecosystem properties of the northern mixed grass prairie. In *American Midland Naturalist* 149:46–58.
- Roath, L.R. 1988. Implications of land conversions and management for the future. In: J.E. Mitchell (ed.) *Impacts of the Conservation Reserve Program in the Great Plains—symposium proceedings, September 16–18, 1987*. USDA Forest Service, Rocky Mountain Forest and Range Experiment Station, General Technical Report RM-158.
- Smoliak, S., and J.F. Dormaar. 1985. Productivity of Russian wildrye and crested wheatgrass and their effect on prairie soils. In: *Journal of Range Management* 38:403–405.
- Smoliak, S., J.F. Dormaar, and A. Johnston. 1972. Long-term grazing effects on *Stipa-Bouteloua* prairie soils. In: *Journal of Range Management* 25:246–250.
- Soil Science Division Staff. 2017. Soil survey manual. C. Ditzler, K. Scheffe, and H.C. Monger (eds.) USDA

Handbook 18. Government Printing Office, Washington, DC.

Soil Survey Staff. Official Soil Series Descriptions. USDA Natural Resources Conservation Service. [https://www.nrcs.usda.gov/wps/portal/nrcs/detail/soils/home/?cid=nrcs142p2\\_053587](https://www.nrcs.usda.gov/wps/portal/nrcs/detail/soils/home/?cid=nrcs142p2_053587) (accessed 15 November 2017).

Soil Survey Staff. Soil Survey Geographic (SSURGO) database. USDA Natural Resources Conservation Service.

Soil Survey Staff. 2014. Keys to Soil Taxonomy, 12th edition. USDA Natural Resources Conservation Service, Washington, DC.

Soil Survey Staff. 2018. Web Soil Survey. USDA Natural Resources Conservation Service. <https://websoilsurvey.nrcs.usda.gov/app/> (accessed 15 February 2018).

Soller, D.R. 2001. Map showing the thickness and character of Quaternary sediments in the glaciated United States east of the Rocky Mountains. In: U.S. Geological Survey Miscellaneous Investigations Series I-1970-E, scale 1:3,500,000.

U.S. Army Corps of Engineers. 1987. Corps of Engineers wetlands delineation manual. Wetlands Research Program Technical Report Y-87-1 (<http://www.lrh.usace.army.mil/Portals/38/docs/USACE%2087%20Wetland%20Delineation%20Manual.pdf>). Waterways Experiment Station, Vicksburg, MS.

U.S. Department of Agriculture, Natural Resources Conservation Service. Glossary of landform and geologic terms. National Soil Survey Handbook, Title 430-VI, Part 629.02c. [http://www.nrcs.usda.gov/wps/portal/nrcs/detail/soils/ref/?cid=nrcs142p2\\_054242](http://www.nrcs.usda.gov/wps/portal/nrcs/detail/soils/ref/?cid=nrcs142p2_054242) (accessed 16 January 2018).

U.S. Department of Agriculture, Natural Resources Conservation Service. 2010a. Field indicators of hydric soils in the United States, version 7.0. L.M. Vasilas, G.W. Hurt, and C.V. Noble (eds.) USDA-NRCS, in cooperation with the National Technical Committee for Hydric Soils.

U.S. Department of Agriculture, Natural Resources Conservation Service. 2013a. Climate data. National Water and Climate Center. <http://www.wcc.nrcs.usda.gov/climate> (accessed 13 October 2017).

U.S. Department of Agriculture, Natural Resources Conservation Service. 2013b. National Soil Information System. [https://www.nrcs.usda.gov/wps/portal/nrcs/detail/soils/survey/geo/?cid=nrcs142p2\\_053552](https://www.nrcs.usda.gov/wps/portal/nrcs/detail/soils/survey/geo/?cid=nrcs142p2_053552) (accessed 30 October 2017).

U.S. Department of the Interior, Geological Survey. 2008. LANDFIRE 1.1.0 Vegetation Dynamics Models. <http://landfire.cr.usgs.gov/viewer/>.

U.S. Department of the Interior, Geological Survey. 2011. LANDFIRE 1.1.0 Existing Vegetation Types. <http://landfire.cr.usgs.gov/viewer/>.

Willeke, G.E. 1994. The national drought atlas [CD ROM]. U.S. Army Corps of Engineers, Water Resources Support Center, Institute for Water Resources Report 94-NDS-4.

Wilson, S.D., and J.M. Shay. 1990. Competition, fire, and nutrients in a mixed-grass prairie. In: *Ecology* 71:1959–1967.

With, K.A. 2010. McCown's longspur (*Rhynchophanes mccownii*). In: A. Poole (ed.) *The birds of North America* [online], Cornell Lab of Ornithology, Ithaca, NY. <https://birdsna.org/Species-Account/bna/home>.

Augustine, D.J., J. Derner, D. Milchunas, D. Blumenthal, and L. Porensky. 2017. Grazing moderates increases in C3 grass abundance over seven decades across a soil texture gradient in shortgrass steppe. In *Journal of Vegetation Science*, Doi:10.1111/jvs.12508, International Association of Vegetative Science.

- Augustine, D.J., J. Derner, J.K. Detling. 2014. Testing for thresholds in a semiarid grassland: The influence of prairie dogs and plague. In: *Rangeland Ecology & Management* 67(6).
- Butler, LD., J.B. Cropper, R.H. Johnson, A.J. Norman, G.L. Peacock, P.L. Shaver and K.E. Spaeth. 1997, revised 2003. *National Range and Pasture Handbook*. National Cartography and Geospatial Center's Technical Publishing Team: Fort Worth, TX. Available online. <http://www.glti.nrcs.usda.gov/technical/publications/nrph.html>. Accessed February 26, 2018.
- Clark, J., E. Grimm, J. Donovan, S. Fritz, D. Engrstom, and J. Almendinger. 2002. Drought cycles and landscape responses to past aridity on prairies of the Northern Great Plains, USA. In: *Ecology*, 83(3), 595-601.
- Collins, S., and S. Barber. (1985). Effects of disturbance on diversity in mixed-grass prairie. In: *Vegetatio*, 64, 87-94.
- Cooperative climatological data summaries. NOAA. Western Regional Climate Center: Reno, NV. Available online. <http://www.wrcc.dri.edu/climatedata/climsum>. Accessed November 16, 2017.
- Egan, T. 2006. *The Worst hard time*. Houghton Mifflin Harcourt Publishing Company: New York, NY.
- Hart, R. and J. Hart. 1997. Rangelands of the Great Plains before European settlement. In: *Rangelands*, 19(1), 4-11.
- Hart, R. 2001. Plant biodiversity on shortgrass steppe after 55 years of zero, light, moderate, or heavy cattle grazing. In: *Plant Ecology*, 155, 111-118.
- Pellant, M., P. Shaver, D.A. Pyke, J.E. Herrick. (2005) *Interpreting Indicators of Rangeland Health, Version 4*.
- Mack, R.N., and J.N. Thompson. 1982. Evolution in steppe with few large, hooved mammals. In: *The American Naturalist*. 119, No. 6, 757-773.
- Reyes-Fox, M., Stelzer H., Trlica M.J., McMaster, G.S., Andales, A.A., LeCain, D.R., and Morgan J.A. 2014. Elevated CO<sub>2</sub> further lengthens growing season under warming conditions. In: *Nature*, April 23, 2014. . Accessed 1 March, 2017.
- Schoeneberger, P.J., D.A. Wysockie, E.C. Benham, and Soil Survey Staff. 2012. *Field book for describing and sampling soils, Version 3.0*. Natural Resources Conservation Service, National Soil Survey Center: Lincoln, NE.
- Stahl, D. W., E.R. Cook, M.K. Cleaveland, M.D. Therrell, D.M. Meko, H.D. Grissino-Mayer, E. Watson, and B.H. Luckman. Tree-ring data document 16th century megadrought over North America. 2000. In: *Eos*, 81(12), 121-125.
- Zelikova, T. J., D.M. Blumenthal, D.G. Williams, L. Souza, D.R. LeCain, J.Morgan. 2014. Long-term exposure to elevated CO<sub>2</sub> enhances plant community stability by suppressing dominant plant species in a mixed-grass prairie. In: *Ecology*, 2014. [www.pnas.org/cgi/doi/10.1073/pnas.1414659111](http://www.pnas.org/cgi/doi/10.1073/pnas.1414659111)
- U.S. Dept. of Agriculture, Natural Resources Conservation Service. 2009. Part 630, Hydrology, National Engineering Handbook.
- U.S. Dept. of Agriculture, Natural Resources Conservation Service. 1972-2012. *National Engineering Handbook Hydrology Chapters*. <http://www.nrcs.usda.gov/wps/portal/nrcs/detailfull/national/water/?&cid=stelprdb1043063>. Accessed August, 2015).
- U.S. Dept. of Agriculture, Natural Resources Conservation Service. *National Soil Survey Handbook title 430-VI*. Available online. [http://www.nrcs.usda.gov/wps/portal/nrcs/detail/soils/ref/?cid=nrcs142p2\\_054242](http://www.nrcs.usda.gov/wps/portal/nrcs/detail/soils/ref/?cid=nrcs142p2_054242). Accessed February 26, 2018.
- U.S. Dept. of Agriculture, Natural Resources Conservation Service. *Web Soil Survey*. Available online. <http://websoilsurvey.sc.egov.usda.gov/App/WebSoilSurvey.aspx>. Accessed November 15, 2017.
- Data collection for the Saline Upland ecological site was done in conjunction with the progressive soil surveys within

the 67A Central High Plains (Northern Part) of Nebraska, Wyoming, and Colorado. It has been mapped and correlated with soils in the following soil surveys:

U.S. Dept. of Agriculture. 1994. Soil Survey of Banner County, Nebraska.

U.S. Dept. of Agriculture. 1997. Soil Survey of Cheyenne County, Nebraska.

U.S. Dept. of Agriculture. 1999. Soil Survey of Garden County, Nebraska.

U.S. Dept. of Agriculture. 2005. Soil Survey of Kimball County, Nebraska.

U.S. Dept. of Agriculture. 1985. Soil Survey of Morrill County, Nebraska.

U.S. Dept. of Agriculture. 1968 Soil Survey of Scotts Bluff County, Nebraska.

U.S. Dept. of Agriculture. 2013. Soil Survey of Scotts Bluff National Monument, Nebraska.

U.S. Dept. of Agriculture. 1998. Soil Survey of Sioux County, Nebraska.

U.S. Dept. of Agriculture. 1981. Soil Survey of Goshen County, Northern Part, Wyoming.

U.S. Dept. of Agriculture. 1971. Soil Survey of Goshen County, Southern Part, Wyoming.

U.S. Dept. of Agriculture. 1983. Soil Survey of Laramie County, Eastern Part, Wyoming.

U.S. Dept. of Agriculture. 2001. Soil Survey of Laramie County, Western Part, Wyoming.

U.S. Dept. of Agriculture. 2003. Soil Survey of Platte County, Wyoming.

U.S. Dept. of Agriculture. 1982. Soil Survey of Weld County, Northern Part, Colorado.

For manuscripts of archived soil surveys, see: <https://websoilsurvey.nrcs.usda.gov/app/WebSoilSurvey.aspx>

## **Contributors**

Kimberly Diller, Ecological Site Specialist, NRCS MLRA SSO, Pueblo CO

Andy Steinert, MLRA 67B Soil Survey Leader, NRCS MLRA SSO, Fort Morgan, CO

Doug Whisenhunt, Ecological Site Specialist, NRCS MLRA SSO, Pueblo CO

## **Approval**

Kirt Walstad, 9/07/2023

## **Acknowledgments**

Partners/Contributors:

David Cook, Rangeland Management Specialist, NRCS, Oshkosh, NE

George Gamblin, Rangeland Management Specialist, NRCS, Wheatland, WY

Cameron Clark, Resource Soil Scientist, NRCS, Douglas, WY

Angie Elg, Resource Soil Scientist, NRCS, Scottsbluff, NE

Tim Becket, Area Resource Conservationist, Douglas, WY

Mitchell Stephenson, Ph.D. Rangeland Management Specialist, UNL-Panhandle Research Station, Scottsbluff, NE

Kristin Dickinson, District Conservationist, NRCS, Sidney, NE

Rick Peterson, Ecological Site Inventory Specialist, SD-NRCS-MLRA SSO, Rapid City, SD

Program Support:

Nadine Bishop, NE State Rangeland Management Specialist/ QC, NRCS, Imperial, NE

John Hartung WY State Rangeland Management Specialist/ QC, NRCS, Casper, WY

David Kraft, NRCS MLRA Ecological Site Specialist-QA, Emporia, KS  
 James Bauchert, WY State Soil Scientist, WY-NRCS, Casper, WY  
 Neil Dominy, NE State Soil Scientist, NRCS, Lincoln, NE  
 Britt Weiser, NE State Resource Conservationist, NRCS, Lincoln, NE  
 Clayton Schmitz, WY State Resource Conservationist, NRCS, Casper, WY  
 Carla Green Adams, Editor, NRCS-SSR5, Denver, CO  
 Chad Remley, Regional Director, N. Great Plains Soil Survey, Salina, KS  
 Those involved in developing the 2008 version: Chuck Ring, Rangeland Management Specialist, WY-NRCS,  
 Everett Bainter, WY State Rangeland Management Specialist, WY-NRCS

**Non-discrimination statement**

In accordance with Federal civil rights law and U.S. Department of Agriculture (USDA) civil rights regulations and policies, the USDA, its Agencies, offices, and employees, and institutions participating in or administering USDA programs are prohibited from discriminating based on race, color, national origin, religion, sex, gender identity (including gender expression), sexual orientation, disability, age, marital status, family/parental status, income derived from a public assistance program, political beliefs, or reprisal or retaliation for prior civil rights activity, in any program or activity conducted or funded by USDA (not all bases apply to all programs). Remedies and complaint filing deadlines vary by program or incident.

Persons with disabilities who require alternative means of communication for program information (e.g., Braille, large print, audiotope, American Sign Language, etc.) should contact the responsible Agency or USDA's TARGET Center at (202) 720-2600 (voice and TTY) or contact USDA through the Federal Relay Service at (800) 877-8339. Additionally, program information may be made available in languages other than English.

To file a program discrimination complaint, complete the USDA Program Discrimination Complaint Form, AD-3027, found online at How to File a Program Discrimination Complaint and at any USDA office or write a letter addressed to USDA and provide in the letter all of the information requested in the form. To request a copy of the complaint form, call (866) 632-9992. Submit your completed form or letter to USDA by: (1) mail: U.S. Department of Agriculture, Office of the Assistant Secretary for Civil Rights, 1400 Independence Avenue, SW, Washington, D.C. 20250-9410; (2) fax: (202) 690-7442; or (3) email: program.intake@usda.gov.

**Rangeland health reference sheet**

Interpreting Indicators of Rangeland Health is a qualitative assessment protocol used to determine ecosystem condition based on benchmark characteristics described in the Reference Sheet. A suite of 17 (or more) indicators are typically considered in an assessment. The ecological site(s) representative of an assessment location must be known prior to applying the protocol and must be verified based on soils and climate. Current plant community cannot be used to identify the ecological site.

Author(s)/participant(s)	Dave Cook, Kristin Dickinson, George Gamblin, John Hartung, Andy Steinert, Nadine Bishop
Contact for lead author	
Date	11/23/2020
Approved by	Kirt Walstad
Approval date	
Composition (Indicators 10 and 12) based on	Annual Production

**Indicators**

1. **Number and extent of rills:** None. Rills are not expected on the site.
-

2. **Presence of water flow patterns:** Typically, none. None, or barely visible. Evidence of water flow may be present after high overland flow events or flooding from adjacent streams, but vegetation normally remains intact.

---

3. **Number and height of erosional pedestals or terracettes:** None. Erosional pedestals or terracettes are not expected on the site.

---

4. **Bare ground from Ecological Site Description or other studies (rock, litter, lichen, moss, plant canopy are not bare ground):** Bare ground is typically less than 10 percent, occurring in small areas (less than 2 to 3 inches in diameter) scattered throughout site.

---

5. **Number of gullies and erosion associated with gullies:** None. Gullies should not be present on this site.

---

6. **Extent of wind scoured, blowouts and/or depositional areas:** None. Wind-scoured and/or depositional areas are not present on the site.

---

7. **Amount of litter movement (describe size and distance expected to travel):** Litter should fall in place. Slight amount of movement of fine litter from water is possible, but not normal. Litter movement from wind is not expected.

---

8. **Soil surface (top few mm) resistance to erosion (stability values are averages - most sites will show a range of values):** Soil aggregate stability ratings should typically be 4 or greater. Surface organic matter adheres to the soil surface. Soil surface peds will typically retain structure indefinitely when dipped in distilled water.

---

9. **Soil surface structure and SOM content (include type of structure and A-horizon color and thickness):** The surface layer ranges from 3 to 8 inches (7.2-20.3 cm) thick. Soil colors range from yellowish brown to light brownish gray (values of 5 to 6) when dry and dark grayish brown, brown, to dark brown (values of 3 to 4) when moist. Soil surface structure is typically granular or single grain but may be massive or weak subangular blocky. Soils typically contain carbonates at the surface, but on some sites, they may be leached to 8 inches (20.3 cm).

---

10. **Effect of community phase composition (relative proportion of different functional groups) and spatial distribution on infiltration and runoff:** The functional/structural groups provide a combination of rooting depths and structure which positively influences infiltration. Combination of shallow and deep rooted species (mid & tall rhizomatous and tufted perennial cool season grasses) with fine and coarse roots positively influences infiltration.

The expected composition of the plant community is 65 to 85 percent perennial grasses and grass-likes, 5 to 10 percent forbs, and 5 to 10 percent shrubs. Trees can make up 5 to 15 percent of the total annual production.

The grass and grass-like component is made up of cool-season, bunch grasses (15-40%); warm-season, tall, rhizomatous grasses (10-35%); warm-season mid-grasses (10-30%); warm-season, short grasses (5-15%); cool-season, rhizomatous grasses (5-10%) and grass-likes (1-10%).

---

11. **Presence and thickness of compaction layer (usually none; describe soil profile features which may be mistaken for compaction on this site):** None. No compaction layer should be present.
- 

12. **Functional/Structural Groups (list in order of descending dominance by above-ground annual-production or live foliar cover using symbols: >>, >, = to indicate much greater than, greater than, and equal to):**

Dominant: 1. Native, C3, bunch grasses – 375-1000 #/ac (15-40%), 1 species minimum  
2. Native, C4, tall, rhizomatous grasses – 250-875 #/ac (10-35%), 2 species minimum  
3. Native, C4, mid-grasses – 250-750 (10-30%), 1 species minimum

Sub-dominant: 4. Native Trees – 125-375 #/ac (5-15%), 1 species minimum  
5. Shrubs, Vines, Cacti – 125-375 #/ac (5-15%), 1 species minimum

Other: MInor:

6. Native, C3, rhizomatous grasses – 125-250 #/ac (5-10%)  
7. Native, C4, short grasses – 125-250 #/ac (5-10%)  
8. Native, Perennial and Annual Forbs – 125-250 #/ac (5-10%)  
9. Grass-likes – 25-250 #/ac (1-10%)

Additional: Community 1.1:

12a. Relative Dominance:

Native, C3 bunch grasses > Native, C4, tall, rhizomatous grasses > Native, C4, mid-grasses > Trees = = Shrubs, Cacti, Vines > Native, C3, rhizomatous grasses = Native, C4, short grasses > Native, Perennial and Annual Forbs > Grass-likes

12b. F/S Groups not expected for the site: Introduced annual grasses, perennial introduced and naturalized grasses, coniferous trees.

12c. Number of F/S Groups: 9

12d. Species number in Dominant and Sub-dominant F/S Groups: 6

---

13. **Amount of plant mortality and decadence (include which functional groups are expected to show mortality or decadence):** Very little evidence of decadence or mortality. Bunch grasses have strong, healthy centers with less than 3 percent mortality and shrubs have few dead stems.
- 

14. **Average percent litter cover (%) and depth ( in):** Plant litter cover is evenly distributed throughout the site and is expected to be 70 to 90 percent. Litter depth is expected to be 0.50-1.0 inch (1.3-2.5 cm).
- 

15. **Expected annual annual-production (this is TOTAL above-ground annual-production, not just forage annual-production):** Annual production ranges from 2,000 pounds per acre during unfavorable years to 3,000 pounds per acre in above average years on an air dry basis. Average annual production is 2,500 pounds per acre under normal precipitation and weather conditions. No significant reduction is expected the growing season following wildfire.
- 

16. **Potential invasive (including noxious) species (native and non-native). List species which BOTH characterize degraded states and have the potential to become a dominant or co-dominant species on the ecological site if their future establishment and growth is not actively controlled by management interventions. Species that**



**become dominant for only one to several years (e.g., short-term response to drought or wildfire) are not invasive plants. Note that unlike other indicators, we are describing what is NOT expected in the reference state for the ecological site:** Spreading buckwheat, kochia, Russian thistle, pricklypear, Canada thistle, musk thistle, hound's tongue, Russian olive, saltcedar (tamarisk) and others as they become known.

See:

Department of Agriculture Invasive Species Website:

<https://www.colorado.gov/pacific/agconservation/noxious-weed-species>

Wyoming Weed and Pest Council Website: <https://wyoweed.org/>

Nebraska Invasive Species website: <https://neinvasives.com/plants>.

- 
17. **Perennial plant reproductive capability:** All perennial species exhibit high vigor relative to recent weather conditions. Perennial grasses should have vigorous rhizomes or tillers; vegetative and reproductive structures are not stunted. All perennial species should be capable of reproducing annually.
-