

Ecological site R108XB013IL

Loamy Outwash Prairie

Last updated: 5/27/2020
Accessed: 05/07/2024

General information

Provisional. A provisional ecological site description has undergone quality control and quality assurance review. It contains a working state and transition model and enough information to identify the ecological site.

MLRA notes

Major Land Resource Area (MLRA): 108X–Illinois and Iowa Deep Loess and Drift

The Illinois and Iowa Deep Loess and Drift, East-Central Part (MLRA 108B) includes the Rock River Hill Country, Grand Prairie, and Western Forest-Prairie physiographic divisions (Schewman et al. 1973). It falls entirely in one state (Illinois), encompassing approximately 7,450 square miles (Figure 1). The elevation ranges from approximately 985 feet above sea level (ASL) in the northern and western parts to 660 feet ASL in south and west. Local relief is mainly 3 to 10 feet on the broad, upland flats and about 160 feet along the major streams and dissected drainageways. Wisconsin-aged loess forms a moderately thin to thick layer across the entire area with Illinoian glacial drift below. Bedrock lies beneath the glacial material with Pennsylvania shales, siltstones, and limestones in the south and west and Ordovician and Silurian limestone in the extreme north. This bedrock can be exposed on bluffs along the major rivers (USDA-NRCS 2006).

The vegetation in the MLRA has undergone drastic changes over time. At the end of the last glacial episode – the Wisconsin glacial episode – the evolution of vegetation began with the development of tundra habitats, followed by a phase of spruce and fir forests, and eventually spruce-pine forests. Not until approximately 9,000 years ago did the climate undergo a warming trend which prompted the development of deciduous forests dominated by oak and hickory. As the climate continued to warm and dry, prairies began to develop approximately 8,300 years ago. Another shift in climate that resulted in an increase in moisture prompted the emergence of savanna-like habitats from 8,000 to 5,000 years before present. Moisture continued to increase in the southernmost region 5,000 years ago, resulting in an increase of forested systems (Taft et al. 2009). Fire, droughts, and grazing by native mammals helped to maintain the prairies and savannas until the arrival of European settlers, and the forests were maintained by droughts, wind, lightning, and occasional fire (Taft et al. 2009; NatureServe 2018).

Classification relationships

USFS Subregions: Southwestern Great Lakes Morainal (222K), Central Till Plains-Oak Hickory Section (223G), Central Dissected Till Plains (251C), and Central Till Plains and Grand Prairies (251D) Sections; Rock River Old Drift Country (222Kh), Effingham Plain (222Ga), Mississippi River and Illinois Alluvial Plains (251 Cf), East Mississippi River Hills (251Ci), Galesburg Dissected Till Plain (251Cj), Carlinville Dissected Till Plain (251Ck), Green River Lowland (251Da), Western Grand Prairie (251Db), Northern Grand Prairie (251Dc), Southern Grand Prairie (251De), and Springfield Plains (251Df) Subsections (Cleland et al. 2007)

U.S. EPA Level IV Ecoregion: Illinois/Indiana Prairies (54a), Sand Area (54d), Rock River Hills (54g), and Western Dissected Illinoian Till Plain (72i) (USEPA 2013)

National Vegetation Classification – Ecological Systems: North-Central Interior Sand and Gravel Tallgrass Prairie (CES202.695) (NatureServe 2018)

National Vegetation Classification – Plant Associations: Schizachyrium scoparium – Sorghastrum nutans – Bouteloua curtipendula Gravel Grassland (CEGL005176) (Nature Serve 2018)

Biophysical Settings: North-Central Interior Sand and Gravel Tallgrass Prairie (BpS 4214120) (LANDFIRE 2009)

Illinois Natural Areas Inventory: Dry-mesic gravel prairie (White and Madany 1978)

Ecological site concept

Loamy Outwash Prairies are located within the green areas on the map (Figure 1). They occur on outwash plains and stream terraces in river valleys. The soils are Mollisols that are well-drained and deep, formed in loess or loamy sediments over outwash or loamy lacustrine deposits.

The historic pre-European settlement vegetation on this ecological site was dominated by midgrass prairie vegetation. Little bluestem (*Schizachyrium scoparium* (Michx.) Nash) and sideoats grama (*Bouteloua curtipendula* (Michx.) Torr.) are the dominant species on the site. Other grasses present can include Indiangrass (*Sorghastrum nutans* (L.) Nash), prairie dropseed (*Hesperostipa spartea* (A. Gray) A. Gray), and big bluestem (*Andropogon gerardii* Vitman) (White and Madany 1978; NatureServe 2018). Forbs typical of an undisturbed plant community associated with this ecological site include prairie goldenrod (*Oligoneuron album* (Nutt.) G.L. Nesom) and slimflower scurfpea (*Psoralidium tenuiflorum* (Pursh) Rydb.) (White and Madany; Taft et al. 1997). Fire is the primary disturbance factor that maintains this ecological site, while periodic drought and large mammal grazing are secondary factors (LANDFIRE 2009).

Associated sites

R108XB015IL	Wet Loamy Outwash Prairie Loess over outwash or eolian sand parent material that is shallow to the water table including Binghampton, Clyde, Hoopole, Lawler, Marshan, and Orio soils
-------------	---

Similar sites

R108XB016IL	Sand Prairie Sand Prairies are in a similar landscape position, but the parent material is sandy eolian deposits
-------------	--

Table 1. Dominant plant species

Tree	Not specified
Shrub	Not specified
Herbaceous	(1) <i>Schizachyrium scoparium</i> (2) <i>Bouteloua curtipendula</i>

Physiographic features

Loamy Outwash Prairies occur on outwash plains and stream terraces in river valleys (Figure 2). They are situated on elevations ranging from approximately 499 to 1948 feet ASL. The site does not experience flooding, but rather generates runoff to downslope, adjacent ecological sites (Table 1).

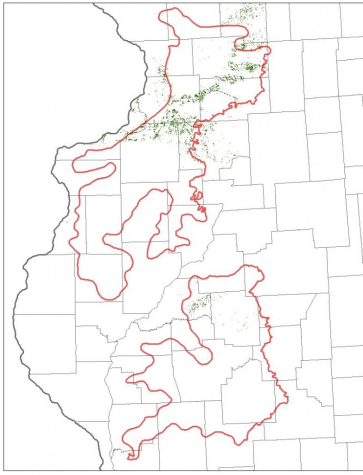

Figure 1. Location of Loamy Outwash Prairie ecological site within MLRA 108B.

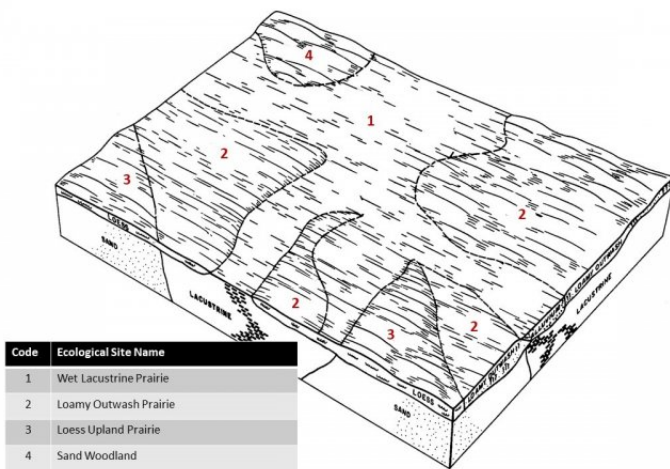

Figure 2. Representative block diagram of Loamy Outwash Prairie and associated ecological sites.

Table 2. Representative physiographic features

Slope shape across	(1) Convex
Slope shape up-down	(1) Convex
Landforms	(1) Outwash plain (2) River valley
Runoff class	Low to medium
Elevation	152–594 m
Slope	0–10%
Water table depth	203 cm
Aspect	Aspect is not a significant factor

Climatic features

The Illinois and Iowa Deep Loess and Drift, East-Central Part falls into the hot-summer humid continental climate (Dfa) and the humid subtropical continental climate (Cfa) Köppen-Geiger climate classifications (Peel et al. 2007). The two main factors that drive the climate of the MLRA are latitude and weather systems. Latitude, and the subsequent reflection of solar input, determines air temperatures and seasonal variations. Solar energy varies across the seasons, with summer receiving three to four times as much energy as opposed to winter. Weather systems (air masses and cyclonic storms) are responsible for daily fluctuations of weather conditions. High-pressure systems are responsible for settled weather patterns where sun and clear skies dominate. In fall, winter, and spring, the polar jet stream is responsible for the creation and movement of low-pressure systems. The clouds, winds, and precipitation associated with a low-pressure system regularly follow high-pressure systems every few

days (Angel n.d.).

The soil temperature regime of MLRA 108B is classified as mesic, where the mean annual soil temperature is between 46 and 59°F (USDA-NRCS 2006). Temperature and precipitation occur along a north-south gradient, where temperature and precipitation increase the further south one travels. The average freeze-free period of this ecological site is about 178 days, while the frost-free period is about 141 days (Table 2). The majority of the precipitation occurs as rainfall in the form of convective thunderstorms during the growing season. Average annual precipitation is approximately 36 inches, which includes rainfall plus the water equivalent from snowfall (Table 3). The average annual low and high temperatures are 40 and 60°F, respectively.

Climate data and analyses are derived from 30-year averages gathered from three National Oceanic and Atmospheric Administration (NOAA) weather stations contained within the range of this ecological site (Table 4).

Table 3. Representative climatic features

Frost-free period (characteristic range)	133-151 days
Freeze-free period (characteristic range)	173-183 days
Precipitation total (characteristic range)	889-940 mm
Frost-free period (actual range)	126-152 days
Freeze-free period (actual range)	169-185 days
Precipitation total (actual range)	889-965 mm
Frost-free period (average)	141 days
Freeze-free period (average)	178 days
Precipitation total (average)	914 mm

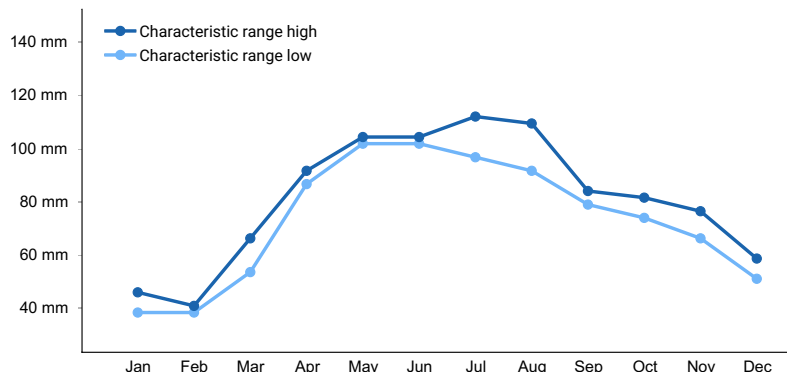

Figure 3. Monthly precipitation range

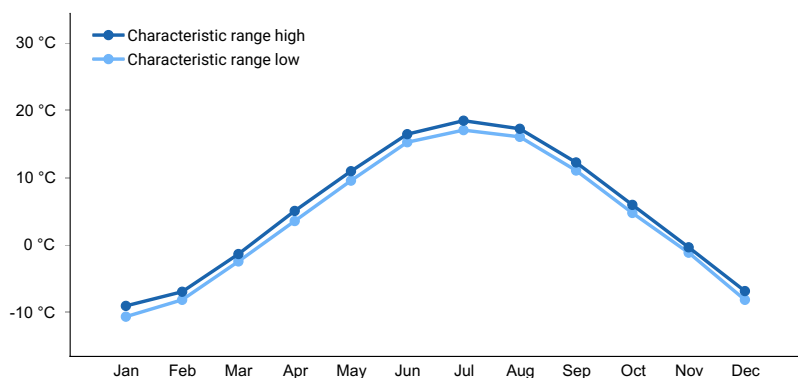

Figure 4. Monthly minimum temperature range

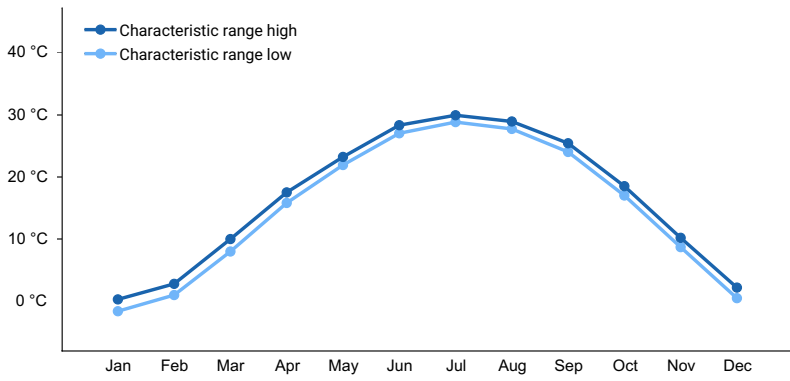

Figure 5. Monthly maximum temperature range

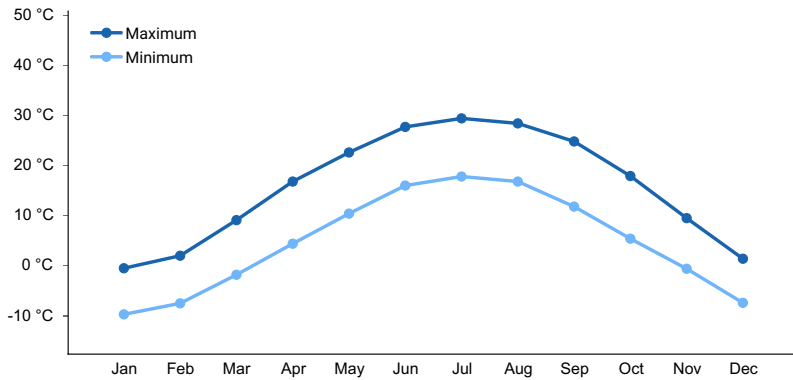

Figure 6. Monthly average minimum and maximum temperature

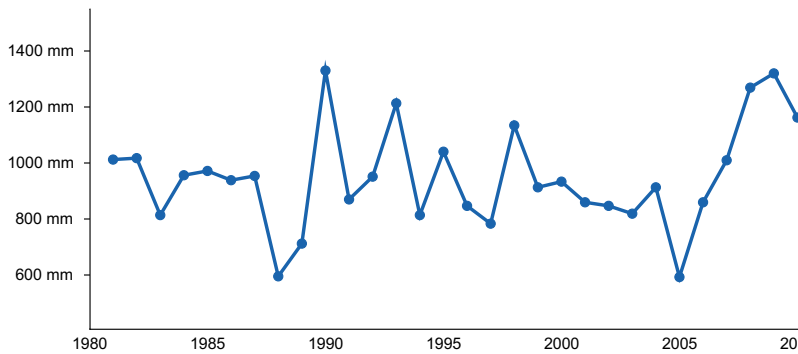

Figure 7. Annual precipitation pattern

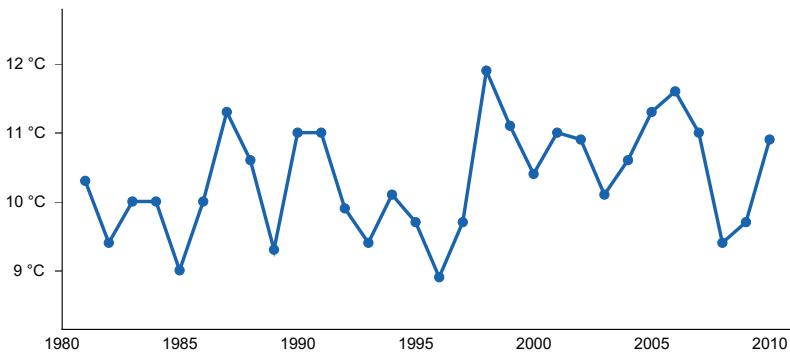

Figure 8. Annual average temperature pattern

Climate stations used

- (1) GENESEO [USC00113384], Geneseo, IL
- (2) ROCHELLE [USC00117354], Rochelle, IL
- (3) MASON CITY 2N [USC00115413], Mason City, IL

Influencing water features

Loamy Outwash Prairies are not influenced by wetland or riparian water features. Precipitation is the main source of water for this ecological site. Infiltration is moderate (Hydrologic Group B), and surface runoff is low to medium. Surface runoff contributes some water to downslope ecological sites (Figure 5).

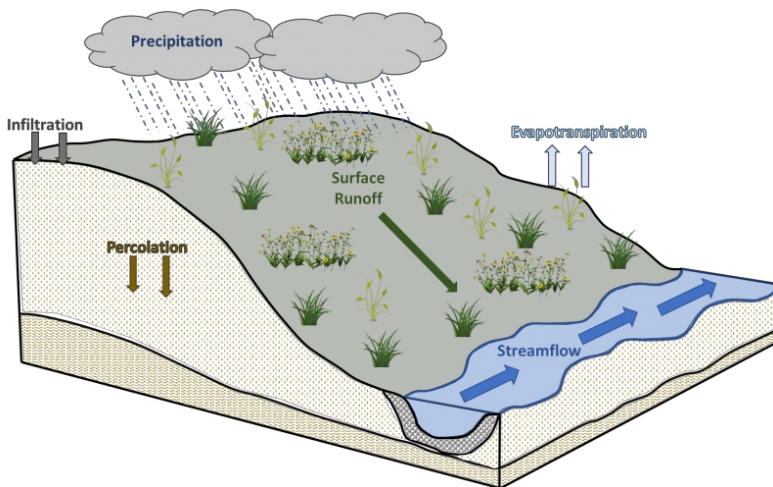

Figure 9. Figure 5. Hydrologic cycling in Loamy Outwash Prairie ecological site.

Soil features

Soils of Loamy Outwash Prairies are in the Mollisols order, further classified as Typic Argiudolls and Typic Hapludolls with moderate infiltration and low to medium runoff potential. The soil series associated with this site includes Coyne, Jasper, Pilot, Waukee, and Waukegan. The parent material is loess or loamy sediments over outwash or loamy lacustrine sediments, and the soils are well-drained and deep. Soil pH classes are very strongly acid to moderately alkaline. No rooting restrictions are noted for the soils of this ecological site (Table 5).

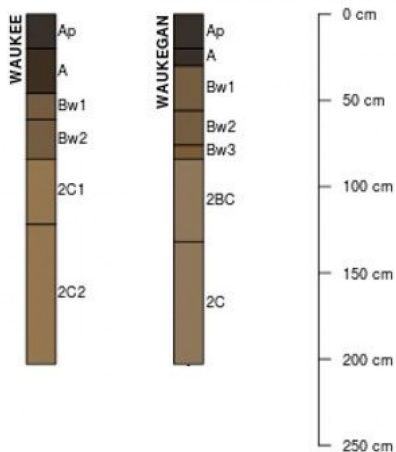

Figure 10. Figure 6. Profile sketches of soil series associated with Loamy Outwash Prairie.

Table 4. Representative soil features

Parent material	(1) Outwash (2) Lacustrine deposits
Family particle size	(1) Coarse-loamy (2) Fine-loamy (3) Fine-loamy over sandy or sandy-skeletal (4) Fine-silty over sandy or sandy-skeletal
Drainage class	Well drained

Permeability class	Slow to moderately slow
Depth to restrictive layer	203 cm
Soil depth	203 cm

Ecological dynamics

The information in this Ecological Site Description, including the state-and-transition model (STM), was developed based on historical data, current field data, professional experience, and a review of the scientific literature. As a result, all possible scenarios or plant species may not be included. Key indicator plant species, disturbances, and ecological processes are described to inform land management decisions.

The MLRA lies within the tallgrass prairie ecosystem of the Midwest. The heterogeneous topography of the area results in variable microclimates and fuel matrices that in support prairies, savannas, and forests. Loamy Outwash Prairies form an aspect of this vegetative continuum. This ecological site occurs on outwash plains and stream terraces on well-drained soils. Species characteristic of this ecological site consist of drought-adapted herbaceous vegetation.

Fire is a critical disturbance factor that maintains Loamy Outwash Prairies. Fire intensity typically consisted of periodic, low-intensity surface fires occurring every 1 to 5 years (LANDFIRE 2009). Ignition sources included summertime lightning strikes from convective storms and bimodal, human ignitions during the spring and fall seasons. Native Americans regularly set fires to improve sight lines for hunting, driving large game, improving grazing and browsing habitat, agricultural clearing, and enhancing vital ethnobotanical plants (Barrett 1980).

Drought and grazing by native ungulates have also played a role in shaping this ecological site. The periodic episodes of reduced soil moisture in conjunction with the well-drained soils have favored the proliferation of plant species tolerant of such conditions. Drought can also slow the growth of plants and result in dieback of certain species. Large mammals, specifically prairie elk (*Cervus elaphus*), bison (*Bos bison*), and white-tailed deer (*Odocoileus virginianus*), likely occurred in low densities resulting in limited impacts to plant composition and dominance (LANDFIRE 2009). When coupled with fire, periods of drought and herbivory can greatly delay the establishment of woody vegetation (Pyne et al. 1996).

Today, Loamy Outwash Prairies are limited in their extent, having been reduced as a result of land conversion to agricultural or livestock production. A return to the historic plant community may not be possible following extensive land modification, but long-term conservation agriculture or prairie reconstruction efforts can help to restore some biotic diversity and ecological function. The state-and-transition model that follows provides a detailed description of each state, community phase, pathway, and transition. This model is based on available experimental research, field observations, literature reviews, professional consensus, and interpretations.

State and transition model

Ecosystem states

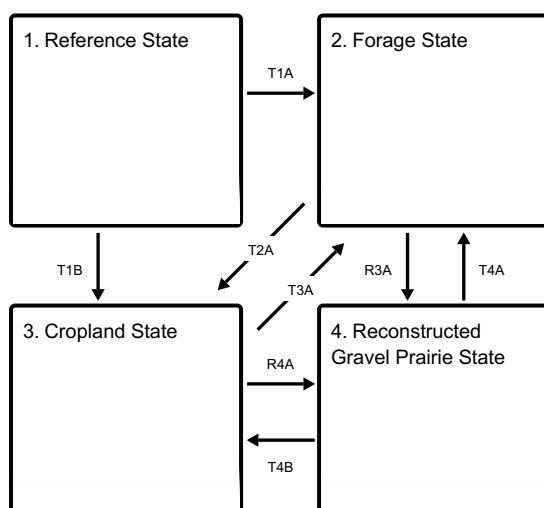

State 1 submodel, plant communities



State 2 submodel, plant communities

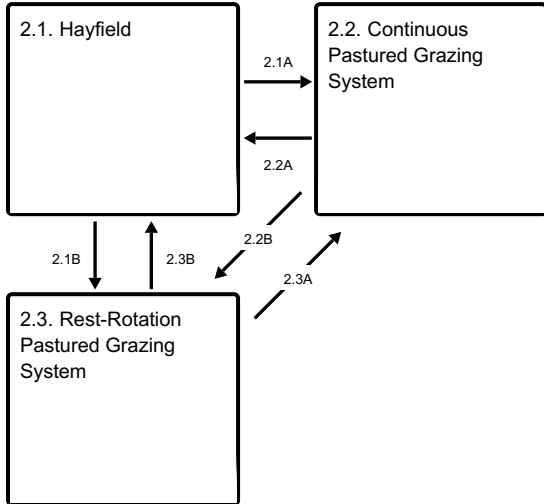

State 3 submodel, plant communities

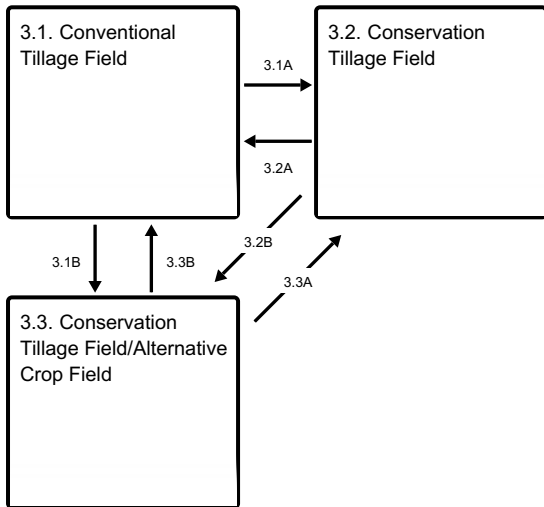

State 4 submodel, plant communities

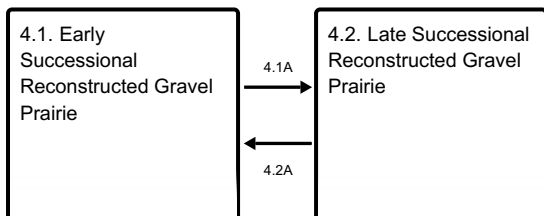

State 1 Reference State

The reference plant community is categorized as a midgrass prairie community, dominated by herbaceous vegetation. The one community phase within the reference state is dependent on fire. Short fire intervals alter species composition, cover, and extent. Drought and grazing have more localized impacts in the reference phases, but do contribute to overall species composition, diversity, cover, and productivity.

Dominant plant species

- little bluestem (*Schizachyrium*), other herbaceous
- sideoats grama (*Bouteloua curtipendula*), other herbaceous

Community 1.1

Little Bluestem – Sideoats Grama

Sites in this reference community phase are dominated by a mix of grasses and forbs. Vegetative cover is patchy to continuous (61 to 100 percent) and plants can reach heights greater than 3 feet tall (LANDFIRE 2009). Little bluestem, sideoats grama, Indiangrass, porcupinegrass, and big bluestem are the dominant grasses. Characteristic forbs can include prairie goldenrod, slimflower scurfpea, and small skullcap (*Scutellaria parvula* Michx.) (White and Madany 1978; NatureServe 2018). Periodic replacement fires every 3 or 4 years will maintain this community phase (LANDFIRE 2009).

Dominant plant species

- little bluestem (*Schizachyrium*), other herbaceous
- sideoats grama (*Bouteloua curtipendula*), other herbaceous

State 2

Forage State

The forage state occurs when the reference state is converted to a farming system that emphasizes domestic livestock production known as grassland agriculture. Fire suppression, periodic cultural treatments (e.g., clipping, drainage, soil amendment applications, planting new species and/or cultivars, mechanical harvesting) and grazing by domesticated livestock transition and maintain this state (USDA-NRCS 2003). Early settlers seeded non-native species, such as smooth brome (*Bromus inermis* Leyss.) and Kentucky bluegrass (*Poa pratensis* L.), to help extend the grazing season. Over time, as lands were continuously harvested or grazed by herds of cattle, the non-native species were able to spread and expand across the landscape, reducing the native species diversity and ecological function.

Community 2.1

Hayfield

Hayfield – Sites in this community phase consist of forage plants that are planted and mechanically harvested. Mechanical harvesting removes much of the aboveground biomass and nutrients that feed the soil microorganisms (Franzluebbers et al. 2000; USDA-NRCS 2003). As a result, soil biology is reduced leading to decreases in nutrient uptake by plants, soil organic matter, and soil aggregation. Frequent biomass removal can also reduce the site's carbon sequestration capacity (Skinner 2008).

Community 2.2

Continuous Pastured Grazing System

Continuous Pastured Grazing System – This community phase is characterized by continuous grazing where domestic livestock graze a pasture for the entire season. Depending on stocking density, this can result in lower forage quality and productivity, weed invasions, and uneven pasture use. Continuous grazing can also increase the amount of bare ground and erosion and reduce soil organic matter, cation exchange capacity, water-holding capacity, and nutrient availability and retention (Bharati et al. 2002; Leake et al. 2004; Teague et al. 2011). Smooth brome, Kentucky bluegrass, and white clover (*Trifolium repens* L.) are common pasture species used in this phase. Their tolerance to continuous grazing has allowed these species to dominate, sometimes completely excluding the native vegetation.

Community 2.3

Rest-Rotation Pastured Grazing System

Rest-Rotation Pastured Grazing System – This community phase is characterized by rotational grazing where the pasture has been subdivided into several smaller paddocks. Through the development of a grazing plan, livestock utilize one or a few paddocks, while the remaining area is rested allowing plants to restore vigor and energy reserves, deepen root systems, develop seeds, as well as allow seedling establishment (Undersander et al. 2002;

USDA-NRCS 2003). Rest-rotation pastured grazing systems include deferred rotation, rest rotation, high intensity – low frequency, and short duration methods. Vegetation is generally more diverse and can include orchardgrass (*Dactylis glomerata* L.), timothy (*Phleum pratense* L.), red clover (*Trifolium pratense* L.), and alfalfa (*Medicago sativa* L.). The addition of native prairie species can further bolster plant diversity and, in turn, soil function. This community phase promotes numerous ecosystem benefits including increasing biodiversity, preventing soil erosion, maintaining and enhancing soil quality, sequestering atmospheric carbon, and improving water yield and quality (USDA-NRCS 2003).

Pathway 2.1A **Community 2.1 to 2.2**

Mechanical harvesting is replaced with domestic livestock utilizing continuous grazing

Pathway 2.1B **Community 2.1 to 2.3**

Mechanical harvesting is replaced with domestic livestock utilizing rotational grazing

Pathway 2.2A **Community 2.2 to 2.1**

Domestic livestock are removed, and mechanical harvesting is implemented

Pathway 2.2B **Community 2.2 to 2.3**

Rotational grazing replaces continuous grazing

Pathway 2.3B **Community 2.3 to 2.1**

Domestic livestock are removed, and mechanical harvesting is implemented

Pathway 2.3A **Community 2.3 to 2.2**

Continuous grazing replaces rotational grazing

State 3 **Cropland State**

The continuous use of tillage, row-crop planting, and chemicals (i.e., herbicides, fertilizers, etc.) has effectively eliminated the reference community and many of its natural ecological functions in favor of crop production. Corn and soybeans are the dominant crops for the site, and oats (*Avena* L.) and alfalfa (*Medicago sativa* L.) may be rotated periodically. These areas are likely to remain in crop production for the foreseeable future. Community Phase 3.1 Conventional Tillage Field – Sites in this community phase typically consist of monoculture row-cropping maintained by conventional tillage practices. They are cropped in either continuous corn or corn-soybean rotations. The frequent use of deep tillage, low crop diversity, and bare soil conditions during the non-growing season negatively impacts soil health. Under these practices, soil aggregation is reduced or destroyed, soil organic matter is reduced, erosion and runoff are increased, and infiltration is decreased, which can ultimately lead to undesirable changes in the hydrology of the watershed (Tomer et al. 2005).

Community 3.1 **Conventional Tillage Field**

Conventional Tillage Field – Sites in this community phase typically consist of monoculture row-cropping maintained by conventional tillage practices. They are cropped in either continuous corn or corn-soybean rotations.

The frequent use of deep tillage, low crop diversity, and bare soil conditions during the non-growing season negatively impacts soil health. Under these practices, soil aggregation is reduced or destroyed, soil organic matter is reduced, erosion and runoff are increased, and infiltration is decreased, which can ultimately lead to undesirable changes in the hydrology of the watershed (Tomer et al. 2005).

Community 3.2 Conservation Tillage Field

Conservation Tillage Field – This community phase is characterized by rotational crop production that utilizes various conservation tillage methods to promote soil health and reduce erosion. Conservation tillage methods include strip-till, ridge-till, vertical-till, or no-till planting systems. Strip-till keeps seedbed preparation to narrow bands less than one-third the width of the row where crop residue and soil consolidation are left undisturbed in-between seedbed areas. Strip-till planting may be completed in the fall and nutrient application either occurs simultaneously or at the time of planting. Ridge-till uses specialized equipment to create ridges in the seedbed and vegetative residue is left on the surface in between the ridges. Weeds are controlled with herbicides and/or cultivation, seedbed ridges are rebuilt during cultivation, and soils are left undisturbed from harvest to planting. Vertical-till systems employ machinery that lightly tills the soil and cuts up crop residue, mixing some of the residue into the top few inches of the soil while leaving a large portion on the surface. No-till management is the most conservative, disturbing soils only at the time of planting and fertilizer application. Compared to conventional tillage systems, conservation tillage methods can improve soil ecosystem function by reducing soil erosion, increasing organic matter and water availability, improving water quality, and reducing soil compaction.

Community 3.3 Conservation Tillage Field/Alternative Crop Field

Conservation Tillage Field/Alternative Crop Field – This community phase applies conservation tillage methods as described above as well as adds cover crop practices. Cover crops typically include nitrogen-fixing species (e.g., legumes), small grains (e.g., rye, wheat, oats), or forage covers (e.g., turnips, radishes, rapeseed). The addition of cover crops not only adds plant diversity but also promotes soil health by reducing soil erosion, limiting nitrogen leaching, suppressing weeds, increasing soil organic matter, and improving the overall soil ecosystem. In the case of small grain cover crops, surface cover and water infiltration are increased, while forage covers can be used to graze livestock or support local wildlife. Of the three community phases for this state, this phase promotes the greatest soil sustainability and improves ecological functioning within a cropland system.

Pathway 3.1A Community 3.1 to 3.2

Tillage operations are greatly reduced, crop rotation occurs on a regular interval, and crop residue remains on the soil surface

Pathway 3.1B Community 3.1 to 3.3

Tillage operations are greatly reduced or eliminated, crop rotation occurs on a regular interval, crop residue remains on the soil surface, and cover crops are planted following crop harvest

Pathway 3.2A Community 3.2 to 3.1

Intensive tillage is utilized, and monoculture row-cropping is established

Pathway 3.2B Community 3.2 to 3.3

Cover crops are implemented to minimize soil erosion

Pathway 3.3B

Community 3.3 to 3.1

Intensive tillage is utilized, cover crops practices are abandoned, monoculture row-cropping is established, and crop rotation is reduced or eliminated

Pathway 3.3A

Community 3.3 to 3.2

Cover crop practices are abandoned

State 4

Reconstructed Gravel Prairie State

Prairie reconstructions have become an important tool for repairing natural ecological functions and providing habitat protection for numerous grassland dependent species. Because the historic plant and soil biota communities of the tallgrass prairie were highly diverse with complex interrelationships, historic prairie replication cannot be guaranteed on landscapes that have been so extensively manipulated for extended timeframes (Kardol and Wardle 2010; Fierer et al. 2013). Therefore, ecological restoration should aim to aid the recovery of degraded, damaged, or destroyed ecosystems. A successful restoration will have the ability to structurally and functionally sustain itself, demonstrate resilience to the natural ranges of stress and disturbance, and create and maintain positive biotic and abiotic interactions (SER 2002). The reconstructed prairie state is the result of a long-term commitment involving a multi-step, adaptive management process. Diverse, species-rich seed mixes are important to utilize as they allow the site to undergo successional stages that exhibit changing composition and dominance over time (Smith et al. 2010). On-going management via prescribed fire and/or light grazing can help the site progress from an early successional community dominated by annuals and some weeds to a later seral stage composed of native, perennial grasses, forbs, and a few shrubs. Establishing a prescribed fire regimen that mimics natural disturbance patterns can increase native species cover and diversity while reducing cover of non-native forbs and grasses. Light grazing alone can help promote species richness, while grazing accompanied with fire can control the encroachment of woody vegetation (Brudvig et al. 2007).

Community 4.1

Early Successional Reconstructed Gravel Prairie

Early Successional Reconstructed Gravel Prairie – This community phase represents the early community assembly from prairie reconstruction and is highly dependent on the seed mix utilized and the timing and priority of planting operations. The seed mix should look to include a diverse mix of cool-season and warm-season annual and perennial grasses and forbs typical of the reference state (e.g., little bluestem, porcupinegrass, slimflower scurfpea). Cool-season annuals can help provide litter that promotes cool, moist soil conditions to the benefit of the other species in the seed mix. The first season following site preparation and seeding will typically result in annuals and other volunteer species forming a majority of the vegetative cover. Control of non-native species, particularly perennial species, is crucial at this point to ensure they do not establish before the native vegetation (Martin and Wilsey 2012). After the first season, native warm-season grasses should begin to become more prominent on the landscape.

Community 4.2

Late Successional Reconstructed Gravel Prairie

Late Successional Reconstructed Gravel Prairie – Appropriately timed disturbance regimes (e.g., prescribed fire) applied to the early successional community phase can help increase the beta diversity, pushing the site into a late successional community phase over time. While prairie communities are dominated by grasses, these species can suppress forb establishment and reduce overall diversity and ecological function (Martin and Wilsey 2006; Williams et al. 2007). Reducing accumulated plant litter from perennial bunchgrasses allows more light and nutrients to become available for forb recruitment, allowing greater ecosystem complexity (Wilsey 2008).

Pathway 4.1A

Community 4.1 to 4.2

Selective herbicides are used to control non-native species, and prescribed fire and/or light grazing helps to increase the native species diversity and control woody vegetation.

Pathway 4.2A

Community 4.2 to 4.1

Reconstruction experiences a decrease in native species diversity from drought or improper timing of management actions (e.g., reduced fire frequency, use of non-selective herbicides).

Transition T1A

State 1 to 2

Cultural treatments to enhance forage quality and yield transitions the site to the forage state

Transition T1B

State 1 to 3

Tillage, seeding of agricultural crops, and non-selective herbicide transition the site to the cropland state

Transition T2A

State 2 to 3

Tillage, seeding of agricultural crops, and non-selective herbicide transition this site to the cropland state

Transition R3A

State 2 to 4

Site preparation, invasive species control, and seeding native species transition this site to the reconstructed gravel prairie state

Restoration pathway T3A

State 3 to 2

Cultural treatments to enhance forage quality and yield transitions the site to the forage state

Transition R4A

State 3 to 4

Site preparation, invasive species control, and seeding native species transition this site to the reconstructed gravel prairie state

Restoration pathway T4A

State 4 to 2

Cultural treatments to enhance forage quality and yield transition the site to the forage state

Restoration pathway T4B

State 4 to 3

Tillage, seeding of agricultural crops, and non-selective herbicide transition this site to the cropland state

Additional community tables

Inventory data references

No field plots have been developed for this site. A review of the scientific literature and professional experience

were used to approximate the plant communities for this provisional ecological site. Information for the state-and-transition model was obtained from the same sources. All community phases are considered provisional based on these plots and the sources identified in this ecological site description.

Other references

Angel, J. No date. Climate of Illinois Narrative. Illinois State Water Survey, Prairie Research Institute, University of Illinois at Urbana-Champaign. Available at <https://www.isws.illinois.edu/statecli/General/Illinois-climate-narrative.htm>. Accessed 8 November 2018.

Barrett, S.W. 1980. Indians and fire. *Western Wildlands* Spring: 17-20.

Bharati, L., K.-H. Lee, T.M. Isenhardt, and R.C. Schultz. 2002. Soil-water infiltration under crops, pasture, and established riparian buffer in Midwestern USA. *Agroforestry Systems* 56: 249-257.

Brudvig, L.A., C.M. Mabry, J.R. Miller, and T.A. Walker. 2007. Evaluation of central North American prairie management based on species diversity, life form, and individual species metrics. *Conservation Biology* 21:864-874.

Cleland, D.T., J.A. Freeouf, J.E. Keys, G.J. Nowacki, C. Carpenter, and W.H. McNab. 2007. Ecological Subregions: Sections and Subsections of the Conterminous United States. USDA Forest Service, General Technical Report WO-76. Washington, DC. 92 pps.

Franzluebbers, A.J., J.A. Stuedemann, H.H. Schomberg, and S.R. Wilkinson. 2000. Soil organic C and N pools under long-term pasture management in the Southern Piedmont USA. *Soil Biology and Biochemistry* 32:469-478.

Fierer, N., J. Ladau, J.C. Clemente, J.W. Leff, S.M. Owens, K.S. Pollard, R. Knight, J.A. Gilbert, and R.L. McCulley. 2013. Reconstructing the microbial diversity and function of pre-agricultural tallgrass prairie soils in the United States. *Science* 342: 621-624.

Kardol, P. and D.A. Wardle. 2010. How understanding aboveground-belowground linkages can assist restoration ecology. *Trends in Ecology and Evolution* 25: 670-679.

LANDFIRE. 2009. Biophysical Setting 4214120 North-Central Interior Sand and Gravel Tallgrass Prairie. In: LANDFIRE National Vegetation Dynamics Models. USDA Forest Service and US Department of Interior. Washington, DC.

Leake, J., D. Johnson, D. Donnelly, G. Muckle, L. Boddy, and D. Read. 2004. Networks of power and influence: the role of mycorrhizal mycelium in controlling plant communities and agroecosystem functioning. *Canadian Journal of Botany* 82: 1016-1045.

Martin, L.M. and B.J. Wilsey. 2006. Assessing grassland restoration success: relative roles of seed additions and native ungulate activities. *Journal of Applied Ecology* 43: 1098-1110.

Martin, L.M. and B.J. Wilsey. 2012. Assembly history alters alpha and beta diversity, exotic-native proportions and functioning of restored prairie plant communities. *Journal of Applied Ecology* 49: 1436-1445.

NatureServe. 2018. NatureServe Explorer: An online encyclopedia of life [web application]. Version 7.1 NatureServe, Arlington, VA. Available at <http://explorer.natureserve.org>. (Accessed 13 February 2019).

Peel, M.C., B.L. Finlayson, and T.A. McMahon. 2007. Updated world map of the Köppen-Geiger climate classification. *Hydrology and Earth System Sciences* 11: 1633-1644.

Schwegman, J.E., G.B. Fell, M. Hutchinson, G. Paulson, W.M. Shepherd, and J. White. 1973. Comprehensive Plan for the Illinois Nature Preserves System, Part 2 The Natural Divisions of Illinois. Illinois Nature Preserves Commission, Rockford, IL. 32 pps.

Skinner, R.H. 2008. High biomass removal limits carbon sequestration potential of mature temperate pastures.

Journal for Environmental Quality 37: 1319-1326.

Smith, D.D., D. Williams, G. Houseal, and K. Henderson. 2010. The Tallgrass Prairie Center Guide to Prairie Restoration in the Upper Midwest. University of Iowa Press, Iowa City, IA. 338 pps.

Society for Ecological Restoration [SER]. Science & Policy Working Group. 2002. The SER Primer on Ecological Restoration. Available at: <http://www.ser.org/>. (Accessed 28 February 2017).

Taft, J.B., G.S. Wilhelm, D.M. Ladd, and L.A. Masters. 1997. Floristic Quality Assessment for vegetation in Illinois, a method for assessing vegetation integrity. *Erigenia* 15: 3-95.

Taft, J.B., R.C. Anderson, L.R. Iverson, and W.C. Handel. 2009. Chapter 4: Vegetation ecology and change in terrestrial ecosystems. In: C.A. Taylor, J.B. Taft, and C.E. Warwick (eds.). *Canaries in the Catbird Seat: The Past, Present, and Future of Biological Resources in a Changing Environment*. Illinois Natural Heritage Survey Special Publication 30, Prairie Research Institute, University of Illinois at Urbana-Champaign. 306 pps.

Teague, W.R., S.L. Dowhower, S.A. Baker, N. Haile, P.B. DeLaune, and D.M. Conover. 2011. Grazing management impacts on vegetation, soil biota and soil chemical, physical and hydrological properties in tall grass prairie. *Agriculture, Ecosystems and Environment* 141: 310-322.

Tomer, M.D., D.W. Meek, and L.A. Kramer. 2005. Agricultural practices influence flow regimes of headwater streams in western Iowa. *Journal of Environmental Quality* 34:1547-1558.

Undersander, D., B. Albert, D. Cosgrove, D. Johnson, and P. Peterson. 2002. *Pastures for Profit: A Guide to Rotational Grazing (A3529)*. University of Wisconsin-Extension and University of Minnesota Extension Service. 43 pps.

United States Department of Agriculture – Natural Resources Conservation Service (USDA-NRCS). 2003. *National Range and Pasture Handbook, Revision 1*. Grazing Lands Technology Institute. 214 pps.

United States Department of Agriculture – Natural Resource Conservation Service (USDA-NRCS). 2006. *Land Resource Regions and Major Land Resource Areas of the United States, the Caribbean, and the Pacific Basin*. U.S. Department of Agriculture Handbook 296. 682 pps.

U.S. Environmental Protection Agency [EPA]. 2013. *Level III and Level IV Ecoregions of the Continental United States*. Corvallis, OR, U.S. EPA, National Health and Environmental Effects Research Laboratory, map scale 1:3,000,000. Available at <http://www.epa.gov/eco-research/level-iii-and-iv-ecoregions-continental-united-states>. (Accessed 1 March 2017).

White, J. and M.H. Madany. 1978. Classification of natural communities in Illinois. In: J. White. *Illinois Natural Areas Inventory Technical Report*. Illinois Natural Areas Inventory, Department of Landscape Architecture, University of Illinois at Urbana/Champaign. 426 pps.

Williams, D.A., L.L. Jackson, and D.D. Smith. 2007. Effects of frequent mowing on survival and persistence of forbs seeded into a species-poor grassland. *Restoration Ecology* 15: 24-33.

Wilsey, B.J. 2008. Productivity and subordinate species response to dominant grass species and seed source during restoration. *Restoration Ecology* 18: 628-637.

Contributors

Lisa Kluesner
Rick Francen

Approval

Chris Tecklenburg, 5/27/2020

Acknowledgments

This project could not have been completed without the dedication and commitment from a variety of staff members (Table 6). Team members supported the project by serving on the technical team, assisting with the development of state and community phases of the state-and-transition model, providing peer review and technical editing, and conducting quality control and quality assurance reviews.

Natural Resources Conservation Service :

Scott Brady, Acting Regional Ecological Site Specialist, Havre, MT

Stacey Clark, Regional Ecological Site Specialist, St. Paul, MN

Tonie Endres, Senior Regional Soil Scientist, Indianapolis, IN

Rick Francen, Soil Scientist, Springfield, IL

John Hammerly, Soil Data Quality Specialist, Indianapolis, IN

Frank Heisner, Resource Soil Scientist, Morrison, IL

Lisa Kluesner, Ecological Site Specialist, Waverly, IA

Kevin Norwood, Soil Survey Regional Director, Indianapolis, IN

Bob Tegeler, MLRA Soil Survey Leader, Springfield, IL

Rangeland health reference sheet

Interpreting Indicators of Rangeland Health is a qualitative assessment protocol used to determine ecosystem condition based on benchmark characteristics described in the Reference Sheet. A suite of 17 (or more) indicators are typically considered in an assessment. The ecological site(s) representative of an assessment location must be known prior to applying the protocol and must be verified based on soils and climate. Current plant community cannot be used to identify the ecological site.

Author(s)/participant(s)	
Contact for lead author	
Date	05/07/2024
Approved by	Chris Tecklenburg
Approval date	
Composition (Indicators 10 and 12) based on	Annual Production

Indicators

1. **Number and extent of rills:**

2. **Presence of water flow patterns:**

3. **Number and height of erosional pedestals or terracettes:**

4. **Bare ground from Ecological Site Description or other studies (rock, litter, lichen, moss, plant canopy are not bare ground):**

5. **Number of gullies and erosion associated with gullies:**

6. **Extent of wind scoured, blowouts and/or depositional areas:**

7. **Amount of litter movement (describe size and distance expected to travel):**

8. **Soil surface (top few mm) resistance to erosion (stability values are averages - most sites will show a range of values):**

9. **Soil surface structure and SOM content (include type of structure and A-horizon color and thickness):**

10. **Effect of community phase composition (relative proportion of different functional groups) and spatial distribution on infiltration and runoff:**

11. **Presence and thickness of compaction layer (usually none; describe soil profile features which may be mistaken for compaction on this site):**

12. **Functional/Structural Groups (list in order of descending dominance by above-ground annual-production or live foliar cover using symbols: >>, >, = to indicate much greater than, greater than, and equal to):**

Dominant:

Sub-dominant:

Other:

Additional:

13. **Amount of plant mortality and decadence (include which functional groups are expected to show mortality or decadence):**

14. **Average percent litter cover (%) and depth (in):**

15. **Expected annual annual-production (this is TOTAL above-ground annual-production, not just forage annual-production):**

16. **Potential invasive (including noxious) species (native and non-native). List species which BOTH characterize degraded states and have the potential to become a dominant or co-dominant species on the ecological site if their future establishment and growth is not actively controlled by management interventions. Species that become dominant for only one to several years (e.g., short-term response to drought or wildfire) are not invasive plants. Note that unlike other indicators, we are describing what is NOT expected in the reference state**

for the ecological site:

17. **Perennial plant reproductive capability:**
