

Ecological site F115XA016IL

Wet Muck

Last updated: 12/30/2024
Accessed: 01/10/2025

General information

Provisional. A provisional ecological site description has undergone quality control and quality assurance review. It contains a working state and transition model and enough information to identify the ecological site.

MLRA notes

Major Land Resource Area (MLRA): 115X–Central Mississippi Valley Wooded Slopes

This MLRA is characterized by deeply dissected, loess-covered hills bordering well defined valleys of the Illinois, Mississippi, Missouri, Ohio, and Wabash Rivers and their tributaries. It is used to produce cash crops and livestock. About one-third of the area is forested, mostly on the steeper slopes. This area is in Illinois (50 percent), Missouri (36 percent), Indiana (13 percent), and Iowa (1 percent) in two separate areas. It makes up about 25,084 square miles (64,967 square kilometers).

Most of this area is in the Till Plains section and the Dissected Till Plains section of the Central Lowland province of the Interior Plains. The Springfield-Salem plateaus section of the Ozarks Plateaus province of the Interior Highlands occurs along the Missouri River and the Mississippi River south of the confluence with the Missouri River. The nearly level to very steep uplands are dissected by both large and small tributaries of the Illinois, Mississippi, Missouri, Ohio, and Wabash Rivers. The Ohio River flows along the southernmost boundary of this area in Indiana. Well defined valleys with broad flood plains and numerous stream terraces are along the major streams and rivers. The flood plains along the smaller streams are narrow. Broad summits are nearly level to undulating. Karst topography is common in some parts along the Missouri and Mississippi Rivers and their tributaries. Well-developed karst areas have hundreds of sinkholes, caves, springs, and losing streams. In the St. Louis area, many of the karst features have been obliterated by urban development.

Elevation ranges from 90 feet (20 meters) on the southernmost flood plains to 1,030 feet (320 meters) on the highest ridges. Local relief is mainly 10 to 50 feet (3 to 15 meters) but can be 50 to 150 feet (15 to 45 meters) in the steep, deeply dissected hills bordering rivers and streams. The bluffs along the major rivers are generally 200 to 350 feet (60 to 105 meters) above the valley floor.

The uplands in this MLRA are covered almost entirely with Peoria Loess. The loess can be more than 7 feet (2 meters) thick on stable summits. On the steeper slopes, it is thin or does not occur. In Illinois, the loess is underlain mostly by Illinoian-age till that commonly contains a paleosol. Pre-Illinoian-age till is in parts of this MLRA in Iowa and Missouri and to a minor extent in the western part of Illinois. Wisconsin-age outwash, alluvial deposits, and sandy eolian material are on some of the stream terraces and on dunes along the major tributaries. The loess and glacial deposits are underlain by several bedrock systems. Pennsylvanian and Mississippian bedrock are the most extensive. To a lesser extent are Silurian, Devonian, Cretaceous, and Ordovician bedrock. Karst areas have formed where limestone is near the surface, mostly in the southern part of the MLRA along the Mississippi River and some of its major tributaries. Bedrock outcrops are common on the bluffs along the Mississippi, Ohio, and Wabash Rivers and their major tributaries and at the base of some steep slopes along minor streams and drainageways.

The annual precipitation ranges from 35 to 49 inches (880 to 1,250 millimeters) with a mean of 41 inches (1,050 millimeters). The annual temperature ranges from 48 to 58 degrees F (8.6 to 14.3 degrees C) with a mean of 54 degrees F (12.3 degrees C). The freeze-free period ranges from 150 to 220 days with a mean of 195 days.

Soils The dominant soil orders are Alfisols and, to a lesser extent, Entisols and Mollisols. The soils in the area have

a mesic soil temperature regime, an aquic or udic soil moisture regime, and mixed or smectitic mineralogy. They are shallow to very deep, excessively drained to poorly drained, and loamy, silty, or clayey.

The soils on uplands in this area support natural hardwoods. Oak, hickory, and sugar maple are the dominant species. Big bluestem, little bluestem, and scattered oak and eastern redcedar grow on some sites. The soils on flood plains support mixed forest vegetation, mainly American elm, eastern cottonwood, river birch, green ash, silver maple, sweetgum, American sycamore, pin oak, pecan, and willow. Sedge and grass meadows and scattered trees are on some low-lying sites. (United States Department of Agriculture, Natural Resources Conservation Service, 2022)

LRU notes

Most of this LRU (Land Resource Unit) is in the glaciated Till Plains Section of the Central Lowland Province of the Interior Plains. The southeast corner is in the Highland Rim Section (locally known as the Shawnee Hills Section) of the Interior Low Plateaus Province of the Interior Plains. The nearly level to very steep uplands in this LRU are dissected by both large and small tributaries of the Wabash and Ohio Rivers. Well defined valleys with broad flood plains and numerous stream terraces are along the major streams and rivers. The flood plains along the smaller streams are narrow. Broad summits are nearly level to gently sloping.

This area is covered almost entirely with Wisconsin loess. The loess can be more than 7 feet (2 meters) thick on stable summits. On the steeper slopes, it is thin or does not occur. The loess throughout the area is underlain dominantly by glacial till. Wisconsin outwash, alluvial deposits, and sandy eolian material are on some of the stream terraces and on dunes along the major tributaries in the area. The loess and glacial drift are underlain by Pennsylvanian-age bedrock. Bedrock outcrops are common in the walls of the valleys along the Wabash and Ohio Rivers and at the base of some steep slopes along minor streams and drainageways.

The dominant soil orders in this LRU are Alfisols, Entisols, Inceptisols, and Mollisols. The soils in the area have a mesic soil temperature regime, a udic or aquic soil moisture regime, and dominantly mixed or smectitic mineralogy. The soils are very deep, poorly drained to excessively drained, and loamy, silty, or clayey. Nearly level Endoaqualfs (Iva series) and Argiaquolls (Ragsdale series) formed in loess on broad upland summits and flats. Nearly level to steep Hapludalfs (Alford, Iona, Muren, Stoy, and Sylvan series) and Fragiudalfs (Hosmer series) formed in loess on uplands. Hapludalfs (Alvin, Bloomfield, and Princeton series) and Argiudolls (Ade series) formed in sandy eolian material in areas of dunes on uplands and stream terraces. Steep and very steep Hapludalfs (Hickory series) formed in Illinoian till along the major streams and dissected upland drainageways. Hapludalfs (Wellston series) formed in siltstone or sandstone residuum on strongly sloping to steep side slopes underlain by bedrock.

The soils in the major stream valleys include Hapludolls (Carmi series), Argiudolls (Elston series), and Hapludalfs (Skelton series), all of which formed in outwash on nearly level to moderately sloping stream terraces and outwash plains. Endoaquolls (Montgomery series), Endoaquepts (Zipp series), Epiaqualfs (McGary series), and Hapludalfs (Shircliff and Markland series) formed in clayey lacustrine sediments on nearly level to strongly sloping lacustrine terraces or lake plains. Endoaquepts (Evansville series), Endoaquolls (Patton series), and Hapludalfs (Henshaw and Uniontown series) formed in silty sediments on terraces and lake plains.

LRU notes (excerpts from Land resource regions and major land resource areas of the United States, the Caribbean, and the Pacific Basin. USDA Handbook 296, 2006)

Classification relationships

Major Land Resource Area (MLRA) 115X–Central Mississippi Valley Wooded Slopes

U.S. Forest Service Ecoregions (Cleland et al. 2007):

Domain: Humid Temperate Domain

Division: Hot Continental Division

Province: Eastern Broadleaf Forest (Continental)

Province Code: 222

Section Code: 222G, 222D

Ecological site concept

The reference site is found on very deep, very poorly drained soils formed in alluvium overlying organic soil material. The reference community is a deciduous swamp with species such as swamp cotton wood (*Populus heterophylla*), bald cypress (*Taxodium distichum*), and swamp red maple or Drummond's maple (*Acer rubrum* L. var. *drummondii*). Shrubs include wet-tolerant species such as willows (*Salix* spp.), dogwoods (*Cornus* spp.), swamp rose (*Rosa palustris*), and buttonbush (*Cephalanthus occidentalis*). Shallow border zones will include native herbaceous species such as sensitive fern (*Onoclea sensibilis*) and lizard's tongue (*Saururus cernuus*).

Logging and hydrological modifications (levees, ditching, tiling) have directly or indirectly impacted many remaining wooded sites. Disturbed sites often include wet tolerant, fast growing trees such as maples, ashes, elms, dogwoods, and willows.

Associated sites

F115XA014IL	Wet Silty Floodplain Wet Silty Floodplain. These sites are on floodplains and are formed in silty alluvium.
F115XA018IL	Wet Clayey Floodplain Wet Clayey Floodplain. These sites are on floodplains and are formed in clayey alluvium.

Table 1. Dominant plant species

Tree	(1) <i>Populus heterophylla</i> (2) <i>Taxodium distichum</i>
Shrub	(1) <i>Cephalanthus occidentalis</i> (2) <i>Rosa palustris</i>
Herbaceous	(1) <i>Saururus cernuus</i> (2) <i>Ranunculus flabellaris</i>

Physiographic features

Wet muck sites are located on floodplains. Elevations in LRU 115XA range from 341' – 699'. Sites are often influenced by flooding and/or ponding and a wet layer near the surface. Permeability is impermeable to moderately slow, and runoff class is negligible. The soil Walkkill makes up this group and it is mapped in Knox County, Indiana and Gallatin County, IL.

Table 2. Representative physiographic features

Landforms	(1) Valley > Flood plain
Runoff class	Medium to negligible
Flooding frequency	None to frequent
Ponding frequency	None to occasional
Elevation	104–213 m
Slope	0–2%
Water table depth	0–15 cm
Aspect	Aspect is not a significant factor

Climatic features

About 60 percent of the precipitation falls during the freeze-free period. Most of the rainfall occurs as high-intensity, convective thunderstorms in summer. Snowfall is common in winter. The frost-free period generally ranges from 171-179 days and the freeze-free period generally ranges from 192-199 days.

The following information is based on data taken from weather stations within MLRA 115X as provided in EDIT.

Table 3. Representative climatic features

Frost-free period (characteristic range)	171-179 days
Freeze-free period (characteristic range)	192-199 days
Precipitation total (characteristic range)	1,118-1,194 mm
Frost-free period (actual range)	166-180 days
Freeze-free period (actual range)	190-204 days
Precipitation total (actual range)	1,016-1,219 mm
Frost-free period (average)	175 days
Freeze-free period (average)	196 days
Precipitation total (average)	1,143 mm

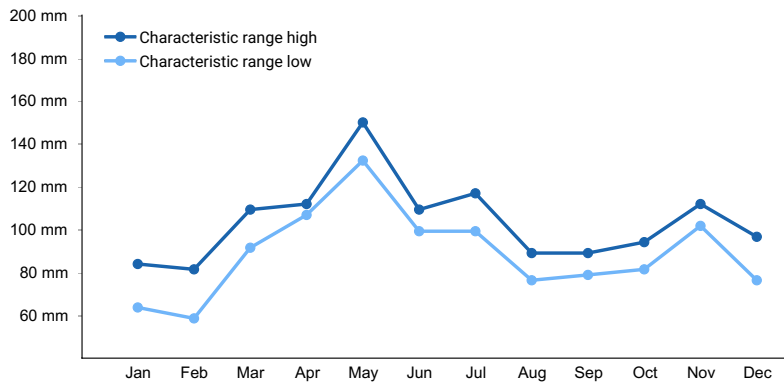

Figure 1. Monthly precipitation range

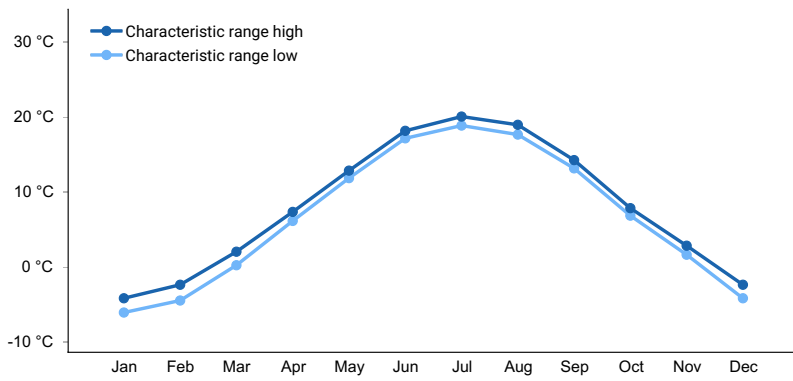

Figure 2. Monthly minimum temperature range

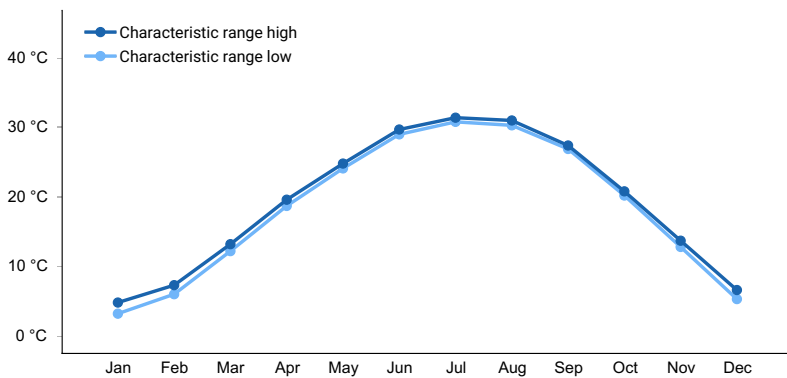

Figure 3. Monthly maximum temperature range

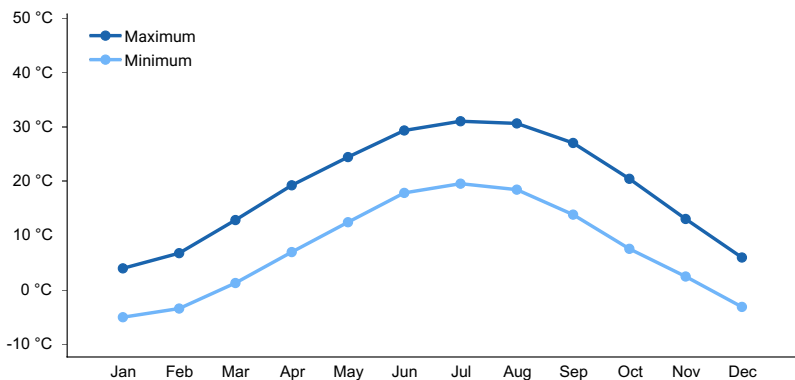

Figure 4. Monthly average minimum and maximum temperature

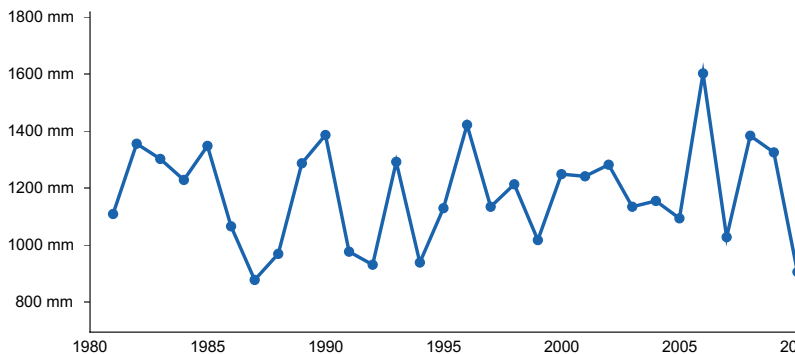

Figure 5. Annual precipitation pattern

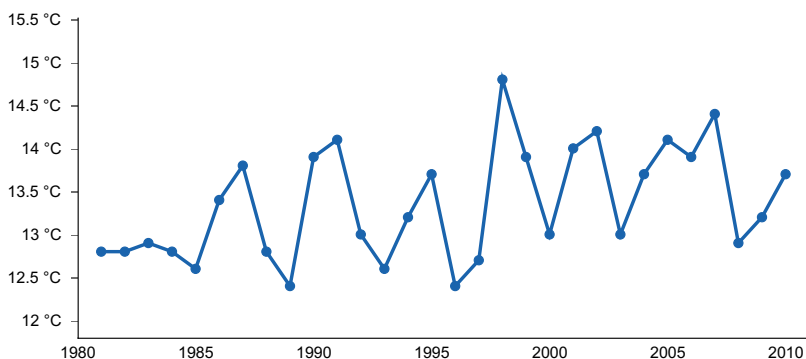

Figure 6. Annual average temperature pattern

Climate stations used

- (1) TERRE HAUTE CAA AP [USW00093823], Terre Haute, IN
- (2) VINCENNES 5 NE [USC00129113], Vincennes, IN
- (3) PRINCETON 1 W [USC00127125], Princeton, IN
- (4) EVANSVILLE REGIONAL AP [USW00093817], Evansville, IN
- (5) MT VERNON [USC00126001], Uniontown, IN

Influencing water features

These sites may be influenced by both flooding and ponding. Flooding ranges from none to frequent and the wet layer depth is often at the surface. Ponding for these sites ranges from none to occasional.

Soil features

The soil series associated with this site is Walkkill. It is mapped in Knox County, Indiana and Gallatin County, IL within LRU 115XA. These soils are very deep, and very poorly drained. Runoff is negligible, flooding is frequent to none, ponding is occasional and permeability ranges from moderately slow to impermeable.

Table 4. Representative soil features

Parent material	(1) Alluvium (2) Organic material
Surface texture	(1) Silt loam
Drainage class	Very poorly drained
Permeability class	Very slow to moderately slow
Soil depth	152–203 cm
Surface fragment cover <=3"	0%
Surface fragment cover >3"	0%
Available water capacity (Depth not specified)	17.78–33.02 cm
Calcium carbonate equivalent (Depth not specified)	0–90%
Electrical conductivity (Depth not specified)	0 mmhos/cm
Soil reaction (1:1 water) (Depth not specified)	5.1–7.8
Subsurface fragment volume <=3" (Depth not specified)	0%
Subsurface fragment volume >3" (Depth not specified)	0%

Ecological dynamics

The Reference State is a swampy deciduous forest with seasonally fluctuating water levels and a diverse vegetative community. Common species on these sites historically included swamp cotton wood (*Populus heterophylla*), bald cypress (*Taxodium distichum*), swamp red maple or Drummond's maple (*Acer rubrum* L. var. *drummondii*), willows (*Salix* spp.), dogwoods (*Cornus* spp.), swamp rose (*Rosa palustris*), and buttonbush (*Cephalanthus occidentalis*). The understory composition and density will vary depending on length and frequency of flooding, length and depth of ponding, and microtopography.

Invasive species can be a management issue on these sites, especially post-disturbance. Purple loosestrife (*Lythrum salicaria* L.) and common reed (*Phragmites australis*) are common invasives.

Some sites have been drained and converted to agricultural uses including row crops and forage production. Levees, ditching, and/or tiling is used to control ponding and improve drainage. Corn and soybeans are a common row crop while cool-season grasses, such as tall fescue and brome are grown for pasture or hay.

State and transition model

Ecosystem states

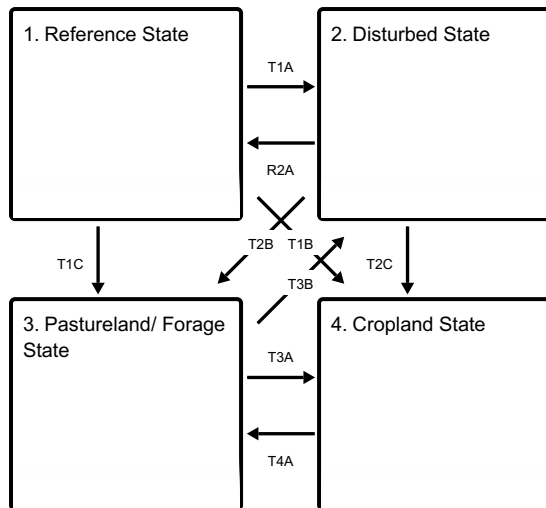

T1A - Large scale disturbance

T1C - Clearing of site; agricultural production - forage

T1B - Clearing of site; agricultural production - row crops.

R2A - Restoration inputs such as planting, brush control, prescribed fire, and timber stand improvement.

T2B - Clearing; agricultural production - forage

T2C - Clearing; agricultural production - row crops

T3B - Abandonment of agricultural practices

T3A - Site preparation, drainage improvements, seeding, weed control, cropland management

T4A - Transition site to forage production; seeding; weed/brush control; pasture management

State 1 submodel, plant communities

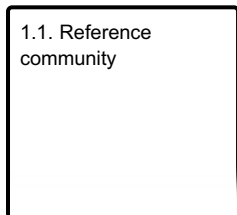

State 2 submodel, plant communities

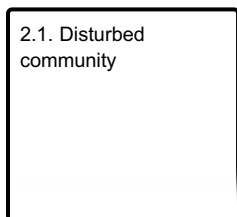

State 3 submodel, plant communities



State 4 submodel, plant communities

4.1. Cropland community

State 1 Reference State

The reference site is a deciduous forest swamp on very poorly drained soils that have formed in alluvium overlying organic soil material. Organic soil portion is high to very high. Common species include bald cypress (*Taxodium distichum*), swamp cottonwood (*Populus heterophylla*), swamp red maple (*Acer rubrum drummondii*), black willow (*Salix nigra*), swamp rose (*Rosa palustris*), and common buttonbush (*Cephalanthus occidentalis*). Microtopography, ponding, and subtle drainage differences will form a mosaic of wet-tolerant species throughout the site.

Dominant plant species

- swamp cottonwood (*Populus heterophylla*), tree
- bald cypress (*Taxodium distichum*), tree
- common buttonbush (*Cephalanthus occidentalis*), shrub
- willow (*Salix*), shrub
- swamp rose (*Rosa palustris*), shrub
- lizard's tail (*Saururus cernuus*), other herbaceous

Community 1.1 Reference community

The reference community is a deciduous swamp with species such as swamp cotton wood (*Populus heterophylla*), bald cypress (*Taxodium distichum*), and swamp red maple or Drummond's maple (*Acer rubrum* L. var. *drummondii*). Shrubs include wet-tolerant species such as willows (*Salix* spp.), dogwoods (*Cornus* spp.), swamp rose (*Rosa palustris*), and buttonbush (*Cephalanthus occidentalis*). Shallow border zones will include native herbaceous species such as sensitive fern (*Onoclea sensibilis*) and lizard's tongue (*Saururus cernuus*).

Dominant plant species

- swamp cottonwood (*Populus heterophylla*), tree
- bald cypress (*Taxodium distichum*), tree
- common buttonbush (*Cephalanthus occidentalis*), shrub
- black willow (*Salix nigra*), shrub
- swamp rose (*Rosa palustris*), shrub
- lizard's tail (*Saururus cernuus*), other herbaceous

State 2 Disturbed State

The Disturbed State is highly variable with regard to species composition and density depending on the type, length, and severity of disturbance. Hydrological modifications (tiling/ditching) will alter the natural hydrology and associated species. Sites that are cleared then abandoned or logged will have a successional community of saplings, shrubs, and herbaceous vegetation. Diversity of species may also be reduced, especially if there has been an introduction of non-native species which is common.

Dominant plant species

- maple (*Acer*), tree
- ash (*Fraxinus*), tree
- elm (*Ulmus*), tree
- willow (*Salix*), shrub

- common buttonbush (*Cephalanthus occidentalis*), shrub

Community 2.1

Disturbed community

Most remaining natural sites have been altered due to clearing and/or hydrological modifications in the watershed. Trees on site, will depending on the type, length and severity of disturbances and the current hydrology. Depending on the changes to drainage, common species may include red maple, silver maple, elm, and green ash. Sites that have had been logged will display a post-disturbance increase in shrub density. Diversity of species may also be reduced, especially if there has been an introduction of non-native species. Many highly disturbed sites are eventually transitioned to Pastureland (State 3) or cropland (State 4).

Dominant plant species

- maple (*Acer*), tree
- ash (*Fraxinus*), tree
- elm (*Ulmus*), tree
- willow (*Salix*), shrub
- common buttonbush (*Cephalanthus occidentalis*), shrub

State 3

Pastureland/ Forage State

A portion of these sites have been converted to pastureland or forage production. Species selection will depend upon the objectives and goals of the landowner; however, commonly planted grasses include tall fescue (*Schedonorus arundinaceus*), brome (*Bromus* spp.), white clover (*Trifolium repens*) and red clover (*Trifolium pratense*). Ditching and tiling may be installed to improve drainage.

Dominant plant species

- tall fescue (*Schedonorus arundinaceus*), grass
- brome (*Bromus*), grass
- Kentucky bluegrass (*Poa pratensis*), grass
- white clover (*Trifolium repens*), other herbaceous
- red clover (*Trifolium pratense*), other herbaceous

Community 3.1

Pastureland/Forage community

These sites are managed for forage production and often include tall fescue (*Schedonorus arundinaceus*), brome (*Bromus* spp.), white clover (*Trifolium repens*) and red clover (*Trifolium pratense*). Selection of species will depend on the landowner's objectives.

Dominant plant species

- tall fescue (*Schedonorus arundinaceus*), grass
- brome (*Bromus*), grass
- Kentucky bluegrass (*Poa pratensis*), grass
- red clover (*Trifolium pratense*), other herbaceous
- white clover (*Trifolium repens*), other herbaceous

State 4

Cropland State

Hydrological modifications such as ditching and tiling are used on these sites to increase drainage and improve crop production. Common crops include corn (*Zea mays*), soybeans (*Glycine max*), and occasionally winter wheat (*Triticum aestivum*). Some landowners choose to convert sites to cool season grasses for a period before resuming cropland production. A return to the historical Reference State from State 4 is unlikely, if not impossible. Sites that have been transitioned to agriculture generally stay in production.

Dominant plant species

- corn (*Zea mays*), other herbaceous
- soybean (*Glycine*), other herbaceous

Community 4.1

Cropland community

This community is characterized by the management and production of row crop agriculture. Common species include corn, soybean and wheat. Many other crops are suitable for these sites, and species selection will depend upon the landowners goals and objectives. Hydrological modification are generally installed to improve drainage.

Dominant plant species

- soybean (*Glycine max*), other herbaceous
- corn (*Zea mays*), other herbaceous

Transition T1A

State 1 to 2

Severe disturbances, such as clearing or selective harvesting (oak/hickory removal) , will transition this site to State 2.

Transition T1C

State 1 to 3

Site is transitioned to an agricultural site focused on forage production. Management inputs would include clearing, site preparation, seeding and weed/brush control. Hydrological modifications may be installed to improve drainage.

Transition T1B

State 1 to 4

Site is transitioned to an agricultural site focused on row crop production. Management inputs would include clearing, site preparation, installation of hydrological modifications (ditching/tiling), planting, and weed control.

Restoration pathway R2A

State 2 to 1

Restoration would require long-term management inputs including planting of desired species, weed control, brush control, timber stand improvement, and restoration of natural hydrology.

Transition T2B

State 2 to 3

Site is cleared and forage/pasture production is initiated. Management inputs would include tree/shrub removal, site preparation, seeding, and weed/brush control.

Transition T2C

State 2 to 4

Site is cleared and row crop production is initiated. Hydrological modification such as ditching and tiling are installed. Other management inputs would include tree/shrub removal, site preparation, seeding, and weed control.

Transition T3B

State 3 to 2

Site is abandoned and slowly would transition to a wooded state dominated by deciduous trees. Species on site

would depend on the severity and length of disturbance and available seed sources.

Transition T3A State 3 to 4

Management inputs that transition a site from pasture or forage production to a site that is utilized for row crop production. Tiling and ditching is usually installed to improve drainage.

Transition T4A State 4 to 3

Management inputs to transition a site from cropland production to a state of pasture/forage production.

Additional community tables

Inventory data references

A Provisional Ecological Site Description (PESD) describes ecological potential and ecosystem dynamics of land areas and their potential management. Ecological sites are linked to soil survey map unit components, which allows for mapping of ecological sites. A PESD with a provisional status represents the lowest tier of documentation that is releasable to the public. No field level data have been collected as part of this PESD. It is expected that a PESD will continue to be refined through field verification and field sampling.

Reference and alternative state concepts, including the state-and-transition model and vegetative communities are not yet well-documented and will require field sampling for verification.

Other references

Brinson, M. M. 1993. A hydrogeomorphic classification for wetlands. Technical Report WRP-DE-4, U.S. Army Corps of Engineers, Engineer Waterways Experiment Station, Vicksburg, MS.

Braun, E. Lucy. 2001. Deciduous forests of eastern North America. Caldwell, N.J.: Blackburn Press.

Cleland, D. T., J. A. Freeouf, J. E. Keys, G. J. Nowacki, C. Carpenter, and W. H. McNab. 2007. Ecological Subregions: Sections and Subsections of the Coterminous United States. USDA Forest Service, General Technical Report WO-76. Washington, DC. 92 pp.

Comer P. J., Faber-Langendoen D, Evans R, Gawler S. C, Josse C, Kittel G, Menard S, Pyne M, Reid M, Schulz K, Snow K, and Teague J. 2003. Ecological Systems of the United States: A Working Classification of U.S. Terrestrial Systems. NatureServe, Arlington, Virginia.

Cowardin, L.M., V. Carter, F. C. Golet, and E.T. LaRoe. 1979. Classification of wetlands and deep water habitats of the United States. U.S. Dept. of Interior, Fish & Wildlife Service, Office of Biological Services, Washington DC. FWS/OBS-79/31. 142 pp.

Homoya, M. A., Abrell, D. B., Aldrich, J. R., & Post, T. W. (1985). The Natural Regions of Indiana. Indiana Academy of Science, 94, 245-269

Jackson, Marion T. 1997. The Natural heritage of Indiana. Bloomington: Indiana University Press, published in association with the Indiana Department of Natural Resources and the Indiana Academy of Science.

Landfire (Landfire National Vegetation Dynamics Database). 2009. Landfire National Vegetation Dynamics Models. Landfire Project, USDA Forest Service, U.S. Department of Interior. (<http://www.LANDFIRE.gov/index.php>: accessed 2020).

Mohlenbrock, R. H. and D. M. Ladd. 1978. Distribution of Illinois Vascular Plants. Southern Illinois Univ. Press, Carbondale and Edwardsville, Ill. 282 pp.

Mohlenbrock, R. H. 2003. Vascular Flora of Illinois, 3rd edition. Carbondale, Illinois: Southern Illinois University Press. 736 pp.

National Cooperative Soil Survey (NCSS). National Cooperative Soil Characterization Database. Available online: <https://ncsslabsdatamart.sc.egov.usda.gov/>. Accessed: 2020.

NatureServe. 2018. NatureServe Explorer: An online encyclopedia of life [web application]. Version 7.1. NatureServe, Arlington, Virginia. Available <http://explorer.natureserve.org>. (Association Detail Report: CEGL002427) (Accessed: 2020)

Soil Survey Staff, Natural Resources Conservation Service, United States Department of Agriculture. Web Soil Survey (SSS NRCS WSS). Available online at the following link: <https://websoilsurvey.sc.egov.usda.gov/>. Accessed 2020.

Soil Survey Staff, Natural Resources Conservation Service, United States Department of Agriculture. Official Soil Series Descriptions (SSS NRCS OSD). Available online. Accessed 2020. <https://soilseries.sc.egov.usda.gov/osdname.aspx>

United States Department of Agriculture, Natural Resources Conservation Service (USDA – NRCS). 2006. Land resource regions and major land resource areas of the United States, the Caribbean, and the Pacific Basin. USDA Handbook 296. 682 pp.

United States Department of Agriculture, Natural Resources Conservation Service. 2022. Land resource regions and major land resource areas of the United States, the Caribbean, and the Pacific Basin. U.S. Department of Agriculture, Agriculture Handbook 296.

USDA, NRCS. 2018. The PLANTS Database (<http://plants.usda.gov>, 1 March 2018). National Plant Data Team, Greensboro, NC 27401-4901 USA.

Voigt, J. W., and R. H. Mohlenbrock. 1964. Plant communities of southern Illinois. Southern Illinois University Press, Carbondale. 202 pp.

Whitaker, John O., Charles J. Amlaner, Marion T. Jackson, George R. Parker, and Peter Evans Scott. 2012. Habitats and ecological communities of Indiana presettlement to present. Bloomington: Indiana University Press.

Contributors

Anita Arends, Ecological Site Specialist, USDA-NRCS, Illinois
Ralph Tucker, Soil Survey Office Leader, USDA-NRCS, Missouri
Dena Anderson, Resource Soil Scientist, USDA-NRCS, Indiana
Zack Weber, Soil Scientist, USDA-NRCS, Illinois

Approval

Suzanne Mayne-Kinney, 12/30/2024

Rangeland health reference sheet

Interpreting Indicators of Rangeland Health is a qualitative assessment protocol used to determine ecosystem condition based on benchmark characteristics described in the Reference Sheet. A suite of 17 (or more) indicators are typically considered in an assessment. The ecological site(s) representative of an assessment location must be known prior to applying the protocol and must be verified based on soils and climate. Current plant community cannot be used to identify the ecological site.

Author(s)/participant(s)	
Contact for lead author	

Date	01/10/2025
Approved by	Suzanne Mayne-Kinney
Approval date	
Composition (Indicators 10 and 12) based on	Annual Production

Indicators

1. **Number and extent of rills:**

2. **Presence of water flow patterns:**

3. **Number and height of erosional pedestals or terracettes:**

4. **Bare ground from Ecological Site Description or other studies (rock, litter, lichen, moss, plant canopy are not bare ground):**

5. **Number of gullies and erosion associated with gullies:**

6. **Extent of wind scoured, blowouts and/or depositional areas:**

7. **Amount of litter movement (describe size and distance expected to travel):**

8. **Soil surface (top few mm) resistance to erosion (stability values are averages - most sites will show a range of values):**

9. **Soil surface structure and SOM content (include type of structure and A-horizon color and thickness):**

10. **Effect of community phase composition (relative proportion of different functional groups) and spatial distribution on infiltration and runoff:**

11. **Presence and thickness of compaction layer (usually none; describe soil profile features which may be mistaken for compaction on this site):**

12. **Functional/Structural Groups (list in order of descending dominance by above-ground annual-production or live foliar cover using symbols: >>, >, = to indicate much greater than, greater than, and equal to):**

Dominant:

Sub-dominant:

Other:

Additional:

13. **Amount of plant mortality and decadence (include which functional groups are expected to show mortality or decadence):**
-

14. **Average percent litter cover (%) and depth (in):**
-

15. **Expected annual annual-production (this is TOTAL above-ground annual-production, not just forage annual-production):**
-

16. **Potential invasive (including noxious) species (native and non-native). List species which BOTH characterize degraded states and have the potential to become a dominant or co-dominant species on the ecological site if their future establishment and growth is not actively controlled by management interventions. Species that become dominant for only one to several years (e.g., short-term response to drought or wildfire) are not invasive plants. Note that unlike other indicators, we are describing what is NOT expected in the reference state for the ecological site:**
-

17. **Perennial plant reproductive capability:**
-