

Ecological site F115XA012IL

Clayey Floodplain

Last updated: 12/30/2024

Accessed: 04/08/2026

General information

Provisional. A provisional ecological site description has undergone quality control and quality assurance review. It contains a working state and transition model and enough information to identify the ecological site.

MLRA notes

Major Land Resource Area (MLRA): 115X–Central Mississippi Valley Wooded Slopes

This MLRA is characterized by deeply dissected, loess-covered hills bordering well defined valleys of the Illinois, Mississippi, Missouri, Ohio, and Wabash Rivers and their tributaries. It is used to produce cash crops and livestock. About one-third of the area is forested, mostly on the steeper slopes. This area is in Illinois (50 percent), Missouri (36 percent), Indiana (13 percent), and Iowa (1 percent) in two separate areas. It makes up about 25,084 square miles (64,967 square kilometers).

Most of this area is in the Till Plains section and the Dissected Till Plains section of the Central Lowland province of the Interior Plains. The Springfield-Salem plateaus section of the Ozarks Plateaus province of the Interior Highlands occurs along the Missouri River and the Mississippi River south of the confluence with the Missouri River. The nearly level to very steep uplands are dissected by both large and small tributaries of the Illinois, Mississippi, Missouri, Ohio, and Wabash Rivers. The Ohio River flows along the southernmost boundary of this area in Indiana. Well defined valleys with broad flood plains and numerous stream terraces are along the major streams and rivers. The flood plains along the smaller streams are narrow. Broad summits are nearly level to undulating. Karst topography is common in some parts along the Missouri and Mississippi Rivers and their tributaries. Well-developed karst areas have hundreds of sinkholes, caves, springs, and losing streams. In the St. Louis area, many of the karst features have been obliterated by urban development.

Elevation ranges from 90 feet (20 meters) on the southernmost flood plains to 1,030 feet (320 meters) on the highest ridges. Local relief is mainly 10 to 50 feet (3 to 15 meters) but can be 50 to 150 feet (15 to 45 meters) in the steep, deeply dissected hills bordering rivers

and streams. The bluffs along the major rivers are generally 200 to 350 feet (60 to 105 meters) above the valley floor.

The uplands in this MLRA are covered almost entirely with Peoria Loess. The loess can be more than 7 feet (2 meters) thick on stable summits. On the steeper slopes, it is thin or does not occur. In Illinois, the loess is underlain mostly by Illinoian-age till that commonly contains a paleosol. Pre-Illinoian-age till is in parts of this MLRA in Iowa and Missouri and to a minor extent in the western part of Illinois. Wisconsin-age outwash, alluvial deposits, and sandy eolian material are on some of the stream terraces and on dunes along the major tributaries. The loess and glacial deposits are underlain by several bedrock systems. Pennsylvanian and Mississippian bedrock are the most extensive. To a lesser extent are Silurian, Devonian, Cretaceous, and Ordovician bedrock. Karst areas have formed where limestone is near the surface, mostly in the southern part of the MLRA along the Mississippi River and some of its major tributaries. Bedrock outcrops are common on the bluffs along the Mississippi, Ohio, and Wabash Rivers and their major tributaries and at the base of some steep slopes along minor streams and drainageways.

The annual precipitation ranges from 35 to 49 inches (880 to 1,250 millimeters) with a mean of 41 inches (1,050 millimeters). The annual temperature ranges from 48 to 58 degrees F (8.6 to 14.3 degrees C) with a mean of 54 degrees F (12.3 degrees C). The freeze-free period ranges from 150 to 220 days with a mean of 195 days.

Soils The dominant soil orders are Alfisols and, to a lesser extent, Entisols and Mollisols. The soils in the area have a mesic soil temperature regime, an aquic or udic soil moisture regime, and mixed or smectitic mineralogy. They are shallow to very deep, excessively drained to poorly drained, and loamy, silty, or clayey.

The soils on uplands in this area support natural hardwoods. Oak, hickory, and sugar maple are the dominant species. Big bluestem, little bluestem, and scattered oak and eastern redcedar grow on some sites. The soils on flood plains support mixed forest vegetation, mainly American elm, eastern cottonwood, river birch, green ash, silver maple, sweetgum, American sycamore, pin oak, pecan, and willow. Sedge and grass meadows and scattered trees are on some low-lying sites. (United States Department of Agriculture, Natural Resources Conservation Service, 2022)

LRU notes

Most of this LRU (Land Resource Unit) is in the glaciated Till Plains Section of the Central Lowland Province of the Interior Plains. The southeast corner is in the Highland Rim Section (locally known as the Shawnee Hills Section) of the Interior Low Plateaus Province of the Interior Plains. The nearly level to very steep uplands in this LRU are dissected by both large and small tributaries of the Wabash and Ohio Rivers. Well defined valleys with broad flood plains and numerous stream terraces are along the major streams and rivers. The flood plains along the smaller streams are narrow. Broad summits are nearly level to gently sloping.

This area is covered almost entirely with Wisconsin loess. The loess can be more than 7 feet (2 meters) thick on stable summits. On the steeper slopes, it is thin or does not occur. The loess throughout the area is underlain dominantly by glacial till. Wisconsin outwash, alluvial deposits, and sandy eolian material are on some of the stream terraces and on dunes along the major tributaries in the area. The loess and glacial drift are underlain by Pennsylvanian-age bedrock. Bedrock outcrops are common in the walls of the valleys along the Wabash and Ohio Rivers and at the base of some steep slopes along minor streams and drainageways.

The dominant soil orders in this LRU are Alfisols, Entisols, Inceptisols, and Mollisols. The soils in the area have a mesic soil temperature regime, a udic or aquic soil moisture regime, and dominantly mixed or smectitic mineralogy. The soils are very deep, poorly drained to excessively drained, and loamy, silty, or clayey. Nearly level Endoaqualfs (Iva series) and Argiaquolls (Ragsdale series) formed in loess on broad upland summits and flats. Nearly level to steep Hapludalfs (Alford, Iona, Muren, Stoy, and Sylvan series) and Fragiudalfs (Hosmer series) formed in loess on uplands. Hapludalfs (Alvin, Bloomfield, and Princeton series) and Argiudolls (Ade series) formed in sandy eolian material in areas of dunes on uplands and stream terraces. Steep and very steep Hapludalfs (Hickory series) formed in Illinoian till along the major streams and dissected upland drainageways. Hapludalfs (Wellston series) formed in siltstone or sandstone residuum on strongly sloping to steep side slopes underlain by bedrock.

The soils in the major stream valleys include Hapludolls (Carmi series), Argiudolls (Elston series), and Hapludalfs (Skelton series), all of which formed in outwash on nearly level to moderately sloping stream terraces and outwash plains. Endoaquolls (Montgomery series), Endoaquepts (Zipp series), Epiaqualfs (McGary series), and Hapludalfs (Shircliff and Markland series) formed in clayey lacustrine sediments on nearly level to strongly sloping lacustrine terraces or lake plains. Endoaquepts (Evansville series), Endoaquolls (Patton series), and Hapludalfs (Henshaw and Uniontown series) formed in silty sediments on terraces and lake plains.

LRU notes (excerpts from Land resource regions and major land resource areas of the United States, the Caribbean, and the Pacific Basin. USDA Handbook 296, 2006)

Classification relationships

Major Land Resource Area (MLRA) 115X—Central Mississippi Valley Wooded Slopes

U.S. Forest Service Ecoregions (Cleland et al. 2007):

Domain: Humid Temperate Domain

Division: Hot Continental Division

Province: Eastern Broadleaf Forest (Continental)

Province Code: 222

Section Code: 222G, 222D

Classification System: International Vegetation Classification - Natural

Classification Level: Association

International Vegetation Classification Hierarchy

Class: 1. Forest & Woodland

Subclass: 1.B. Temperate & Boreal Forest & Woodland

Formation: 1.B.3. Temperate Flooded & Swamp Forest

Division: 1.B.3.Na. Eastern North American-Great Plains Flooded & Swamp Forest

Macrogroup: M029. Central Hardwood Floodplain Forest

Ecological site concept

This deciduous floodplain forest community is found on clayey soils in LRU 115XA. Sites are located on floodplains and low floodplain steps. Soils are moderately well drained and formed in clayey alluvium. The reference community is a mature deciduous floodplain forest with a closed, mixed canopy. Flooding frequency for these sites is occasional to frequent. Canopy species include green ash (*Fraxinus pensylvanica*), hackberry (*Celtis occidentalis*), American elm (*Ulmus americana*), silver maple (*Acer saccharinum*), and occasionally, pecan (*Carya illinoensis*).

The shrub layer often contains hawthorn (*Crataegus* spp.) and possumhaw (*Ilex decidua*). Understory plants include wood nettle (*Laportea canadensis*), stinging nettle (*Urtica dioica*), bluejoint grass (*Calamagrostis canadensis*), Virginia wild rye (*Elymus virginicus*), false nettle (*Boehmeria cylindrica*), Gray's sedge (*Carex grayi*), clearweed (*Pilea pumila*), violets (*Viola* spp.), touch-me-not (*Impatiens* spp.). Community composition will vary depending on flooding regime.

Recent severely flooded sites may exhibit cottonwood (*Populus deltoides*) and/or willow (*Salix* spp.) after disturbance.

Associated sites

F115XA014IL	Wet Silty Floodplain Wet Silty Floodplain. These sites are composed of silty textured soils and are somewhat poorly drained.
F115XA015IL	Loamy Floodplain Loamy Floodplain. These sites are on loamy soils that are moderately well drained to well drained.

Similar sites

F115XA014IL	Wet Silty Floodplain Wet Silty Floodplain. These sites are composed of silty textured soils and are somewhat poorly drained.
-------------	--

Table 1. Dominant plant species

Tree	(1) <i>Acer saccharinum</i> (2) <i>Fraxinus pennsylvanica</i>
Shrub	(1) <i>Ilex decidua</i> (2) <i>Crataegus</i>
Herbaceous	Not specified

Physiographic features

These sites are located on floodplains and floodplain steps. Elevation of these sites are generally between 341' to 499'. Parent material kind and origin is clayey alluvium. Slopes range from 0-2%. Runoff is very low, and the wet layer depths are 25-40 inches.

Table 2. Representative physiographic features

Landforms	(1) Valley > Flood plain (2) Valley > Flood-plain step
Runoff class	Very low
Flooding frequency	Occasional to frequent
Ponding frequency	None
Elevation	104–152 m
Slope	0–2%
Water table depth	64–102 cm
Aspect	Aspect is not a significant factor

Climatic features

About 60 percent of the precipitation falls during the freeze-free period. Most of the rainfall occurs as high-intensity, convective thunderstorms in summer. Snowfall is common in winter. The following information is based on data taken from weather stations within MLRA 115X as calculated in EDIT.

Table 3. Representative climatic features

Frost-free period (characteristic range)	165-179 days
Freeze-free period (characteristic range)	187-206 days
Precipitation total (characteristic range)	1,168-1,194 mm
Frost-free period (actual range)	164-180 days
Freeze-free period (actual range)	186-206 days

Precipitation total (actual range)	1,143-1,194 mm
Frost-free period (average)	172 days
Freeze-free period (average)	197 days
Precipitation total (average)	1,168 mm

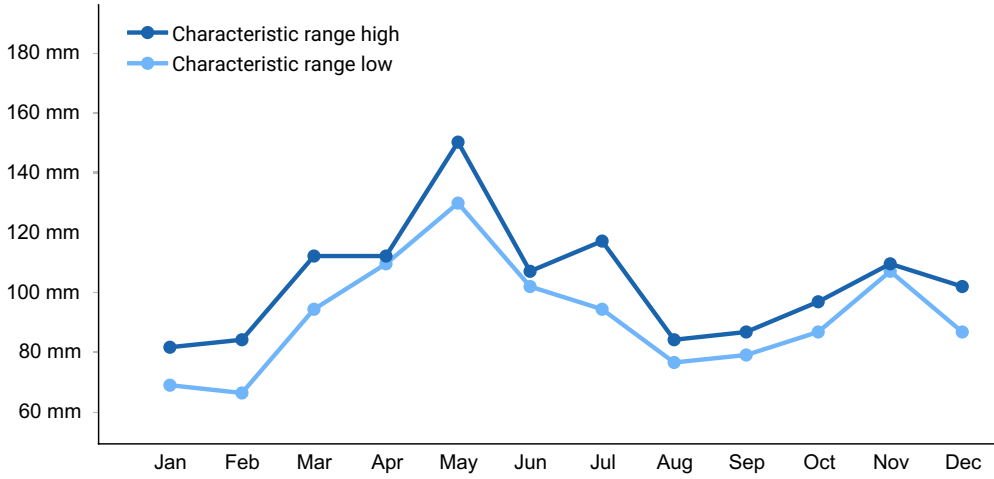

Figure 1. Monthly precipitation range

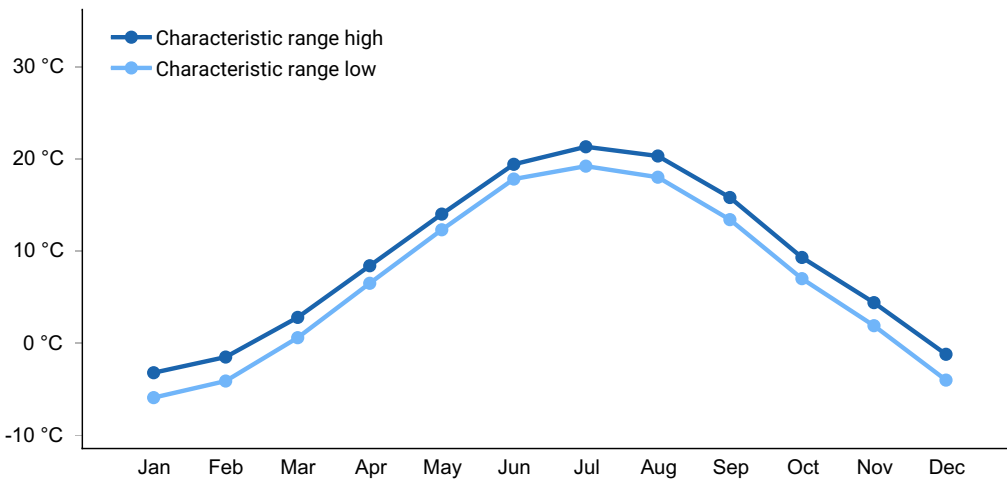

Figure 2. Monthly minimum temperature range

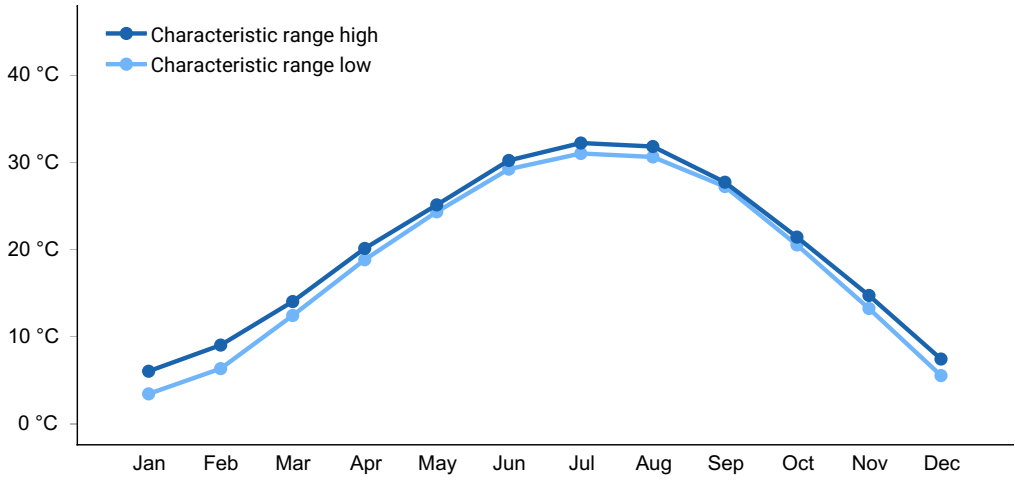

Figure 3. Monthly maximum temperature range

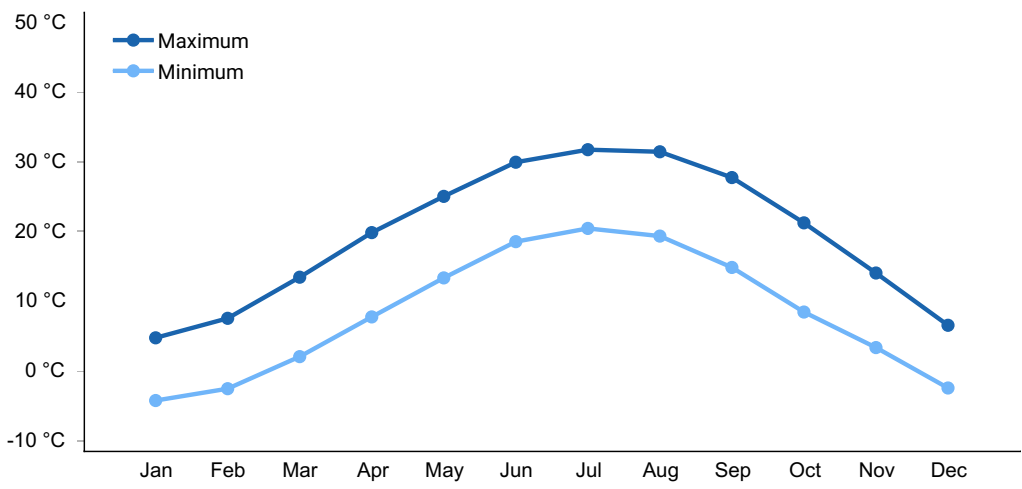

Figure 4. Monthly average minimum and maximum temperature

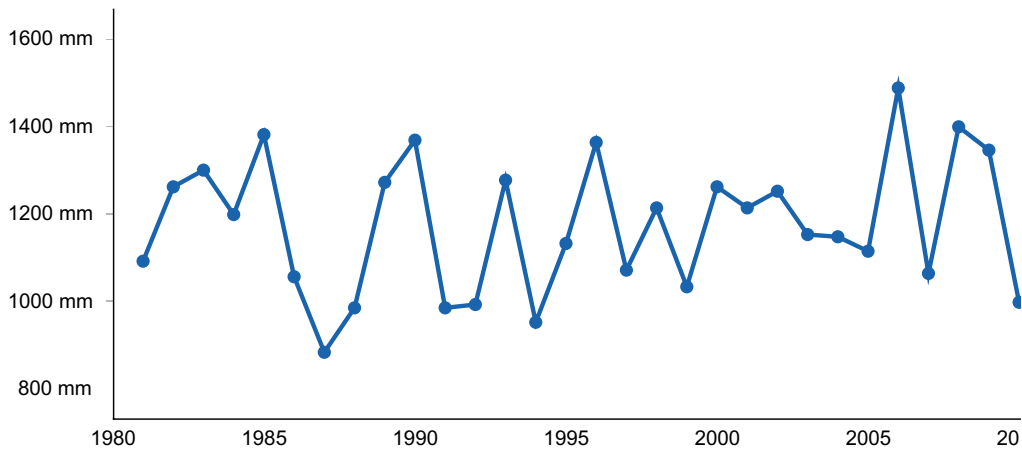

Figure 5. Annual precipitation pattern

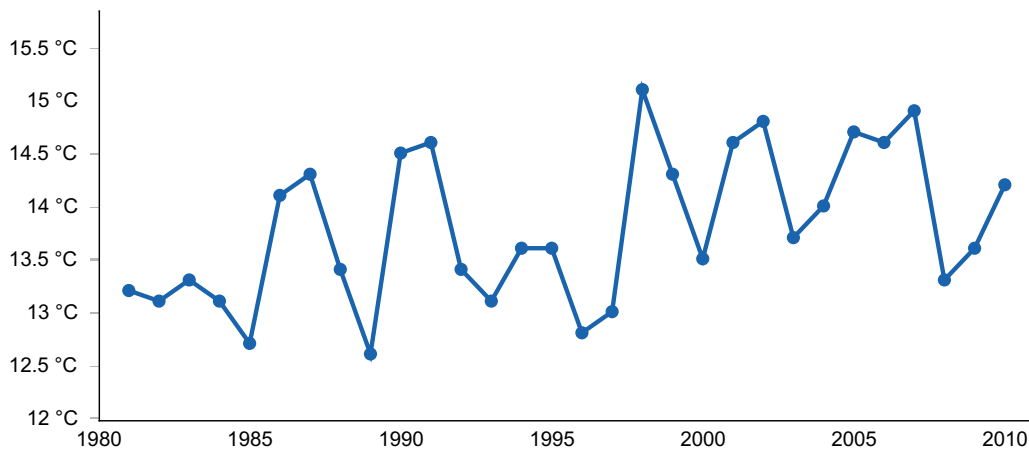

Figure 6. Annual average temperature pattern

Climate stations used

- (1) HUTSONVILLE PWR PLT [USC00114317], Fairbanks, IL
- (2) VINCENNES 5 NE [USC00129113], Vincennes, IN
- (3) MT CARMEL [USC00115888], Mount Carmel, IL
- (4) MT VERNON [USC00126001], Uniontown, IN
- (5) EVANSVILLE MUSEUM [USC00122731], Henderson, IN
- (6) J T MYERS LOCKS & DAM [USC00128967], Morganfield, IN

Influencing water features

Clayey Floodplain sites are influenced by riparian water features. Flooding is occasional to frequent, but there is no ponding. The seasonal wet layer for these soils is generally 25 to 40 inches.

Soil features

Soil series associated with this site include Woodmere which are formed in 20 to 36 inches of recent alluvium and the underlying older alluvial materials. Sites are very deep, moderately well drained, and have slow permeability. These soils have a sodium adsorption ratio of zero; a pH of 4.5 to 7.3; and an available water capacity (AWC) of 7-8 inches.

Table 4. Representative soil features

Parent material	(1) Alluvium
Surface texture	(1) Silt loam (2) Silty clay loam
Drainage class	Moderately well drained
Permeability class	Slow

Soil depth	152–203 cm
Surface fragment cover <=3"	0%
Surface fragment cover >3"	0%
Available water capacity (Depth not specified)	17.78–20.32 cm
Calcium carbonate equivalent (Depth not specified)	0%
Electrical conductivity (Depth not specified)	0 mmhos/cm
Soil reaction (1:1 water) (Depth not specified)	4.5–7.3
Subsurface fragment volume <=3" (Depth not specified)	0%
Subsurface fragment volume >3" (Depth not specified)	0%

Ecological dynamics

These ecological sites occur on floodplains along the Ohio River in the southern portion of LRU 115XA. The reference community is a deciduous floodplain forest. Sites in this PES group are deep, moderately well drained, have no ponding, and are flooded occasionally to frequently. Flooding frequency, depth, and length will influence the vegetative communities on these sites.

Many rivers and streams today reflect long-term, substantial alterations to the once natural dynamics that controlled these riparian systems. Dams, levees, tiling, ditching, development, agricultural water use/runoff and urban water use/runoff have often modified the once natural flooding regime of these sites. Most Clayey Floodplain sites have incurred some degree of disturbance – either through hydrological modifications – or through clearing, logging, selective harvest, grazing, or development.

The majority of these sites have been converted to agriculture – either cropland or hayland production. Bank erosion and negative water quality impacts are common when intensive cropping is conducted without watershed buffers. Invasive non-native vegetation is another serious concern in many remaining wooded areas

State and transition model

Ecosystem states

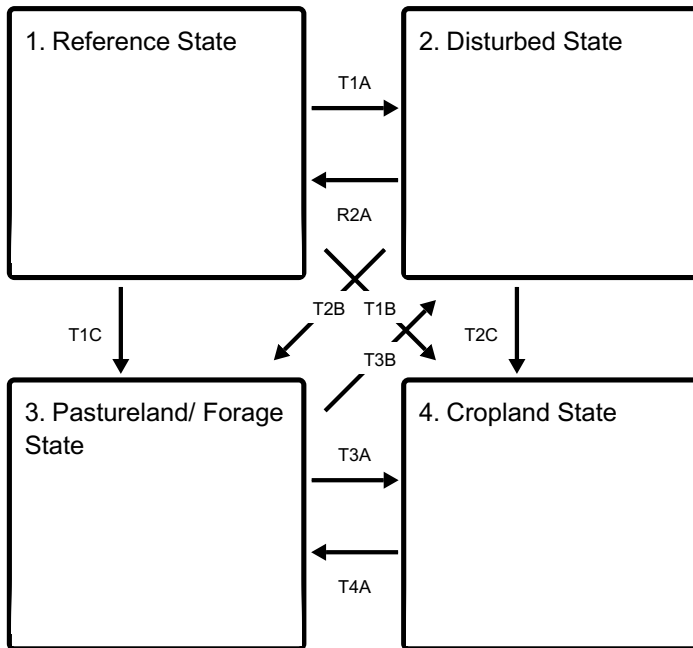

T1A - Large scale disturbance

T1C - Clearing of site; agricultural production - forage

T1B - Clearing of site; agricultural production - row crops.

R2A - Restoration inputs such as planting, brush control, prescribed fire, and timber stand improvement.

T2B - Clearing; agricultural production - forage

T2C - Clearing; agricultural production - row crops

T3B - Abandonment of agricultural practices

T3A - Site preparation and tillage, seeding, weed control, cropland management

T4A - Transition site to forage production; seeding; weed/brush control; pasture management

State 1 submodel, plant communities

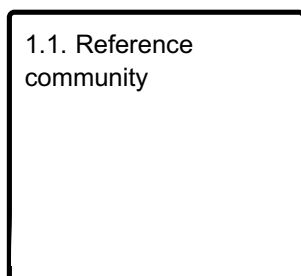

State 2 submodel, plant communities

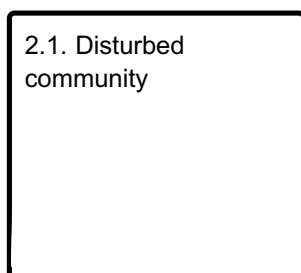

State 3 submodel, plant communities

3.1.
Pastureland/Forage
community

State 4 submodel, plant communities

4.1. Cropland
community

State 1 Reference State

The historic reference state for this ecological site was an old-growth riverine deciduous forest with maximum trees ages from 100-300 years old. Sites were disturbed periodically via flooding but the overall, these communities were stable and long-lived. Numerous tree species were co-dominant on these mature forested sites and the natural herbaceous layer was robust and diverse. Canopy species included green ash (*Fraxinus pennsylvanica*), silver maple (*Acer saccharinum*), hackberry (*Celtis occidentalis*), and American elm (*Ulmus americana*). Possumhaw (*Ilex decidua*) and hawthorn (*Crataegus* spp.) were common shrubs. Willow (*Salix* spp.) and cottonwood (*Populus deltoides*) will increase on recently disturbed sites.

Dominant plant species

- green ash (*Fraxinus pennsylvanica*), tree
- hackberry (*Celtis*), tree
- elm (*Ulmus*), tree
- silver maple (*Acer saccharinum*), tree
- possumhaw (*Ilex decidua*), shrub
- hawthorn (*Crataegus*), shrub
- sedge (*Carex*), grass
- Canadian woodnettle (*Laportea canadensis*), other herbaceous
- stinging nettle (*Urtica dioica*), other herbaceous

Community 1.1 Reference community

This deciduous floodplain forest community is found on clayey soils in MRLA 115A. The

reference community is a mature deciduous floodplain forest with a closed, mixed canopy. Flooding frequency for these sites is occasional to frequent. Canopy species include green ash (*Fraxinus pennsylvanica*), hackberry (*Celtis occidentalis*), American elm (*Ulmus americana*), silver maple (*Acer saccharinum*), and occasionally, pecan (*Carya illinoensis*). The shrub layer often contains hawthorn (*Crataegus* spp.) and possumhaw (*Ilex decidua*). Understory plants include wood nettle (*Laportea canadensis*), stinging nettle (*Urtica dioica*), bluejoint grass (*Calamagrostis canadensis*), Virginia wild rye (*Elymus virginicus*), false nettle (*Boehmeria cylindrica*), Gray's sedge (*Carex grayi*), clearweed (*Pilea pumila*), violets (*Viola* spp.), touch-me-not (*Impatiens* spp.). Community composition will vary depending on flooding regime. Recent severely flooded sites may exhibit cottonwood (*Populus deltoides*) and/or willow (*Salix* spp.) dominance post disturbance.

Dominant plant species

- green ash (*Fraxinus pennsylvanica*), tree
- hackberry (*Celtis*), tree
- silver maple (*Acer saccharinum*), tree
- elm (*Ulmus*), tree
- possumhaw (*Ilex decidua*), shrub
- hawthorn (*Crataegus*), shrub
- sedge (*Carex*), grass
- stinging nettle (*Urtica dioica*), other herbaceous
- Canadian woodnettle (*Laportea canadensis*), other herbaceous

State 2

Disturbed State

Most remaining Clayey Floodplain sites have been altered due to disturbances including hydrological modification, clearing, logging, grazing, and development. Remaining wooded sites may be in various stages of succession with a variety of trees depending on seed sources and severity of disturbance. Introduction of non-native plant species to these sites is not uncommon, and without management control, these invasive plants will fundamentally alter the plant community. These disturbed sites are often transitioned to Pastureland (State 3) or cropland (State 4).

Dominant plant species

- maple (*Acer*), tree
- hackberry (*Celtis*), tree
- ash (*Fraxinus*), tree
- willow (*Salix*), shrub
- cottonwood (*Populus*), shrub
- sedge (*Carex*), grass
- nettle (*Urtica*), other herbaceous
- Canadian woodnettle (*Laportea canadensis*), other herbaceous

Community 2.1

Disturbed community

Many Clayey Floodplain areas have incurred some degree of disturbance – either through hydrological modifications – or through clearing, logging, selective harvest, grazing, or development. Numerous species may be on disturbed sites depending on seed sources and the type/length of disturbances. Maple, ash, hackberry, poplar, and cottonwood are common.

Dominant plant species

- red maple (*Acer rubrum*), tree
- silver maple (*Acer saccharinum*), tree
- green ash (*Fraxinus pennsylvanica*), tree
- possumhaw (*Ilex decidua*), shrub
- dogwood (*Cornus*), shrub
- willow (*Salix*), shrub
- laportea (*Laportea*), other herbaceous

State 3

Pastureland/ Forage State

A portion of these sites have been converted to pastureland or forage production. Species selection will depend upon the objectives and goals of the landowner; however, commonly planted grasses include tall fescue (*Schedonorus arundinaceus*), brome (*Bromus* spp.), white clover (*Trifolium repens*) and red clover (*Trifolium pratense*). Species health and productivity are determined by the management and long-term overgrazing on some sites has caused soil erosion and compaction.

Dominant plant species

- tall fescue (*Schedonorus arundinaceus*), grass
- brome (*Bromus*), grass
- Kentucky bluegrass (*Poa pratensis*), grass
- white clover (*Trifolium repens*), other herbaceous
- red clover (*Trifolium pratense*), other herbaceous

Community 3.1

Pastureland/Forage community

These sites are managed for forage production and often include tall fescue (*Schedonorus arundinaceus*), brome (*Bromus* spp.), white clover (*Trifolium repens*) and red clover (*Trifolium pratense*). Selection of species will depend on the landowner's objectives.

Dominant plant species

- tall fescue (*Schedonorus arundinaceus*), grass
- brome (*Bromus*), grass
- Kentucky bluegrass (*Poa pratensis*), grass
- red clover (*Trifolium pratense*), other herbaceous
- white clover (*Trifolium repens*), other herbaceous

State 4

Cropland State

Hydrological modifications such as ditching and tiling are often used on these sites to increase crop production. Common crops include corn (*Zea mays*), soybeans (*Glycine max*), and occasionally winter wheat (*Triticum aestivum*). Some landowners choose to convert sites to cool season grasses for a period before resuming cropland production. A return to the historical Reference State from State 4 is unlikely, if not impossible.

Dominant plant species

- corn (*Zea mays*), other herbaceous
- soybean (*Glycine*), other herbaceous

Community 4.1

Cropland community

This community is characterized by the management and production of row crop agriculture. Common species include corn, soybean and wheat. Many other crops are suitable for these sites, and species selection will depend upon the landowners goals and objectives.

Dominant plant species

- soybean (*Glycine max*), other herbaceous
- corn (*Zea mays*), other herbaceous

Transition T1A

State 1 to 2

Severe disturbances, such as clearing or selective harvesting (oak/hickory removal) , will transition this site to State 2.

Transition T1C

State 1 to 3

Site is transitioned to an agricultural site focused on forage production. Management inputs would include clearing, site preparation, seeding and weed/brush control.

Transition T1B

State 1 to 4

Site is transitioned to an agricultural site focused on row crop production. Management inputs would include clearing, site preparation, seeding and weed control. Hydrological modifications are often installed to aid in drainage.

Restoration pathway R2A

State 2 to 1

Restoration would require long-term management inputs including planting of desired species, weed control, brush control, timber stand improvement, and prescribed fire.

Transition T2B

State 2 to 3

Site is cleared and forage/pasture production is initiated. Management inputs would include tree/shrub removal, site preparation, seeding, and weed/brush control.

Transition T2C

State 2 to 4

Site is cleared and row crop production is initiated. Management inputs would include tree/shrub removal, site preparation, tillage, seeding, and weed control.

Transition T3B

State 3 to 2

Site is abandoned and slowly would transition to a wooded state dominated by deciduous trees. Species on site would depend on the severity and length of disturbance and available seed sources.

Transition T3A

State 3 to 4

Management inputs that transition a site from pasture or forage production to a site that is utilized for row crop production.

Transition T4A

State 4 to 3

Management inputs to transition a site from cropland production to a state of pasture/forage production.

Additional community tables

Inventory data references

A Provisional Ecological Site Description (PESD) describes ecological potential and ecosystem dynamics of land areas and their potential management. Ecological sites are linked to soil survey map unit components, which allows for mapping of ecological sites. A PESD with a provisional status represents the lowest tier of documentation that is releasable to the public. No field level data have been collected as part of this PESD. It is expected that a PESD will continue to be refined through field verification and field sampling.

Reference and alternative state concepts, including the state-and-transition model and vegetative communities are not yet well-documented and will require field sampling for verification.

Other references

Brinson, M. M. 1993. A hydrogeomorphic classification for wetlands. Technical Report WRP-DE-4, U.S. Army Corps of Engineers, Engineer Waterways Experiment Station, Vicksburg, MS.

Braun, E. Lucy. 2001. Deciduous forests of eastern North America. Caldwell, N.J.: Blackburn Press.

Cleland, D. T., J. A. Freeouf, J. E. Keys, G. J. Nowacki, C. Carpenter, and W. H. McNab. 2007. Ecological Subregions: Sections and Subsections of the Conterminous United States. USDA Forest Service, General Technical Report WO-76. Washington, DC. 92 pp.

Comer P. J., Faber-Langendoen D, Evans R, Gawler S. C, Josse C, Kittel G, Menard S, Pyne M, Reid M, Schulz K, Snow K, and Teague J. 2003. Ecological Systems of the United States: A Working Classification of U.S. Terrestrial Systems. NatureServe, Arlington, Virginia.

Cowardin, L.M., V. Carter, F. C. Golet, and E.T. LaRoe. 1979. Classification of wetlands and deep water habitats of the United States. U.S. Dept. of Interior, Fish & Wildlife Service, Office of Biological Services, Washington DC. FWS/OBS-79/31. 142 pp.

Homoya, M. A., Abrell, D. B., Aldrich, J. R., & Post, T. W. (1985). The Natural Regions of Indiana. Indiana Academy of Science, 94, 245-269

Jackson, Marion T. 1997. The Natural heritage of Indiana. Bloomington: Indiana University Press, published in association with the Indiana Department of Natural Resources and the Indiana Academy of Science.

- Landfire (Landfire National Vegetation Dynamics Database). 2009. Landfire National Vegetation Dynamics Models. Landfire Project, USDA Forest Service, U.S. Department of Interior. (<http://www.LANDFIRE.gov/index.php>: accessed 2020).
- Mohlenbrock, R. H. and D. M. Ladd. 1978. Distribution of Illinois Vascular Plants. Southern Illinois Univ. Press, Carbondale and Edwardsville, Ill. 282 pp.
- Mohlenbrock, R. H. 2003. Vascular Flora of Illinois, 3rd edition. Carbondale, Illinois: Southern Illinois University Press. 736 pp.
- National Cooperative Soil Survey (NCSS). National Cooperative Soil Characterization Database. Available online: <https://ncsslabsdatamart.sc.egov.usda.gov/>. Accessed: 2020.
- NatureServe. 2018. NatureServe Explorer: An online encyclopedia of life [web application]. Version 7.1. NatureServe, Arlington, Virginia. Available <http://explorer.natureserve.org>. (Association Detail Report: CEGL002427) (Accessed: 2020)
- Soil Survey Staff, Natural Resources Conservation Service, United States Department of Agriculture. Web Soil Survey (SSS NRCS WSS). Available online at the following link: <https://websoilsurvey.sc.egov.usda.gov/>. Accessed 2020.
- Soil Survey Staff, Natural Resources Conservation Service, United States Department of Agriculture. Official Soil Series Descriptions (SSS NRCS OSD). Available online. Accessed 2020. <https://soilseries.sc.egov.usda.gov/osdname.aspx>
- United States Department of Agriculture, Natural Resources Conservation Service (USDA – NRCS). 2006. Land resource regions and major land resource areas of the United States, the Caribbean, and the Pacific Basin. USDA Handbook 296. 682 pp.
- United States Department of Agriculture, Natural Resources Conservation Service. 2022. Land resource regions and major land resource areas of the United States, the Caribbean, and the Pacific Basin. U.S. Department of Agriculture, Agriculture Handbook 296.
- USDA, NRCS. 2018. The PLANTS Database (<http://plants.usda.gov>, 1 March 2018). National Plant Data Team, Greensboro, NC 27401-4901 USA.
- Voigt, J. W., and R. H. Mohlenbrock. 1964. Plant communities of southern Illinois. Southern Illinois University Press, Carbondale. 202 pp.
- Whitaker, John O., Charles J. Amlaner, Marion T. Jackson, George R. Parker, and Peter Evans Scott. 2012. Habitats and ecological communities of Indiana presettlement to present. Bloomington: Indiana University Press.

Contributors

Anita Arends, Ecological Site Specialist, USDA-NRCS, Illinois
Ralph Tucker, Soil Survey Office Leader, USDA-NRCS, Missouri
Dena Anderson, Resource Soil Scientist, USDA-NRCS, Indiana
Zack Weber, Soil Scientist, USDA-NRCS, Illinois

Rangeland health reference sheet

Interpreting Indicators of Rangeland Health is a qualitative assessment protocol used to determine ecosystem condition based on benchmark characteristics described in the Reference Sheet. A suite of 17 (or more) indicators are typically considered in an assessment. The ecological site(s) representative of an assessment location must be known prior to applying the protocol and must be verified based on soils and climate. Current plant community cannot be used to identify the ecological site.

Author(s)/participant(s)	
Contact for lead author	
Date	04/08/2026
Approved by	Suzanne Mayne-Kinney
Approval date	
Composition (Indicators 10 and 12) based on	Annual Production

Indicators

1. Number and extent of rills:

2. Presence of water flow patterns:

3. Number and height of erosional pedestals or terracettes:

4. Bare ground from Ecological Site Description or other studies (rock, litter, lichen, moss, plant canopy are not bare ground):

5. **Number of gullies and erosion associated with gullies:**

6. **Extent of wind scoured, blowouts and/or depositional areas:**

7. **Amount of litter movement (describe size and distance expected to travel):**

8. **Soil surface (top few mm) resistance to erosion (stability values are averages - most sites will show a range of values):**

9. **Soil surface structure and SOM content (include type of structure and A-horizon color and thickness):**

10. **Effect of community phase composition (relative proportion of different functional groups) and spatial distribution on infiltration and runoff:**

11. **Presence and thickness of compaction layer (usually none; describe soil profile features which may be mistaken for compaction on this site):**

12. **Functional/Structural Groups (list in order of descending dominance by above-ground annual-production or live foliar cover using symbols: >>, >, = to indicate much greater than, greater than, and equal to):**

Dominant:

Sub-dominant:

Other:

Additional:

13. **Amount of plant mortality and decadence (include which functional groups are**

expected to show mortality or decadence):

14. **Average percent litter cover (%) and depth (in):**

15. **Expected annual annual-production (this is TOTAL above-ground annual-production, not just forage annual-production):**

16. **Potential invasive (including noxious) species (native and non-native). List species which BOTH characterize degraded states and have the potential to become a dominant or co-dominant species on the ecological site if their future establishment and growth is not actively controlled by management interventions. Species that become dominant for only one to several years (e.g., short-term response to drought or wildfire) are not invasive plants. Note that unlike other indicators, we are describing what is NOT expected in the reference state for the ecological site:**

17. **Perennial plant reproductive capability:**
