

Ecological site F127XY016WV Rubby Upland Conifer Forest

Last updated: 6/06/2022
Accessed: 06/04/2023

General information

Provisional. A provisional ecological site description has undergone quality control and quality assurance review. It contains a working state and transition model and enough information to identify the ecological site.

MLRA notes

Major Land Resource Area (MLRA): 127X—Eastern Allegheny Plateau and Mountains

This ecosite is found in mountains, plateau in MLRA 127: Eastern Allegheny Plateau and Mountains. This site occupies the Allegheny Mountain Section of the Appalachian Highlands of the Appalachian Plateau Province. The deeply dissected plateau in this area terminates in a high escarpment, the Allegheny Front, in the eastern part of the area. Steep slopes are dominant, but level to gently rolling plateau remnants are conspicuous in the northern part of the area. The area is dominantly forest, containing large blocks of state forest, game lands, and national forest. Less than one-tenth of the MLRA consists of urban areas

Classification relationships

USDA-NRCS (USDA2 2006):

Land Resource Region (LRR): N—East and Central Farming and Forest Region

Major Land Resource Area (MLRA): 127—Eastern Allegheny Plateau and Mountains

USDA-FS (Cleland et al. 2007)

Province: 211 – Northeastern Mixed Forest Province (in Part)

Section: 211G - Northern Unglaciaded Allegheny Plateau

Subsection: 211Ga – Allegheny High Plateau

211Gb – Allegheny Deep Valleys

Province: 221 - Eastern Broadleaf Province (in part)

Section: 221E - Southern Unglaciaded Allegheny Plateau (in part)

Subsection: 221Ea - Pittsburgh Low Plateau

Province: M221 – Central Appalachian Broadleaf Forest – Coniferous Forest - Meadow Province (in part)

Section: M221B - Allegheny Mountains

Subsection: M221Ba – Northern High Allegheny Mountains

M221Bb – Western Allegheny Mountains

M221Bc – Southern High Allegheny Mountains

M221Bd – Eastern Allegheny Mountain and Valley

M221Be – Western Allegheny Mountain and Valley

M221Bf – Allegheny Mountain Plateau

Section: M221C - Northern Cumberland Mountains

Subsection: M221Ca – Western Coal Fields

This site crosswalks to Landfire biophysical setting (BpS) Central and Southern Appalachian Spruce-Fir Forest system (Landfire BPS 1350 and NatureServe ecological system CES202.028). Component associations include:

- *Picea rubens* / *Betula alleghaniensis* / *Bazzania trilobata* Forest (CEGL008501, G2)

- *Picea rubens* - (*Abies fraseri*) / *Vaccinium erythrocarpum* / *Oxalis montana* - *Dryopteris campyloptera* /

Hylocomium splendens Forest (CEGL007131, G2)

- *Picea rubens* / *Kalmia latifolia* - *Menziesia pilosa* (CEGL006254, G2)

- *Picea rubens* - (*Tsuga canadensis*) / *Rhododendron maximum* Forest (CEGL006152, G2G3)

(Source: Landfire 2009)

Ecological site concept

The Rubbly Upland Conifer Forest ecological site occurs on high elevation Spodosols, with rubbly or very rubbly surface rock fragments and is situated on sandstone dominated geologies of the Pottsville formation interbedded with acid shale and siltstone. This site coincides with the Central and Southern Appalachian Spruce-Fir Forest system (NatureServe 2009), but lacks the fir presence in native ecological communities. This system consists of uneven-aged forests generally dominated by red spruce (*Picea rubens*), accompanied by a mixture of hardwood species. Red spruce and yellow birch are key species of this site, dominating the reference state condition, with red spruce occurring at 30% or more in the overstory composition. Ground cover and surface rock fragment cover is strongly dominated by three-lobed bazzania, sometimes forming bazzania carpets on the forest floor. The forest floor is composed of surface organic matter accumulations as O horizons varying in thickness, often classifying as folistic epipedons. Elevation and orographic effects make the climate cool and moist, with heavy moisture input from fog as well as high rainfall. A frigid soil temperature regime and a perudic soil moisture regime characterize the site. Strong winds, extreme cold, rime ice, and other extreme weather are periodically important and affect communities on exposed mountain faces. Historic logging and burning practices of the 19th and 20th centuries significantly impacted this ecological site. The reference state or near references state conditions provide important habitat opportunities for the Cheat Mountain salamander (*Plethedon nettingi*) and Northern flying squirrel (*Glaucomys sabrinus*).

Associated sites

F127XY002WV	Spodic Intergrade Shale Upland Hardwood And Conifer Forest Spodic Intergrade Shale Upland Hardwood and Conifer Forest - similar ecological communities, climactic influences, disturbance influences, and landscapes. The biggest difference is between the acid shale Chemung and Hampshire geologies of the Spodic Intergrade Shale Upland Hardwood and Conifer Forest and the Pottsville acid sandstone geologies of the Rubbly Upland Conifer Forest.
F127XY001WV	Spodic Shale Upland Conifer Forest Spodic Shale Upland Conifer Forest - similar ecological communities, climactic influences, disturbance influences, and landscapes. The biggest difference is between acid shale Chemung and Hampshire geologies of the Spodic Shale Upland Conifer Forest and the Pottsville acid sandstone geologies of the Rubbly Upland Conifer Forest.

Similar sites

F127XY001WV	Spodic Shale Upland Conifer Forest Spodic Shale Upland Conifer Forest
F127XY002WV	Spodic Intergrade Shale Upland Hardwood And Conifer Forest Spodic Intergrade Shale Upland Hardwood and Conifer Forest

Table 1. Dominant plant species

Tree	(1) <i>Picea rubens</i> (2) <i>Betula alleghaniensis</i>
Shrub	Not specified
Herbaceous	(1) <i>Bazzania trilobata</i>

Physiographic features

This ecological site occupies mountain terrain with steep slopes ranging between 3-80% in slope gradient. Ridges, summits, and backslopes make up the majority of this ecological site. Steep slopes are dominant but level to gently rolling plateau remnants are present too.

Table 2. Representative physiographic features

Landforms	(1) Mountains > Mountain slope (2) Mountains > Ridge
Runoff class	Very low to medium
Elevation	1,295–3,985 ft
Slope	3–80%
Water table depth	72 in
Aspect	W, NW, N, NE, E, SE, S, SW

Climatic features

The climate is characteristic of other ecological sites in high elevation areas of the Eastern Allegheny Plateau and Mountains with a warm, humid summer climate with cold winters and moderate snowfall. Rainfall occurs mostly as high intensity convective thunderstorms. A perudic moisture regime and frigid soil temperature regime characterize the site. On many days in a normal winter there is no snow cover, but some years the ground is snow covered all winter. Cloudiness is more common than clear skies. Rainfall is heaviest in summer and lowest in the fall. During the growing season, rainfall often exceeds potential evapo-transpiration. Long dry periods seldom occur.

Table 3. Representative climatic features

Frost-free period (characteristic range)	68-92 days
Freeze-free period (characteristic range)	102-123 days
Precipitation total (characteristic range)	52-54 in
Frost-free period (actual range)	62-98 days
Freeze-free period (actual range)	97-128 days
Precipitation total (actual range)	52-54 in
Frost-free period (average)	80 days
Freeze-free period (average)	113 days
Precipitation total (average)	53 in

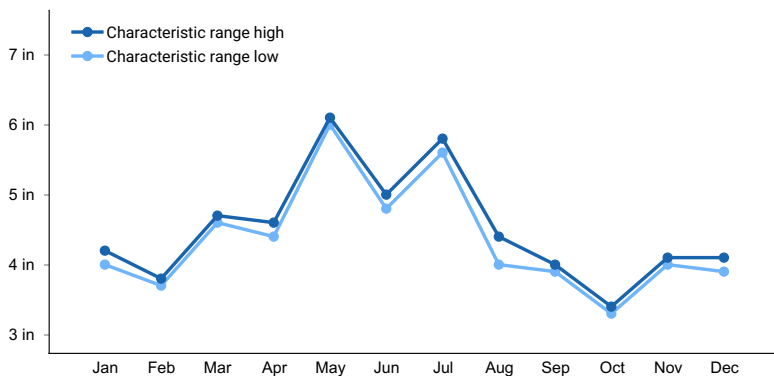

Figure 1. Monthly precipitation range

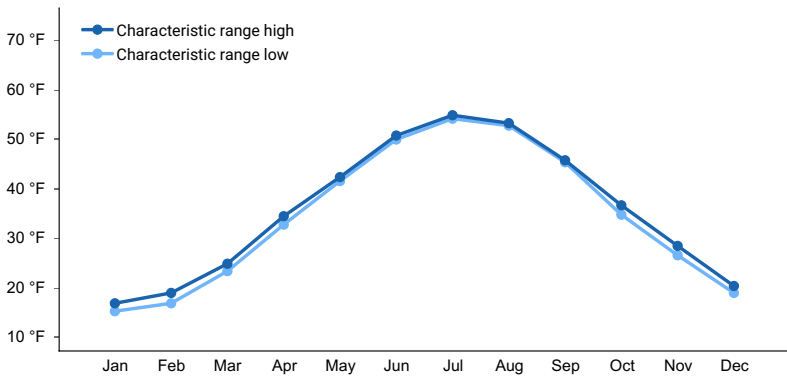

Figure 2. Monthly minimum temperature range

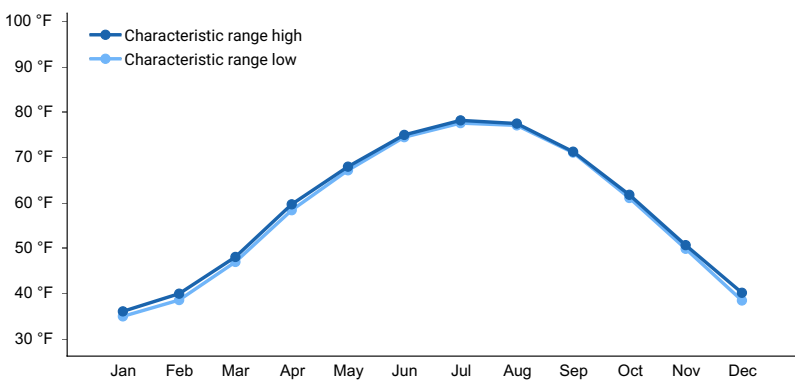

Figure 3. Monthly maximum temperature range

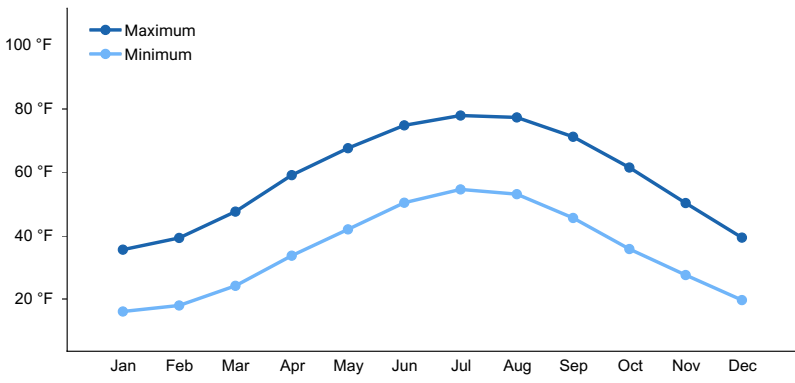

Figure 4. Monthly average minimum and maximum temperature

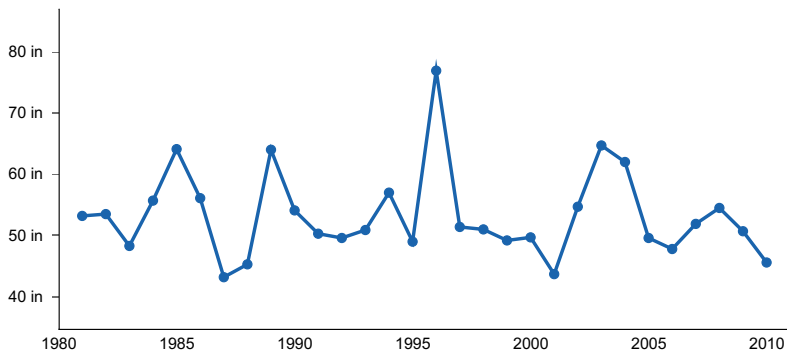

Figure 5. Annual precipitation pattern

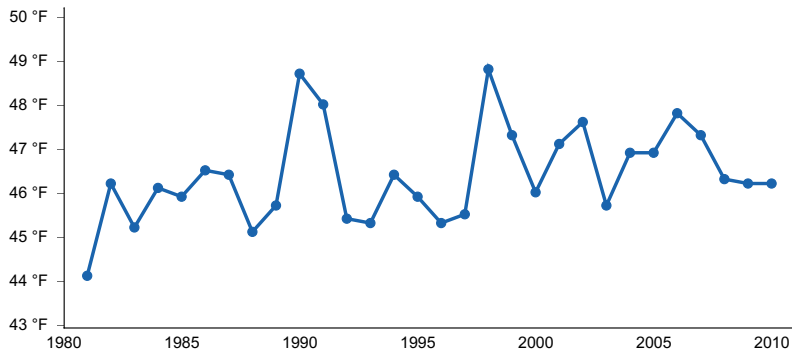

Figure 6. Annual average temperature pattern

Climate stations used

- (1) GLADY 1 N [USC00463464], Glady, WV
- (2) CANAAN VALLEY [USC00461393], Davis, WV

Influencing water features

There are no water features associated with this ecological site.

Soil features

Spodosols characterize the Rubbly Upland Conifer Forest, with podzolization acting as the dominant soil-forming process of the site. High precipitation and cool temperatures accompanied by large quantities of organic acids secreted from roots enable the podzolization process to proceed. Spodic properties develop as organic acids secreted from conifer/ericaceous roots and decomposing needle litter leach through the upper soil horizons, forming organo-metallic complexes with aluminum and iron that are deposited in the deeper mineral soil. Thick O horizons on the forest floor are common, with folistic epipedons being an indicator for the reference state community. Often soils exhibit strong E horizon formation as aluminum and iron are complexed and removed from the upper mineral horizons. Soils vary in rock fragment volume and are accompanied by rubbly or very rubbly surfaces. Representative soils for this ecological site include rubbly and very rubbly phases of the Gauley, Blandburg, Gaudineer, and Leetonia series.

Similarly to the Spodic Shale Upland Conifer Forest and Spodic Intergrade Shale Upland Hardwood and Conifer Forest ecological sites, widespread logging and slash fires of the late-19th and early-20th centuries severely disturbed these landscapes. Removal of red spruce and other podzolizing species by logging and fires accompanied by hardwood species regeneration in absence of conifers likely reduced post-harvest podzolization until conifer species re-established themselves. Relict Spodosols can be found in hardwood dominated community phases where once stood red spruce and eastern hemlock dominated stands. Loss of spodic properties from the soil in the time period succeeding intensive logging is likely but varies spatially.

Table 4. Representative soil features

Parent material	(1) Residuum–sandstone (2) Colluvium–interbedded sedimentary rock
Surface texture	(1) Channery, stony, extremely stony loam
Drainage class	Well drained to somewhat excessively drained
Permeability class	Slow to moderate
Depth to restrictive layer	27–37 in
Soil depth	27–37 in
Surface fragment cover <=3"	0%
Surface fragment cover >3"	13–70%

Available water capacity (Depth not specified)	1–4 in
Soil reaction (1:1 water) (Depth not specified)	2.8–5.5
Subsurface fragment volume <=3" (Depth not specified)	12–30%
Subsurface fragment volume >3" (Depth not specified)	17–99%

Ecological dynamics

Ecological Dynamics: Information contained in this section was adapted from several sources. The information presented is representative of very complex vegetation communities. Key indicator plants, animals and ecological processes are described to

help inform land management decisions. Plant communities will differ across the MLRA because of the naturally occurring variability in weather, soils, and aspect. The reference plant community is not necessarily the management goal. The species lists are representative and are not botanical descriptions of all species occurring, or potentially occurring, on this site. They are not intended to cover every situation or the full range of conditions, species, and responses for the site.

From Landfire <http://www.landfire.gov/index.php>:

This system is naturally dominated by stable, uneven-aged forests, with canopy dynamics dominated by gap-phase regeneration on a fine scale, as well as larger disturbances resulting primarily from ice storms (Nicholas and Zedaker 1989). Despite the extreme climate, *Picea rubens* is long-lived (300-400 or more years) (White et al. 1993). *Picea* seedlings are shade-tolerant, and advanced regeneration is important in stand dynamics. Natural disturbances are primarily wind and ice storms, but may include debris avalanches or extremely rarely lightning fires (White 1984b, Nicholas and Zedaker 1989, White et al. 1993). Climate changes may severely affect this system. Global warming can be expected to raise the lower elevational limit and greatly reduce the land area available to this system.

State and transition model

Ecosystem states

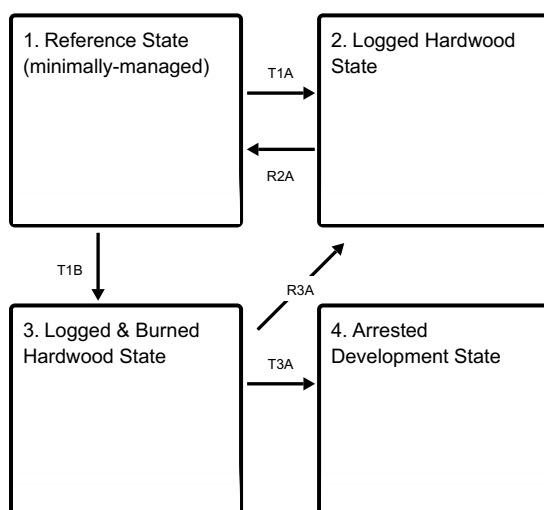

States 1 and 5 (additional transitions)

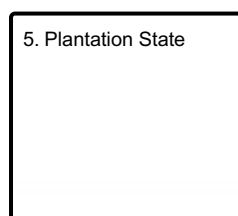
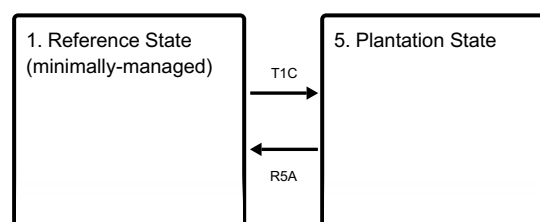

State 1 submodel, plant communities



State 2 submodel, plant communities

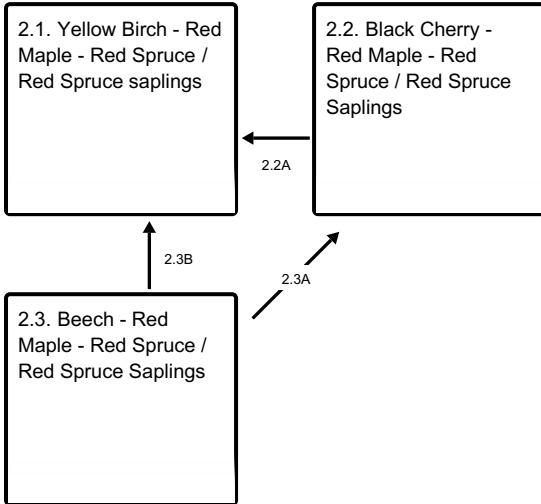

2.2A - Cutting, ringing, or herbicide application to thin hardwood species

State 3 submodel, plant communities

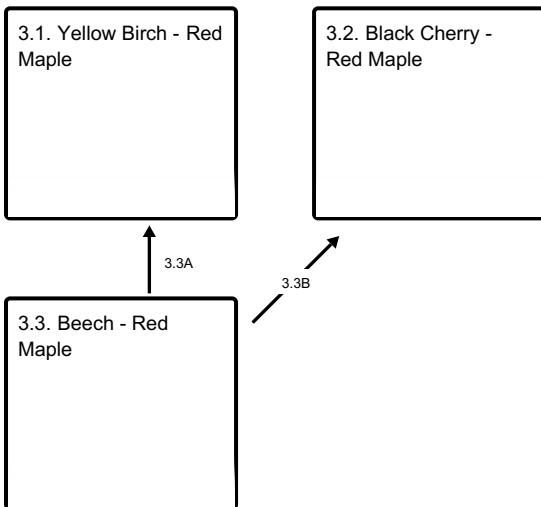

State 4 submodel, plant communities

4.1. Arrested Forest

4.2. Arrested Shrub

4.3. Arrested Fields

State 5 submodel, plant communities

5.1. Red Pine - White
Pine - Norway Spruce -
Red Spruce

State 1

Reference State (minimally-managed)

The reference state condition is characterized by red spruce (30% or more) and yellow birch as dominant components of the overstory canopy. Three-lobed bazzania is common on the forest floor of the reference state (20% or more), and is often accompanied by thick foliastic epipedons. Reference state conditions or near-reference state conditions may provide quality habitat for the endangered Cheat Mountain salamander.

Characteristics and indicators. - 30% or more red spruce in the overstory canopy - 20% or more bazzania ground cover - Folistic epipedons

Dominant plant species

- red spruce (*Picea rubens*), tree
- yellow birch (*Betula alleghaniensis*), tree
- eastern hemlock (*Tsuga canadensis*), tree
- (*Bazzania trilobata*), other herbaceous

Community 1.1

Red Spruce - Yellow Birch / Bazzania

State 2

Logged Hardwood State

The Logged Hardwood State is characterized by a mix of dominant hardwood species including yellow birch, black cherry, red maple and to a lesser extent American beech. Red spruce may be a component of the overstory to varying degrees, but is always less than 30% canopy cover. Absence of fires or occurrence of light fires did not eliminate the red spruce seedbank, allowing for red spruce sapling regeneration in the understory.

Characteristics and indicators. - Less than 30% red spruce in overstory canopy - Red spruce sapling regeneration is present in understory - O horizons are retained to some degree

Dominant plant species

- yellow birch (*Betula alleghaniensis*), tree
- red maple (*Acer rubrum*), tree
- black cherry (*Prunus serotina*), tree
- eastern hemlock (*Tsuga canadensis*), tree
- red spruce (*Picea rubens*), tree
- American beech (*Fagus grandifolia*), tree

Community 2.1

Yellow Birch - Red Maple - Red Spruce / Red Spruce saplings

The yellow birch phase of the Logged Hardwood State is dominated by yellow birch and red maple. Other hardwood species occur at a lesser ratio than yellow birch. Red spruce occurs at varying degrees in the overstory, but always is less than 30% canopy cover. Red spruce regeneration in the understory is prominent to sparse. This is the phase through which restoration into the Reference State may proceed. Beech regeneration in the understory is common.

Dominant plant species

- yellow birch (*Betula alleghaniensis*), tree
- red maple (*Acer rubrum*), tree
- red spruce (*Picea rubens*), tree

Community 2.2

Black Cherry - Red Maple - Red Spruce / Red Spruce Saplings

The black cherry phase of the Logged Hardwood State is dominated by black cherry and red maple. Other hardwood species occur at a lesser ratio than black cherry. Red spruce occurs at varying degrees in the overstory, but is always less than 30% canopy cover. Red spruce regeneration in the understory is prominent to sparse. Often this phase is in transition from the beech phase due to severe and persistent beech bark disease that kills overstory and mid-story beech trees. Beech regeneration in the understory is common.

Dominant plant species

- black cherry (*Prunus serotina*), tree
- red maple (*Acer rubrum*), tree
- red spruce (*Picea rubens*), tree

Community 2.3

Beech - Red Maple - Red Spruce / Red Spruce Saplings

Mature and healthy American beech are indicators for this phase. Beech and red maple are co-dominant, and often exist alongside other hardwood species. Red spruce occurs at varying degrees in the overstory, but is always less than 30%. Red spruce regeneration in the understory is prominent to sparse. Pure beech dominated stands are exceedingly rare but do exist, but is most often in a co-dominant canopy status. This phase is often in transition towards other state phases due to disease. Healthy and mature beech stands are not as common as in the past since the introduction of beech bark disease to North America in the late 19th century. Beech bark disease kills mature/maturing overstory and mid-story beech trees slowly over the course of multiple years. Sustained infection kills off beech and creates canopy gaps whereby transition to other state phases progress. Beech regeneration in the understory is common, often times at a high density.

Dominant plant species

- American beech (*Fagus grandifolia*), tree
- red maple (*Acer rubrum*), tree
- red spruce (*Picea rubens*), tree

Pathway 2.2A

Community 2.2 to 2.1

Selective thinning of hardwood species to create canopy gaps for yellow birch and red spruce regeneration into the mid-story and overstory canopy. This community pathway should be encouraged in preparation for the future return to reference state conditions. Hardwood thinning is conducted through cutting, ringing, or herbicide application to release red spruce and yellow birch.

Pathway 2.3B **Community 2.3 to 2.1**

Beech bark disease kills mature/maturing overstory and mid-story beech trees slowly over the course of multiple years. Sustained infection kills off beech and creates canopy gaps whereby transition to other state phases progress, dependent on the composition of the immediate community. Hardwood thinning is conducted through cutting, ringing, or herbicide application to release red spruce and yellow birch.

Pathway 2.3A **Community 2.3 to 2.2**

Beech bark disease kills mature/maturing overstory and mid-story beech trees slowly over the course of multiple years. Sustained infection kills off beech and creates canopy gaps whereby transition to other state phases progress, dependent on the composition of the immediate community. Hardwood thinning is conducted through cutting, ringing, or herbicide application to release red spruce and black cherry.

State 3 **Logged & Burned Hardwood State**

The Logged & Burned Hardwood State is characterized by a mix of dominant hardwood species including yellow birch, black cherry, red maple and to a lesser extent American beech. Severe fires eliminated the red spruce seedbank whereby red spruce regeneration is absent from the understory. Red spruce is non-dominant in the overstory canopy of this state or completely absent.

Characteristics and indicators. - Absence of red spruce regeneration in understory - Thin O horizons are common and to a lesser extent entirely absent where fires were most severe - Exposed rubbly surface fragments

Dominant plant species

- red maple (*Acer rubrum*), tree
- yellow birch (*Betula alleghaniensis*), tree
- black cherry (*Prunus serotina*), tree
- American beech (*Fagus grandifolia*), tree

Community 3.1 **Yellow Birch - Red Maple**

The yellow birch phase of the Logged and Burned Hardwood State is dominated by yellow birch and red maple. Other hardwood species occur at a lesser ratio than yellow birch. Red spruce generally does not occur in the overstory, while regeneration in the understory is entirely absent. This ecological phase will transition to the yellow birch phase of the Logged Hardwood State with restoration.

Community 3.2 **Black Cherry - Red Maple**

The black cherry phase of the Logged and Burned Hardwood State is dominated by black cherry and red maple. Other hardwood species beside red maple generally occur at a lesser rate than black cherry. Red spruce generally does not occur in the overstory, while regeneration in the understory is entirely absent. Often this phase is in transition from the beech phase due to severe and persistent beech bark disease that kills overstory and mid-story beech trees. Beech regeneration in the understory is commonly seen. This ecological phase will transition to the black cherry phase of the Logged Hardwood State with restoration.

Community 3.3

Beech - Red Maple

Mature and healthy American beech are indicators for this phase. Beech and red maple are co-dominant, and often exist alongside other hardwood species. Red spruce generally does not occur in the overstory, and in the understory red spruce regeneration is absent. Pure beech dominated stands are rare but do exist. This phase is often in transition towards other state phases due to disease. Healthy and mature beech stands are not as common as in the past since the introduction of beech bark disease to North America in the late 19th century. Beech bark disease kills mature/maturing overstory and mid-story beech trees slowly over the course of multiple years. Sustained infection kills off beech and creates canopy gaps whereby transition to other state phases progress. This ecological phase will transition to the beech phase of the Logged Hardwood State with restoration.

Pathway 3.3A

Community 3.3 to 3.1

Beech bark disease kills mature/maturing overstory and mid-story beech trees slowly over the course of multiple years. Sustained infection kills off beech and creates canopy gaps whereby transition to other state phases progress, dependent on the composition of the immediate community.

Pathway 3.3B

Community 3.3 to 3.2

Beech bark disease kills mature/maturing overstory and mid-story beech trees slowly over the course of multiple years. Sustained infection kills off beech and creates canopy gaps whereby transition to other state phases progress, dependent on the composition of the immediate community.

State 4

Arrested Development State

The Arrested Development State composes landscapes that were logged and burned extensively, representing some of the most disturbed ecosystems of this ecological site. This state contains areas of arrested forest, shrub, and mix-species fields, developed where disturbance was most severe. In some areas the overstory species are stunted in growth. Other areas exist dominantly as scrub/shrub barrens, grading into a structure similar to that of a woodland. Further, some areas in this state consist of rubbly outcrops with high areal cover of mixed grass species. The nonvascular stratum has significant diversity, much of which occurs as abundant crustose lichens on the rocky substrate. In some areas this community was probably maintained by fire (for blueberry production) in the period following European settlement. Native Americans may also have practiced burning in this community. Soils are slowly accumulating surface organic matter again in the absence of widespread fires, and in some areas this community is following a very slow successional pathway back to red spruce-yellow birch dominated forest. In some areas, shallow, infertile, and sometimes waterlogged soils and bedrock outcrops appear to maintain community phases within the ecological state. Other areas of the ecological state contain thicker O horizon accumulations, sometimes classifying as a folistic epipedon. This ecological state is culturally significant in that much of these areas are used for outdoor recreational activities and attract significant attention. Restoration of this state might occur over the course of multiple centuries if initiated and maintained.

Characteristics and indicators. - Presence of tree species repressed in growth - Dominant presence of shrub species - Exposed rubbly surface fragments - High areal cover of mixed grass species

Dominant plant species

- red maple (*Acer rubrum*), tree
- yellow birch (*Betula alleghaniensis*), tree
- red spruce (*Picea rubens*), tree
- eastern hemlock (*Tsuga canadensis*), tree
- Allegheny serviceberry (*Amelanchier laevis*), tree
- mountain holly (*Ilex montana*), shrub
- lowbush blueberry (*Vaccinium angustifolium*), shrub
- mountain laurel (*Kalmia latifolia*), shrub

- southern mountain cranberry (*Vaccinium erythrocarpum*), shrub
- Cascade azalea (*Rhododendron albiflorum*), shrub
- great laurel (*Rhododendron maximum*), shrub
- early azalea (*Rhododendron prinophyllum*), shrub

Community 4.1 Arrested Forest

The Arrested Forest community phase contains forest overstory species that exist dominantly at the mid-story canopy level. Canopy is often dominated by red spruce, with a lower cover of red maple, yellow birch, eastern hemlock, and Allegheny serviceberry. Sometimes this community phase does not exist as a closed canopy system.

Dominant plant species

- red spruce (*Picea rubens*), tree
- yellow birch (*Betula alleghaniensis*), tree
- red maple (*Acer rubrum*), tree
- eastern hemlock (*Tsuga canadensis*), tree
- Allegheny serviceberry (*Amelanchier laevis*), tree

Community 4.2 Arrested Shrub

The Arrested Shrub community phase is dominated by a mix of shrub species, often times with regenerating red spruce and other hardwood species co-occurring. The shrub strata are diverse with abundant mountain laurel accompanied by lowbush blueberry, mountain holly, great laurel, minniebush, black huckleberry, black chokeberry, southern mountain cranberry, and other shrubs. Mid-story canopy sized red spruce and other hardwood species may occur scattered through this community type.

Dominant plant species

- red spruce (*Picea rubens*), tree
- yellow birch (*Betula alleghaniensis*), tree
- red maple (*Acer rubrum*), tree
- lowbush blueberry (*Vaccinium angustifolium*), shrub
- southern mountain cranberry (*Vaccinium erythrocarpum*), shrub
- mountain holly (*Ilex montana*), shrub
- minniebush (*Menziesia pilosa*), shrub
- great laurel (*Rhododendron maximum*), shrub
- black huckleberry (*Gaylussacia baccata*), shrub

Community 4.3 Arrested Fields

The Arrested Fields community phase is characterized by rocky, rubbly surfaces that are high in areal cover of mixed species grasses.

State 5 Plantation State

The plantation state is an anthropogenic state created by extensive logging with or without fires and is accompanied by high density plantings of conifer species, most often white pine, red pine, Norway spruce, and red spruce.

Characteristics and indicators. Overstory canopy cover of single species even-aged conifer stands planted in recognizable rows and/or columns.

Community 5.1 Red Pine - White Pine - Norway Spruce - Red Spruce

Dominant plant species

- red pine (*Pinus resinosa*), tree
- eastern white pine (*Pinus strobus*), tree
- red spruce (*Picea rubens*), tree
- Norway spruce (*Picea abies*), tree

Transition T1A

State 1 to 2

Logging with the absence of fire or with the occurrence of light fire removes red spruce from the overstory. Succession gives way to native hardwoods dominating this ecological state, with red spruce retained as a minor component of the overstory community. Fires did not eliminate the red spruce seedbank completely, allowing further red spruce regeneration in the understory.

Transition T1B

State 1 to 3

Logging accompanied by severe fires remove red spruce from the overstory. Succession gives way to native hardwoods. Intense fires burned the red spruce seedbank completely. Red spruce may be absent in the overstory and does not regenerate in the understory due to lack of seed source.

Transition T1C

State 1 to 5

This transition is set in motion by logging, intense fire, and commercial tree planting. Some sites reflect planting of abandoned marginal farmland.

Restoration pathway R2A

State 2 to 1

Restoration involves creating canopy gaps for spruce release through thinning hardwood overstory species using ringing, cutting or herbicide application. Canopy gaps release red spruce from the under-story and mid-story, allowing more red spruce to reach the overstory canopy. Underplanting red spruce depending on levels of regeneration on site may or may not be required.

Restoration pathway R3A

State 3 to 2

Restoration involves creating canopy gaps for spruce release through thinning hardwood overstory species using ringing, cutting or herbicide application. Canopy gaps allow for the release of red spruce from the understory. Underplanting red spruce is required.

Transition T3A

State 3 to 4

Sustained severe fires and prolonged management leads to complete removal of historic ecosystem and seedbanks after logging. Grass fields, shrub/scrub, and arrested forests are all initiated by this disturbance.

Restoration pathway R5A

State 5 to 1

Variable density thinning (cutting, ringing and/or herbicide application) to create structural diversity and release understory and mid-story spruce. Underplanting red spruce when sapling regeneration is absent.

Additional community tables

Animal community

The Cheat Mountain salamander (*Plethodon nettingi*) (CMS) is found in disjunct populations across Cheat Mountain of the Allegheny Mountains as well as other areas encompassing the ecological site. Reference state conditions or near reference state conditions provide quality habitat. CMS relies heavily on interstitial spaces between rock fragments and surface rubble filled with moist organic matter deposits for cover. The CMS is currently classified federally as a threatened species.

The Northern flying squirrel (*Glaucomys sabrinus*) (NFS) is found throughout red spruce landscapes of the Central Appalachians and elsewhere. The NFS relies on hypogeal fungi as a main source of food, which studies have correlated to red spruce presence. Often, ecological restoration aims to increase red spruce cover to 30% or more in the canopy as a means to provide the NFS with beneficial canopy structure, food source, and habitat. The NFS was recently delisted from the federally threatened species list, although conservation efforts still focus on improving red spruce habitat for the species and remains a focal species of importance.

Recreational uses

Recreational activities occurring within the ecological site generally include hiking, camping, fishing, hunting, foraging, boating, and other outdoor related activities.

Inventory data references

Site Development and Testing Plan

Future work is needed, as described in a future project plan, to validate the information presented in this provisional ecological site description. Future work includes field sampling, data collection and analysis by qualified vegetation ecologists and soil scientists. As warranted, annual reviews of the project plan can be conducted by the Ecological Site Technical Team. A final field review, peer review, quality control, and quality assurance reviews of the ESD are necessary to approve a final document.

Other references

Landfire <http://www.landfire.gov/index.php>

Braun, E.L. 1950. Deciduous forests of eastern North America. Hafner Publishing Company, New York, NY. 596 pp.

Cutter, B.E. and R.P. Guyette. 1994. Fire history of an oak-hickory ridge top in the Missouri Ozarks. *American Midland Naturalist* 132: 393-398.

Greller, A. M. 1988. Deciduous forest. In: M.G. Barbour and W. D. Billings, eds. *North American terrestrial vegetation*. Cambridge University Press, NY. 287-326.

Landfire 2009. Descriptions of Ecological Systems for the Modeling of Landfire BioPhysical Settings. (unpubl. manuscript)

NatureServe. 2007. International Ecological classification Standard: Terrestrial Ecological Classifications. NatureServe Central Databases. Arlington, VA, USA. Data current as of 08 June 2007.

Schuler, T.M. and W.R. McClain. 2003. Fire history of a ridge and valley oak forest. Newtown Square, PA. USDA Forest Service, Northeastern Forest Service.

Approval

Nels Barrett, 6/06/2022

Rangeland health reference sheet

Interpreting Indicators of Rangeland Health is a qualitative assessment protocol used to determine ecosystem

condition based on benchmark characteristics described in the Reference Sheet. A suite of 17 (or more) indicators are typically considered in an assessment. The ecological site(s) representative of an assessment location must be known prior to applying the protocol and must be verified based on soils and climate. Current plant community cannot be used to identify the ecological site.

Author(s)/participant(s)	
Contact for lead author	
Date	06/04/2023
Approved by	Nels Barrett
Approval date	
Composition (Indicators 10 and 12) based on	Annual Production

Indicators

1. **Number and extent of rills:**

2. **Presence of water flow patterns:**

3. **Number and height of erosional pedestals or terracettes:**

4. **Bare ground from Ecological Site Description or other studies (rock, litter, lichen, moss, plant canopy are not bare ground):**

5. **Number of gullies and erosion associated with gullies:**

6. **Extent of wind scoured, blowouts and/or depositional areas:**

7. **Amount of litter movement (describe size and distance expected to travel):**

8. **Soil surface (top few mm) resistance to erosion (stability values are averages - most sites will show a range of values):**

9. **Soil surface structure and SOM content (include type of structure and A-horizon color and thickness):**

10. **Effect of community phase composition (relative proportion of different functional groups) and spatial distribution on infiltration and runoff:**

11. **Presence and thickness of compaction layer (usually none; describe soil profile features which may be mistaken for compaction on this site):**

12. **Functional/Structural Groups (list in order of descending dominance by above-ground annual-production or live foliar cover using symbols: >>, >, = to indicate much greater than, greater than, and equal to):**

Dominant:

Sub-dominant:

Other:

Additional:

13. **Amount of plant mortality and decadence (include which functional groups are expected to show mortality or decadence):**

14. **Average percent litter cover (%) and depth (in):**

15. **Expected annual annual-production (this is TOTAL above-ground annual-production, not just forage annual-production):**

16. **Potential invasive (including noxious) species (native and non-native). List species which BOTH characterize degraded states and have the potential to become a dominant or co-dominant species on the ecological site if their future establishment and growth is not actively controlled by management interventions. Species that become dominant for only one to several years (e.g., short-term response to drought or wildfire) are not invasive plants. Note that unlike other indicators, we are describing what is NOT expected in the reference state for the ecological site:**

17. **Perennial plant reproductive capability:**
