

Ecological site F134XY102MS

Southern Rolling Plains Loess Stream Terrace - PROVISIONAL

Accessed: 12/08/2023

General information

Provisional. A provisional ecological site description has undergone quality control and quality assurance review. It contains a working state and transition model and enough information to identify the ecological site.



Figure 1. Mapped extent

Areas shown in blue indicate the maximum mapped extent of this ecological site. Other ecological sites likely occur within the highlighted areas. It is also possible for this ecological site to occur outside of highlighted areas if detailed soil survey has not been completed or recently updated.

MLRA notes

Major Land Resource Area (MLRA): 134X–Southern Mississippi Valley Loess

MLRA 134, Southern Mississippi Valley Loess, is in Mississippi (39 percent), Tennessee (23 percent), Louisiana (15 percent), Arkansas (11 percent), Kentucky (9 percent), Missouri (2 percent), and Illinois (1 percent). It makes up about 26,520 square miles (68,715 square kilometers). The northern part of the area includes Paducah and Murray, Kentucky; Paragould, Jonesboro, and Forrest City, Arkansas; and Memphis, Dyersburg, Bartlett, and Germantown, Tennessee. The southern part includes Yazoo City, Clinton, and Jackson, Mississippi, and Baton Rouge, Opelousas, Lafayette, and New Iberia, Louisiana. This portion is the farthest southeast part of the MLRA in Louisiana. It is in the Mississippi Valley Loess Plains Section of the EPA Ecoregions in sub-section 74c, Southern rolling Plains. The dissected plains in this MLRA have a loess mantle that is thick at the valley wall and thins rapidly as distance from the valley wall increases. Although less dissected than the Bluff Hills (74a), the region has more irregular and dissected topography than adjacent 74b to the north in Mississippi. The historic forests contained shortleaf pine, loblolly pine, and upland oaks and hickories. Pine is naturally more prevalent here than in 74a and 74b. Land cover now is mostly mixed pine-hardwood forest, pine plantations, pasture, and cropland. The eastern boundary of this region is broad, with a gradual transition to the southern Coastal Plains.

Classification relationships

Major Land Resource Area (MLRA) and Land Resource Unit (LRU) (USDA-Natural Resources Conservation Service, 2006)

Ecological site concept

Deep to very Deep, Moderately Well to Excessively drained, nearly level soils on flood plains and low stream terraces; these sites are subject to rare to frequent flooding. Nearly linear surfaces of higher parts of flood plains or low stream terraces. These soils formed in silty or loamy alluvial sediment along streams that drain areas of the Southern Mississippi Valley Loess Major Land Resource Area in level IV EPA Ecoregion 74c, Southern Rolling Plains of the Southern Mississippi Valley Loess Plains.

Associated sites

F134XY101MS	Southern Rolling Plains Loess Drainways - PROVISIONAL 134XY101 Southern Rolling Plains Loess Drainways will be found at elevation below this site with a greater flooding frequency.
-------------	--

Similar sites

F134XY122LA	Baton Rouge Terrace Southern Loess Stream Terrace - PROVISIONAL 134XY122 Baton Rouge Terrace Southern Loess Stream Terrace fits a similar site position on the landscape, however is found in the Baton Rouge Terrace Portion of the MLRA to the south of this site.
-------------	--

Table 1. Dominant plant species

Tree	Not specified
Shrub	Not specified
Herbaceous	Not specified

Physiographic features

The Bluff Hills and the Southern Rolling Plains (EPA Level IV Ecoregions 74A and 74C, respectively) of the Southern Mississippi Valley Loess (MLRA 134) are located in southwest Mississippi and southeast Louisiana. The areas lie within the Coastal Plain Province of the Atlantic Plain. The underlying geology consists of marine deposits of sand, silt, clay, and lignite of the Pascagoula, Hattiesburg, Catahoula and Citronelle formations. The Bluff Hills, which bound the Mississippi River floodplain, are capped by loess deposits often greater than 50 feet thick (Chapman et al., 2004). The adjacent terraces of the Southern Rolling Plain are loess mantled as well.

“Loess” is the geologic term of German origin that refers to widespread deposits of homogeneous layers of friable, porous silt mixed with minor amounts of clay or fine sand (Heinrich, 2008). The loess mantle, created by well-sorted windblown silt, was deposited during the Pleistocene age. Its source was glacial sediment from glacial meltwater that was flowing down an extensive braided stream system depositing large volumes of silt over the floodplain of the Mississippi River (Heinrich, 2008). Glacial meltwater ceased flowing when southern edges of ice sheets stopped melting in fall and winter, thereby creating dry conditions on the previously flooded Mississippi River Valley. Strong seasonal winds blew across dry floodplains and eroded large quantities of silt-sized sediment, and transported it out of the Mississippi alluvial valley and deposited it on adjacent uplands and terraces (Heinrich, 2008). Over thousands of years, the silt accumulations created loess deposits that are many feet thick (Heinrich, 2008). The Bluff Hills and Southern Rolling Plains are covered mainly with 2 separate layers (and ages) of loess deposits, the older and lower Sicily Island loess and the younger Peoria loess at the soil surface.

Where blankets of loess are thicker than 6 feet, the soils formed entirely in loess. Where loess deposits are less than 6 feet thick, soils reflect the nature of the underlying parent material (McDaniel, 2001). Thick loess areas produce intensely dissected terrain with excessively steep slopes and ridge and ravine topography (McDaniel, 2001). The Bluff Hills tend to have deeper, calcareous loess and steeper, much more dissected topography than the Southern Rolling Plains to the east. The loess mantle on the Southern Rolling Plains begins to thin and become more acid in the east as it transitions to the Southeastern Plains. Stream gradients in the Bluff Hills are high with

narrow drainageways and floodplains, while the stream gradients become lower with broader floodplains in the Southern Rolling Plains.

This Site occurs mainly on the higher elevations of broad floodplains and low stream terraces of large creeks and rivers and their tributaries draining the Southern Rolling Plains and flowing through the Bluff Hills in Mississippi and Louisiana. Smaller areas of this site occur on the alluvial fans/aprons at the base of the loessal bluffs that border the Mississippi River floodplain. Slopes are level to nearly level (0 to 3 percent). These sites include the floodplains and drainageways of the Second Creek, the Homochitto River and its tributaries, such as Sandy Creek and East Field Creek; the Big Black River, Bayou Pierre and its tributaries, such as Little Bayou Pierre, White Oak Creek; Foster Creek, Bahala Creek, the North Fork and South Fork of Coles Creek, McCall Creek, McGehee Creek; the Bogue Chitto, Buffalo River; the Pearl river, the Amite River and its tributaries; and the West Fork of Little Comite Creek.

Table 2. Representative physiographic features

Landforms	(1) Flood plain (2) Stream terrace (3) Alluvial fan
Flooding duration	Brief (2 to 7 days) to long (7 to 30 days)
Flooding frequency	Occasional to frequent
Ponding frequency	None
Elevation	45–440 ft
Slope	0–3%
Water table depth	24–72 in
Aspect	Aspect is not a significant factor

Climatic features

The Southern Rolling Plains portions of MLRA 134 in Mississippi and Louisiana has a warm, humid climate, with fairly long summers and relatively short winters. The result is a long growing season and abundant plant growth. As you move northward in this region temperature trends lower and Precipitation is not as well distributed. This change in distribution does not imply that there is a rainy season and dry season, however there is a change in distribution. Water is a definitive part of this landscape, largely due to the combination of low elevation and fairly abundant rainfall in most years. Mean annual precipitation ranges from 50 to 70 inches over this region, and is fairly well distributed throughout the year. There have been very few years when less than 50 inches of precipitation has fallen. Snow is a rarity, however chances increase as you move Northward through the region. Growing seasons are long, typically from late February to late November. Hurricanes and tropical storms impact the climate of this region predominately in the southern areas, with some impact occurring nearly every year in some areas. However, devastating storms do not occur too often, and heavy rain is usually the biggest concern compared to wind damage. The following climatic data are averages from the ten weather stations listed below. Temperature and precipitation may vary considerably from that listed for each month. Site specific weather data should be used for land management decisions. For site specific weather conditions, obtain data from a weather station close to the site. Information can be accessed from specific weather stations at <http://www.wrcc.dri.edu/coopmap/> or <http://www.wrcc.dri.edu/summary/climsmla.html>.

Table 3. Representative climatic features

Frost-free period (average)	227 days
Freeze-free period (average)	268 days
Precipitation total (average)	62 in

Climate stations used

- (1) CLINTON 5 SE [USC00161899], Clinton, LA

- (2) HAZLEHURST 5 SW [USC00223920], Hazlehurst, MS
- (3) WOODVILLE 4 ESE [USC00229793], Centreville, MS
- (4) MCCOMB/PIKE CO/JOHN E LEWIS AP [USW00093919], McComb, MS
- (5) BROOKHAVEN CITY [USC00221094], Brookhaven, MS
- (6) CRYSTAL SPGS EXP STN [USC00222094], Crystal Springs, MS
- (7) OAKLEY EXP STN [USC00226476], Raymond, MS
- (8) NATCHEZ [USC00226177], Natchez, MS
- (9) PORT GIBSON 1 NE [USC00227132], Port Gibson, MS
- (10) MEADVILLE [USC00225704], Bude, MS

Influencing water features

This site is influenced by both surface and sub-surface hydrology as part of the flood plain of Streams and creeks. Soils may be saturated into early spring. Wetness is a dominate driver of this system and in Alternative States it will be a limiting factor.

Soil features

Soils are moderately well drained Fluvaquent Eutrudepts (Adler, Riedtown), moderately well drained Aquic Udifluvents (Collins) moderately well drained Fluvaquent Dystrudepts (Oaklimeter), well drained Fluventic Dystrudepts (Ariel), well drained Dystric Eutrudepts (Weyanoke), well drained Typic Udifluvents (Morganfield, Vicksburg), and well drained Haplic Glossudalfs (Leverett). Soils also include miscellaneous areas of riverwash, sandy and mixed alluvial land. These soils formed in water-reworked loess and loamy to sandy alluvium derived from streams that drain the loess-mantled uplands of the Southern Mississippi Valley Loess (MLRA 134) and Southern Coastal Plain (MLRA 133A) of the late Pleistocene Age. Slopes range from 0 to 3 percent. These deep and very deep, moderately to rapidly permeable soils are found on the higher parts of narrow to broad floodplains, low stream terraces, and on the alluvial fans/aprons at the base of the loessal bluffs that border the Mississippi River floodplain. The water table is within 2 to 6 feet of the surface during winter and spring months in normal years. Most of these soils are subject to occasional to frequent flooding of brief to long duration.

The soils listed in this section of the description may not be all inclusive. There may be other soils that fit this site concept, as well as in some areas where the listed soils are mapped they may not fit the site concept. Some soil map units and soil series included in this Provisional Ecological Site grouping were used as “best fit” for a particular soil-landscape catena during a specific era of soil mapping, regardless of origin of parent material or Major Land Resource Area. Therefore, these soil series may not be typical for MLRA 134, and those soil map units deserve further investigation in a joint ecological-soil survey project. When utilizing this description verify it is the correct site utilizing multiple parameters, the soils, the physiography and the location. If the site does not fit the particular location well utilize the Similar or Associated Sites listed in the Supporting Information section of this description to determine if another site may be a better fit to your location.

Table 4. Representative soil features

Surface texture	(1) Silt loam (2) Silt (3) Sandy loam
Family particle size	(1) Loamy
Drainage class	Moderately well drained to well drained
Permeability class	Moderate to rapid
Soil depth	60–80 in
Surface fragment cover <=3"	0%
Surface fragment cover >3"	0%
Available water capacity (0-40in)	0–0.25 in
Calcium carbonate equivalent (0-40in)	0%

Electrical conductivity (0-40in)	0 mmhos/cm
Sodium adsorption ratio (0-40in)	0
Soil reaction (1:1 water) (0-40in)	4.5–8.4
Subsurface fragment volume <=3" (Depth not specified)	0%
Subsurface fragment volume >3" (Depth not specified)	0%

Ecological dynamics

The pre settlement plant community of this site would have been dominated by bottomland hardwood species. Within this site there will be a gradient of wetness from occasional to frequent flooding. The wetness variations will dictate the species that are present and the composition of them within an area.

Due to wetness, rooting depths of some species will be limited and due to this and there is a potential for some trees to be uprooted by climatic events, such as strong winds or floods. With these events, openings in the canopy can occur which will set back succession and allow herbaceous and woody shrub species to colonize, these low stature communities are generally short lived and the upper canopy will close as tall growing trees mature. There is generally an age gradient within a forest stand from the herbaceous openings to mature bottomland hardwoods.

Another historical ecological process that drove the system was fire, on this site due to wetness the vegetative production would have provided fuel, flooding may have reduced the burn or may have created a mosaic pattern of drier portions burned at a given time. Adjacent drier sites would have carried a fire and would have burned into this site and if conditions were adequate the fire would have burned through this site setting back succession of the herbaceous layer. However Fire intensity could have been reduced due to the wetness in portions of the site. Historically the region experienced a fire return interval of 2 to 4 years, intensity of the fire would have impacted the species composition of the site.

This site has been altered by human activity and is utilized for multiple production systems such as Cropland, Pasture and Tree Farms, for all of these alternative states wetness is a limitation for this site for productivity and management activities. Within the alternative uses of the site the transitions will be very similar and require the input of resources such as installation of infrastructure needs and establishment of the desired species.

State and transition model

STM - 134XY102

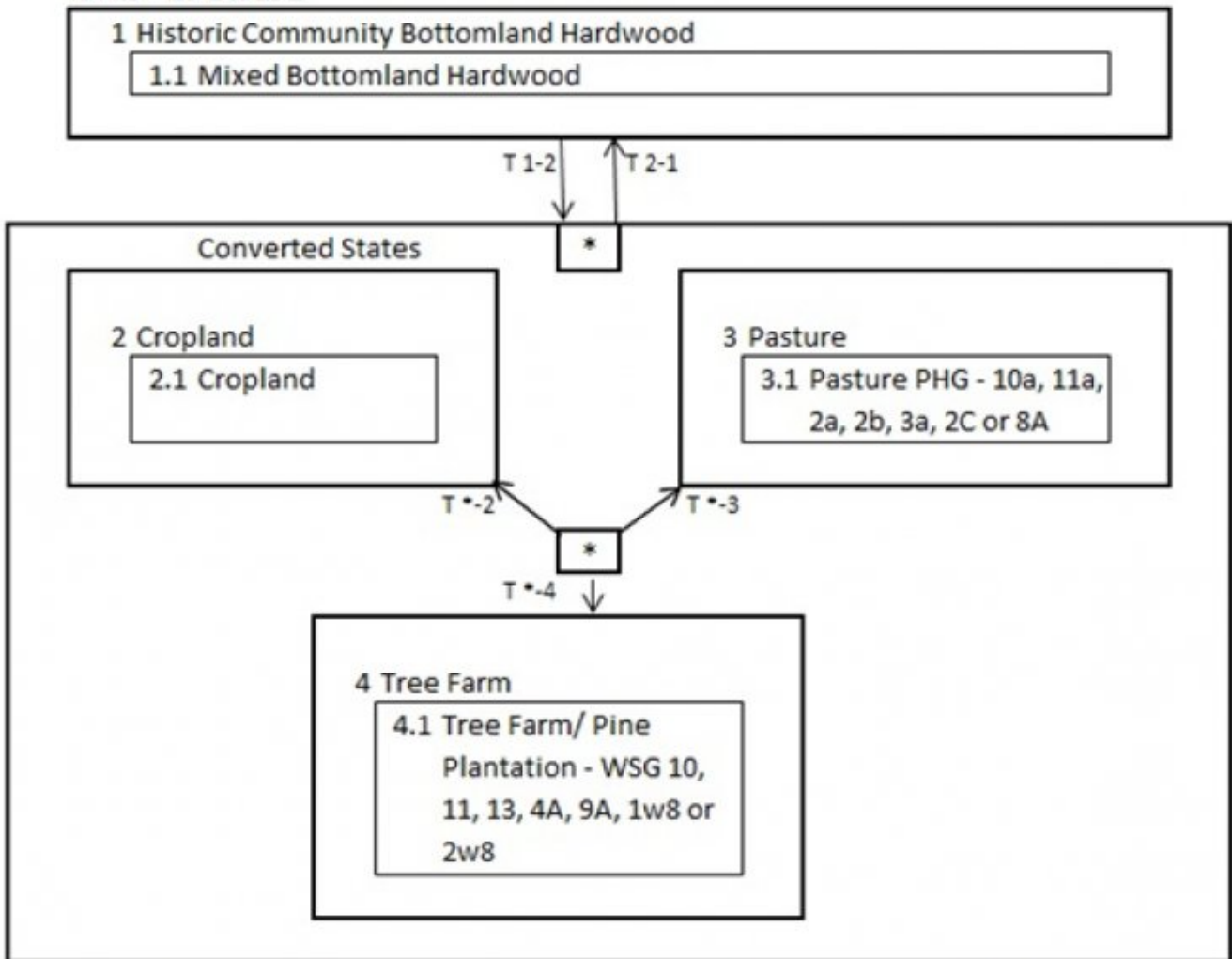

*To reduce clutter and confusion, additional arrowed transitions from and to State 1 are not pictured. Transitions are possible to and from this states as depicted by the transition arrows, consider the starred box every other converted state and transitions will be explained in detail in the appropriate state/community sections.

Diagram Legend

T 1-2	Clear and established the desired Community
T 2-1	Replant to historic community.
T *-2	Establish and manage crop rotation.
T *-3	Establish desired forage species and manage for grazing.
T *-4	Plant or regenerate desired tree species.

Figure 6. 134XY102 Southern Loess Stream Terrace - PES STM

**State 1
Historic Community - Bottomland Hardwoods**

Historically bottomland hardwoods, Cherrybark oak, Eastern Cottonwood, Loblolly Pine, Nuttall oak, Water oak, Sweetgum and Yellow-Poplar

**Community 1.1
Bottomland Hardwood**

Cherrybark oak, Eastern Cottonwood, Loblolly Pine, Nuttall oak, Water oak, Sweetgum and Yellow-Poplar

State 2 Cropland

Cropland

Community 2.1 Cropland

Row Crop Production

State 3 Pastureland

Managed Pasture - PHG 2a, 2b, 3a, 10a, 11a, 2C or 8A.

Community 3.1 Pasture

Pasture or Grassland: This phase is characterized by a monoculture of or mixture of Forage species planted or allowed to establish from naturalized species, managed for forage production or as herbaceous ground cover. This Site fits into multiple Pasture Suitability Groups: 2a, 2b, 3a, 5a, 10a or 11a in MS or 2C or 8A in LA. • 2a - Bottomland, deep, medium textured soils, Well to somewhat poorly drained • 2b - Bottomland, deep, medium textured soils, Well to somewhat poorly drained • 3a - Bottomland, deep, coarse textured soils, Excessively drained • 5a - Bottomland, moderately deep, medium textured soils, Poorly drained • 10a - Upland, moderately deep, fine textured soils, Somewhat poorly and poorly drained • 11a - Upland, moderately deep, medium textured soils, Moderately well and somewhat poorly drained • 2 - Bottomland, deep, medium-textured soil • C – wetness limitations due to high water tables or soil saturation during the growing season which restricts species or yield • 8 - Upland, deep, medium-textured soil • A – soils having few limitations for the growth of the commonly grown plants except for slope From these bullet descriptions of the Groups this site would generally be described as a Moderately Deep to Deep, Excessively to somewhat poorly drained, Medium to fine textured soil on Uplands and alluvial bottoms. It has a range of limiting factors including wetness. All soils need nitrogen fertilization for production when grasses are grown alone. It is not practical to apply high rates of fertilizer due to the wetness limitation potential of the site. To prevent extreme acidity in the subsoil when high rates of acidifying nitrogen is used, the surface soil should not be allowed to become more acid than 5.0 pH and lime should be applied at more frequent intervals.

Table 5. Annual production by plant type

Plant Type	Low (Lb/Acre)	Representative Value (Lb/Acre)	High (Lb/Acre)
Grass/Grasslike	1600	3400	5100
Total	1600	3400	5100

State 4 Tree Farm

Tree Farm

Community 4.1 Tree Farm

Hardwood or Pine Plantation: This phase is characterized by few or a monoculture of Hardwood or Pine species planted or allowed to regenerate from seed trees managed for wood production. This Site fits into multiple Woodland Management and Productivity Groups 10, 11, 13, 4A or 9A in MS. The first element in ordination is a number that denotes potential productivity in terms of cubic meters of wood per hectare per year for an indicator

tree species. The larger the number, the greater the potential productivity. (1 means 1 cubic meter per hectare per year (14.3 cu.ft./ac) 10 means 10 cubic meters per hectare per year (143 cu.ft./ac)) The second element or subclass is indicated by a capital letter, which indicates certain soil or physiographic characteristics that contribute to important hazards or limitations in management. Subclass A - No or slight limitations. OR this Site fits into multiple Woodland Suitability Groups 1w8 or 2w8 in LA, depending on the soil Mapunit. The first part of the symbol indicates potential productivity of the soils for important trees, very high productivity (1) high (2). The second part, a letter, indicates the major kind of soil limitation, limitation of excessive water in or on the soil (w). The third part of the symbol, a numeral, indicates the kind of trees for which the soils are best suited and the severity of the hazard or limitation. The numeral 8 indicate moderate limitations and suitability for both needle leaf and broadleaf trees. WS 1 w 8 Slightly wet soils with very high productivity; moderate equipment limitations and slight to moderate seedling mortality; suitable for either pine or southern hardwoods. Site index for loblolly and slash pine 100, cottonwood 100-110, oaks and sweetgum 100. Potential is high for management of turkey and moderate high for deer, ducks, quail, and squirrels. WS 2 w 8 Slightly to moderately wet, acid, loamy and clayey soils with high potential productivity; moderate equipment limitations due primarily to excess water; well suited for either pines or southern hardwoods. Site index for loblolly and slash pine 90, oaks and sweetgum 90. Potential is high for management of turkey and moderately high for deer, ducks, quail and squirrels. These groups would generally describe this site as moderately to highly productive with moderate limitations for wetness for the production of broadleaf and some needle leaf species.

Additional community tables

Table 6. Community 3.1 plant community composition

Group	Common Name	Symbol	Scientific Name	Annual Production (Lb/Acre)	Foliar Cover (%)
Grass/Grasslike					
1	Warm Season Grasses			1600–5100	
	Bermudagrass	CYDA	<i>Cynodon dactylon</i>	1600–5100	–

Animal community

.

Hydrological functions

.

Recreational uses

.

Wood products

.

Other products

.

Other information

.

Other references

Autin, W. J., Burns, S. F., Miller, B. J., Saucier, R. T., & Snead, J. I. (1991). Quaternary geology of the lower Mississippi Valley. *The Geology of North America*, 2, 547-582.

Chapman, S.S., Griffith, G.E., Omernik, J.M., Comstock, J.A., Beiser, M.C., and Johnson, D., 2004, Ecoregions of Mississippi, (color poster with map, descriptive text, summary tables, and photographs): Reston, Virginia, U.S. Geological Survey (map scale 1:1,000,000).

Cowardin, L. M., Carter, V., Golet, F. C., & LaRoe, E. T. (1979). Classification of wetlands and deepwater habitats of the United States. US Fish and Wildlife Service FWS/OBS, 79(31), 131.

Daigle, J.J., Griffith, G.E., Omernik, J.M., Faulkner, P.L., McCulloh, R.P., Handley, L.R., Smith, L.M., and Chapman, S.S., 2006, Ecoregions of Louisiana (color poster with map, descriptive text, summary tables, and photographs): Reston, Virginia, U.S. Geological Survey (map scale 1:1,000,000).

Emerson, F. V. (1918). Loess-depositing winds in Louisiana. *The Journal of Geology*, 26(6), 532-541.

Ezell, A. W., & Hodges, J. D. (1995). Bottomland hardwood management: Species Site Relationships. MSU Extension Service Publication 2004.

Guyette, R. P., Stambaugh, M. C., Dey, D. C., & Muzika, R. M. (2012). Predicting fire frequency with chemistry and climate. *Ecosystems*, 15(2), 322-335.

Heinrich, P. V., (2008)_Loess Map of LA, Louisiana Geological Survey

Kochian, L. V., Pineros, M. A., & Hoekenga, O. A. (2005). The physiology, genetics and molecular biology of plant aluminum resistance and toxicity. In *Root Physiology: From Gene to Function* (pp. 175-195). Springer Netherlands.

Miller, B. J., Lewis, G. C., Alford, J. J. & Day, W. J. (1984) Loesses in Louisiana and at Vicksburg, Mississippi. Guidebook for Friends of the Pleistocene Field Trip.

Miller, B. J., Day, W. J., & Schumacher, B. A. (1986). Loesses and loess-derived soils in the Lower Mississippi Valley. Guidebook for soils-geomorphology tour.

Pettry, D. E., & Switzer, R. E. (1998). Sodium soils in Mississippi.

Rutledge, E.M., M.J. Guccione, H.W. Markewich, D.A. Wysocki, and L.B. Ward. 1996. Loess stratigraphy of the Lower Mississippi Valley. *Engineering Geology* 45: 167-183.

Saucier, Roger T. 1994. *Geomorphology and Quaternary Geologic History of the Lower Mississippi Valley, Volume II*. U.S. Army Corps of Engineers, Vicksburg, MS.

Schumacher, B. A., Miller, B. J., & Day, W. J. (1987). A chronotoposequence of soils developed in loess in central Louisiana. *Soil Science Society of America Journal*, 51(4), 1005-1010.

Theriot, R. F. (1992). Flood tolerance of plant species in bottomland forests of the southeastern United States.

United States Salinity Laboratory Staff, USA, USDA (1954), *Diagnosis and improvement of saline and alkali soils*, USDA Agriculture Handbook 60,1954, 160 pp.

Contributors

D Charles Stemmans II
Rachel Stout Evans

Rangeland health reference sheet

Interpreting Indicators of Rangeland Health is a qualitative assessment protocol used to determine ecosystem condition based on benchmark characteristics described in the Reference Sheet. A suite of 17 (or more) indicators are typically considered in an assessment. The ecological site(s) representative of an assessment location must be known prior to applying the protocol and must be verified based on soils and climate. Current plant community cannot be used to identify the ecological site.

Author(s)/participant(s)	
Contact for lead author	
Date	
Approved by	
Approval date	
Composition (Indicators 10 and 12) based on	Annual Production

Indicators

1. **Number and extent of rills:**

2. **Presence of water flow patterns:**

3. **Number and height of erosional pedestals or terracettes:**

4. **Bare ground from Ecological Site Description or other studies (rock, litter, lichen, moss, plant canopy are not bare ground):**

5. **Number of gullies and erosion associated with gullies:**

6. **Extent of wind scoured, blowouts and/or depositional areas:**

7. **Amount of litter movement (describe size and distance expected to travel):**

8. **Soil surface (top few mm) resistance to erosion (stability values are averages - most sites will show a range of values):**

9. **Soil surface structure and SOM content (include type of structure and A-horizon color and thickness):**

10. **Effect of community phase composition (relative proportion of different functional groups) and spatial distribution on infiltration and runoff:**

11. **Presence and thickness of compaction layer (usually none; describe soil profile features which may be mistaken for compaction on this site):**

12. **Functional/Structural Groups (list in order of descending dominance by above-ground annual-production or live foliar cover using symbols: >>, >, = to indicate much greater than, greater than, and equal to):**

Dominant:

Sub-dominant:

Other:

Additional:

13. **Amount of plant mortality and decadence (include which functional groups are expected to show mortality or decadence):**
-

14. **Average percent litter cover (%) and depth (in):**
-

15. **Expected annual annual-production (this is TOTAL above-ground annual-production, not just forage annual-production):**
-

16. **Potential invasive (including noxious) species (native and non-native). List species which BOTH characterize degraded states and have the potential to become a dominant or co-dominant species on the ecological site if their future establishment and growth is not actively controlled by management interventions. Species that become dominant for only one to several years (e.g., short-term response to drought or wildfire) are not invasive plants. Note that unlike other indicators, we are describing what is NOT expected in the reference state for the ecological site:**
-

17. **Perennial plant reproductive capability:**
-